

Pei Chun Public School  
Semestral Assessment 1 – 2009  
Mathematics  
Primary 6

**Paper 1 (Booklet A)**

You are **not** allowed to use a calculator.

Name: \_\_\_\_\_ ( )

Date: 14 May 2009

Class: Primary 6 \_\_\_\_\_

Total Time for Booklets A and B: 50 min

Maths Teacher : \_\_\_\_\_

Parent's signature : \_\_\_\_\_

Questions 1 to 10 carry 1 mark each. Questions 11 to 15 carry 2 marks each.  
For each question, four options are given. One of them is the correct answer. Make your choice (1, 2, 3 or 4). Shade the correct oval (1, 2, 3 or 4) on the Optical Answer Sheet.  
( 20 marks )

1. Which of the following would be a possible floor area of a classroom?

(1) 75 km<sup>2</sup>

(2) 75 m<sup>2</sup>

(3) 750 cm<sup>2</sup>

(4) 750 m<sup>2</sup> ( )

2. I am a 2-digit whole number smaller than 60. When divided by 5, I have a remainder of 4. When divided by 6, I have a remainder of 1. When divided by 7, my remainder is 5. What number am I?

(1) 54

(2) 49

(3) 37

(4) 19 ( )

3. Find the value of  $62 - 5 \times (2 + 4) + 3$ .

(1) 17

(2) 29

(3) 35

(4) 345

( )

4. There are 600 workers in a factory. There are 40 more male workers than female workers. How many female workers are there in the factory?

(1) 280

(2) 320

(3) 560

(4) 640

( )

5. Which of the following fractions is less than  $\frac{1}{3}$ ?

(1)  $\frac{6}{19}$

(2)  $\frac{4}{11}$

(3)  $\frac{7}{20}$

(4)  $\frac{10}{29}$

( )

6. The length of a square is an odd number. Which of the following can be the perimeter of the square?

(1) 59 cm

(2) 37 cm

(3) 32 cm

(4) 28 cm

( )

7. The table below shows the times that a train leaves a train station and arrives at the airport.

Leaves train station	Arrives at the airport
8.50 a.m.	9.10 a.m.
9.20 a.m.	9.40 a.m.
10.50 a.m.	11.10 a.m.
11.20 a.m.	11.40 a.m.

Mr Smith wants to take the latest train from the station that will get him to the airport by 11.30 a.m. At what time does this train leave the train station?

- (1) 8.50 a.m.  
 (2) 9.20 a.m.  
 (3) 10.50 a.m.  
 (4) 11.20 a.m. ( )

8. The table below shows the number of pupils from class 6Q scoring within various mark ranges in a Mathematics test. Part of the table was smeared with ink.

Marks	Number of Pupils
91 - 100	5
81 - 90	4
71 - 80	
61 - 70	
51 - 60	

35 pupils scored 61 marks and above. How many pupils scored in the mark range 61 - 80?

- (1) 9  
 (2) 26  
 (3) 30  
 (4) 44 ( )

9. Billy has \$2p. Albert has \$8 more than Billy. Ryan has \$5. How much money do the three boys have altogether?

- (1) \$(2p + 13)  
 (2) \$(4p + 8)  
 (3) \$(4p + 13)  
 (4) \$(10p + 5) ( )

10. This figure shows a pyramid.

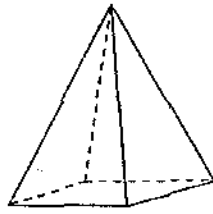

Which one of the following is a net of the solid?

(1)

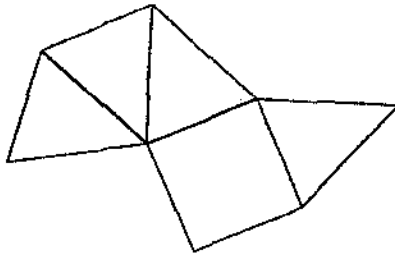

(2)

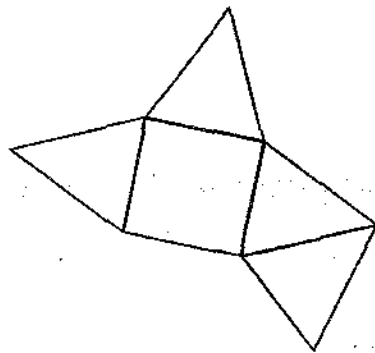

(3)

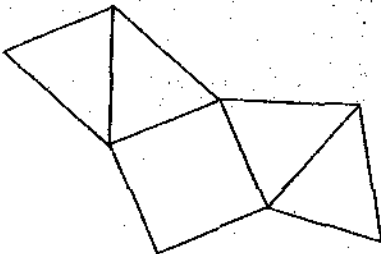

(4)

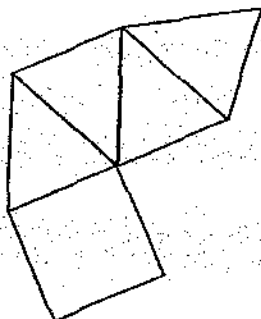

( )

11. Study the pattern below. A, B and C are different whole numbers.

10 , 11 , 15 , 24 , A , B , C

What is the number in box C?

- (1) 49
- (2) 101
- (3) 106
- (4) 150

( )

12. In the figure below, four identical unshaded triangles and a square R lie within a large square ABCD. The area of R is twice the area of an unshaded triangle.

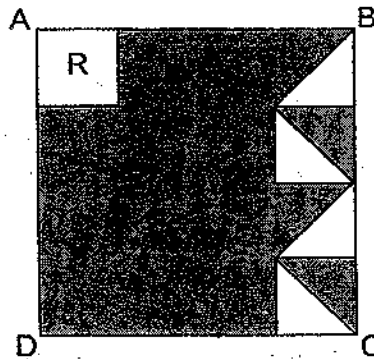

What fraction of the square ABCD is shaded?

- (1)  $\frac{3}{16}$
- (2)  $\frac{1}{6}$
- (3)  $\frac{13}{16}$
- (4)  $\frac{5}{6}$

( )

13. Samuel had a box of pens. 20% of them were red pens and the rest were green pens. He gave away  $\frac{1}{5}$  of the red pens and 25% of the green pens to his classmate. What percentage of the pens had he left?

- (1) 24%  
 (2) 55%  
 (3) 71%  
 (4) 76%

( )

14. The numbers, 1 to 19 are arranged as shown in the table below.

K	L	M	N
1	2	3	
	6	5	4
7	8	9	
	12	11	10
13	14	15	
	18	17	16
19	...		

In which column, K, L, M or N, will the number 193 appear?

- (1) K  
 (2) L  
 (3) M  
 (4) N

( )

15.  $\frac{1}{2}$  of A is equal to  $\frac{2}{3}$  of B.  $\frac{1}{3}$  of B is equal to  $\frac{2}{3}$  of C. What is A : B : C?

- (1) 4 : 6 : 3  
 (2) 4 : 3 : 1  
 (3) 8 : 2 : 1  
 (4) 8 : 6 : 3

( )

**End of Booklet A**

Pei Chun Public School  
Semestral Assessment 1 – 2009  
Mathematics  
Primary 6

**Paper 1 (Booklet B)**  
You are not allowed to use a calculator.

Name : \_\_\_\_\_ ( )

Marks :

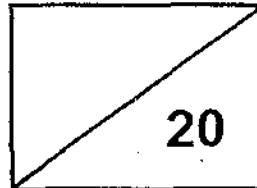

Class : Primary 6 \_\_\_\_\_

Date : 14 May 2009

Total Time for Booklets A and B: 50 min

Maths Teacher : \_\_\_\_\_

Parent's Signature : \_\_\_\_\_

Questions 16 to 25 carry 1 mark each. Write your answers in the spaces provided.  
For questions which require units, give your answers in the units stated. ( 10 marks )

Do not write  
in this space

16. What is the missing number in the box?

$$708\,603 = 700\,000 + 8000 + \boxed{\phantom{000}} + 3$$

Ans : \_\_\_\_\_

17. The population of a town is 546 925.  
Round off this number to the nearest thousand.

Ans : \_\_\_\_\_

SCORE

59

18. How many faces does the prism have?

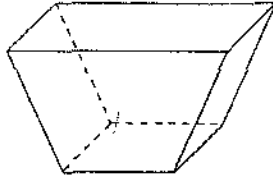

Ans : \_\_\_\_\_

19. The figure shows some roads on a map.

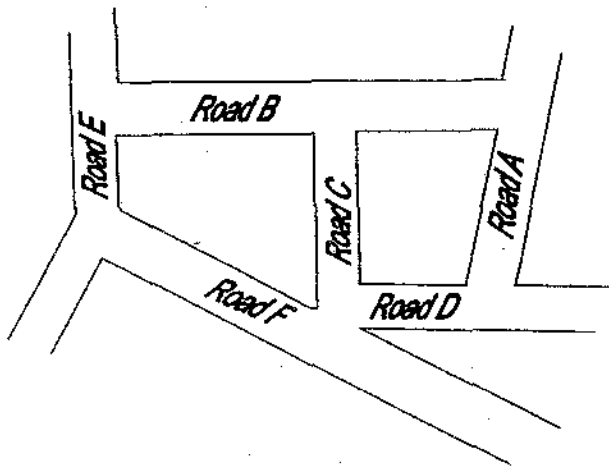

Which road is parallel to Road B?

Ans : \_\_\_\_\_

20. Mr Wong arranges his collection of coins in piles of 49. He has 8 piles.  
How many coins are there altogether?

Ans : \_\_\_\_\_

21. What is the missing number in the box?

$$424 \times \boxed{\phantom{000}} = 848$$

Ans : \_\_\_\_\_

60

SCORE

--

22. There are 36 pupils in a class.  $\frac{2}{3}$  of them come to school by bus. How many pupils do **not** come to school by bus?

Ans : \_\_\_\_\_

23. What is the value of  $\frac{2}{3} - \frac{1}{4}$ ?

Ans : \_\_\_\_\_

24. A wheel makes  $\frac{1}{2}$  of a revolution in one second. How many revolutions does it make in a minute?

Ans : \_\_\_\_\_

25. The ratio of the number of Larry's stamps to the number of Collin's stamps is 7 : 9. Collin gives  $\frac{1}{3}$  of his stamps to Larry. What is the new ratio of the number of Larry's stamps to the number of Collin's stamps?

Ans : \_\_\_\_\_

SCORE

41

Questions 26 to 30 carry 2 marks each. Show your working clearly in the space below each question and write your answers in the spaces provided. For questions which require units, give your answers in the units stated. (10 marks)

Do not write in this space

26. Eliza has a rectangular piece of wood measuring 12 cm by 8 cm by 9 cm. She wants to cut the wood into 3-cm cubes. What is the **greatest** number of 3-cm cubes that Eliza can cut from the piece of wood?

Ans : \_\_\_\_\_

27. In the figure below,  $\angle XYZ = 54^\circ$  and  $\angle VZW = 30^\circ$ .  $VXW$  is an equilateral triangle.  $XVY$ ,  $XWZ$  and  $YZ$  are straight lines. Find  $\angle YZV$ .

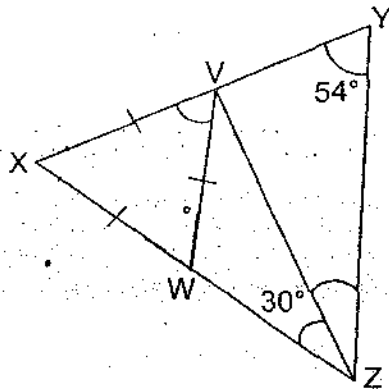

Ans : \_\_\_\_\_

42

SCORE

28. In a hall,  $\frac{1}{6}$  of the people were children. 60% of the adults were men. There were 48 more men than children. How many men were there in the hall?

Ans : \_\_\_\_\_

29. The graph shows the number of siblings the pupils in a class have.

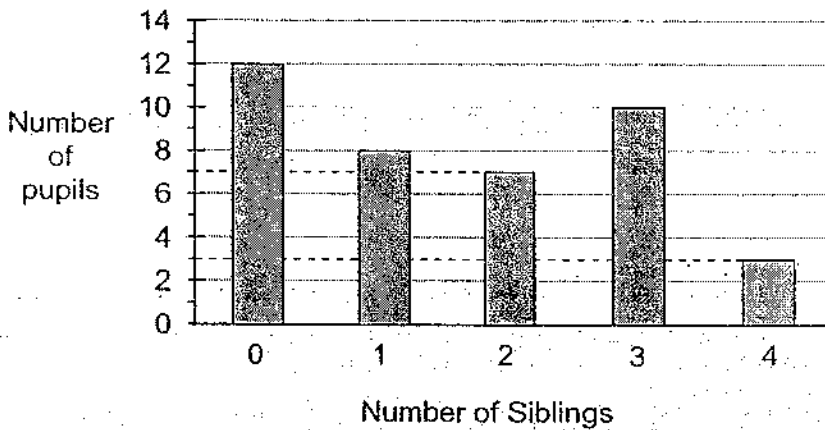

What percentage of the pupils have at least 2 siblings?

Ans : \_\_\_\_\_ %

SCORE

43

30. A rectangular piece of paper is cut into 4 smaller rectangles as shown in the figure below. What is the area of rectangle S?

Do not write  
in this space

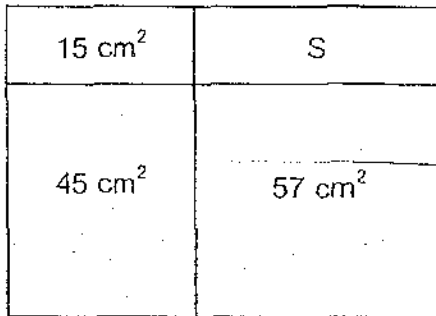

Ans : \_\_\_\_\_  $\text{cm}^2$

---

**End of Booklet B**

Set by : Ms Jennifer Foo  
Vetted by : P6 Mathematics Committee Teachers

MP

--

Pei Chun Public School  
Semestral Assessment 1 – 2009  
Mathematics  
Primary 6

**Paper 2**  
You are allowed to use a calculator.

Name : \_\_\_\_\_ (      )

Class : Primary 6

Date : 14 May 2009

Time : 1 h 40 min

Maths Teacher : \_\_\_\_\_

Parent's Signature : \_\_\_\_\_

Marks :

<b>Paper 1</b> (Booklet A)	20
<b>Paper 1</b> (Booklet B)	20
<b>Paper 2</b>	40
<b>Booklet K</b> Qn 4, 5, Qn 15 – Qn 18	20
<b>TOTAL</b>	<b>100</b>

Questions 1 to 3 carry 2 marks each. Show your working clearly in the space provided for each question and write your answers in the spaces provided. For questions which require units, give your answers in the units stated. ( 6 marks )

1. Mr Low had \$780 and Mr Kunalan had \$526. Each of them spent the same amount of money. Mr Low had three times as much money left as Mr Kunalan. How much did each of them spend?

Ans : \$ \_\_\_\_\_

SCORE

45

2. Kim had some sweets. She gave  $\frac{1}{4}$  of her sweets to her sister and  $\frac{1}{6}$  of the remainder to her brother. After buying 12 more sweets, she had  $\frac{7}{8}$  of the sweets that she had at first. How many sweets did Kim have at first?

Ans : \_\_\_\_\_

3. Mr Wong drove at 81 km/h for  $\frac{1}{3}$  h and then at 76 km/h for  $\frac{1}{2}$  h. What was his average speed for the whole journey in km/h?

Ans : \_\_\_\_\_ km/h

4. Refer to Booklet K.  
5. Refer to Booklet K.

SCORE

For questions 6 to 14, show your working clearly in the space provided for each question and write your answers in the spaces provided.  
The number of marks available is shown in brackets [ ] at the end of each question or part-question. (Total: 34 marks)

Do not write  
in this space

6. The figure shows two straight lines PQ and QR.

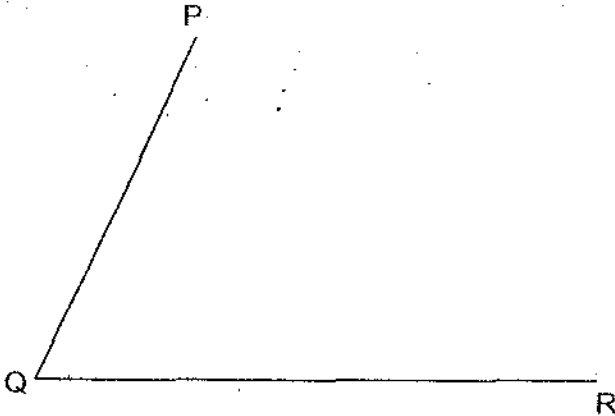

- (a) Measure and write down the size of  $\angle PQR$ .
- (b) Lines PQ and QR are two sides of a parallelogram. Draw the parallelogram by completing the figure above. [2]

Ans : (a) \_\_\_\_\_ [1]

7. Leonard sat for five Mathematics tests in a year. His average score for the first three tests was 89 and his average score for all the five tests was 86. Leonard scored 15 fewer marks in the fourth test than the fifth test.

- (a) What was the total score of Leonard's first three tests?
- (b) What was Leonard's score for the fourth test?

(a)

(b)

Ans : (a) \_\_\_\_\_ [1]

(b) \_\_\_\_\_ [2]

SCORE

47

8. The figure below is made up of a square and a triangle. The perimeter of the square is 36 cm.

Do not write  
in this space

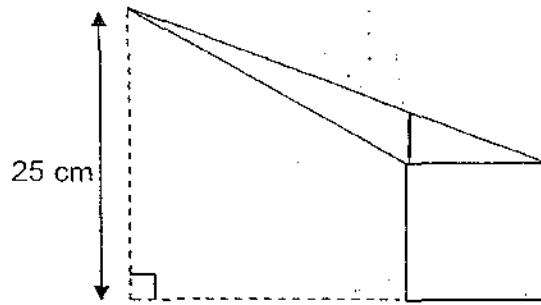

- (a) What is the length of the square?  
(b) What is the area of the triangle?

Ans : (a) \_\_\_\_\_ [1]

(b) \_\_\_\_\_ [2]

48

SCORE

--

9. Bag X and Bag Y contained some marbles. Bag X had 304 marbles fewer than Bag Y. After 52 marbles from Bag X were taken out and put into Bag Y, there were five times as many marbles in Bag Y as in Bag X. How many marbles were there in Bag Y at first?

Do not write  
in this space

Ans : \_\_\_\_\_ [3]

SCORE

49
----

10. A certain number of beads can be arranged in exactly 18 beads per row. If the beads are arranged in rows of 11, there will be 8 more rows and 3 beads left over. How many beads are there altogether?

Do not write  
in this space

Ans : \_\_\_\_\_ [4]

50

SCORE

Do not write  
in this space

11. A lorry set off from Town P at 7.45 a.m. at an average speed of 80 km/h and reached Town Q at 9.45 a.m. A van set off from Town P 2 hours earlier and reached Town Q at the same time as the lorry.

- (a) What was the average speed of the van?
- (b) If the van increased its average speed by 10 km/h, how much earlier would it have reached Town Q?

Ans: (a) \_\_\_\_\_ [2]

(b) \_\_\_\_\_ [2]

SCORE

--

71

Do not write  
in this space

12. A book seller sold three times as many magazines as comic books. He received a total of \$2376. Each magazine cost  $1\frac{1}{2}$  times as much as a comic book. If each magazine cost \$18, how many **more** magazines than comic books did he sell?

Ans : \_\_\_\_\_ [5]

52

SCORE

13. The figures below show three rectangular tanks, A, B and C. Tank A is half filled with water, Tank B is empty and Tank C contains water to a height of 5 cm.

- (a) How much water is there in Tank A?
- (b) The water is poured from Tank A without spilling into Tank B and Tank C in the ratio 2 : 3. How many litres of water are there in Tank C now?  
(1 l = 1000 cm<sup>3</sup>)

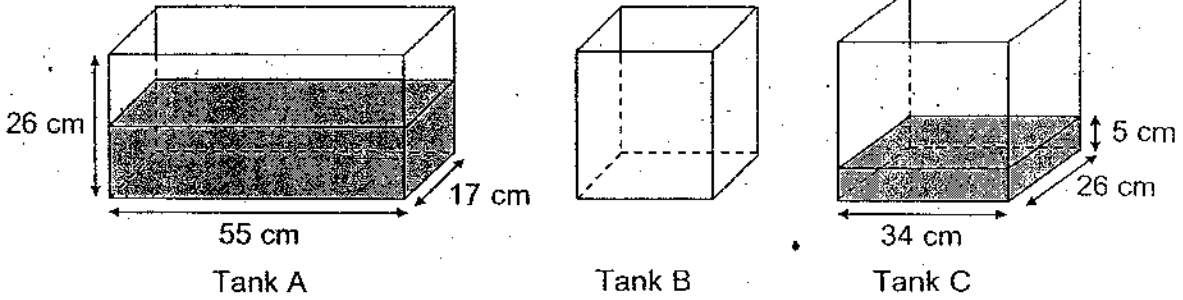

Ans : (a) \_\_\_\_\_ [1]

(b) \_\_\_\_\_ [4]

SCORE

--

14. Ann and Ben collect postcards and stamps. Ben has 30 more stamps than postcards. Ben also has twice the number of postcards Ann has, and Ann has 50% more stamps than Ben. After Ann gives Ben all of her postcards and Ben gives Ann 50% of his stamps, Ben has 75 more postcards than stamps. Find the number of stamps Ann has at first.

Ans : \_\_\_\_\_ [4]

15. Refer to Booklet K.

16. Refer to Booklet K.

17. Refer to Booklet K.

18. Refer to Booklet K.

54

**End of Paper 2**

Set by : Ms Jennifer Foo  
Vetted by : P6 Mathematics Committee Teachers

SCORE

--

# ANSWER SHEET

## EXAM PAPER 2009

SCHOOL : PEI CHUN PRIMARY  
SUBJECT : PRIMARY 6 MATHEMATICS

TERM : SA1

Q1	Q2	Q3	Q4	Q5	Q6	Q7	Q8	Q9	Q10	Q11	Q12	Q13	Q14	Q15
2	4	3	1	1	4	3	2	3	2	2	3	4	1	4

- 16)600      17)547000      18)6 faces      19)Road D      20)392 coins  
21)2      22)12 pupils      23)5/12      24)30      25)5:3  
26)24 cubes      27)36°      28)72 men      29)50%      30)19cm<sup>2</sup>

## Paper 2

1) Difference  $\rightarrow (780-526) \div 2 = 127$   
Spent  $\rightarrow 526 - 127 = \$399$

2) 2 units  $\rightarrow 12$   
At first  $\rightarrow 12/2 \times 8 = 48$

3) Total journey  $\rightarrow 81 \times 1/3 + 76 \times 1/2 = 65$   
Total time  $\rightarrow 1/3 \text{h} + 1/2 \text{h} = 50 \text{min}$   
Ave speed  $\rightarrow 65 \div 50/60 = 78 \text{km/h}$

4 to 5 no ques

6) a) 65°      b)

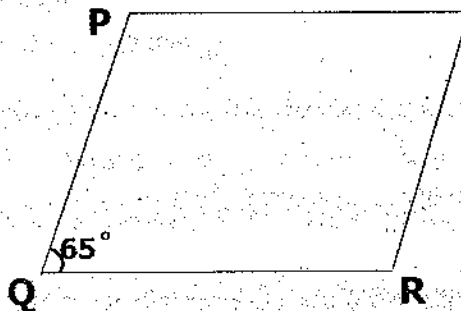

7)a)267

b)74

8)a)length $\rightarrow 36 \div 4 = 9\text{cm}$

b)25-9=16

Area of triangle $\rightarrow \frac{1}{2} \times 16 \times 9 = 72\text{cm}^2$

9)458

10)234 beads

11)a)40km/h

b)48min

12)1 book $\rightarrow 18/3 \times 2 = \$12$

1 set $\rightarrow 18 \times 3 + 12 = 66$

? sets $\rightarrow 2376 \div 66 = 36$

? magazines $\rightarrow 36 \times 3 = 108$

More $\rightarrow 108/3 \times 2 = 72$

13)a)water $\rightarrow (26 \div 2) \times 17 \times 55 = 12155\text{cm}^3$

b)Poured in C $\rightarrow 12155/5 \times 3 = 7293$

C now $\rightarrow (34 \times 26 \times 5) + 7293 = 11713\text{cm}^3$   
 $= 11.713\text{ml}$

14)2 units $\rightarrow 75 + 15 = 90$

1 unit $\rightarrow 90 \div 2 = 45$

Ann stamps at first $\rightarrow 3 \times 45 + 30 + 15 = 180$