



HENRY PARK PRIMARY SCHOOL
PRELIMINARY EXAMINATION 2009
MATHEMATICS
PRIMARY 6

PAPER 1
(BOOKLET A)

Name: _____ ()

Class: Primary 6 _____

Total Time for Booklets A and B: 50 min

Do not turn over this page until you are told to do so.

Follow all instructions carefully.

Answer all questions.

Shade your answers in the Optical Answer Sheet (OAS) provided.

You are **not** allowed to use a calculator.

Questions 1 to 10 carry 1 mark each. Questions 11 to 15 carry 2 marks each.
For each question, four options are given. One of them is the correct answer.
Make your choice (1, 2, 3 or 4). Shade the correct oval (1, 2, 3 or 4) on the
Optical Answer Sheet. (20 marks)

1. What is the value of $200 - 50 + 5 - 5 \times 3 - 15$?

- (1) 190
- (2) 160
- (3) 60
- (4) 0

()

2. There are $\frac{2}{5}$ as many girls as boys in a class.

What fraction of the pupils in the class are boys?

- (1) $\frac{2}{7}$
- (2) $\frac{3}{5}$
- (3) $\frac{5}{7}$
- (4) $\frac{4}{5}$

()

3. The height of the classroom door is about _____.

- (1) 0.02 m
- (2) 0.2 m
- (3) 200 cm
- (4) 2000 cm

()



4. Find the area of shaded triangle shown below.

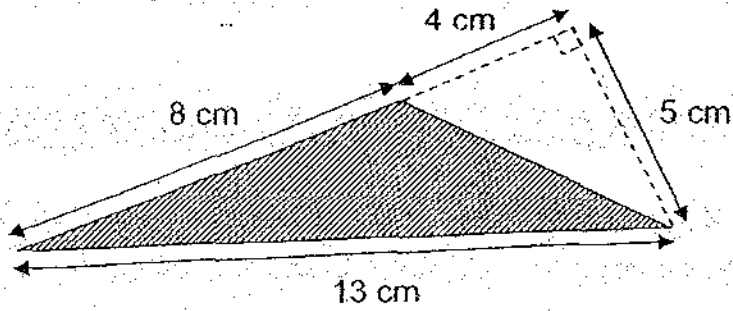

- (1) 20 cm^2
(2) 30 cm^2
(3) 32.5 cm^2
(4) 52 cm^2

()

5. Simplify $6r + 5 - 3r + 4$

- (1) $3r + 1$
(2) $3r + 9$
(3) $9r + 1$
(4) $9r + 9$

()

6. The ratio of the number of dogs to the number of cats at a pet hotel was 4 : 5. If there were 72 dogs and cats altogether, how many cats were there?

- (1) 8
(2) 32
(3) 40
(4) 45

()



7. The table below shows the monthly Math test scores of 4 pupils. Use the information in the table to answer the following question. Which pupil has shown the most improvement in his test scores from Jan to Apr?

	Alex	Ben	Calvin	Daniel
Jan	56	40	41	37
Feb	54	44	49	53
Mar	57	70	54	59
Apr	43	77	60	66

- (1) Alex
 (2) Ben
 (3) Calvin
 (4) Daniel

()

8. In the diagram below, Andy is standing at point P facing the temple. Which place will he be facing if he turns 270° anti-clockwise?

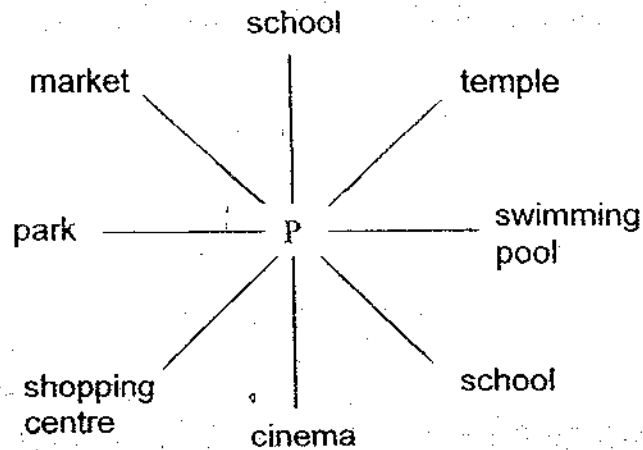

- (1) market
 (2) park
 (3) school
 (4) swimming pool

()



9. In the figure below, PQR is an equilateral triangle, PRS is an isosceles triangle and QS is a straight line. Find $\angle m$.

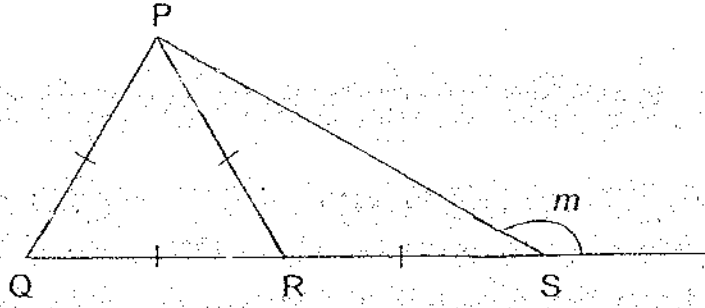

- (1) 60°
 (2) 120°
 (3) 150°
 (4) 170°
10. The pie chart below represents a group of pupils' favourite fast food outlets.

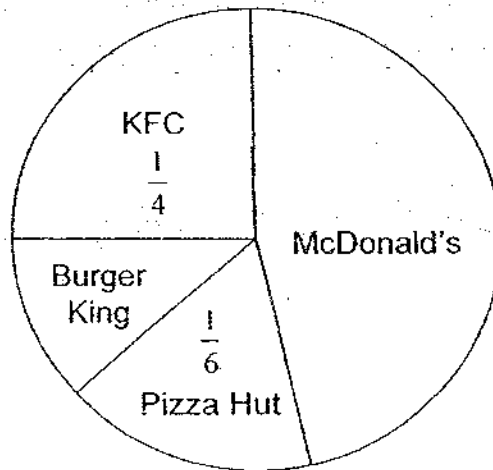

10 pupils chose Pizza Hut as their favourite fast food outlet. The number of pupils who chose McDonald's as their favourite fast food outlet was 4 times the number of pupils who chose Burger King.

How many pupils chose McDonald's as their favourite fast food outlet?

- (1) 7
 (2) 15
 (3) 28
 (4) 40



11. In a Math quiz, the average score of a group of 12 pupils is 7 marks while the average score of another group of 8 pupils is 9 marks. What is the average score of these 20 pupils?

- (1) 7.8
- (2) 8.0
- (3) 10.0
- (4) 16.0

12. Which one of the following statements is **NOT** correct?

- (1) $267.8 \div 1000 = 0.2678$
- (2) $2678 \div 100 = 26.78$
- (3) $2.678 \times 1000 = 2678$
- (4) $26.78 \times 100 = 2600 + 70 + 8$

13. Two machines were used to print 4500 similar sheets of pamphlet. Every minute Machine A printed 150 more sheets than Machine B. Machine A broke down after the two machines had together printed 1500 sheets in 6 minutes. How much more time was required to print the rest of the sheets using Machine B alone?

- (1) 20 min
- (2) 60 min
- (3) 66 min
- (4) 90 min



14.

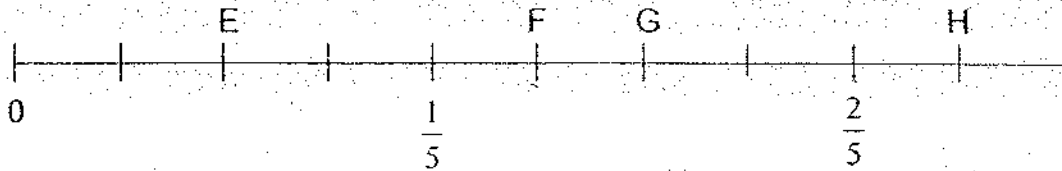

In the number line above, how much longer is EH than FH?

- (1) 0.15
- (2) 0.20
- (3) 0.60
- (4) 0.75

()

15. A rectangular piece of paper was folded twice at the two ends to form the shape as shown below. Find the perimeter of the original piece of paper.

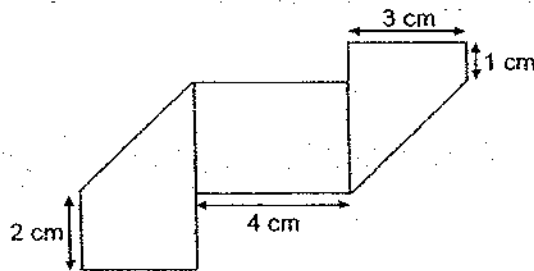

- (1) 16 cm
- (2) 20 cm
- (3) 26 cm
- (4) 32 cm

()





HENRY PARK PRIMARY SCHOOL
PRELIMINARY EXAMINATION 2009
MATHEMATICS
PRIMARY 6

PAPER 1
(BOOKLET B)

Name: _____ ()

Class: Primary 6 _____

Total Time for Booklets A and B: 50 min

Do not turn over this page until you are told to do so.

Follow all instructions carefully.

Answer all questions.

Write your answers in this booklet.

You are **not** allowed to use a calculator.

Questions 16 to 25 carry 1 mark each. Write your answers in the spaces provided.
For questions which require units, give your answers in the units stated. (10 marks)

16. Write 3 thousands, 4 ones, 6 tenths and 18 hundredths as a decimal.

Ans: _____

17. Arrange these fractions from the largest to the smallest:

$$\frac{9}{8}, \quad \frac{4}{3}, \quad 1\frac{2}{9}$$

Ans: _____

18. A rectangular container has a volume of $6\,400\text{ cm}^3$. The perimeter of its square base is 32 cm. What is the height of the container?

Ans: _____ cm



19. The diagram below is made up of 4 semicircles. The diameter of the biggest semicircle is 28 cm. Find the perimeter of the shaded figure. Express the answer in terms of π .

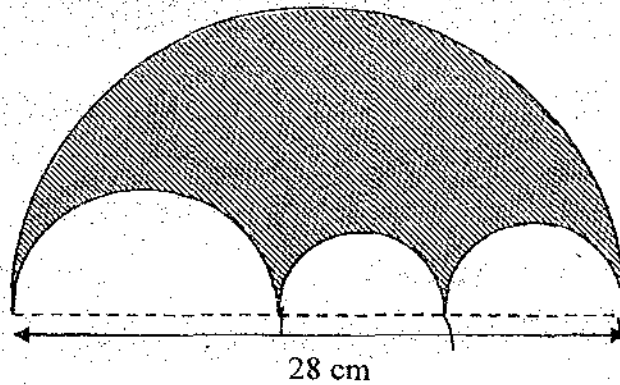

Ans: _____ cm

20. Singapore is 1 hour behind the time in Tokyo, Japan.
Sally's plane left Tokyo for Singapore at 6 p.m. (Japan time). If the flight took 6 hours, at what time in Singapore did Sally arrive? Give your answer in 24-hour clock.

Ans: _____



21. The average of 3 different odd numbers is 5. What is the largest possible value of one of the numbers?

Ans: _____

22. The table below shows a reading record of the number of books read by a group of pupils in a week.

Number of books per pupil	Number of pupils
0	11
1	10
2	7
3	2

What is the average number of books read by the pupils?

Ans: _____

23. Shade one more square in the figure to make it symmetrical.

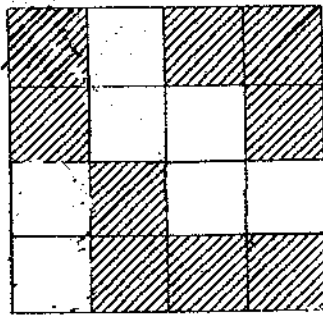

24. The figure below shows the net of a cube.

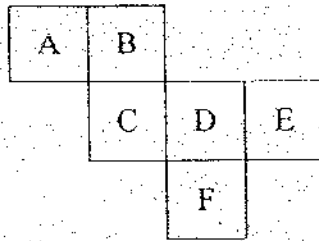

What is the letter opposite to 'F' on the cube?

Ans: _____

25. During the Great Singapore Sale, a bakery gave away a free ring doughnut for every four similar ring doughnuts bought. What was the percentage discount the bakery was offering for this particular promotion?

Ans: _____ %



Questions 26 to 30 carry 2 marks each. Show your working clearly in the space provided for each question and write your answers in the spaces provided.

For questions which require units, give your answers in the units stated. (10 marks)

26. Mohamad bought a watch using only \$5 notes to pay to the shopkeeper. If he were to use \$2 notes instead of \$5 notes to pay for the watch, he would use 36 more notes. How much did he pay for the watch?

Ans: \$ _____

27. At first, Mary, Steven and Terry had the same number of stamps. After Steven and Terry had each given a quarter of their stamps to Mary, she had 18 stamps in the end. How many stamps did the 3 children have altogether?

Ans: _____



28. Two cubes are glued together to make a cuboid as shown below.

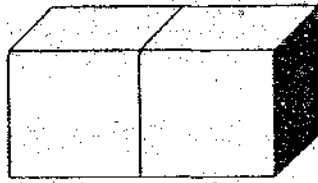

The total length of the cuboid's edges is 48 cm.

What is the volume of the cuboid?

Ans: _____ cm^3

29. The ratio of the number of girls to the number of boys in a library was 4 : 5. After a group of boys entered the library, 40% of the new total number of children were girls. What was the percentage increase in the number of boys?

Ans: _____ %



30. Shade in the diagram below the **unit shape** used for the tessellation.
Extend the tessellation by drawing another **2 more** unit shapes in the space provided.

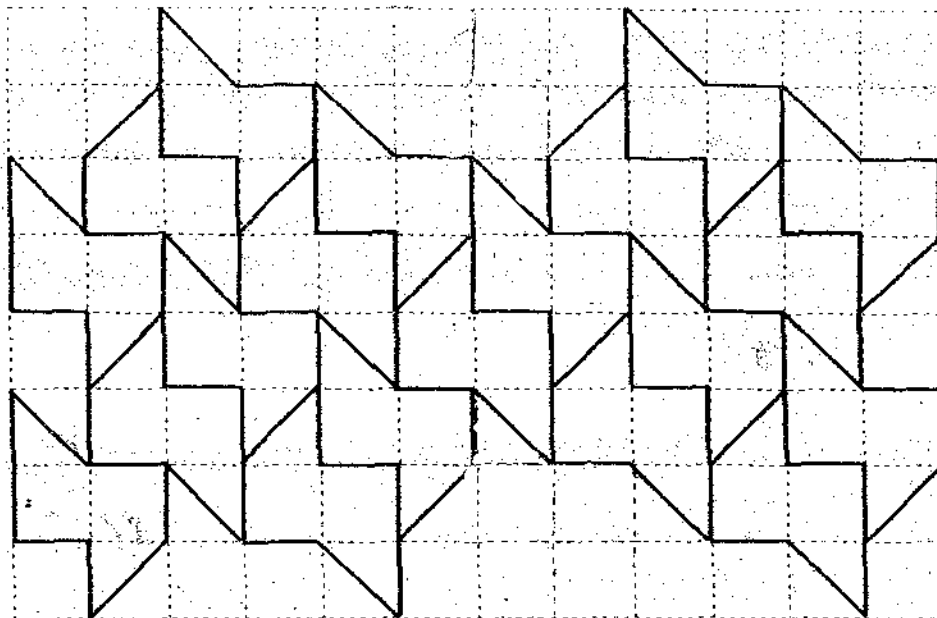

END OF PAPER

Setters: Mr Lim Ming Liang
Ms Theresa Heng

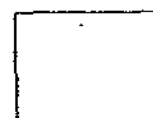



HENRY PARK PRIMARY SCHOOL
PRELIMINARY EXAMINATION 2009
MATHEMATICS
PRIMARY 6

PAPER 2

Name: _____ ()

Class: Primary 6

Time for Paper 2: 1 h 40 min

Do not turn over this page until you are told to do so.

Follow all instructions carefully.

Answer all questions.

Show your working clearly as marks are awarded for correct working.

Write your answers in this booklet.

You are allowed to use a calculator.

Questions 1 to 5 carry 2 marks each. Show your working clearly in the space provided for each question and write your answers in the spaces provided.

For questions which require units, give your answers in the units stated. (10 marks)

1. Find the maximum number of 3-cm cubes that can be placed in a cuboid 25 cm by 16 cm by 20 cm.

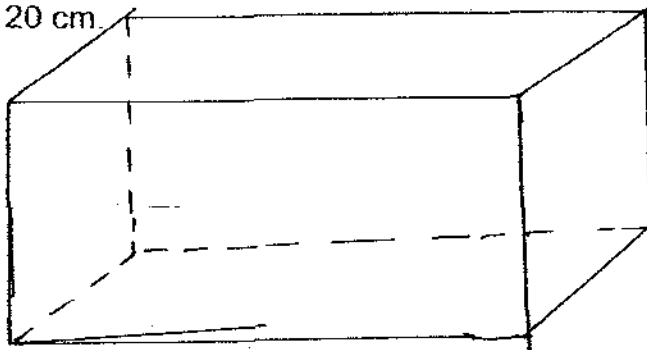

Ans: _____

2. The table below shows the taxi fare charges in a city.

Taxi Fare Charges

For the first 1 km or less	\$2.60
Every 1 km thereafter or less up to 10 km	\$0.80
Every 1 km thereafter or less after 10 km	\$0.50

How much taxi fare will Junde need to pay if he travels a total distance of 7.8 km by taxi?

Ans: \$ _____

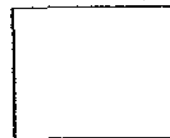

3. Mrs Leong had some stickers. She gave half of what she had to her daughter and son. Her daughter received $\frac{1}{3}$ of what her son received. What fraction of the stickers did Mrs Leong give to her son?

Ans: _____

4. The square below is made up of 4 identical rectangles. The perimeter of each rectangle is 20 cm. Find the breadth of the rectangle.

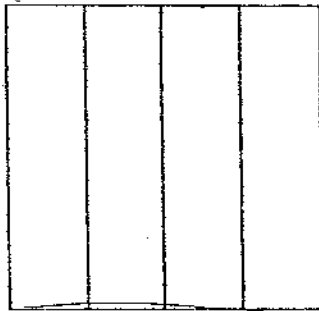

Ans: _____ cm



5. The incomplete graph below shows the number of hotdogs, popcorn and ice-cream that Jenny sold at a food fair.

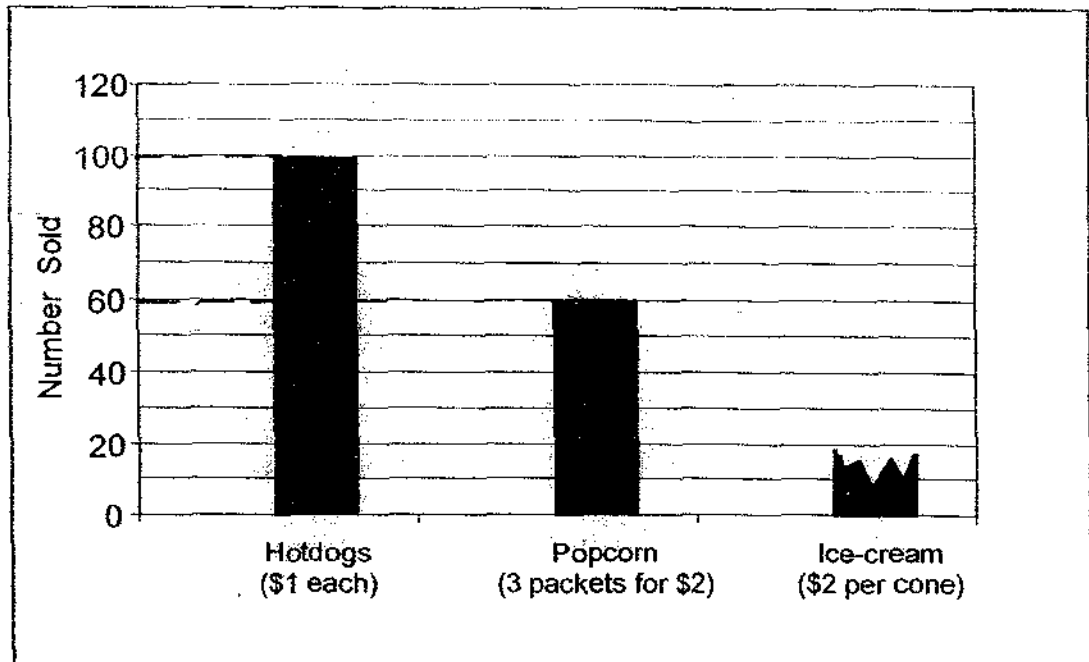

Jenny collected \$200 from the sale. How many cones of ice-cream were sold at the food fair?

Ans: _____

110



For questions 6 to 18, show your working clearly in the space provided for each question and write your answers in the spaces provided.
The number of marks available is shown in brackets [] at the end of each question or part-question. (50 marks)

6. Sharon bought m pens and 3 notebooks for \$5. Each pen cost 40 cents.
(a) Express the cost of 1 notebook in terms of m .
(b) If $m = 5$, how much did each notebook cost?

Ans: (a) _____ [2]

(b) _____ [1]

7. Mrs Sim bought 15 handbags for \$267.30. $\frac{3}{5}$ of these handbags cost the same price. Each of the remaining handbags cost 3 times as much.
Find the difference in the price of the 2 types of handbags.

Ans: _____ [3]

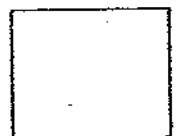

8. The shaded figure below is formed inside four identical squares of sides 6 cm. Find the shaded area.

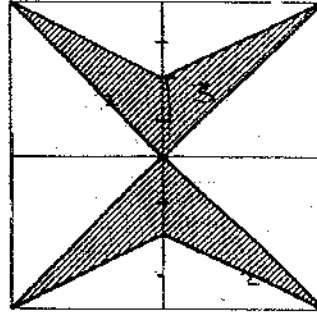

Ans: _____ [3]

9. Wei Qing played with Ravi in a game of chess for twelve rounds. In each round, the winner scored 5 points while the loser scored 2 points. At the end of the game, Ravi's total score was 45 points. How many rounds did Wei Qing win?

Ans: _____ [3]



10. (a) In the space below, draw a rhombus ABCD in which $\angle ADC = 120^\circ$.

The line AB has been drawn for you.

[2]

(b) Draw the line AC in the diagram. How long is the line AC?

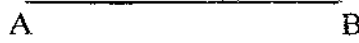

Ans: (b) _____ [1]

7



11. In the figure below, O is the centre of a semi-circle. $PQ = PR$, $PQ \parallel SU$ and $\angle PTO = 110^\circ$.

(a) Find $\angle m$.

(b) Find $\angle n$.

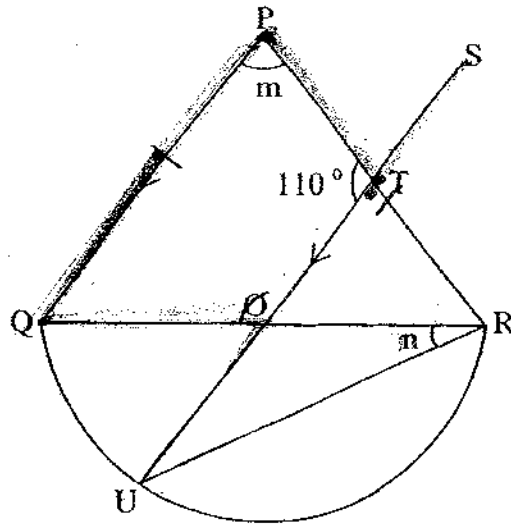

Ans: (a) _____ [1]

(b) _____ [3]

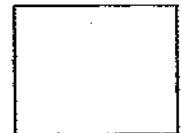

12. Tank P was filled with water as shown in the diagram below. Water was then poured from Tank P to Tank Q until the height of the water level in Tank P became twice that of the water level in Tank Q. Find the volume of water in Tank Q. Give your answer in litres.

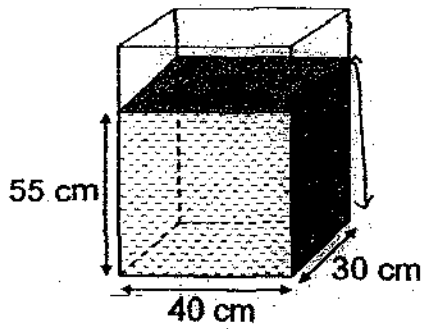

Tank P

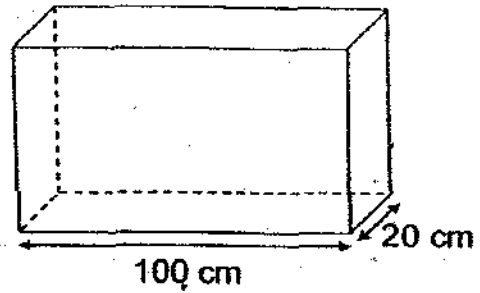

Tank Q

Ans: _____ [4]

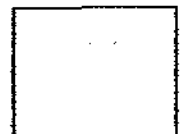

13. A van travelled from Town A to Town B at an average speed of 55 km/h. A car started its journey from Town B to Town A at the same time as the van, travelling at an average speed of 90 km/h. The two vehicles passed each other 70 km from the middle of the whole journey. Find the distance between the two towns.

Ans: _____ [4]



14. Cinema admission tickets for children were priced at \$8 each. There were 20 more boys than girls in the cinema for the first movie. For the second movie, the number of boys decreased by 10% but the number of girls increased by 5%. If there were 408 children at the second movie, how much money was collected from the sales of admission tickets for the first movie?

Ans: _____ [4]



15. A librarian counted the number of adults in the library and found that $\frac{2}{5}$ of the number of women was equal to 2 times the number of men. When another 12 men entered the library and 45 women left the library, the ratio of the number of women to the number of men became 5 : 2.

- (a) What was the ratio of the number of women at first to the number of men at first? Give your answer in its simplest form.
- (b) Find the number of women in the library at first.

Ans: (a) _____ [1]

(b) _____ [3]

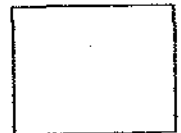

- 16 Elaine's mom gave her money to buy some markers of the same price.
If she bought 8 such markers, she would have \$8 left over.
If she bought 12 such markers, she would have \$6 short.

- (a) How much money did Elaine's mom give her?
(b) How many markers could she buy if her mom were to give her another \$14?

Ans: (a) _____ [3]

(b) _____ [2]

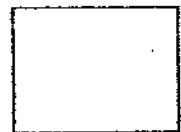

17. The diagram below shows the seating arrangement in an auditorium. The rest of the seats follow the same pattern. *The black boxes represent the seats between seats.*

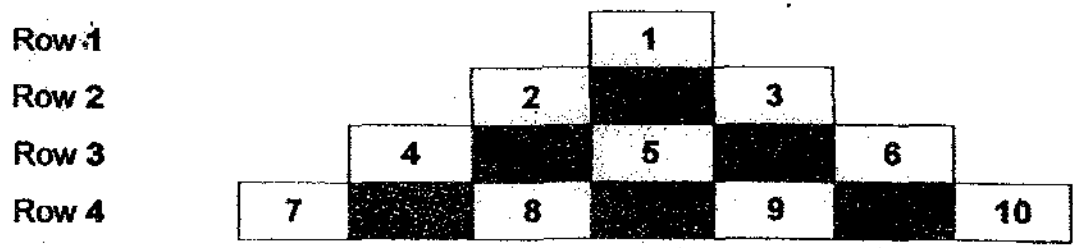

Study the above pattern carefully and answer all the questions that follow.

- (a) How many seats are there in Row 10?
- (b) In which row can we find Seat number 28?
- (c) The first seat number on the left of Row 4 is 7 and the last seat number on the right is 10. If Linda is in the last seat on the right of a secret row and her seat number is 120, in which row will she be?

Ans: (a) _____ [1]
 (b) _____ [2]
 (c) _____ [2]

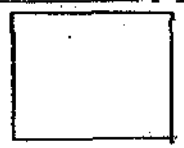

18. The shaded figure below is formed by a semicircle and quarter circles. It lies within the rectangle PQRS in which $RU = 1$ cm, $UQ = 2$ cm and $PT = 3$ cm.

(a) Find the perimeter of the shaded region.

(Give your answer in terms of π .)

(b) Find the area of the shaded region.

(Give your answer correct to 2 decimal places.)

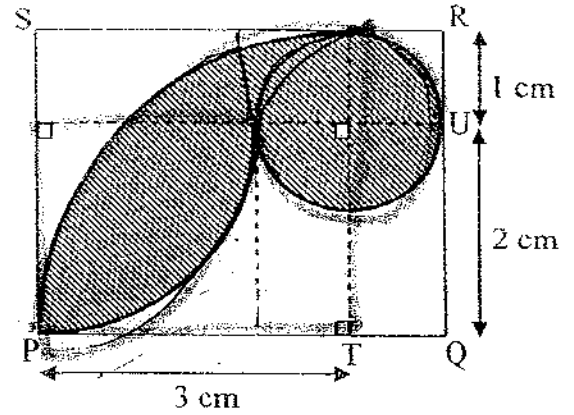

Ans: (a) _____ [2]

(b) _____ [3]

END OF PAPER

Setters: Mr Lim Ming Liang
Ms Theresa Heng

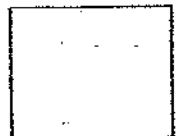

ANSWER SHEET

EXAM PAPER 2009

**SCHOOL : HENRY PARK PRIMARY
SUBJECT : PRIMARY 6 MATHEMATICS**

TERM : SA2

Q1	Q2	Q3	Q4	Q5	Q6	Q7	Q8	Q9	Q10	Q11	Q12	Q13	Q14	Q15
2	3	3	1	2	3	2	3	3	3	1	2	2	1	4

16) 3004.78

17) $4/3, 12/9, 9/8$

18) 100cm

19) 2851cm

20) 2300

21) 11

22) 1

23)

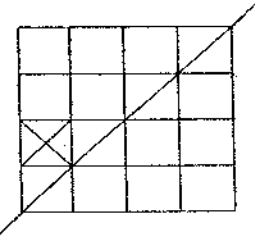

24) B

25) 20%

26) \$120

27) 36

28) 54cm³

29) 20%

30)

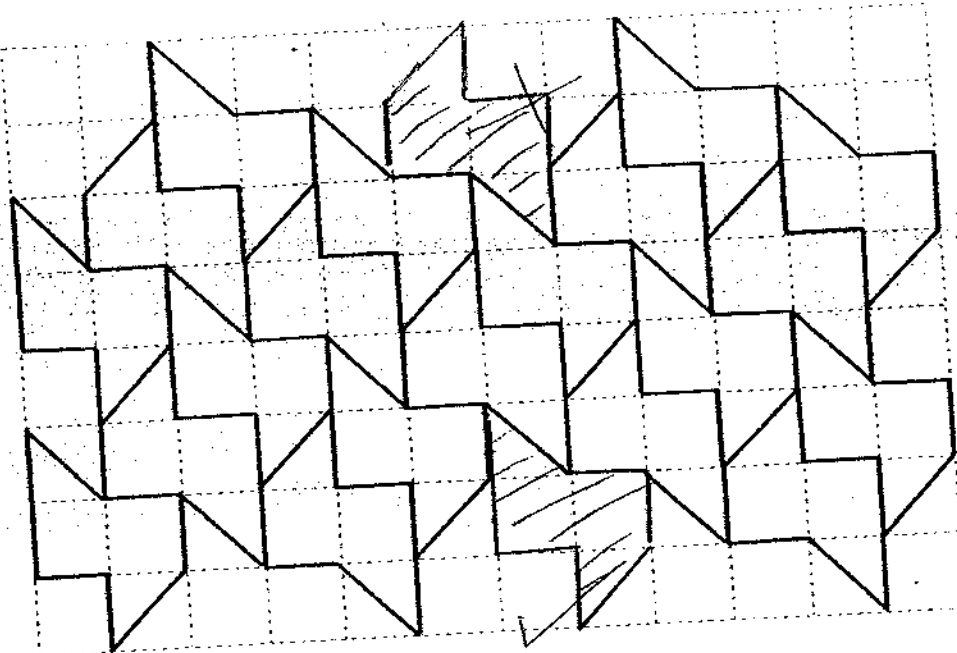

Paper 2

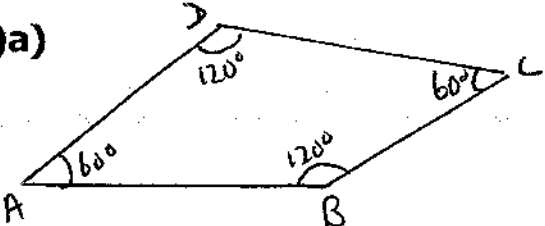
<p>1) 240</p>	<p>2) First 1 km = \$2.60 Next 6.8 km x \$0.80 $\rightarrow 7 \times \\$0.80 = \\5.60 $\\$2.60 + \\$5.60 = \\$8.20$</p>
<p>3) $\frac{3}{8}$</p>	<p>4) 2cm</p>
<p>5) cost of hot dog $\rightarrow 100 \times \\$1 = \\$100$ Cost of popcorn $\rightarrow \\$2(60 \div 3) = \\$2 \times 20 = \\$40$ Cost of ice cream $\rightarrow \\$200 - \\$100 - \\$40 = \\60 $\\$60 \div \\$2 = 30$</p>	<p>6) a) $5 - 0.4$ b) $\\$0.40 \times 5 = \\2 $\\$5 - \\$2 = \\$3$ $\\$3 \div 3 = \\1</p>
<p>7) $\frac{3}{5} \times 15 = 9$ $15 - 9 = 6$ $9 \times 1u = 9u$ $6 \times 3u = 18u$ $18u + 9u = 27u = \\$267.30$ $1u = \\$9.90$ $\\$9.90 \times 2 = \\19.80</p>	<p>8) $12\text{cm} \times 12\text{cm} = 144\text{cm}^2$ $\frac{1}{2} \times 6 \times 3 = 9\text{cm}^2$ $\frac{1}{2} \times 6 \times 6 = 18\text{cm}^2$ $9\text{cm}^2 \times 4 = 36\text{cm}^2$ $18\text{cm}^2 \times 4 = 72\text{cm}^2$ $144\text{cm}^2 - 72\text{cm}^2 - 36\text{cm}^2 = 36\text{cm}^2$</p>
<p>9) 5 rounds</p>	<p>10) a)  b) 7cm</p>

<p>11)a) $m \rightarrow 180^\circ - 110^\circ = 70^\circ$ b) $180^\circ - 70^\circ = 110^\circ$ $110^\circ \div 2 = 55^\circ$ $360^\circ - 55^\circ - 55^\circ = 250^\circ$ $250^\circ \div 2 = 125^\circ$ $180^\circ - 125^\circ = 55^\circ$ $55^\circ \div 2 = 27.5^\circ$</p>	<p>12) $55 \times 40 \times 30 = 66000$ $(40 \times 30 \times 2) + (100 \times 20) = 4400$ $66000 / 4400 = 15$ $15 \times 100 \times 20 = 30000 \text{cm}^3$ = 30L</p>
<p>13) $2 \times 70 \text{km} = 140 \text{km}$ <u>140</u> $90 - 55 = 4 \text{h}$ $(55 + 90) \times 4 = 580 \text{km}$</p>	<p>14) $105\% \text{ G} + 90\% \text{ G} + 18 = 408$ $195\% \text{ G} + 18 = 408$ $100\% \text{ G} = 390 / 195 \times 100$ = 200 $(200 + 200 + 20) \times 8 = \\3360</p>
<p>15)a) 5:1 b) 150</p>	<p>16)a) $12 - 8 = 4$ $8 + 6 = 14$ $14 \div 4 = 3.5$ Cost of 1 maker = \$3.50 $\\$3.50 \times 8 = \\28 $\\$28 + \\$8 = \\$36$ b) $\\$36 + \\$14 = \\$50$ $\\$50 \div \\$3.50 = 14$</p>
<p>17)a) 10 b) row 7 c) row 15</p>	<p>18)a) $\frac{1}{4}(2\pi r) = \frac{1}{4} \times 2 \times \pi \times 2 = 1\pi$ $\frac{1}{4}(2\pi r) = \frac{1}{4} \times 2 \times \pi \times 3 = 1.5\pi$ $\frac{1}{4}(2\pi r) = \frac{1}{4} \times 2 \times \pi \times 1 = 0.5\pi$ $0.5\pi \times 3 = 1.5\pi$ $1\pi + 1.5\pi + 1/5\pi = 4\pi \text{cm}$ b) 6.57cm^2</p>