

Founded 1947

南侨小学

NAN CHIAU PRIMARY SCHOOL

SEMESTRAL ASSESSMENT 1

2009

MATHEMATICS

PRIMARY 4

Section A	20
Sections B & C	80
Total	100

Name: _____ ()

Marks:

Class: Pr 4 _____

Time: 1 h 45 min

Date: 8 May 2009

Parent's Signature: _____

Instructions to Pupils:

1. Do **NOT** open this booklet until you are told to do so.
2. Follow all instructions carefully.
3. Answer all questions.

*This paper consists of **18** pages altogether.

Setter: Mr Erwin

Section A: (20m)

Questions 1 – 10 carry 1 mark each

Questions 11 – 15 carry 2 marks each

For each question, four options are given. One of them is the correct answer. Make your choice (1, 2, 3 or 4). Shade the correct oval (1, 2, 3 or 4) on the Optical Answer Sheet (OAS).

1. There are 25 657 seats in a stadium. Round off this number to the nearest hundred.

- (1) 25 600
- (2) 25 660
- (3) 25 700
- (4) 26 000

2. The value of the digit '5' in 93 531 is _____.

- (1) 5
- (2) 50
- (3) 500
- (4) 5000

3. Study the table carefully.

Group	No. of girls	No. of boys
A	6	6
B	4	5
C	8	7
D	4	8

Which group consists of more girls than boys?

- (1) A
- (2) B
- (3) C
- (4) D

4. The length of one side of a square is 17cm. Find its perimeter.



- (1) 34cm
- (2) 51cm
- (3) 68cm
- (4) 289cm

5. The following graph shows the favourite subject of pupils in a class.

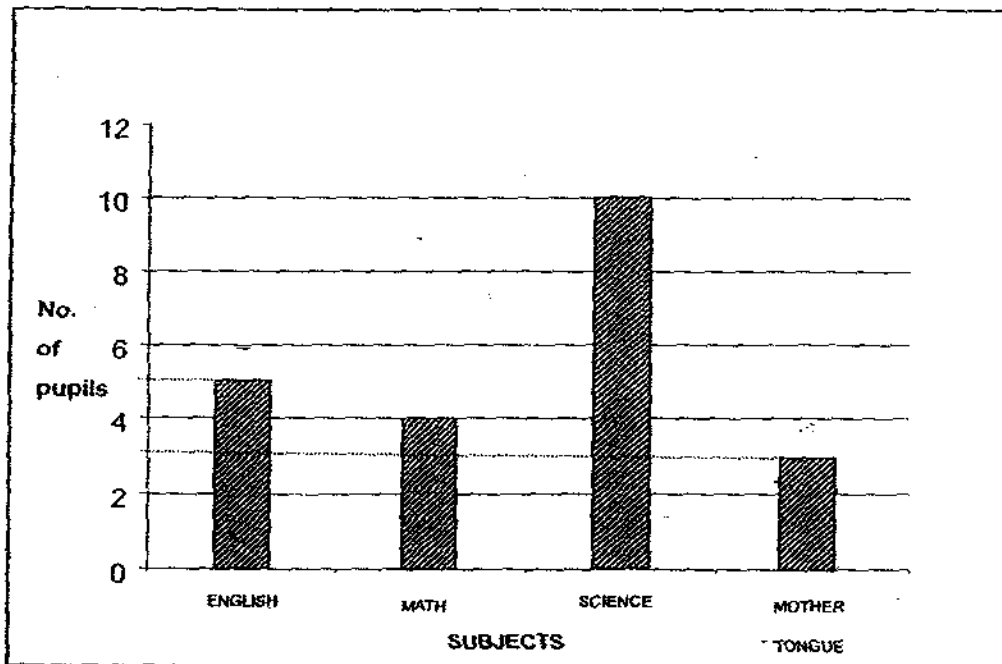

How many more pupils chose Science than Math as their favourite subject?

- (1) 10
- (2) 6
- (3) 5
- (4) 4

6. Find the area of the rectangle below.

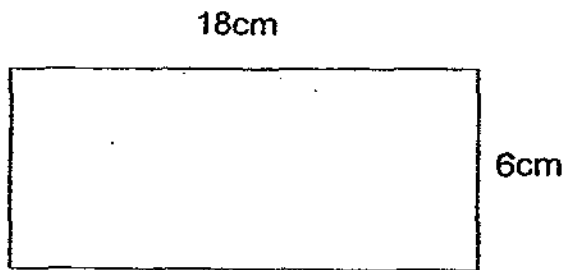

- (1) 24cm^2
- (2) 48cm^2
- (3) 108cm^2
- (4) 324cm^2

7. $\angle DEF$ is a right angle. Find $\angle DEG$.

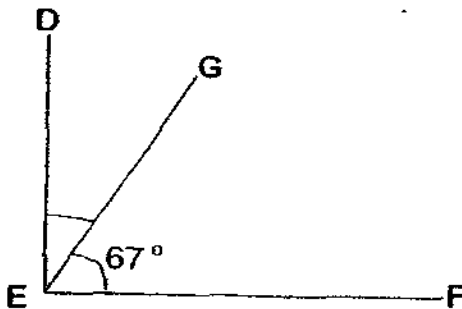

- (1) 23°
- (2) 45°
- (3) 67°
- (4) 90°

8. Which one of the following is NOT equivalent to $\frac{3}{9}$?

(1) $\frac{1}{3}$.

(2) $\frac{2}{6}$

(3) $\frac{6}{12}$

(4) $\frac{5}{15}$

9. $\angle DBA =$ _____ $^\circ$

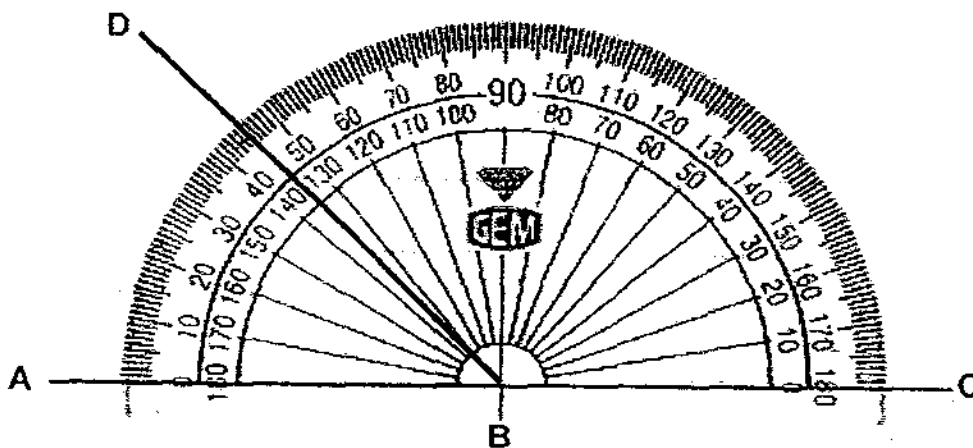

(1) 45

(2) 55

(3) 135

(4) 145

10. $4\frac{2}{7}$ expressed as an improper fraction is _____

(1) $\frac{30}{7}$

(2) $\frac{16}{7}$

(3) $\frac{8}{7}$

(4) $\frac{6}{7}$

11. Danny bought 15 apples. He used $\frac{1}{5}$ of the apples to make pies.

How many apples did he use to make pies?

(1) 1

(2) 5

(3) 3

(4) 14

12. The length of rod A is $\frac{5}{6}$ m. The length of rod B is $\frac{1}{2}$ m. Find the total length of rod A and rod B.

(1) 1 m

(2) $\frac{1}{3}$ m

(3) $\frac{6}{8}$ m

(4) $1\frac{1}{3}$ m

13. Jane bought a total of 1342 red roses and 1442 white roses. She gave all her roses equally to 8 people. How many roses did each person receive?
- (1) 108
 - (2) 348
 - (3) 2776
 - (4) 2784
14. Joe was 68 years old in 2006. How old was he in 1977?
- (1) 29
 - (2) 39
 - (3) 68
 - (4) 97
15. Joe bought a cake. He ate $\frac{2}{3}$ of the cake and gave $\frac{1}{6}$ of it to his sister. What fraction of the cake did he have left?
- (1) $\frac{1}{6}$
 - (2) $\frac{1}{3}$
 - (3) $\frac{2}{3}$
 - (4) $\frac{5}{6}$

Section B: (20 x 2m = 40m)

For each question, write the correct answer in the box provided. Give your answers in the units stated.

16. Round off 2746 to the nearest ten.

17. What is the missing number in the box?

$$34\,753 = 30\,000 + 4000 + \boxed{} + 50 + 3$$

18. What is the eleventh multiple of 8?

19. Find the value of $\frac{1}{4} + \frac{1}{2}$.

20. What is $\frac{4}{5}$ of 60?

21. Find the value of $1 - \frac{3}{7}$.

22. Which one of these figures **does not** have any right angle(s)?

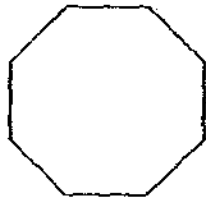

A.

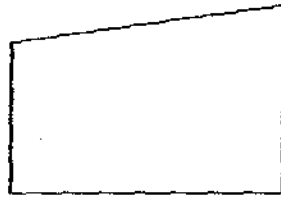

B.

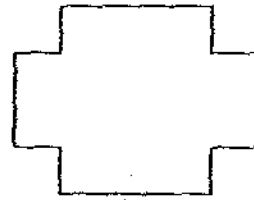

C.

Figure

23. Write down the common factor of 9 and 12 that is greater than 1.

24. In the figure below, JK is perpendicular to _____.

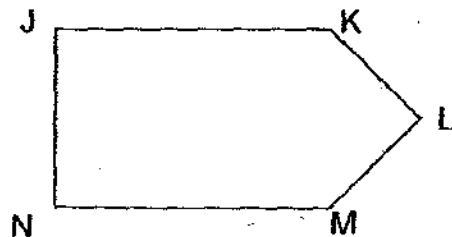

25. Draw a line EF through point E parallel to CD.

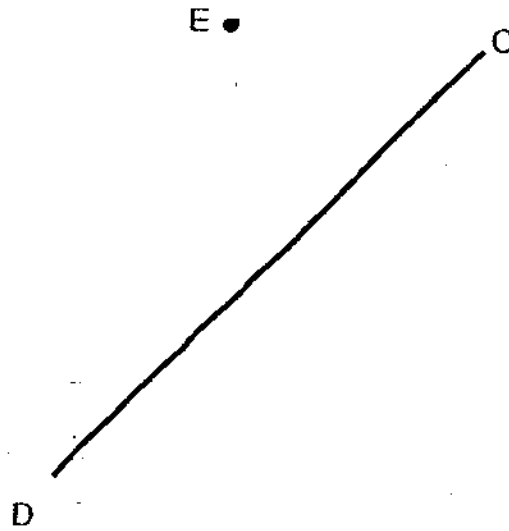

26. The area of a rectangle is 132 m^2 . If the breadth of the rectangle is 6 m, what is its length?

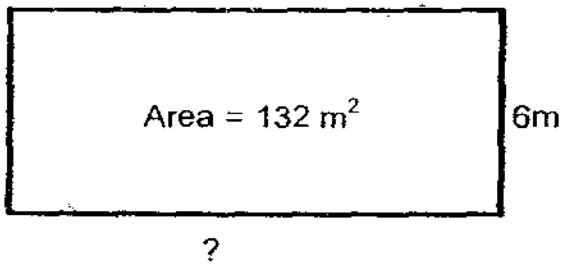

27. Form the largest 5-digit even number with these digits:

6, 7, 1, 9, 2

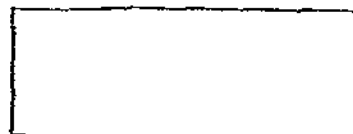

Study the graph below. It shows the number of pupils who achieved Band 1 in Mathematics for the last four years. Use the information to answer Questions 28 and 29.

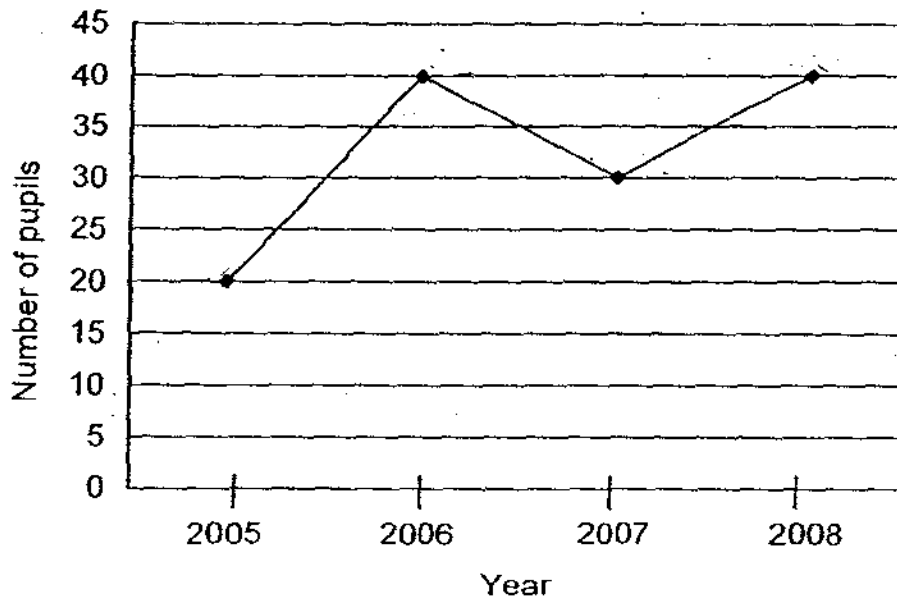

28. How many pupils achieved Band 1 in 2007?

29. What is the total number of pupils who achieved Band 1 in the four years?

30. Change $\frac{27}{12}$ to a mixed number in its simplest form.

31. ABCD is a rectangle. BC is twice as long as CD. Find its perimeter

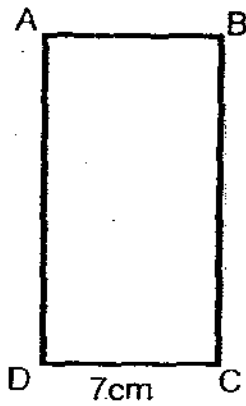
 cm

32. The given figure is made up of three rectangles. Find the total length of AH and CB.

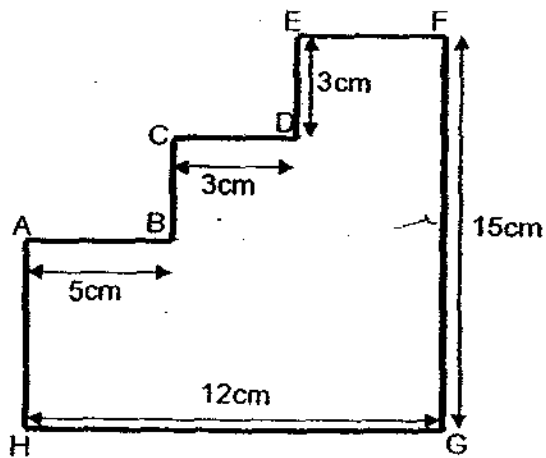
 cm

33. Tom is facing north. If he turns 225° anti-clockwise, which direction will he face?

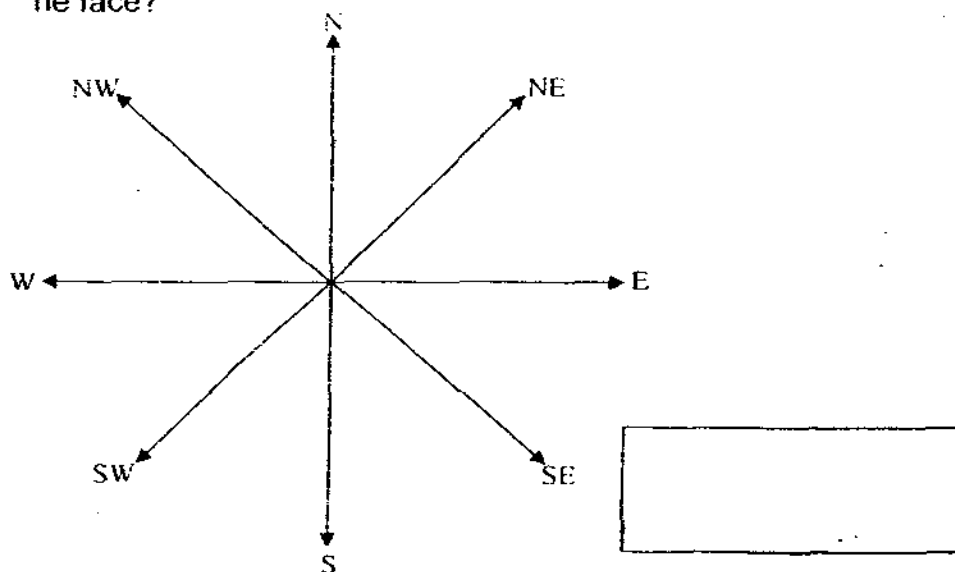

34. There are 4 numbers below.
Find the difference between the greatest number and smallest number.

2090	2990	3099	3909
------	------	------	------

35. Bag A weighs $\frac{2}{3}$ kg. Bag B weighs $\frac{1}{9}$ kg less than Bag A.

Find the total mass of the two bags.

Express your answer as a mixed number in its simplest form.

 kg

Section C (10 x 4m = 40m)

Work out these problem sums carefully. For each sum, show your workings and statements clearly.

36. A group of 9 pupils shared a box of pencils. After they had taken 8 pencils each, there were 3 pencils left. How many pencils were there at first?

37. The tickets for a soccer match are priced at \$9 for an adult ticket and \$4 for a child ticket. How much does Mr Chua have to pay if he takes his wife and 4 children to the soccer match?

38. Jack has twice as many marbles as Paul. Rick has 3 times as many marbles as Jack. If Rick has 32 more marbles than Jack, how many marbles do Paul and Jack have altogether?

39. Danny bought 63 guppies from a pet store. He gave $\frac{5}{9}$ of the guppies to his sister. How many guppies had he left?

40. John and Mei Lin saved \$840 altogether. $\frac{5}{7}$ of the total savings was from John. How much more money did John save than Mei Lin?

41. Jane had $\frac{4}{5}$ m of red ribbon. She used $\frac{1}{10}$ m of red ribbon to tie a present. Then she bought another $\frac{1}{5}$ m of blue ribbon. What was the total length of ribbon she had in the end?

42. Sharon had 236 red beads and 4 times as many blue beads as red beads. She used a total of 168 beads to make a bracelet. How many beads were left?

43. Peter bought a table and 6 chairs for \$1564. The table cost \$815 more than each chair. How much did Peter pay for each chair?

44. The total mass of Alex, James and Richard is 146 kg. Alex is 9 kg heavier than James and 16 kg heavier than Richard. What is Alex's mass?

45. A box of sweets was shared equally among a group of 30 pupils.
5 of them gave all their sweets equally to the rest of the pupils.
As a result, the rest of the pupils received 2 more sweets each.
How many sweets were there in the box?

End of Paper

ANSWER SHEET

EXAM PAPER 2009

SCHOOL : NAN CHIAU PRIMARY
SUBJECT : PRIMARY 4 MATHEMATICS

TERM : SA1

Q1	Q2	Q3	Q4	Q5	Q6	Q7	Q8	Q9	Q10	Q11	Q12	Q13	Q14	Q15
3	3	3	3	2	2	1	2	1	1	3	4	2	2	1

16)2750 17)700 18)88 19) $\frac{3}{4}$ 20)48 21) $\frac{4}{7}$ 22)A 23)3

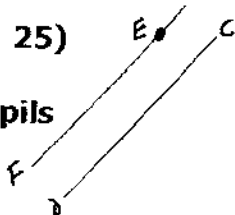
24)JN 25)  26)32m 27)97612 28)30 pupils

29)130 pupils 30) $2\frac{1}{4}$ 31)42cm 32)12cm

33)South-east 34)1819 35) $\frac{12}{9}$

36) $9 \times 8 = 72$
 $72 + 3 = 75$

There were 75 pencils at first.

37) $9 \times 2 = 18$
 $4 \times 4 = 16$
 $18 + 16 = 34$

Mr Chua has to pay \$34

38)4 units \rightarrow 32
 $32 \div 4 = 8$
 $8 \times 3 = 24$

Paul and Jack has 24 marbles altogether.

39) $63 \div 9 = 7$
 $7 \times 5 = 35$
 $63 - 35 = 28$

Danny had left 28 guppies.

40) $840 \div 7 = 120$

$120 \times 5 = 600$

$840 - 600 = 240$

$600 - 240 = 360$

John saved \$360 more than Mei Lin.

41) $4/5 = 8/10$

$1/5 = 2/10$

$8/10 - 1/10 = 7/10$

$7/10 + 2/10 = 9/10$

Jane has $9/10$ m of ribbon in the end.

42) 1 unit \rightarrow 236

5 units \rightarrow $236 \times 5 = 1180$

$1180 - 168 = 1012$

Sharon left 1012 beads.

43) $1564 - 815 = 749$

$749 \div 7 = 107$

Each chair cost \$107.

44) $146 + 9 = 155$

$155 + 16 = 171$

$171 \div 3 = 57$

Alex's mass is 57kg.

45) $2 \times 25 = 50$

$50 \div 5 = 10$

$10 \times 30 = 300$

There were 300 sweets in the box.