



## AI TONG SCHOOL

2009 CONTINUAL ASSESSMENT (1)

PRIMARY SIX SCIENCE

**DURATION : 1hr 45 min**

**DATE: 6<sup>th</sup> March 2009**

### INSTRUCTIONS

**Do not open the booklet until you are told to do so.**

**Follow all instructions.**

**Answer all questions.**

Name : \_\_\_\_\_ ( )

Class : Primary \_\_\_\_\_

Parent's Signature : \_\_\_\_\_

Date : \_\_\_\_\_

MARKS	100
-------	-----

**Section A (30 x 2 marks)**

For each question from 1 to 30, four options are given. One of them is the correct answer. Make your choice (1, 2, 3 or 4). **Shade the correct oval (1, 2, 3 or 4) on the Optical Answer Sheet.**

1. The table below shows a classification of materials.

<b>Group A</b>	<b>Group B</b>
Aluminium foil	Iron rod
Ceramic vase	Stainless steel spoon
Copper coin	Staple
Porcelain cup	Nickel nail

Which one of the following shows the correct headings of Group A and Group B?

(1)	<table border="1"><thead><tr><th><b>Group A</b></th><th><b>Group B</b></th></tr></thead><tbody><tr><td>Non-metals</td><td>Metals</td></tr></tbody></table>	<b>Group A</b>	<b>Group B</b>	Non-metals	Metals
<b>Group A</b>	<b>Group B</b>				
Non-metals	Metals				
(2)	<table border="1"><thead><tr><th><b>Group A</b></th><th><b>Group B</b></th></tr></thead><tbody><tr><td>Non-magnetic Objects</td><td>Magnetic Objects</td></tr></tbody></table>	<b>Group A</b>	<b>Group B</b>	Non-magnetic Objects	Magnetic Objects
<b>Group A</b>	<b>Group B</b>				
Non-magnetic Objects	Magnetic Objects				
(3)	<table border="1"><thead><tr><th><b>Group A</b></th><th><b>Group B</b></th></tr></thead><tbody><tr><td>Insulators of Electricity</td><td>Conductors of Electricity</td></tr></tbody></table>	<b>Group A</b>	<b>Group B</b>	Insulators of Electricity	Conductors of Electricity
<b>Group A</b>	<b>Group B</b>				
Insulators of Electricity	Conductors of Electricity				
(4)	<table border="1"><thead><tr><th><b>Group A</b></th><th><b>Group B</b></th></tr></thead><tbody><tr><td>Good Conductors of Heat</td><td>Poor Conductors of Heat</td></tr></tbody></table>	<b>Group A</b>	<b>Group B</b>	Good Conductors of Heat	Poor Conductors of Heat
<b>Group A</b>	<b>Group B</b>				
Good Conductors of Heat	Poor Conductors of Heat				

2. The classification chart below shows how some animals are grouped.

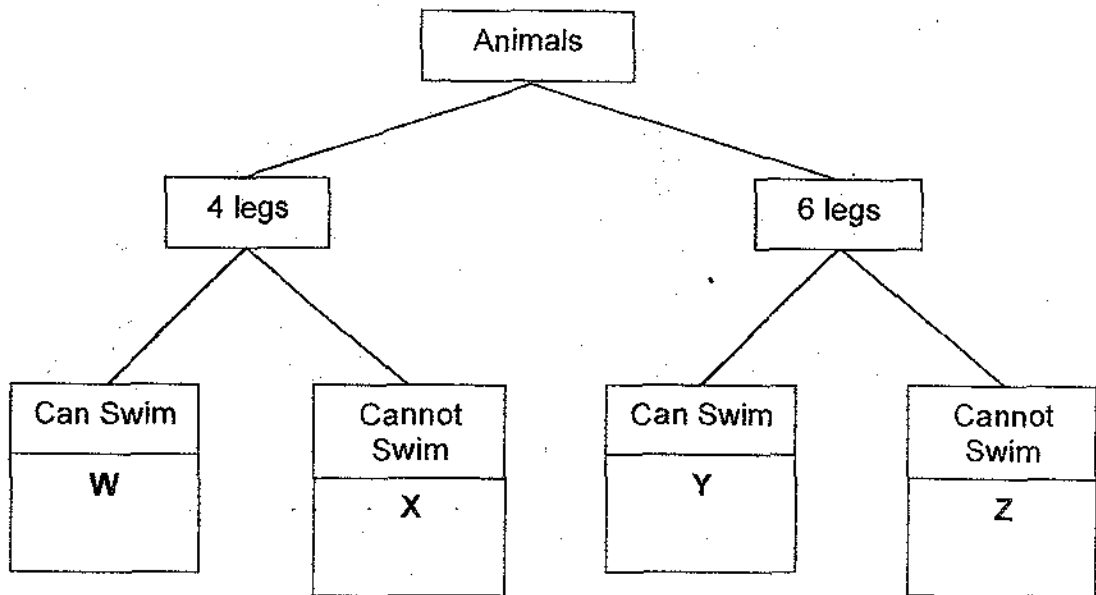

Which of the following animals can X and Z be in the classification chart above?

	X	Z
(1)	Cat	Ant
(2)	Duck	Cockroach
(3)	Squirrel	Dragonfly Nymph
(4)	Mosquito	Frog

3. The diagram shows a tent with parts A, B and C labelled as shown.

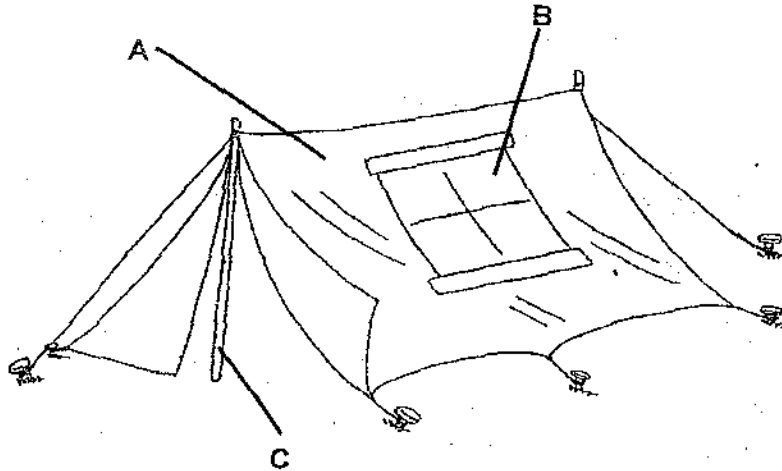

The table below shows materials P, Q and R and their properties.

Material	Properties
P	Transparent and waterproof
Q	Anti-rust, durable and hard
R	Waterproof

Which of the following shows the best material to be used for each labelled part of the tent?

	A	B	C
(1)	P	Q	R
(2)	Q	R	P
(3)	R	P	Q
(4)	P	R	Q

4. Which one of the following organisms feeds on decaying matter?

- (1) Moss
- (2) Algae
- (3) Lizard
- (4) Bacteria

5. The diagram below shows a classification chart.

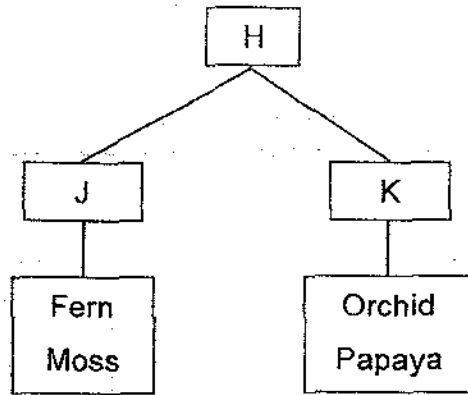

Which one of the following statements about the classification chart above is true?

- (1) H consists of flowering plants only.
- (2) H consists of plants that have chlorophyll.
- (3) K consists of plants that reproduce from suckers.
- (4) J consists of living things that cannot make their own food.

6. Andric saw a flying animal. It feeds on fruits only and has an outer covering of hair. With reference to the classification chart below, which one of the following groups can Andric place the animal in?

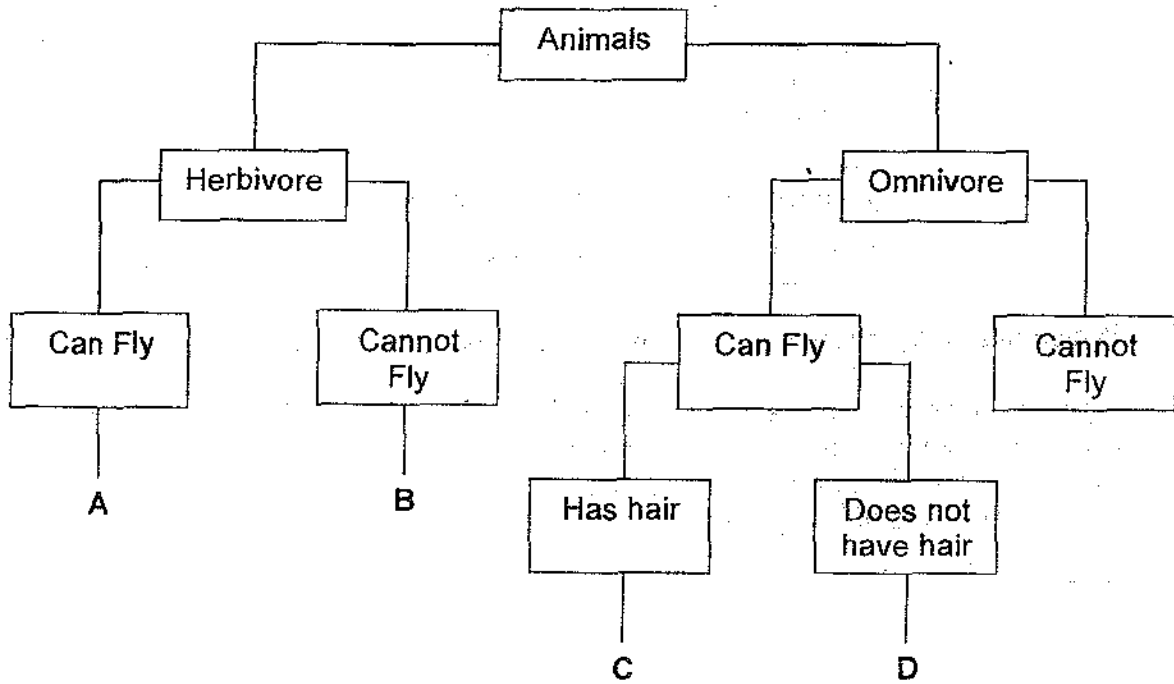

- (1) A
- (2) B
- (3) C
- (4) D

7. The table below shows the properties of two materials, A and B.

A	B
hard	soft
translucent	opaque
breaks easily	flexible

Which one of the following shows the objects that can be made from materials A and B?

	A	B
(1)	mirror	ornaments
(2)	test tube	chopsticks
(3)	windscreen	eraser
(4)	bathroom windows	balloon

8. Which property is taken into consideration for making a water flask?

- (1) thermal property
- (2) electrical property
- (3) magnetic property
- (4) degree of transparency

9. The diagrams below show how 4 ramps are set up.

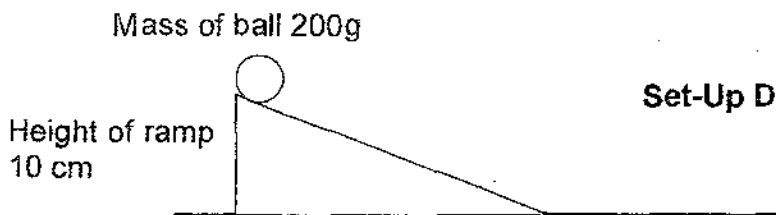
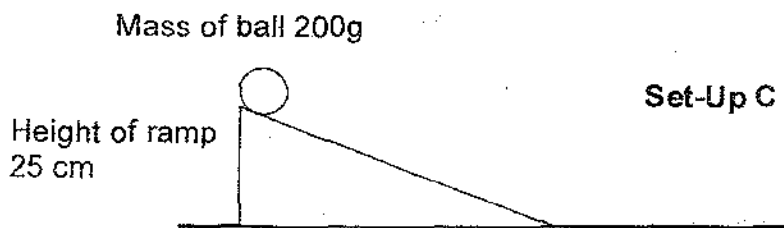
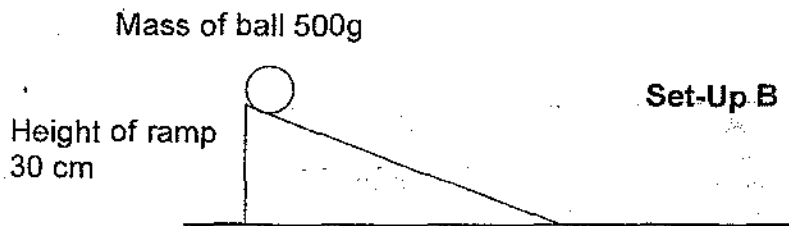
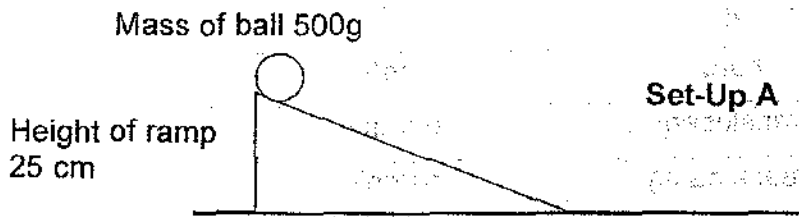

Which 2 set-ups can be used to show the relationship between the mass of the object and amount of kinetic energy?

- (1) Set-up A and C
- (2) Set-up B and C
- (3) Set-up B and D
- (4) Set-up A and D

10. What kind(s) of energy does a moving roller coaster produce?

- A: Sound energy
- B: Heat energy
- C: Electrical energy
- D: Kinetic energy

- (1) A and D only
- (2) B and C only
- (3) A, B and D only
- (4) All of the above

11. Laura recorded the flight time and height of a toy rocket. She then plotted her results in the graph below.

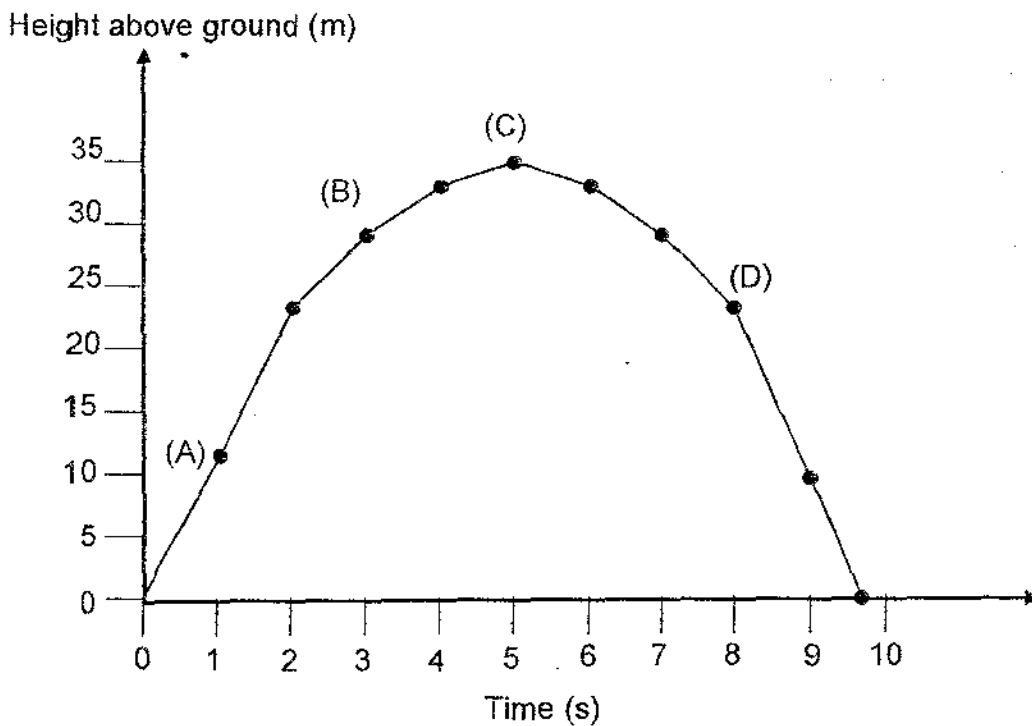

At which point on the graph was kinetic energy the lowest?

- (1) A
- (2) B
- (3) C
- (4) D

12. Study the flowchart below.

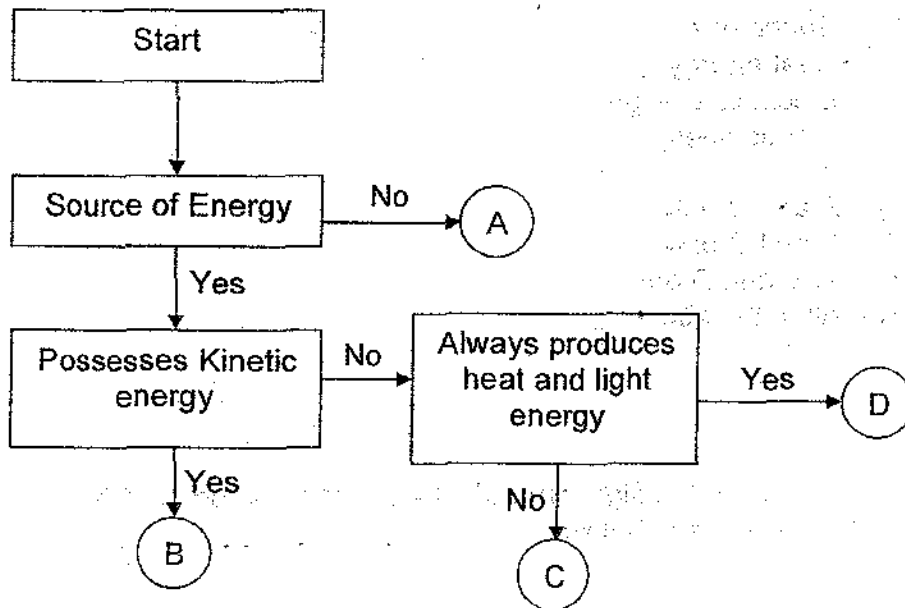

What could B and D represent?

	B	D
(1)	Bouncing Ball	Coal
(2)	Running water	Sun
(3)	Rolling Ball	Oil
(4)	Wind	Moon

13. Fuels and batteries are two different sources of potential energy. In what way are they different?

- (1) Fuels are obtained from plants while batteries are man-made.
- (2) Fuels have chemical energy while batteries have electrical energy.
- (3) The energy in fuels can be destroyed while the energy in the batteries cannot.
- (4) The chemical energy in fuels is changed into heat energy when burnt while that in the batteries is changed to electrical energy in a closed circuit.

14. Jimmy had a toy. He wound it up and placed it in a basin of water. He observed that the length of time his wound-up toy took to move in the water was dependent on the number of times he turned the key.

	Test 1	Test 2	Test 3	Test 4
No. of turns of the key	5 turns	10 turns	15 turns	20 turns
Duration of movement	1 minute	2 minutes	3 minutes	4 minutes

What can you infer from the table?

- (1) A larger key makes the toy move faster.
  - (2) The water affects the length of time the toy moves.
  - (3) The greater the number of turns, the greater the kinetic energy the toy has.
  - (4) The faster Jimmy winds up the toy, the greater the potential energy the toy has.
15. Kendra arranged four rods as shown in the figure below and stretched four identical kinds of rubber bands W, X, Y and Z on them.

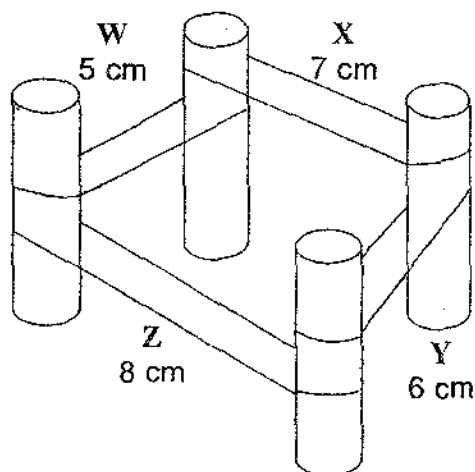

Which rubber band has the most elastic potential energy?

- (1) W
- (2) X
- (3) Y
- (4) Z

16. Which energy conversion below best describes a hammer knocking a nail into a wooden plank?

- (1) Kinetic energy (hammer)  $\rightarrow$  kinetic energy (nail) + heat energy + sound energy
- (2) Kinetic energy (nail)  $\rightarrow$  kinetic energy (hammer) + heat energy + sound energy
- (3) Kinetic energy (hammer)  $\rightarrow$  kinetic energy (nail)  $\rightarrow$  heat energy  $\rightarrow$  sound energy
- (4) Kinetic energy (nail)  $\rightarrow$  kinetic energy (hammer)  $\rightarrow$  heat energy  $\rightarrow$  sound energy

17. A cyclist rode his bicycle up a hill. He had difficulty cycling as he went higher. Which of the following force(s) was/were slowing him down?

- A: Gravity
- B: Friction
- C: Elasticity

- (1) A only
- (2) B only
- (3) A and B only
- (4) A and C only

18. Which of the following statements show the effects of forces?

- A: Writing on the whiteboard.
- B: A moving car slows down when the brakes are applied.
- C: An astronaut floats outside the spacecraft.
- D: A boy stretching a rubber band between his two fingers.

- (1) A and B only
- (2) A, B and C only
- (3) A, B and D only
- (4) A, B, C and D

19. Kenny set up an experiment as shown below.

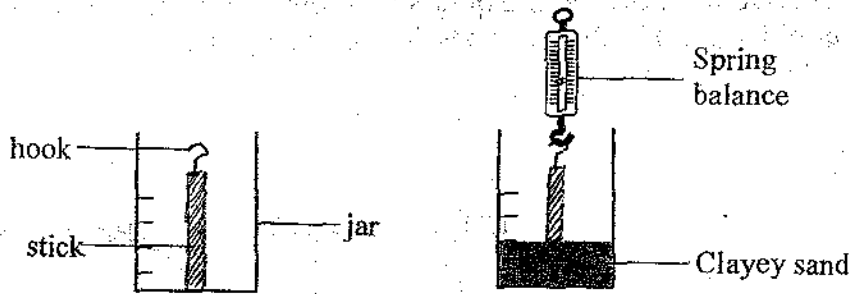

He placed a stick in a jar and filled the jar with clayey sand to the second marking. Then, he attached a spring balance to the stick and pulled it out slowly. He recorded the amount of force needed to pull the stick out of the clayey sand. Next, he repeated the experiment with more sand reaching different marks each time.

After the experiment, he plotted a graph to show the relationship between the force needed to pull the stick out to the area just above the clayey sand. Which one of the following graphs is correct?

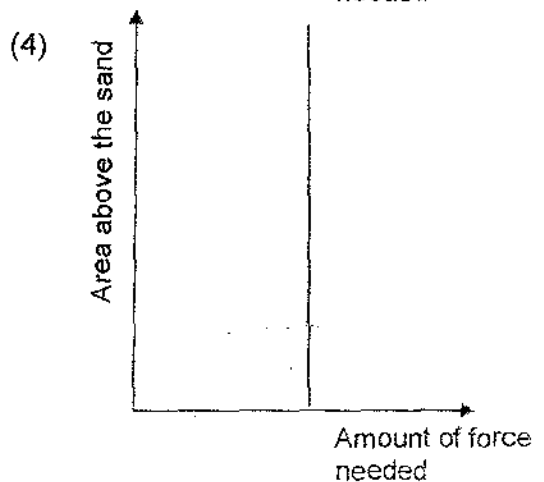
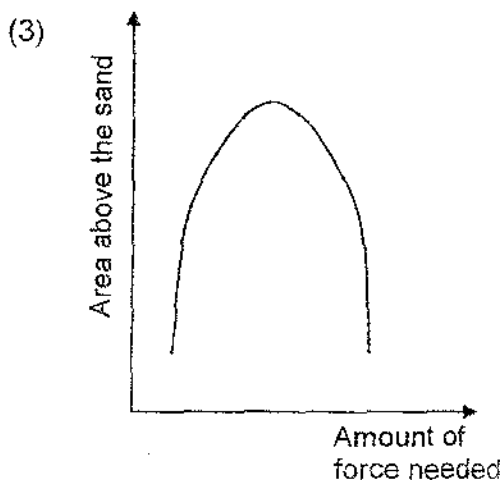
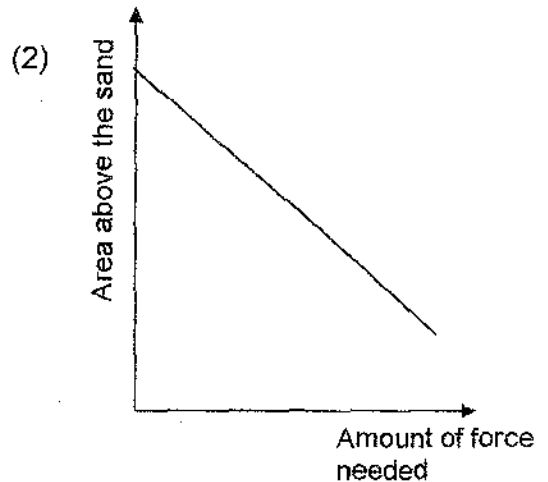
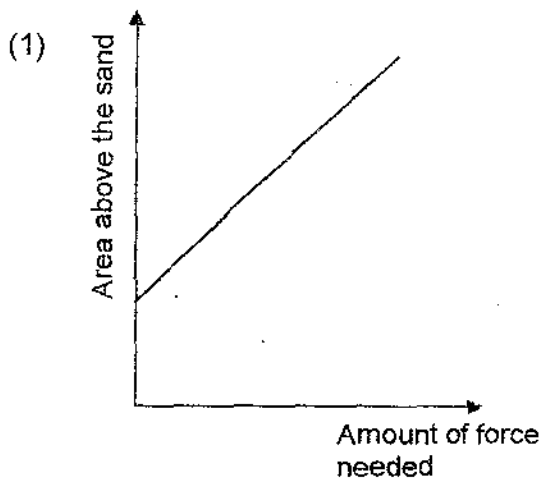

20. 3 objects, A, B and C were brought one at a time very near to a magnet suspended as shown in the diagram below. Each object was brought to the bar magnet twice with different ends facing the magnet.

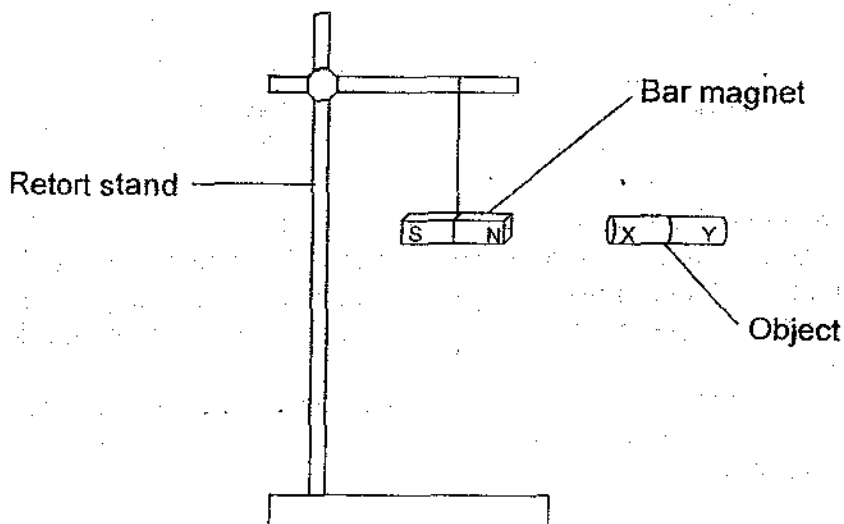

The table below shows the result of the experiment.

Object	End	Attracted to the magnet	Repelled by the magnet
A	X	No	No
	Y	No	No
B	X	No	Yes
	Y	Yes	No
C	X	Yes	No
	Y	Yes	No

Which of the following statements is **correct**?

- (1) Object A is made of steel.
- (2) Object B and C are magnet.
- (3) End X of Object B is the north pole.
- (4) End Y of Object C is the north pole.

21. Two identical blocks of wood were pushed with an equal force across two different surfaces as shown below. The surfaces were covered with materials Q and R respectively.

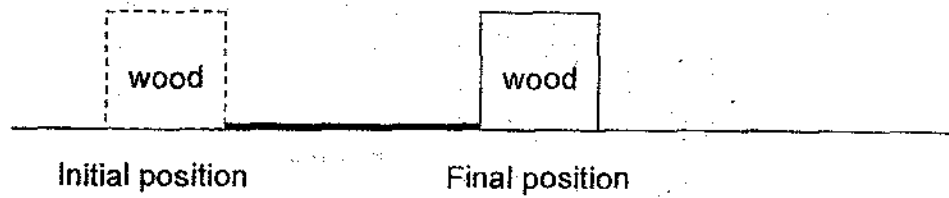

The distance moved by each block of wood on the two surfaces wrapped in materials Q and R were recorded in the table below.

	Distance moved		
	1 <sup>st</sup> try	2 <sup>nd</sup> try	3 <sup>rd</sup> try
On material Q	10 cm	9 cm	15 cm
On material R	14 cm	10 cm	18 cm

Which of the following could materials Q and R be?

	Material Q	Material R
(1)	Cotton	Sandpaper
(2)	Silk	Marble
(3)	Silk	Cotton
(4)	Sandpaper	Marble

22. Majid set up a combined pulley system shown below to help him lift the load. He discovered that this system had 2 advantages.

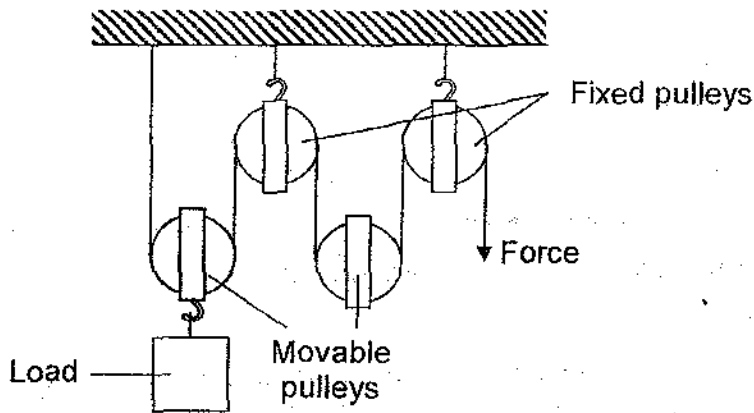

What are the advantages?

- A: The mass of the load is reduced.
- B: The direction of force is changed.
- C: A smaller force is required to lift the load.
- D: The force moves a shorter distance than the load.

- (1) A and D only
- (2) A and C only
- (3) B and C only
- (4) C and D only

23. As shown in the diagram below, the leaves of some plants unfold during sunrise and fold up during sunset.

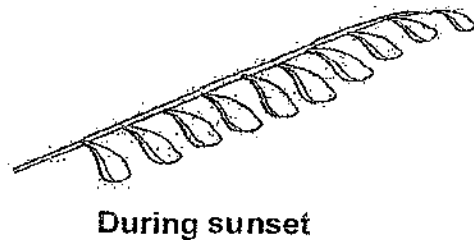
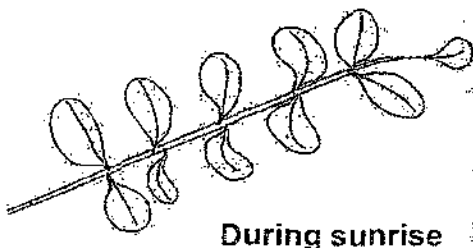

This folding and unfolding of the leaves is related to the \_\_\_\_\_.

- (1) rotation of the Earth about its own axis
- (2) rotation of the Moon about its own axis
- (3) revolution of the Earth around the Sun
- (4) revolution of the Moon around the Earth

24. Substance X has to pass through different parts of a plant cell before reaching the nucleus. Which of the following shows the correct order of the parts passed through by substance X?

- (1) Cell wall, cytoplasm, chloroplast
- (2) Cell wall, cell membrane, cytoplasm
- (3) Cell membrane, cell wall, cytoplasm
- (4) Cell membrane, chloroplast, cytoplasm

25. A single-cell organism, P, divides to form two cells after one cell division as shown below.

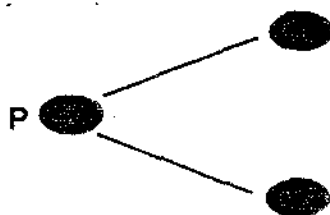

How many of organism P would there be after six cell divisions?

- (1) 16
- (2) 32
- (3) 48
- (4) 64

26. The diagram below shows the Sim family tree.

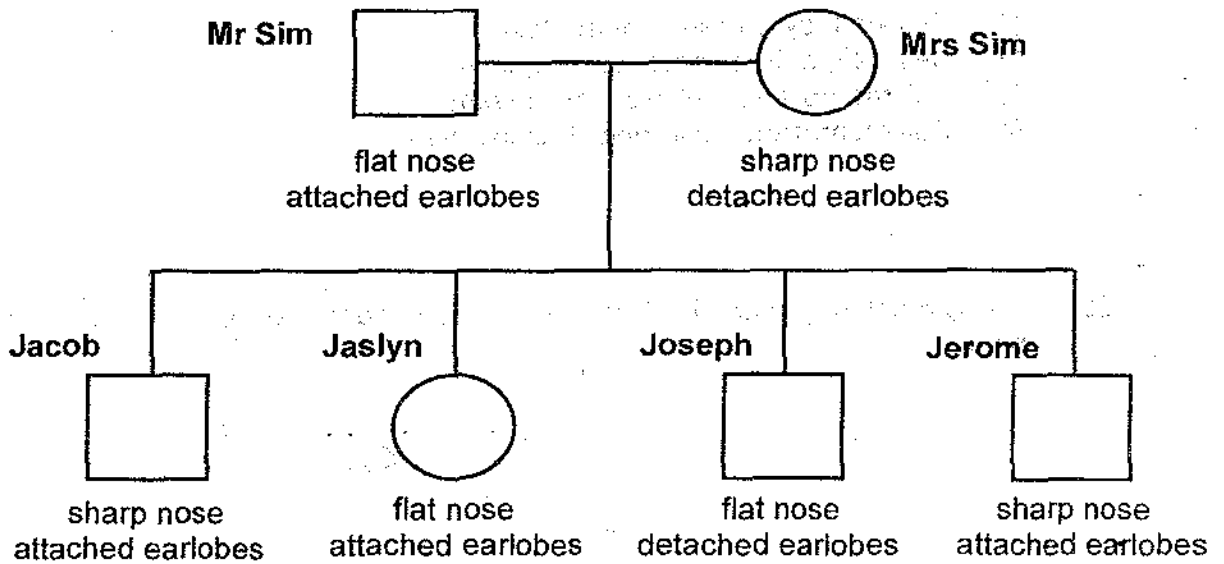

Which of the children inherited **only** one feature from each parent?

- A Jacob
- B Jaslyn
- C - Joseph
- D Jerome

- (1) B only
- (2) A and D only
- (3) B and C only
- (4) A, C and D only

27. Which of the following shows the correct sequence of a flowering plant in one cycle?

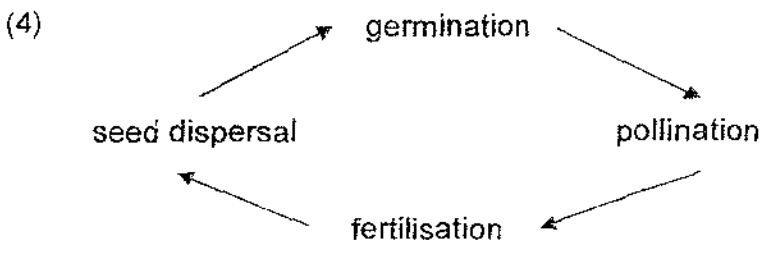
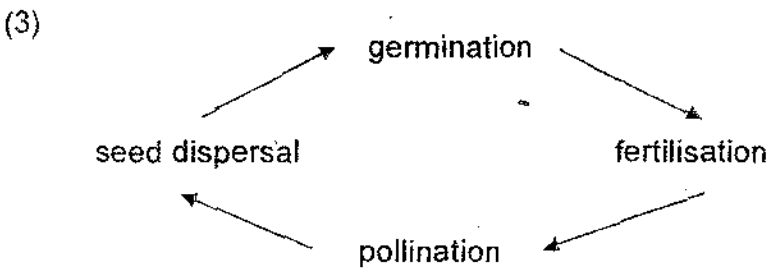
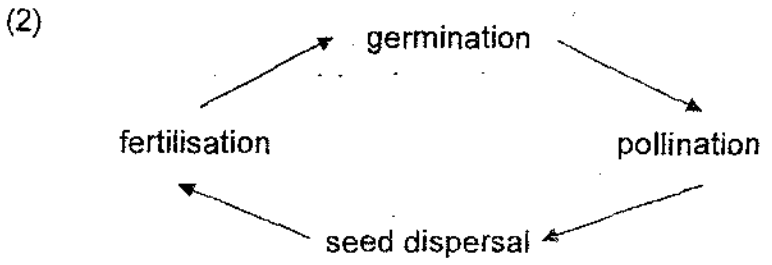
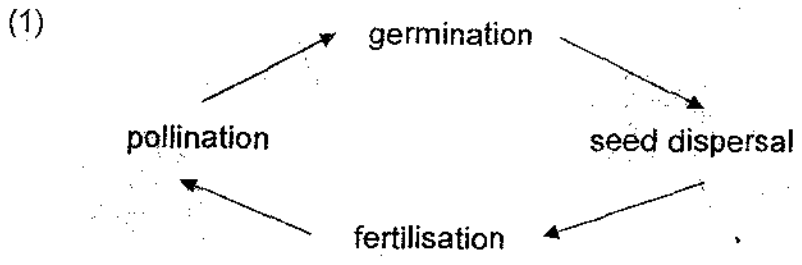

28. The diagrams below show the female and male reproductive systems respectively.

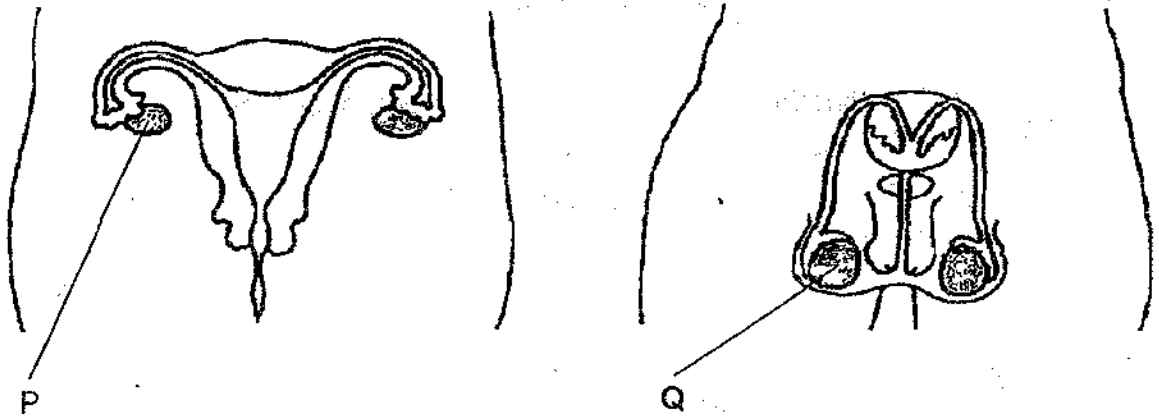

Which of the following shows the functions of the labelled parts correctly?

	P	Q
(1)	Receives sperms	Produce sperms
(2)	Receives sperms	Transports sperms out of the body
(3)	Produce eggs	Produce sperms
(4)	Produce eggs	Transports sperms out of the body

29. The diagram below shows Leaf Z with some young plants growing from its edges.

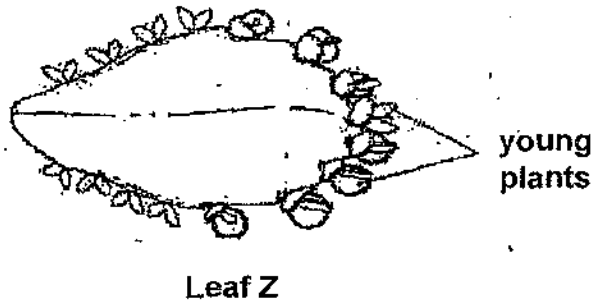

Which one of the following statements is true?

- (1) The young plants reproduce from spores.
  - (2) The young plants reproduce from suckers.
  - (3) Leaf Z must be fertilised before it can produce young plants.
  - (4) The young plants have identical characteristics as the mother plant.
30. There are six living things in a community as shown in the diagram below.

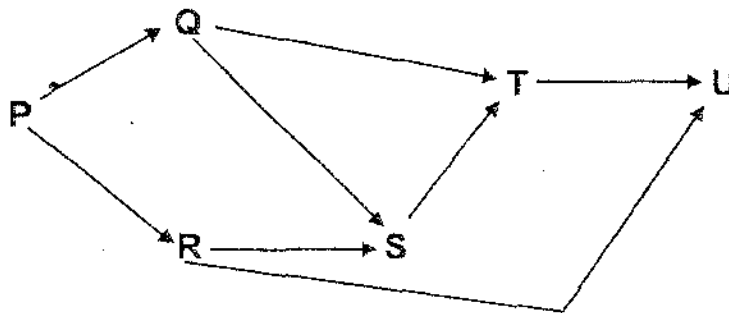

Which organism(s) in the diagram feed(s) on plants only?

- (1) P only
- (2) Q and R only
- (3) S and T only
- (4) S, T and U only

Name: \_\_\_\_\_ ( )  
 Class: P6 ( )

**Section B: 40 marks**

Read the questions carefully and write down your answers in the spaces provided.

31. The chart below shows how eight animals are classified.

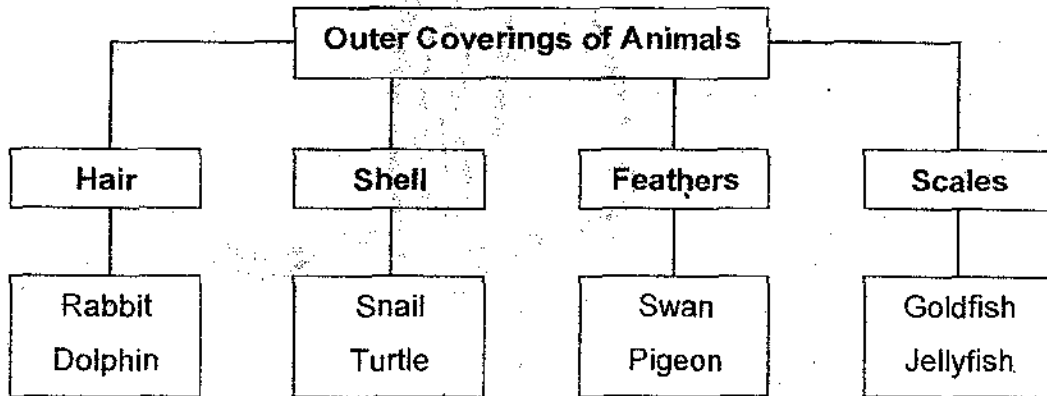

(a) Which animal in the chart above has been **wrongly** classified? [1]

\_\_\_\_\_

(b) Classify the animals in another way using the table provided below. [2]  
 Give the appropriate headings for the classifications you have made.

Animals	
_____	_____

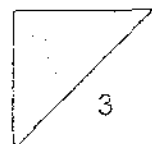

32. The diagram below shows an electric iron.

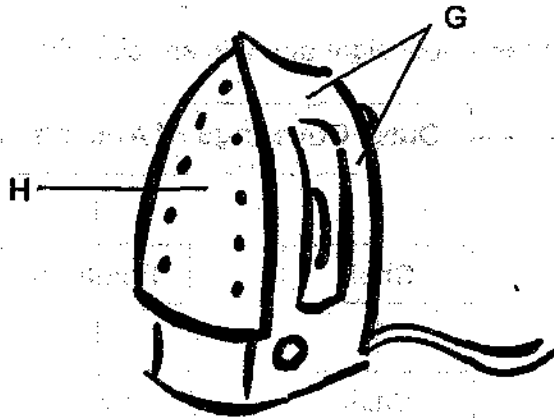

(a) What is a suitable material to make Part G of the electric iron? [1]

---

(b) State one property of the material used to make Part H. [1]

---

---

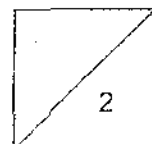

33. Jane read about some organisms and constructed a flow chart as shown below.

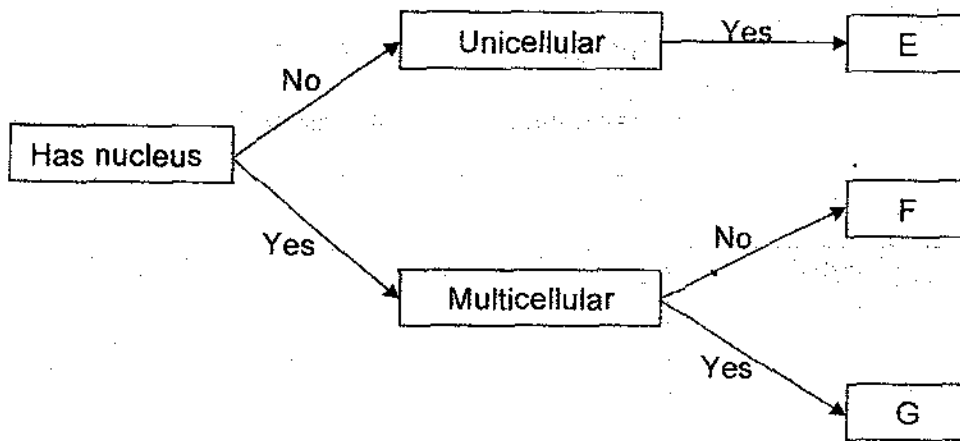

(a) State two characteristics of Organism G.

[1]

---

---

(b) Identify a similarity between Organism E and Organism F.

[1]

---

(c) Suggest an organism that could be Organism F.

[1]

---

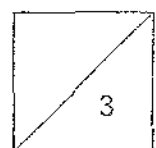

34(a). Classify the plants into three groups A, B and C.

[2]

heliconia	apple
water chestnut	banana plant

Group A	Group B	Group C

(b) How are the plants classified?

[1]

---

---

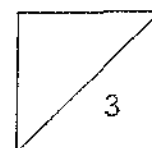

35. Put a tick (✓) in the box to indicate if the following statements are 'True' or 'False'. [2]

	Statement	True	False
(a)	Conductors of heat are also conductors of electricity.		
(b)	Some non-metals are magnetic.		
(c)	Electrical insulators prevent electricity from flowing through.		
(d)	Transparent objects allow only some light to pass through.		

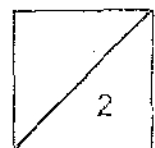

36. A boy moved his toy car backwards a few times before releasing it. Upon releasing the car, it moved forward.

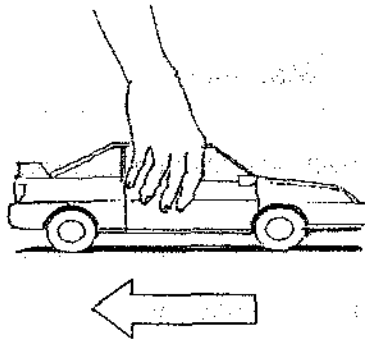

(a) What is the reason for moving the toy car backward a few times? [1]

---

---

(b) Explain how the toy car got the energy to move forward. [1]

---

---

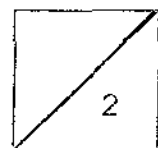

37. Serene threw a 2kg ball from 4 different levels of a building onto a sand pit below. Each time the ball landed on the sand pit, a depression was formed.

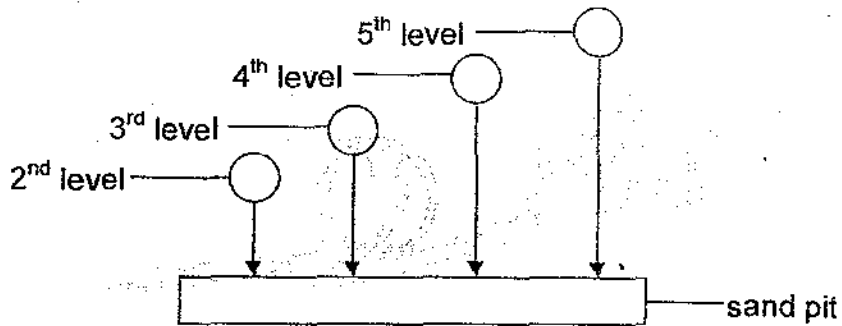

- (a) What form of energy does the ball possess before it is dropped? [1]
- 
- (b) Which level was the ball dropped from to form the deepest depression? [2]  
Explain your answer.
- 
- 
- 

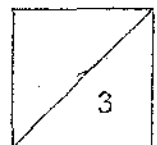

38. Ryan set up an experiment as shown below. To make a ramp, he rested one end of the looping track against a stack of books. He then released a marble from Point X of the track.

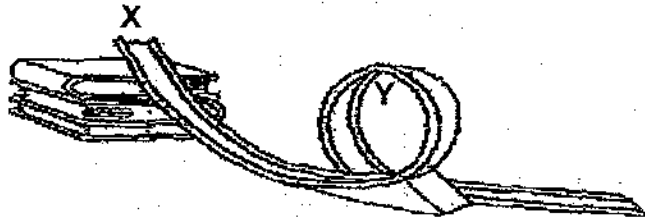

- (a) Ryan observed that the marble rolled along the track and rolled backwards without reaching Point Y. Explain why this happened. [1]

---

---

- (b) Suggest a way to change the setup so that the marble would go all round the loop. [1]

---

---

- (c) Explain your answer in (b) [1]

---

---

---

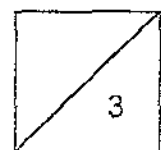

39. A group of girls carried out an activity to find out how long it would take for a pendulum to swing from A to B and back to A again. They repeated the experiment with strings of different lengths and bobs of different masses...

The table below shows the results of their experiment.

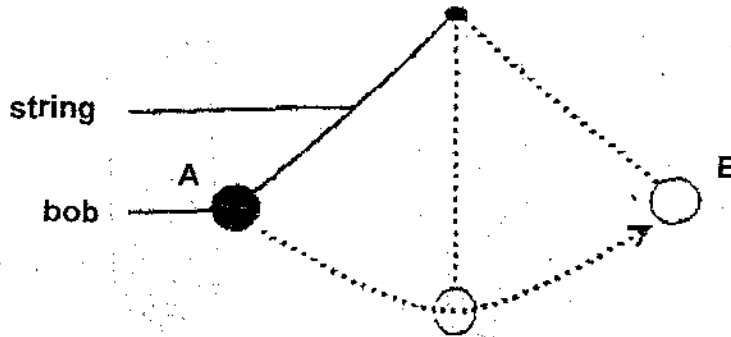

Length of string (cm)	Time taken to complete 10 swings (s)		
	Mass of bob 50g	Mass of bob 200g	Mass of bob 250g
32	11.3	11.3	11.3
70	15.8	15.8	15.8
105	19.7	19.7	19.7

- (a) What affects the speed at which the pendulum swings? [1]

---



---

- (b) What must be done so that the pendulum completes 10 swings in less than 11.3 seconds? [1]

---



---

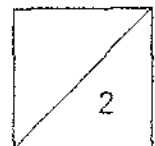

40. Sammy and James went to the amusement park and played on a pin ball machine. The drawing below shows the extent to which each of them pulls the striker.

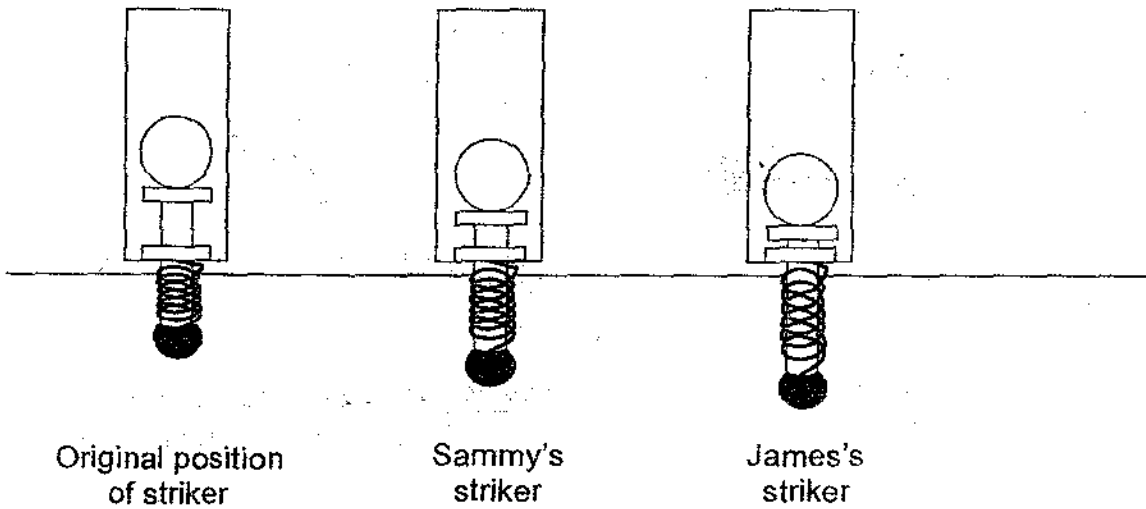

- (a) Whose ball will move faster? [1]

---

- (b) Explain your answer in (a). [1]

---

---

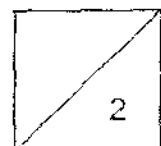

41. A glass block was made to move over 4 similar tiles coated with anti-skid substance V, W, X and Y.

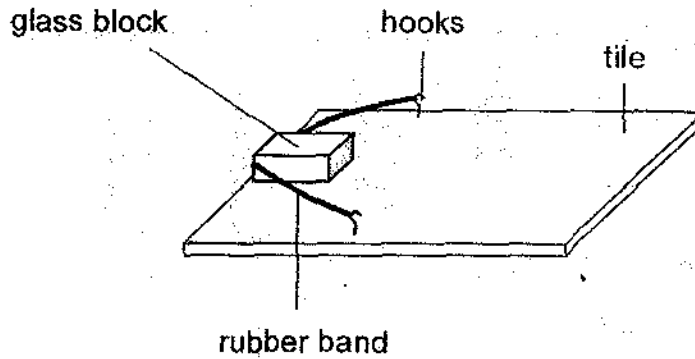

Anti-skid substance	Distance moved by the glass block (cm)	
	Trial 1	Trial 2
V	14	15
W	24	24
X	33	32
Y	45	40

- (a) Which anti-skid substance would be the most effective in preventing slipping? [1]

---

- (b) How did you come to your conclusion? [1]

---



---

- (c) Why was the experiment carried out twice? [1]

---

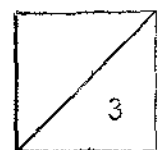

42. Nathan conducted the experiment below to find out how the mass of various weights can affect the extension of the spring.

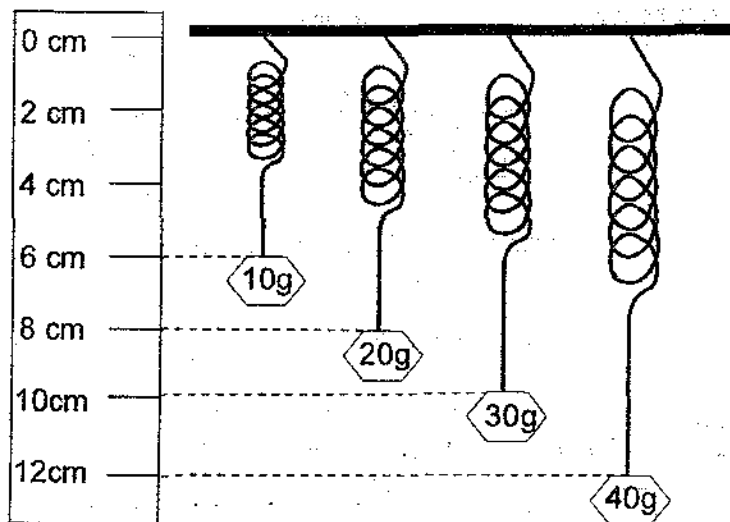

- (a) What was the original length of the spring? [1]

---

- (b) What would the extension of the spring be when a mass of 80g is attached? [1]

---

- (c) State one variable that has to be kept the same in the experiment. [1]

---

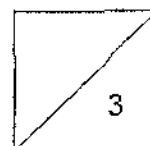

43. The diagram below shows part of an island where two types of plants Y and Z are found growing.

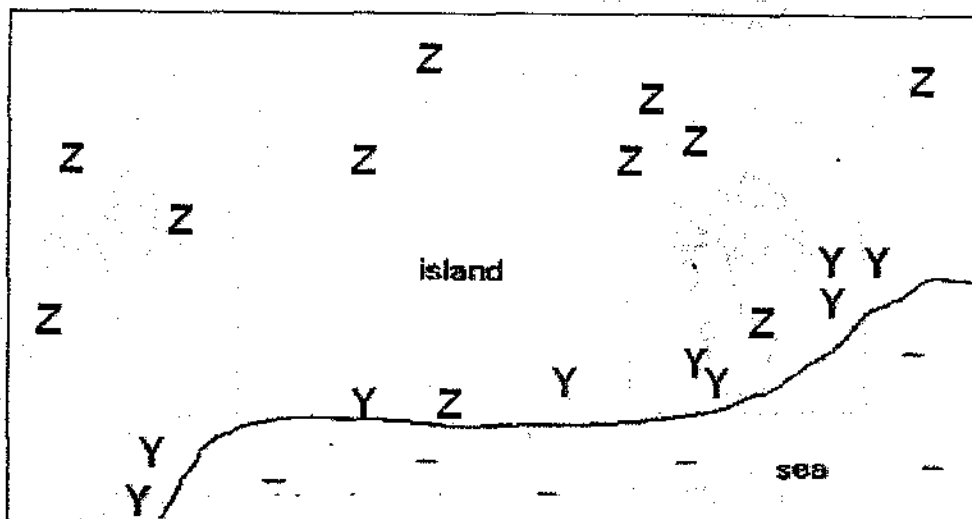

- (a) State the methods of dispersal for plants Y and Z. [1]

(i) Y: \_\_\_\_\_

(ii) Z: \_\_\_\_\_

- (b) Give a reason to your answer to (a) (i). [1]

\_\_\_\_\_  
\_\_\_\_\_

- (c) Name one characteristic of the fruit of plant Y. [1]

\_\_\_\_\_

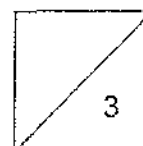

44. Benjamin used the two set-ups below for an experiment. He left the two set-ups in the sun for a few hours.

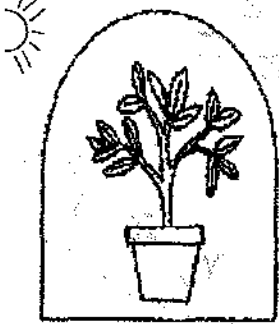
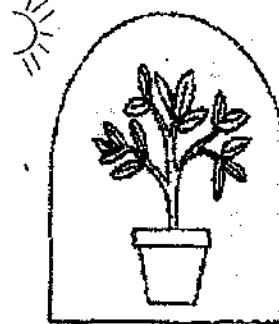
Plant K	Plant L
	
Placed in a glass jar.	Placed in a glass jar covered with black paper.

- (a) What was Benjamin's aim for the experiment? [1]

---

---

- (b) If Benjamin conducted an iodine test on Plant K, what would be the colour of the drop of iodine on the leaf of Plant K? [1]

---

---

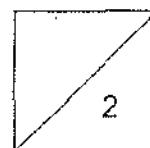

45. Study the diagrams below.

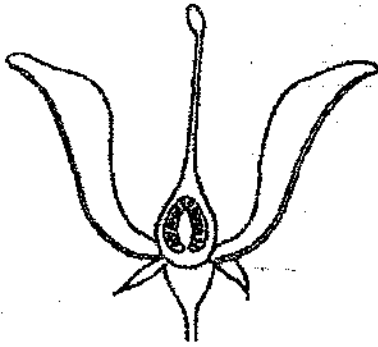

Flower A

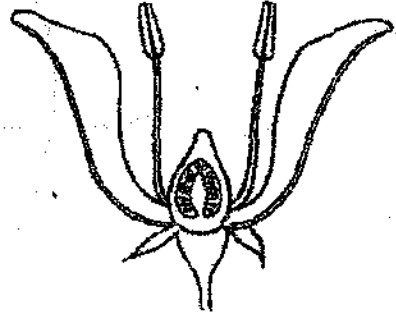

Flower B

Explain how pollination can take place between the two flowers.

[2]

---

---

---

---

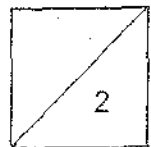

46. The diagram below shows Cell W.

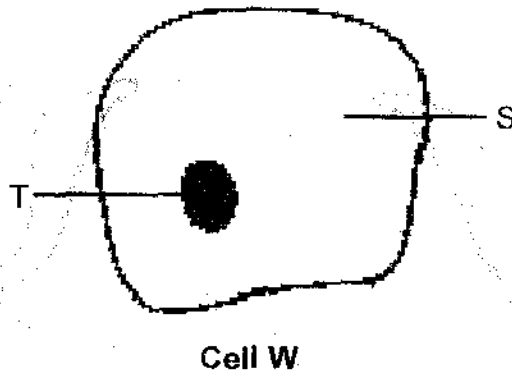

(a) Is Cell W a plant cell or an animal cell? Explain your answer. [1]

---

---

(b) What is the function of Part S? [1]

---

---

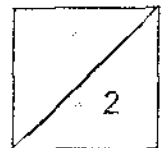

-- End of Paper --

# ANSWER SHEET

EXAM PAPER 2008

SCHOOL : AITONG PRIMARY SCHOOL  
SUBJECT : PRIMARY 6 SCIENCE

TERM : CA 1

Q1	Q2	Q3	Q4	Q5	Q6	Q7	Q8	Q9	Q10	Q11	Q12	Q13	Q14	Q15	Q16	Q17
2	1	3	4	2	1	4	1	1	3	3	2	4	3	4	1	1

Q18	Q19	Q20	Q21	Q22	Q23	Q24	Q25	Q26	Q27	Q28	Q29	Q30
3	1	3	4	3	1	2	4	4	4	3	4	2

31)a) Jellyfish

b) Can fly: Swan, Pigeon

cannot fly: Rabbit, Dolphin, Snail, Turtle, Goldfish, Jellyfish

32)a) The material is plastic.

b) Part H is a good conductor of electricity.

33)a) Organism G has a nucleus and is multicellular.

b) Organisms E and organisms F are both unicellular.

c) The organism is Yeast.

34)a) A: heliconia, banana plant    B: Water chestnut    C: apple

b) The plants are classified by the way they reproduced.

35)a) F    b) F    c) T    d) F

36)a) To build up more potential energy./To wind up the spring in the toy car so that it has more potential energy.

b) It got the energy by moving back ward, thus letting it gain potential energy.

**37) a) Gravitational potential energy.**

**b) The 5<sup>th</sup> level. When the ball is at the highest point, the most Gravitational potential energy it has, thus more kinetic energy is changed.**

**38) a) It did not have enough kinetic energy to go all the way up to the top of the loop as it did not enough gravitational potential energy.**

**b) Stack up more books and make the height of the books more higher.**

**c) By putting more books, the marble will have more gravitational potential energy to change to more kinetic for the marble to go round the loop.**

**39) a) The length of the swing.**

**b) Shorten the string to 32cm.**

**40) a) James's ball will move faster.**

**b) The longer the spring is stretched, the more elastic potential energy it has and the faster the ball would move.**

**41) a) Anti-skid substance V.**

**b) The distance moved by the glass block was the least which shows that there was the most friction in anti-skid substance.**

**c) This is as it more accurate.**

**42) a) 4cm**

**b) 16cm**

**c) It must be the same type of spring.**

**43) a) Y: By water      Z: By animals**

**b) Plant Y is dispersed by water, thus the water would cause the plant to land on the shore of the sea.**

**c) It has fibrous husk to make it float on the water.**

**44)a) Benjamin wanted to see if the plants needed sunlight to photosynthesize.**

**b) The colour will be dark blue.**

**45) The pollen grains from the anther of flower B are carried by the wind.**

**46)a) It is an animal cell. Cell W does not have cell wall and chloroplast.**

**b) It is to allow the movement within the cell.**

**---end---**