



PEI HWA PRESBYTERIAN PRIMARY SCHOOL
FIRST CONTINUAL ASSESSMENT 2009
SCIENCE
PRIMARY 6

Name : _____ ()

Class : _____ (6)

Date : _____

Parent's Signature : _____

BOOKLET A

Total time for Booklets A and B : 1 hour 45 minutes

Booklet	Type	Max. Marks	Marks Obtained
A	Multiple-Choice	60	
B	Structured Questions	40	
Grand Total		100	

- Do not open this booklet until you are told to do so.
- Follow all instructions carefully.
- Answer all questions.
- Check your work carefully.

Section A : Multiple-Choice Questions (60 marks)

For each question from 1 to 30, four options are given. One of them is the correct answer. Make your choice (1,2,3 or 4). Shade the correct oval (1,2,3 or 4) on the Optical Answer Sheet.

- 1 The following table gives information on four plants P, Q, R, S. A '✓' shows that the plant has the characteristic.

Characteristic	Plant P	Plant Q	Plant R	Plant S
Bears flowers		✓	✓	
Grows in water	✓			✓

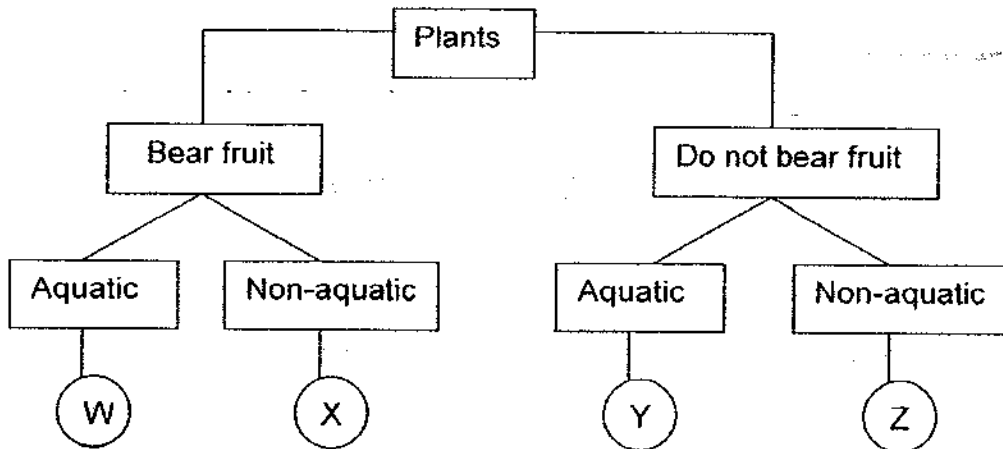

From the information stated, where do plants P and R belong in the classification chart?

	Plant P	Plant R
(1)	Y	W
(2)	Z	X
(3)	W ✓	Y ✓
(4)	Y	X

- 2 Tommy wants to find out the effect of overcrowding on the growth of a plant. Which sets should he set up to carry out a fair test?

Set	Number of seeds	Type of soil	Size of pot
A	20	Garden	Large
B	10	Garden	Small
C	10	Loamy	Medium
D	10	Garden	Medium
E	10	Garden	Large
F	5	Loamy	Small

- (1) A, B and D only
 (2) A, C and F only
 (3) C, E and F only
 (4) B, D and E only

- 3 Study the set-up below.

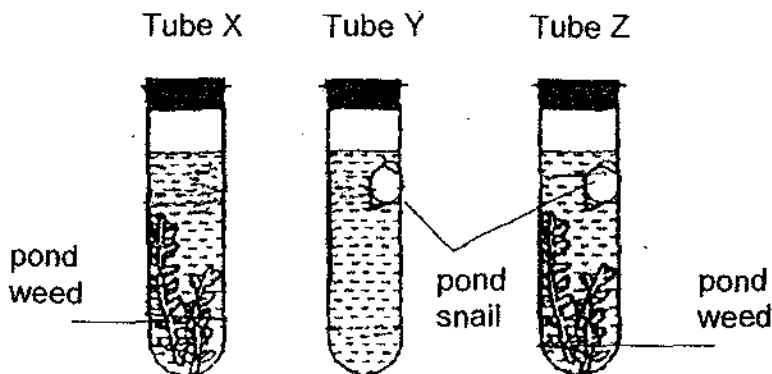

Three tubes X, Y and Z are filled with equal amounts of pond water and placed under the sun. After a few hours, what may be the level of dissolved carbon dioxide in the water of the three tubes?

	Tube X	Tube Y	Tube Z
(1)	Increase	Increase	Decrease
(2)	Unable to tell	Decrease	Increase
(3)	Decrease	Increase	Unable to tell
(4)	Decrease	Unable to tell	Unable to tell

- 4 The family tree below shows the traits each child inherits from his/her parents.

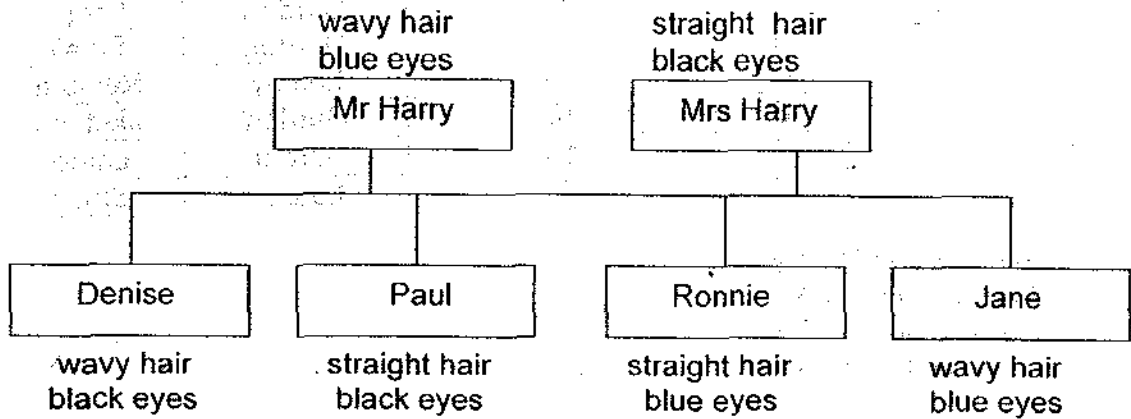

Which child most resembles the father?

- (1) Paul
- (2) Jane
- (3) Denise
- (4) Ronnie

- 5 Reproduction of cells takes place all the time to _____.

- A prevent cells from dying
- B replace old and damaged cells
- C increase the size and number of cells

- (1) A only
- (2) B only
- (3) B and C only
- (4) A and C only

6 Teck Wah's mother bought a plant. A few months later, she noticed that the leaves were dropping and the plant looked like it was dying. What could be the possible reasons for this?

- A The plant did not get enough sunlight.
- B The roots of the plant were not strong enough.
- C She watered the plant with too much water and too often.
- D The nutrient solution she used on the plant was too concentrated.

- (1) A, B and C only
- (2) A, B and D only
- (3) A, C and D only
- (4) B, C and D only

7 Identical twins are formed when a fertilized egg splits into two separate cells. The diagrams below trace the stages of this process. Which one of the following diagrams best represents the formation of identical twins?

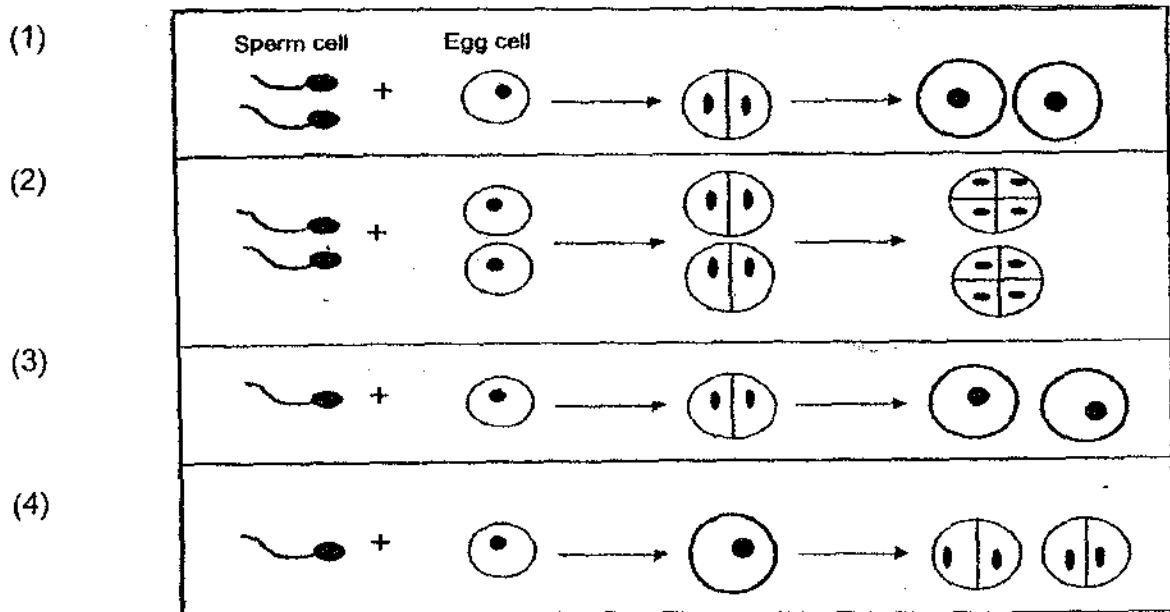

9 The figure below shows a simplified way of how blood travels in the body.

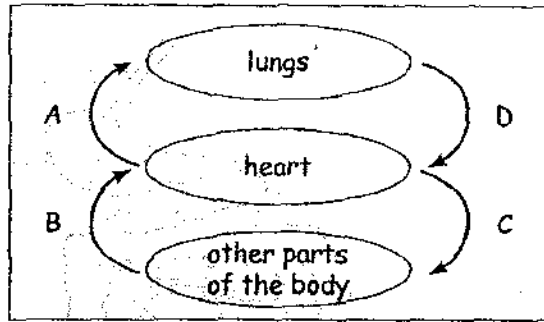

The bar chart shows the amount of oxygen in 4 blood samples, W, X, Y and Z taken at the same time from different blood vessels, A, B, C and D as shown in the figure above.

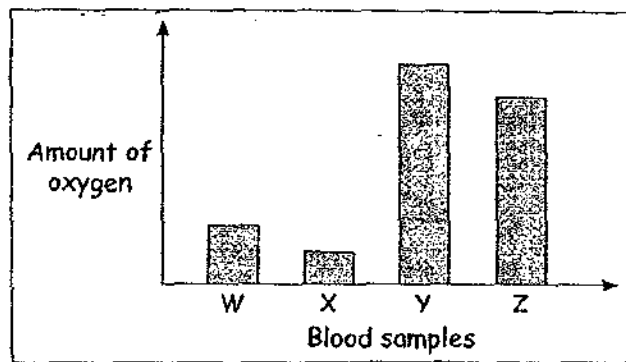

The blood sample that matches blood vessel D is _____.

- (1) W
- (2) X
- (3) Y
- (4) Z

10 The diagram below shows the human digestive system.

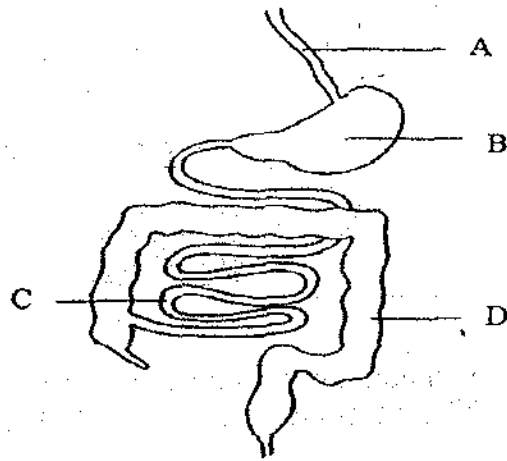

In which part A, B, C or D will digestion not take place?

- (1) A
- (2) B
- (3) C
- (4) D

11 Look at the diagram below.

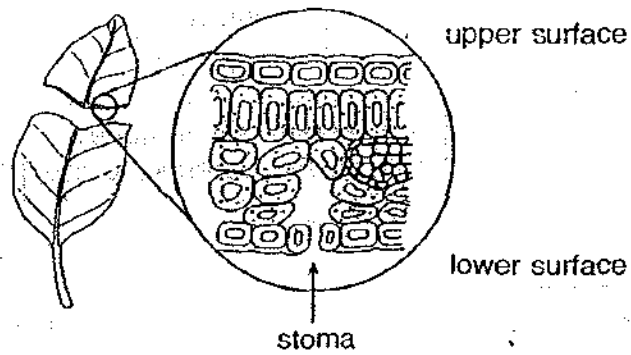

The functions of stoma are to _____

- A allow exchange of gases
- B allow excess water to leave the plant
- C provides chlorophyll for photosynthesis
- D trap light energy so that the plant can make food

- (1) A and B only
- (2) B and C only
- (3) A, B and C only
- (4) B, C and D only

12 Study the classification table below.

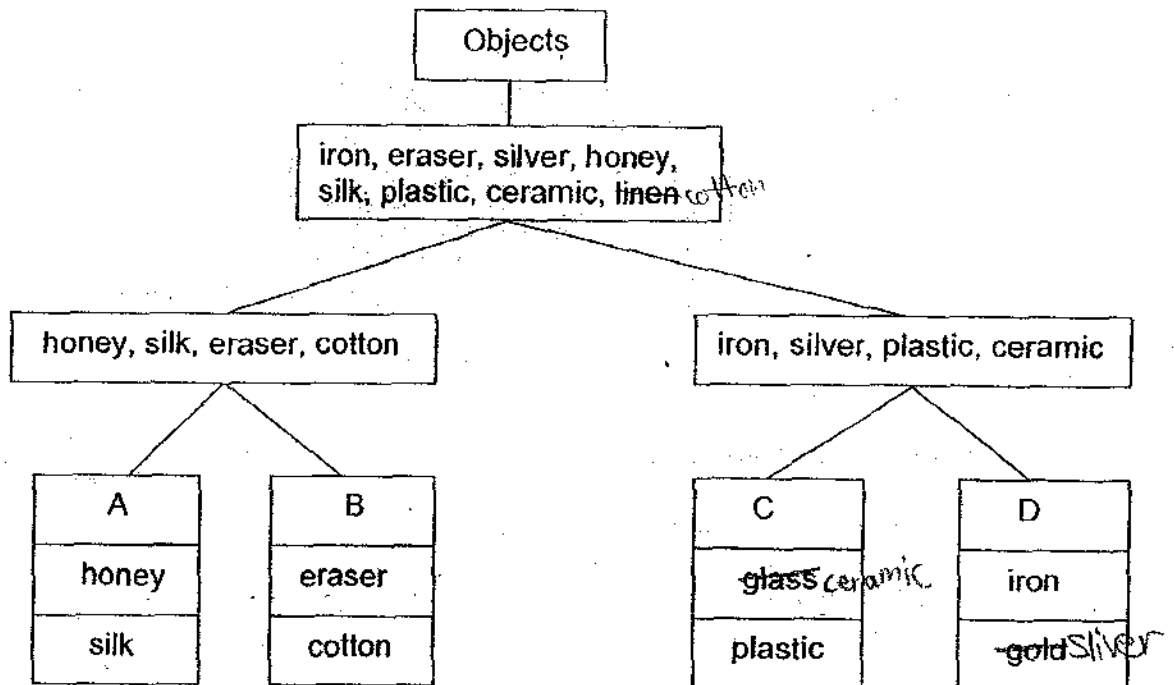

In which group would you put 'wood'?

- (1) A
- (2) B
- (3) C
- (4) D

13 Study the information below.

A	B
cling wrap	ceramics
clothes	copper
spring	brass

Choose suitable headings for the blanks marked 'A' and 'B'.

	A	B
(1)	Translucent	Opaque
(2)	Insulators of Heat	Conductors of Heat
(3)	Plastics	Metals
(4)	Objects	Materials

- 14 The diagrams below show objects A and B when they are placed in containers of water and oil respectively.

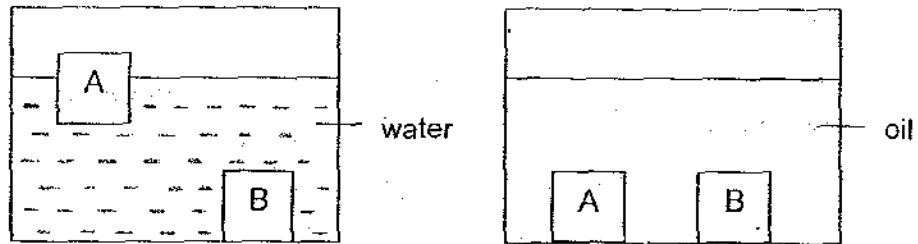

Oil floats on water. Which one of the following shows what happens when objects A and B are placed in a container containing both oil and water?

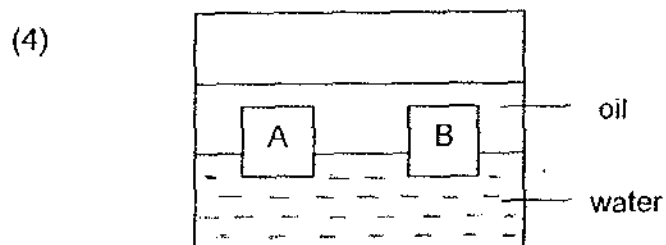
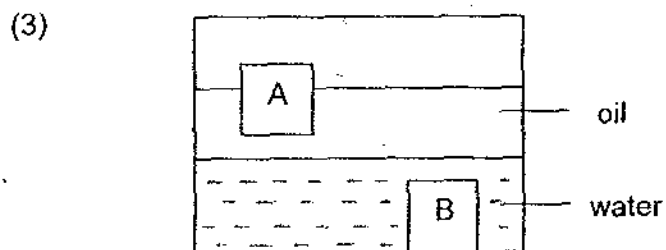
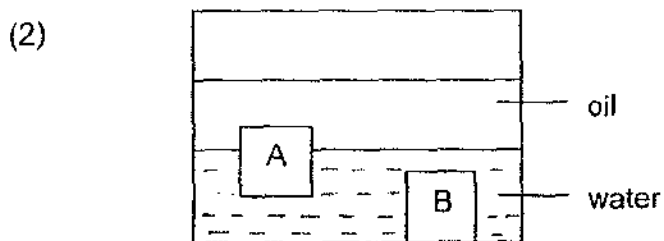
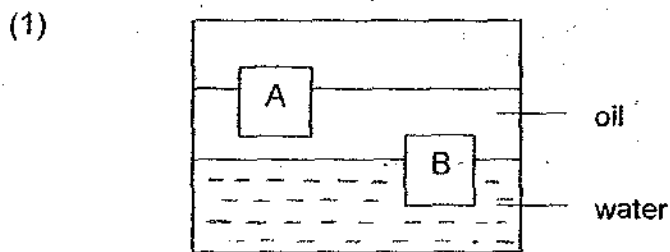

- 15 Four similar magnets were placed in four boxes made of different materials P, Q, R, S, each of the same size and thickness.

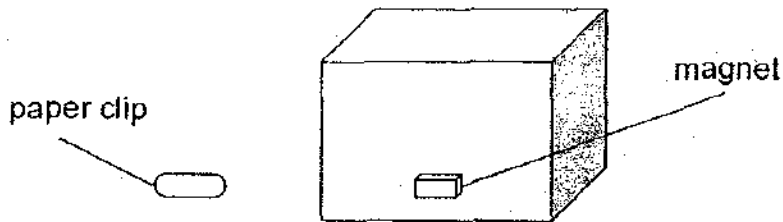

When a paper clip was placed 3cm from each box, the observations were recorded in the table below.

Box	Did the paper clip move towards the box?
P	Yes
Q	No
R	Yes
S	Yes

Which material is Box Q most likely made of?

- (1) Steel
- (2) Glass
- (3) Copper
- (4) Titanium

16. Two similar jugs of ice water are placed on two different surfaces. They are then heated over fire. They are labeled as set-up A and set-up B, as shown in the diagram below.

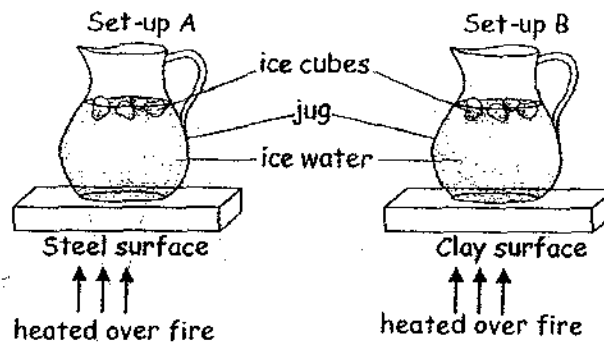

Which of the following situations are most likely to happen?

- A The ice water in both set-ups will lose heat.
- B The ice-water in both set-ups will gain heat.
- C The ice-cubes in B will melt faster than in A.
- D The ice-cubes in A will melt faster than in B.
- E Both surfaces will gain heat from the surroundings.

- (1) A and E only
- (2) A and B only
- (3) B and D only
- (4) C and D only

- 17 A ball was dropped from a height of 150cm above a cement floor. The graph below shows the height of the ball from the floor as it bounced.

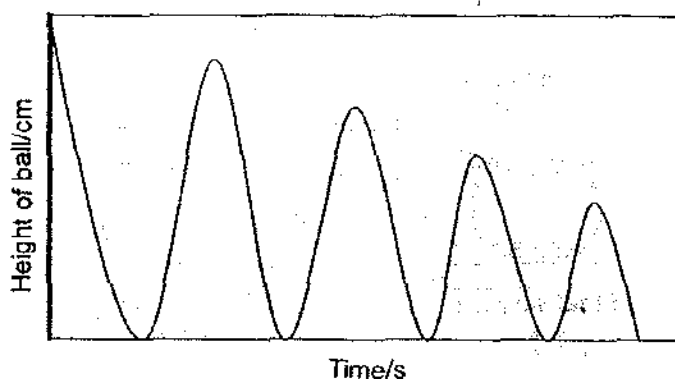

The graph indicates that each time the ball bounced, the height to which it bounced decreased. Which of the following explanations below is the reason for this?

- (1) The kinetic energy of the ball was greater than its potential energy.
 - (2) The potential energy of the ball was directly changed to heat and sound energy.
 - (3) The kinetic energy of the ball and the potential energy of the ball decreased over time
 - (4) Some energy of the ball was converted to sound and heat and used to overcome resistance.
- 18 The circuit diagram below shows 5 switches and 6 bulbs. In order for all the bulbs to light up, what is the minimum number of switches that need to be closed?

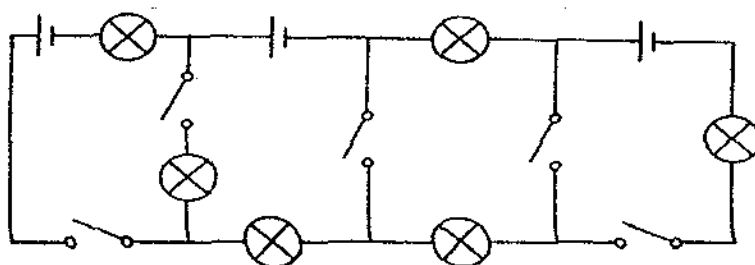

- (1) 2
- (2) 3
- (3) 4
- (4) 5

19 Junie saw a ball on the ground and kicked it. Junie had done work by _____

- A generating heat
- B overcoming friction
- C increasing the kinetic energy of the ball
- D increasing the potential energy of the ball

- (1) A and B only
- (2) B and C only
- (3) A, B and C only
- (4) A, B and D only

20 A ball was released from position X on an uneven track. The ball rolled down the slope and came to a stop. At which position is the ball likely to come to a final stop?

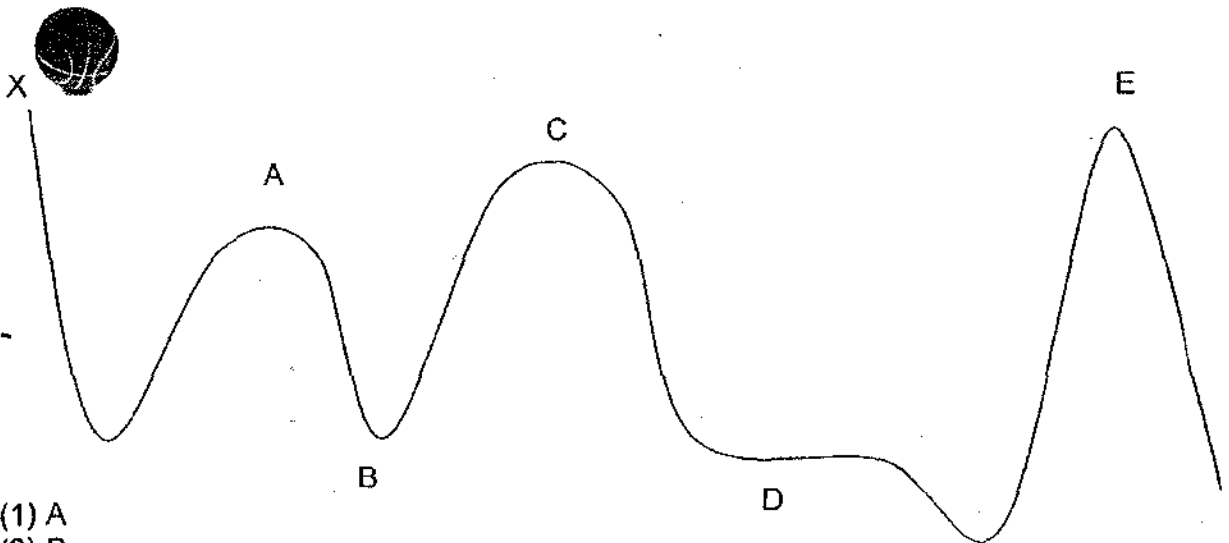

- (1) A
- (2) B
- (3) C
- (4) D

21 The circuit diagram below shows 5 bulbs lit up by 2 batteries.

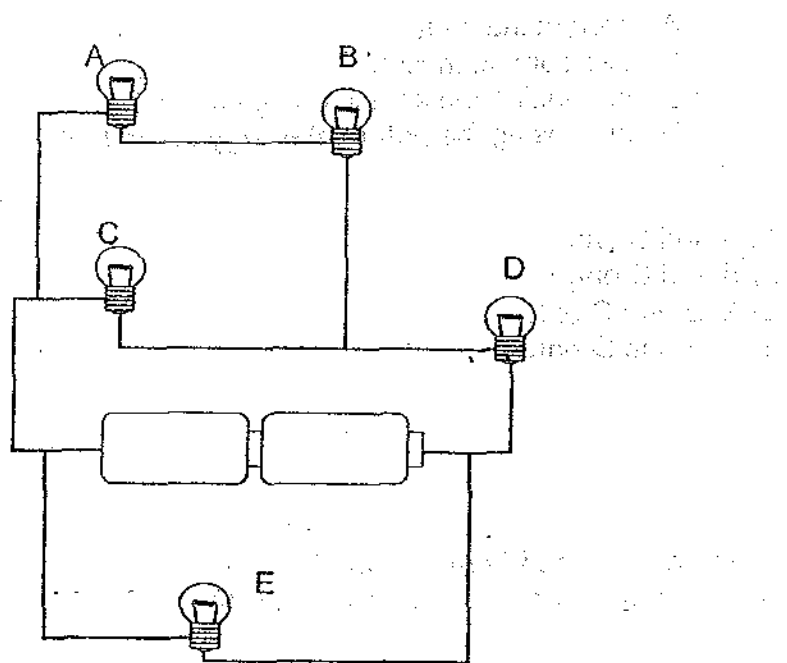

What will happen if bulb B is faulty?

- (1) No bulb will light up.
- (2) Only Bulbs C and D will light up.
- (3) All the other bulbs will still light up.
- (4) All the other bulbs except Bulb A will light up.

- 22 The graph below shows how the temperature inside an electrical flask changes over time. A thermostat is a special switch used to control its temperature.

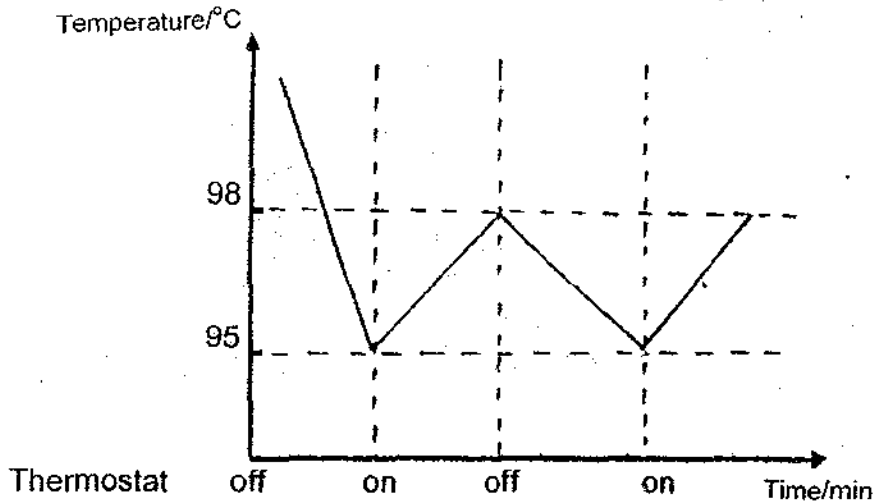

Which of the following observations of the thermostat are correct?
It switches _____

- A off when temperature reaches 95°C
 - B on when temperature reaches 95°C
 - C on when temperature reaches 98°C
 - D off when temperature reaches 98°C
- (1) A and B only
(2) A and C only
(3) B and C only
(4) B and D only

23 Tat Beng stood on a swing and moved to and fro through a height as shown in the diagram below.

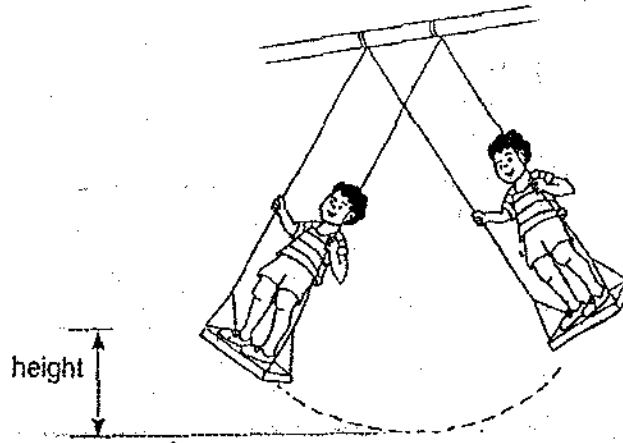

Which one of the following graphs correctly shows how the potential and kinetic energy of the swing change with the height?

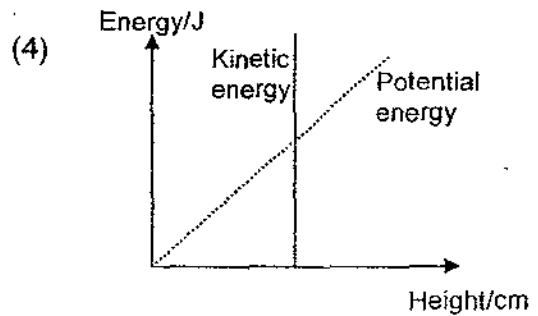
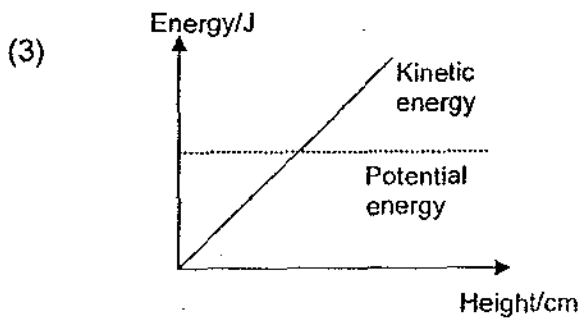
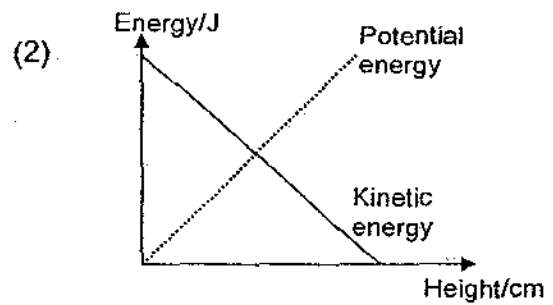
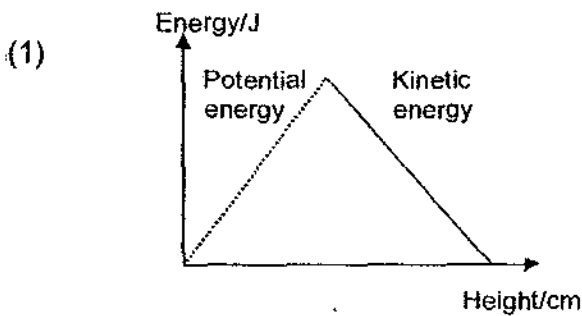

24 Mazri had a toy soldier as shown in the picture below.

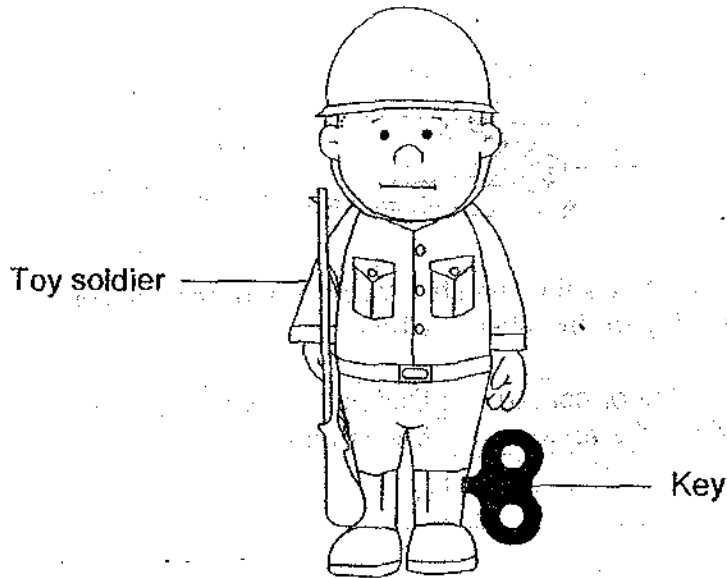

He carried out an experiment following the steps below:

- (i) He wound up the toy soldier a few times.
- (ii) He released the toy soldier on the ground.
- (iii) He measured the distance travelled by the toy soldier.
- (iv) He increased the number of turns of the key and repeat steps (ii) to (iv).

Possible aim(s) of his experiment could be to find out whether _____.

- A the number of turns of the key would affect the distance travelled
- B the amount of potential energy would affect the distance travelled
- C the distance travelled would affect the numbers of turns the key makes
- D the distance travelled would affect the amount of potential energy stored

- (1) A only
- (2) A and B only
- (3) B, C and D only
- (4) A, C and D only

- 25 Four similar tiled floors have been coated with different substances P, Q, R and S. A test is carried out to find out how far a car can move over these tiled floors.

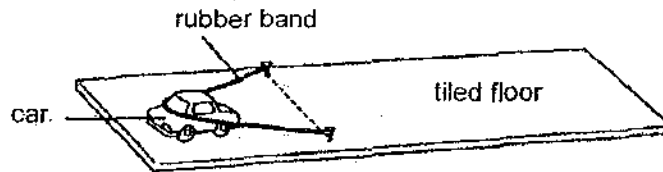

The table below shows the results. Which one of the following substances is the best choice for applying on the tiles in a bathroom?

	Tiled floor coated with substance	Distance moved by the toy car(cm)
(1)	P	25
(2)	Q	10
(3)	R	18
(4)	S	21

- 26 A tennis ball is thrown vertically upwards into the air and four children made the following statements of what they saw.

Jason The gravitational force increases as the ball moves upwards.
 Tina Gravity acts on the ball when all its upward force has been used up.
 Fiona The force of gravity acts on the ball throughout its journey up and down.
 Beverly There is no force acting on the ball when it stops momentarily at its highest point.

Who has/have made the correct inference?

- (1) Tina only
 (2) Fiona only
 (3) Beverly and Fiona only
 (4) Jason and Beverly only

27 A scale pan is attached to a spring as shown:

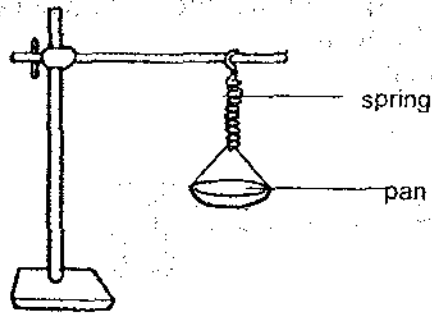

marks

Different numbers of pebbles are placed on the scale pan and the length of the spring is recorded. Which of the following graph correctly shows how the number of pebbles-marbles on the scale pan affects the length of the spring?

(1)

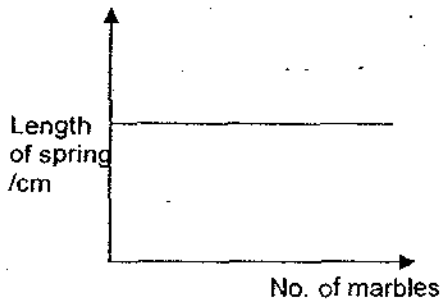

(2)

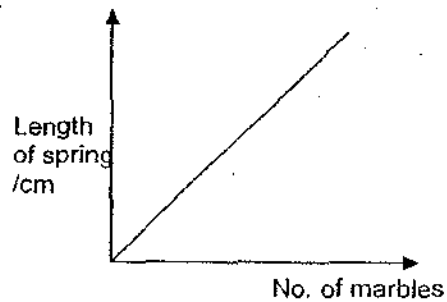

(3)

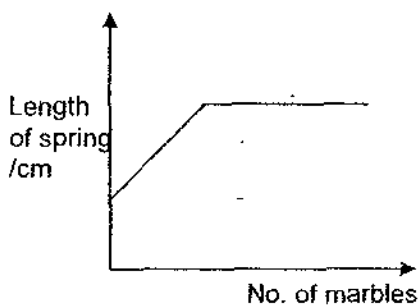

(4)

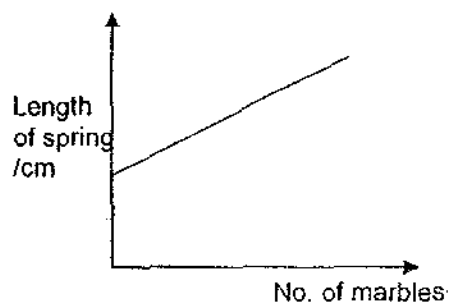

- 28 The diagrams below show a chest expander used by a body builder. When 2 springs are attached to the expander as shown in diagram A, a force of 12 kgf* is needed to extend the springs by 40cm.
(*kgf : kilogram force)

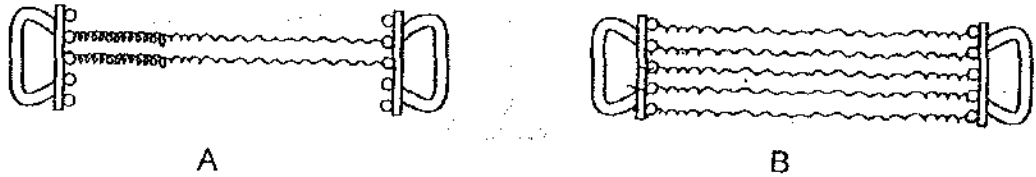

If 5 springs are attached, as shown in diagram B, how much force will the body builder need to extend the chest expander by 40cm?

- (1) 15kgf
- (2) 60kgf
- (3) 30kgf
- (4) 10kgf

- 29 The graph shows the change in kinetic energy of an athlete as he runs.

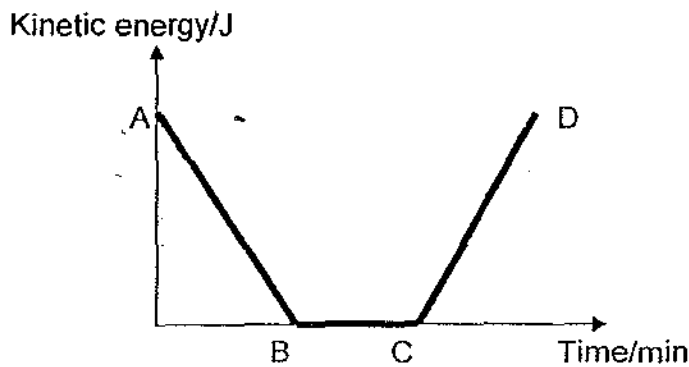

The part BC shows that the athlete is _____.

- (1) stationary
- (2) running up a slope
- (3) running down a slope
- (4) running at constant speed

30 The processes P, Q, R and S below involve different energy changes.

- P Burning some wood
- Q Releasing a wound-up toy
- R Rubbing a pebble on a rough floor
- S Using running water to move a turbine in a generator

Which of the following shows the energy changes correctly?

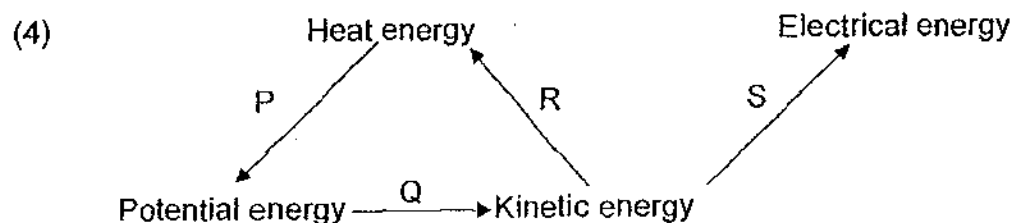
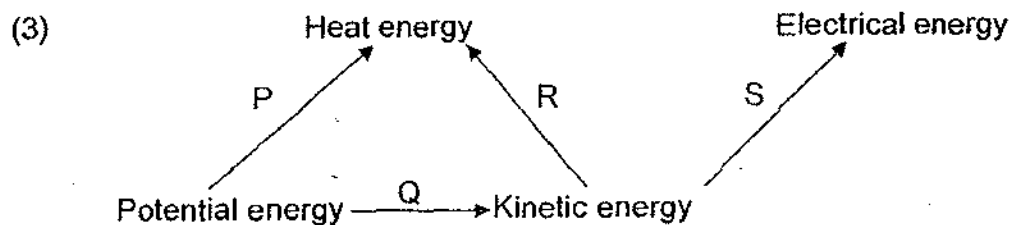
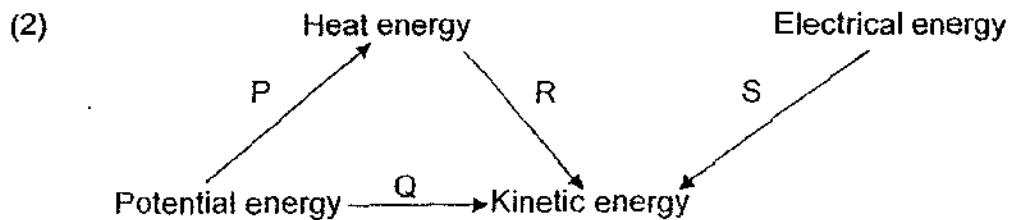
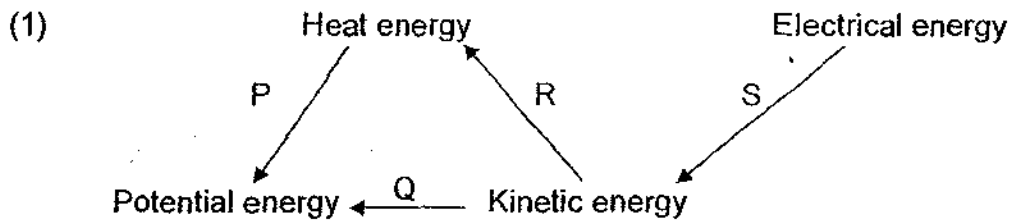

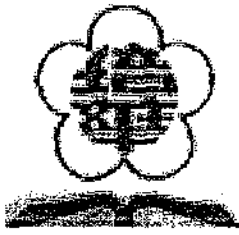

PEI HWA PRESBYTERIAN PRIMARY SCHOOL
FIRST CONTINUAL ASSESSMENT 2009
SCIENCE
PRIMARY 6

Name : _____ ()

Class : _____ (6)

Date : _____

BOOKLET B

Total time for Booklets A and B : 1 hour 45 minutes

Booklet	Type	Max. Marks	Marks Obtained
A	Multiple-Choice	60	
B	Structured Questions	40	10
Grand Total		100	

- Do not open this booklet until you are told to do so.
- Follow all instructions carefully.
- Answer all questions.
- Check your work carefully.

Section B : Structured Questions (40marks)

Answer the following questions in the spaces provided.

- 31 The chart below shows the characteristics of 5 different animals represented by the letters A, B, C, D, E. Study the diagram carefully and answer the following questions.

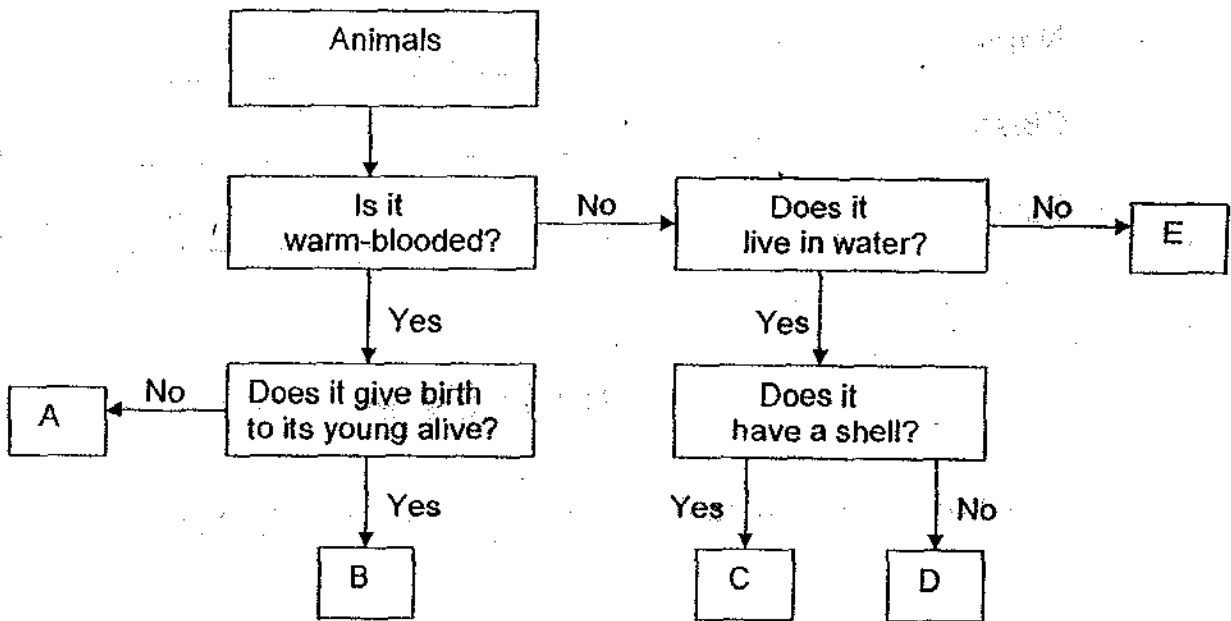

- (a) Name one common characteristic between animal C and E. [1]

- (b) Describe animal A. [1]

32 Amina wants to show that water is present in damp garden soil. She is only given the following materials :

- some garden soil
- 2 small flower pots
- 2 thick rubber bands
- 2 transparent plastic bags
- 2 beakers of sand

(a) Write down the steps that she should take to conduct a fair experiment. [2]

Step 1	Put some soil into one pot. Leave the other pot empty.
Step 2	Cover each pot with a transparent plastic bag.
Step 3	
Step 4	

(b) Assuming that there are no living organisms in the damp soil, what observations can Amina make to infer that water is present in the garden soil? [1]

- 33 Peter sets up an experiment next to the window in his classroom as shown below. He records the height of the water levels for the next 5 days.

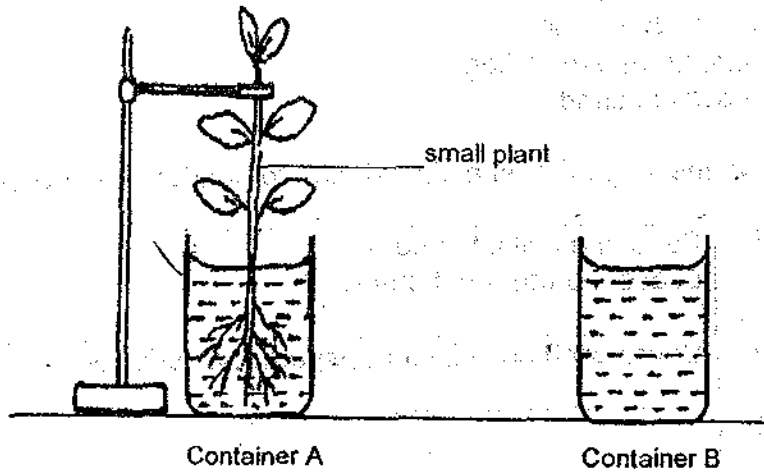

- (a) Make a clear comparison of the water level in both containers after 5 days. [1]

- (b) Give a reason for your answer in (a). [1]

- 34 Shu Hui wants to find out what happens to her pulse rate when she is exercising. She measures her pulse rate every minute for 10 minutes and plots the following graph.

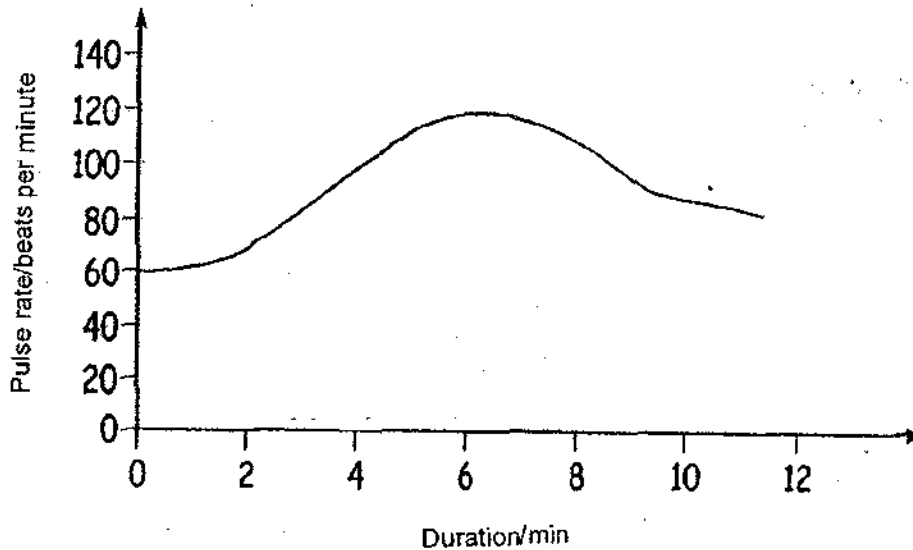

- (a) Explain why Shu Hui's pulse rate increases when she is exercising. [2]

- (b) What would her pulse rate be if she is at rest? [1]

35 The chart below shows the characteristics of 8 different objects. Refer to the chart and answer the questions that follow.

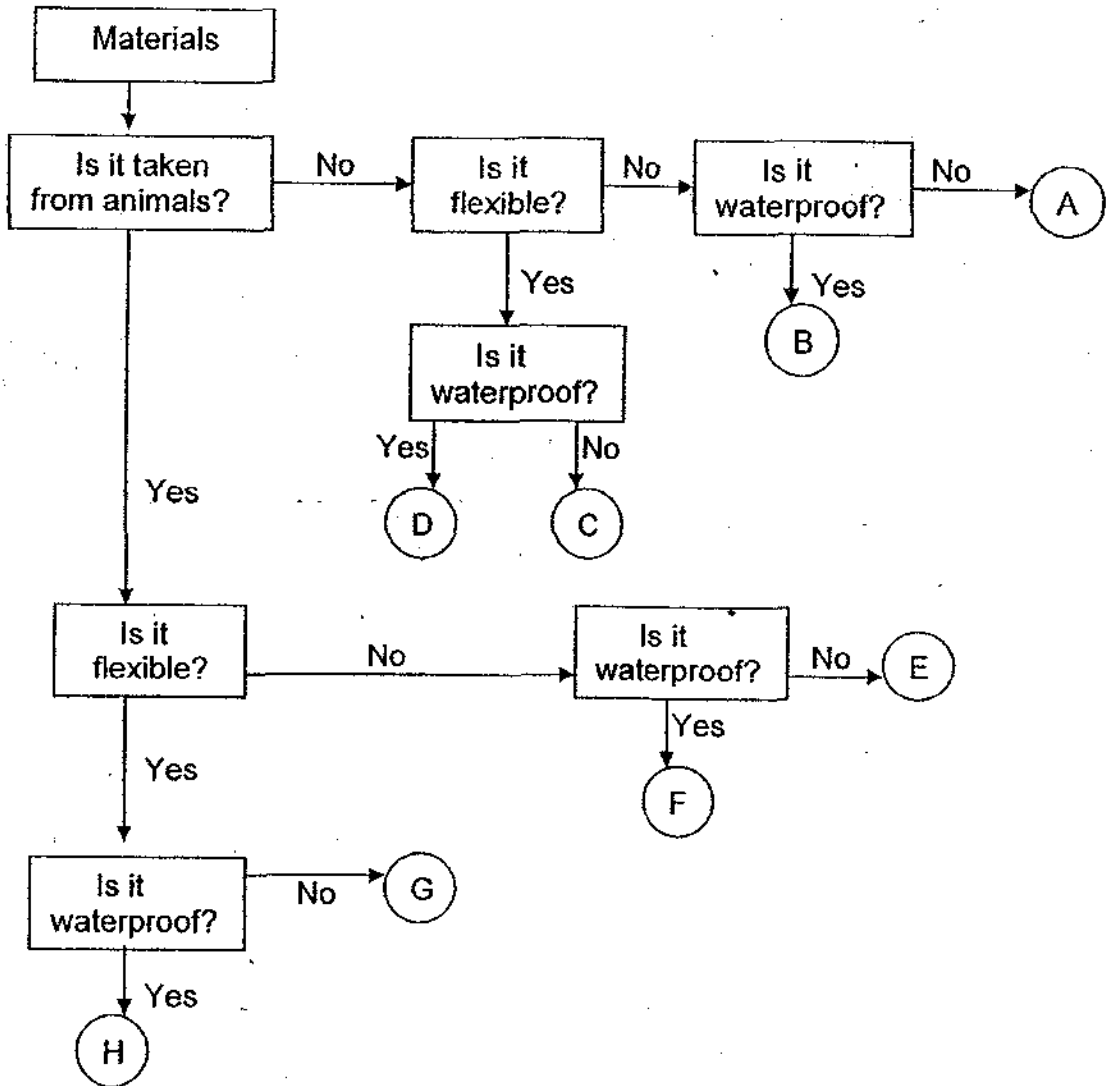

(a) Which object (A, B, C, D, E, F, G or H) best represents a piece of paper? [1]

(b) Suggest an object that could be represented by C. [1]

36 Jack constructed a circuit card with six points – A, B, C, D, E and F. The diagram below shows the circuit he constructed. Four of the points are connected by wires hidden behind the card.

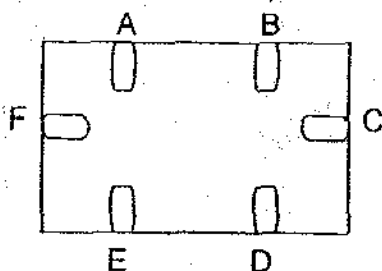

Circuit card (Front view)

The circuit card is tested with a circuit tester that is connected to two points at a time. The table below shows which 2 points, when connected, will light up the bulb.

Pairs of points connected	Did the bulb light up?
A and F	Yes
A and D	Yes
E and F	No
A and C	No
D and F	Yes
B and D	Yes

Draw only three lines (representing 3 wires) in the diagram below to match the results. [2]

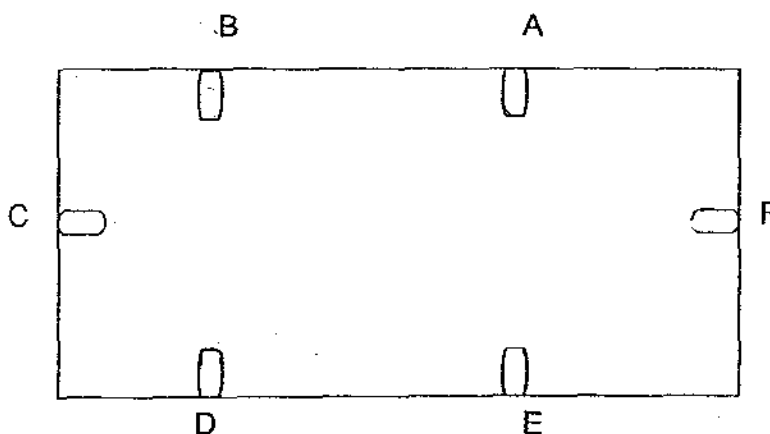

Circuit card (Back view)

37 The table below shows the properties of four materials.

Material	Conductor of Heat	Conductor of Electricity	Magnetic
S	Good	Yes	No
T	Good	No	Yes
W	Poor	No	No
V	Good	Yes	Yes

(a) Which material is steel? [1]

(b) Which material is silver? [1]

(c) Which material(s) listed above is/are most suitable for making the needle of a compass? Why? [1]

- 38 Jane fills 2 similar containers with hot water and places them on the table. She then covers one container with a lid and leaves the other uncovered. She then takes the temperature of water in the containers at intervals of 2 minutes. The results are recorded in the table below.

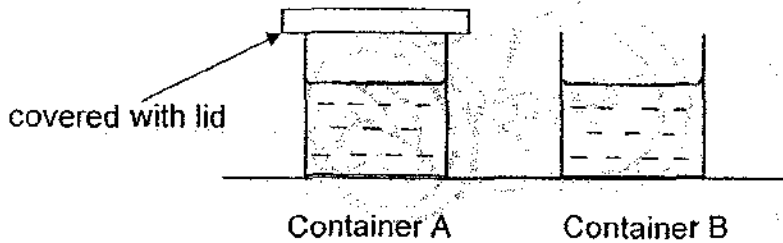

Time (min)	0	2	4	6	8	10
Temperature of water in A ($^{\circ}\text{C}$)	90	82	75	69	64	60
Temperature of water in B ($^{\circ}\text{C}$)	90	77	66	58	52	47

- (a) Based on the findings given, what can Jane conclude about the change in temperature of water in both containers? [1]

- (b) Jane allows the water in A and B to cool to room temperature. She then heats both containers again. She predicts that the temperature of water in A will increase faster than B.

Do you think Jane's prediction is correct? Give a reason for your answer. [2]

- 39 Julian makes a toy vehicle like the one shown below. The pencil is wound round and round so that it winds up the rubber band. A piece of candle wax next to the cotton reel lets the rubber band unwind slowly.

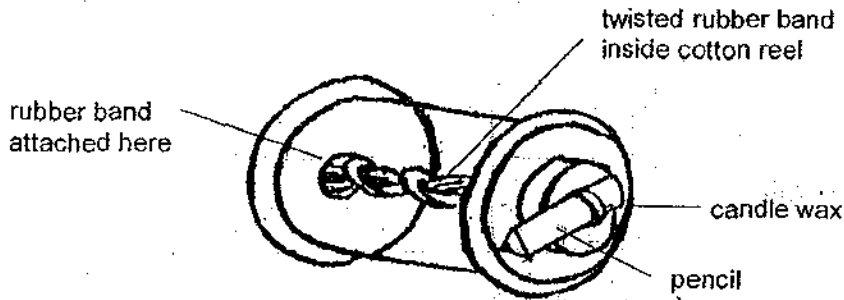

Julian tests the toy vehicle by letting it run along a horizontal table top.

- (a) What can he do to make the toy vehicle move faster? [1]

- (b) What is the relationship between the number of turns and the distance travelled by the toy vehicle? [1]

- (c) Tom wants to find out the distance travelled by the toy vehicle with 5 turns of the rubber band. He conducts the experiment twice and records the following reading.

	Distance travelled
1 st Try	18.5cm
2 nd Try	19.3cm

Tom notices that the readings differ. What can he do to improve the accuracy of the readings? [1]

40 Study the circuit diagram below.

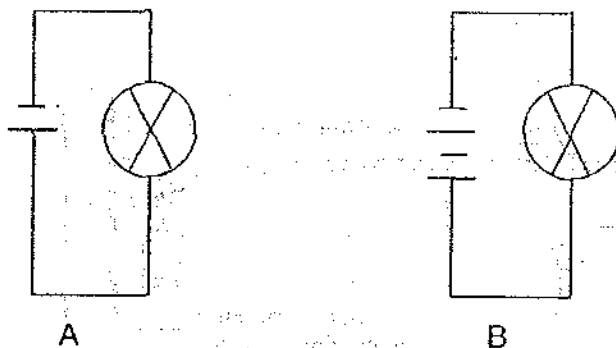

(a) In which set-up will the bulb light up brighter? [1]

(b) Using only the following items:
One bulb, three batteries, two switches and some wires, draw a circuit diagram such that there is a choice of 2 different degrees of brightness when the circuit is switched on. [2]

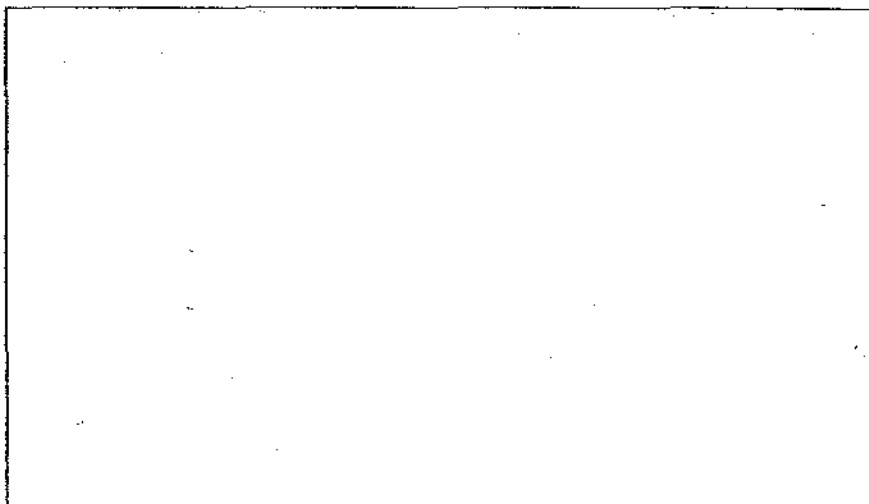

41 ^{Rayson} ~~Meng Wan~~ sets up the experiment as shown below.

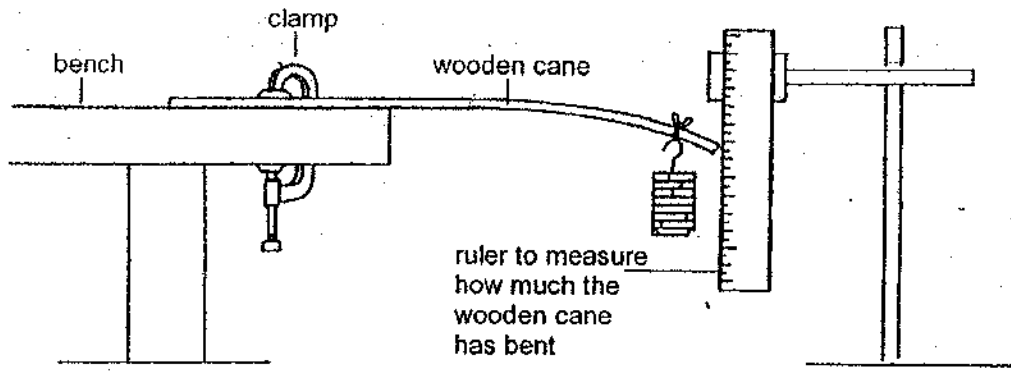

The graph below shows Rayson's results.

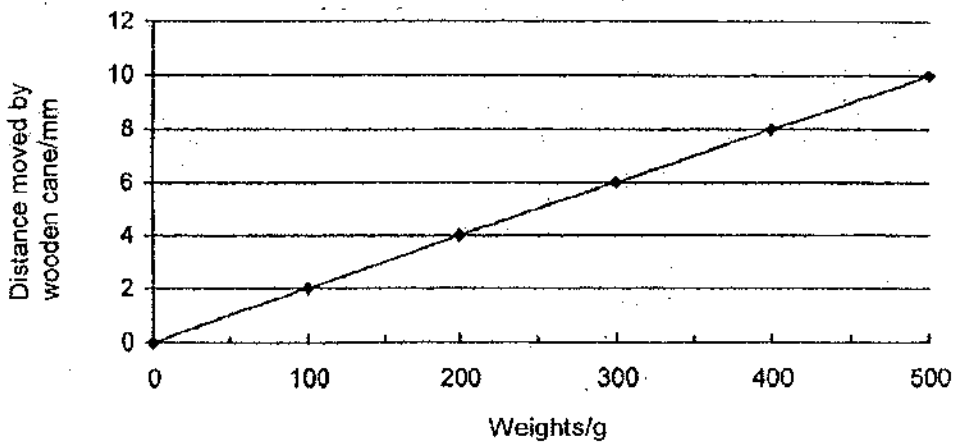

(a) What is the purpose of this experiment? [1]

(b) What conclusion can you draw from the experiment above? [1]

42 An alloy is a metal that is made when two different metals are melted under extreme heat and joined together. The graph below compares the strength and weight of four alloys, S, T, U and V. The strength of metal alloys is measured by the amount of force required to push them permanently out of shape.

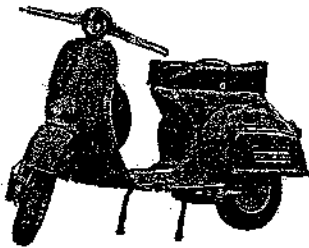
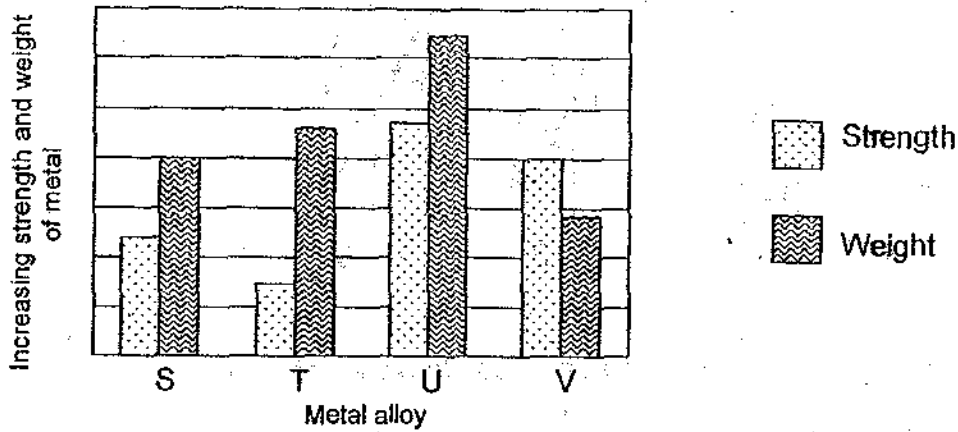

scooter



spectacles

(a) Which metal alloy (S, T, U or V) would be most suitable to make the frame of a pair of spectacles? Why? [1]

(b) Which metal alloy (S, T, U or V) would be most suitable to make the body of a scooter? Why? [1]

- 43 Annie used three sticks A, B and C to make catapults of different sizes. She used rubber bands of different lengths and thickness. She wanted to find out if the size of the stick would affect the average distance the pebble could travel.

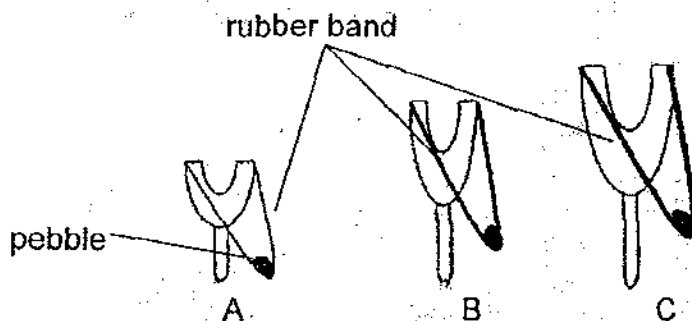

Annie's teacher then told her that her results were not reliable.

- (a) What should Annie do to improve the reliability of the experiment? [1]

- (b) State the energy conversion when the elastic part of the catapult was stretched till the pebble flew to hit an apple hanging on a tree. [1]

- 44 Sulimah hangs a magnet on a string as shown. When she places Object A near to one pole of the suspended magnet, that pole of the suspended magnet is attracted to Object A.

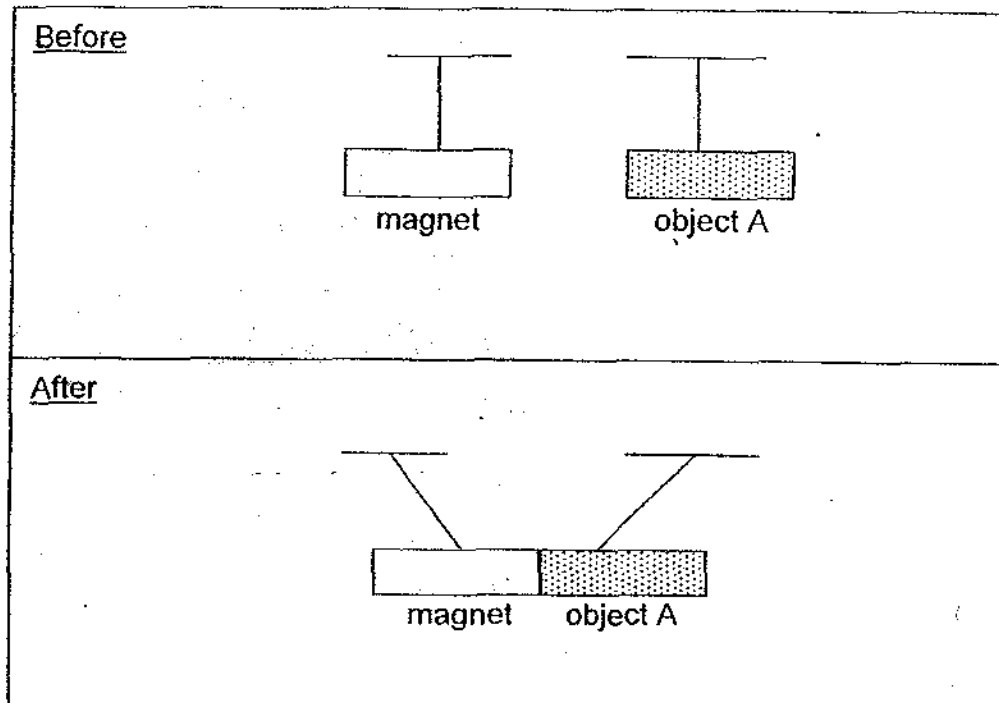

Sulimah concludes that Object A is a magnet.

Do you agree with Sulimah's conclusion? Explain your answer. [2]

- 45 A layer of mud was spread in a box as shown in the diagram below. Two identical marbles, A and B were held at a height of 10 and 15 cm respectively above the mud and released.

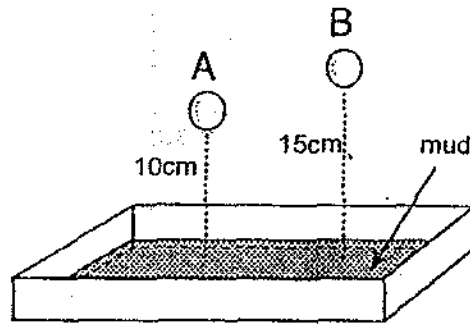

- (a) Which marble made a deeper hole? Why? [1]

- (b) What would you observe if two marbles, one heavier than the other, were to be dropped into the mud from the same height? [1]

- (c) What conclusion can you draw from (a) and (b)? [1]

46 You are given the following materials and two containers of water at different temperature.

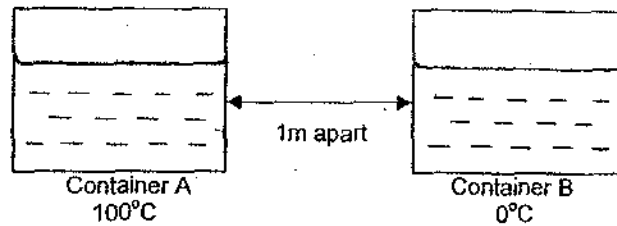
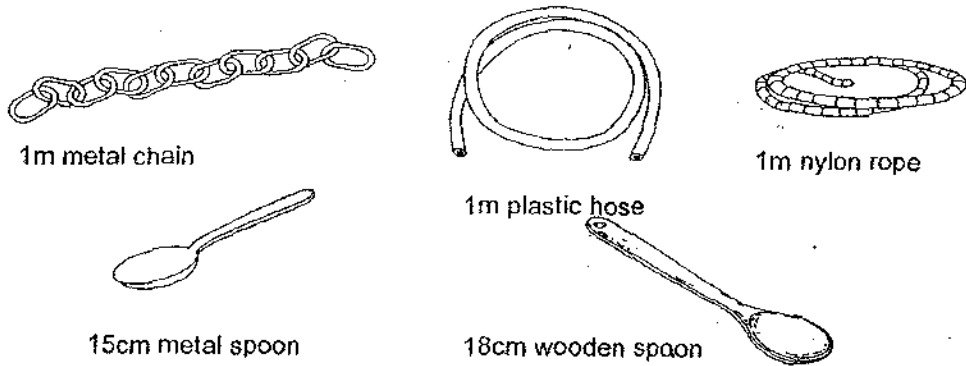

(a) In the box below, draw a diagram using the materials above to show how heat can be transferred from one container to another without pouring any water over. You need not use all the materials. [1]

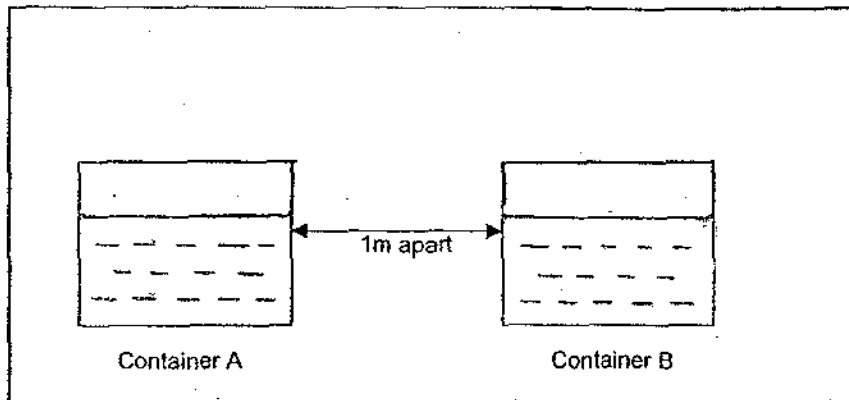

(b) Explain how heat is transferred between the containers in the method you have sketched above. [2]

End of Paper

ANSWER SHEET

EXAM PAPER 2009

**SCHOOL : PEI HWA PRIMARY
SUBJECT : PRIMARY 6 SCIENCE**

TERM : CA1

Q1	Q2	Q3	Q4	Q5	Q6	Q7	Q8	Q9	Q10	Q11	Q12	Q13	Q14	Q15	Q16	Q17
4	4	3	2	2	3	3	3	3	1	1	2	4	2	2	3	4

Q18	Q19	Q20	Q21	Q22	Q23	Q24	Q25	Q26	Q27	Q28	Q29	Q30
2	3	2	4	4	2	2	2	2	3	3	1	3

31)a)They are cold-blooded.

b)It is warm-blooded and it does not give birth to young alive.

32)a)3)Tie them up each with the thick rubber bands.

4)Observe the things inside the transparent plastic bag.

b)She would observe that water droplets are found in the plastic bag that are tied.

33)a)The water in container A contains lesser water than the water in container B.

b)The small plant in container A absorbs the water in container A and the water also evaporated due to sunlight.

34)a)Her heart must pump faster to increase the flow of carrying oxygen.

b)60 beats per minute.

35)a)Object C.

b)A cardboard.

36)

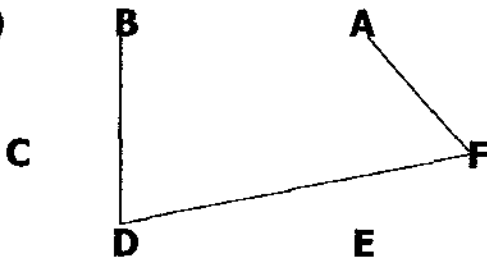

37)a)Material V. b)Material S.
c)Material V. It is a good conductor of heat, conductor of electricity and it is magnetic.

38)a)The temperature of B decreases faster than A.
b)Yes, She is right. Heat is trapped in A as it is covered. B is not covered so some heat will be lost to the surroundings.

39)a)He can turn the number of turns to wind the toy more.
b)The more the number of turns, the distance travelled by the toy vehicle increases.
c)He should repeat some more times to find the average.

40)a)Set-up B.

b)

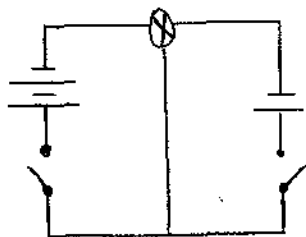

41)a)To find out if the different amount of weights affects the distance moved by the wooden cane.
b)The heavier the weight, the more the wooden cane bends.

42)a)Alloy V. The alloy used is strong and the lightest.
b)Alloy U. The alloy used is the strongest and heaviest.

43)a)She should use rubber bands of the same length and thickness and change only the size of the sticks.

b)Elastic potential energy→kinetic energy→gravitational potential energy→heat energy and sound energy.

44)No, object. A could be a magnetic material. If the other pole of object A and the magnet repel, then object A is a magnet.

45)a)B. It has more gravitational potential energy.

b)The heavier marble would make a deep per hole.

c)Height from the ground and weight both affect Gravitational Potential energy.

46)a)

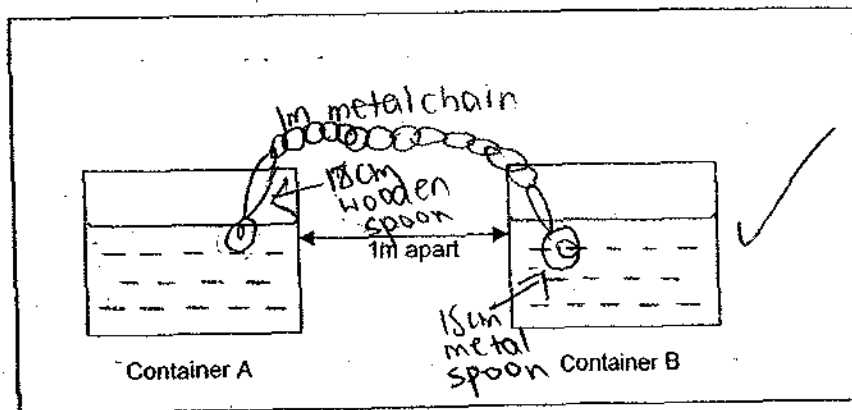

b)The heat from the hot water in container A travels through the 1m metal chain and 15cm metal spoon to the cold water in container B. Since metal is a good conductor of heat.