



Pei Hwa Presbyterian Primary School
First Semestral Assessment – 2009
Science
Primary 6
(Time: 1 hour 45 min)

Booklet A	/ 60
Booklet B	/ 40
Total	/ 100

Name : _____ ()

Class: _____ (6)

Date : _____

Parent's Signature: _____

Booklet A (60 marks)

For each question from 1 to 30, four options are given. One of them is the correct answer. Make your choice (1, 2, 3 or 4). Shade the correct oval (1, 2, 3 or 4) on the Optical Answer Sheet.

- 1 A cell went through cell division and produced two 'daughter cells'. How many cells would be produced from the single cell at the fourth generation?

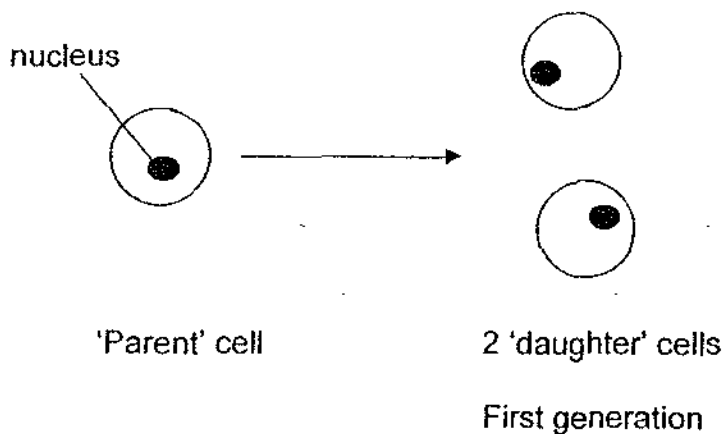

- (1) 6
- (2) 14
- (3) 16
- (4) 32

- 2 The diagram below shows cross-sections of two types of human blood vessel, Q and R.

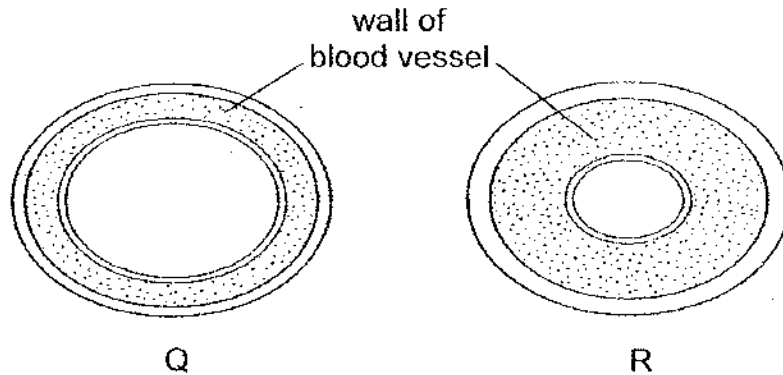

Which of the following statements are true about the blood vessels?

- A The walls of blood vessel R are thin.
- B The walls of blood vessel Q are thick.
- C Blood vessel Q carry blood back to the heart from other parts of the body.
- D Blood vessel R carry blood away from the heart to other parts of the body.

- (1) A only
- (2) B and C only
- (3) C and D only
- (4) A, B and D only

- 3 The diagram below shows an investigation carried out by a pupil. The plant had leaves that were green in the middle and white around the edges. The plant was left in the open. Which two leaf areas lack only one factor needed for photosynthesis?

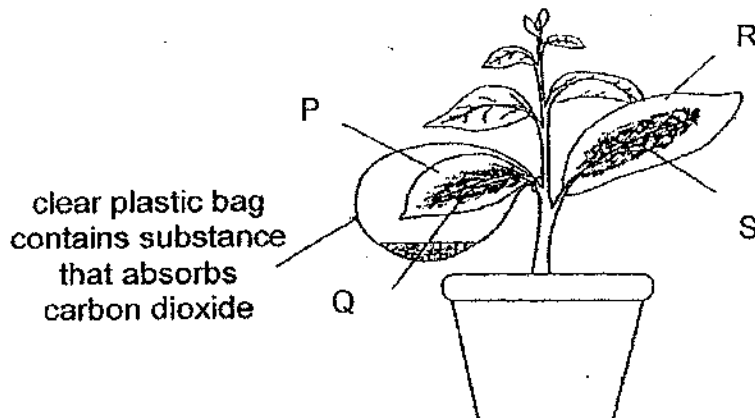

- (1) P and Q
- (2) R and S
- (3) P and S
- (4) Q and R

- 4 An experiment as shown below was set up to investigate the living conditions of woodlice. The box contains soil which is divided into four sections, W, X, Y and Z. Some woodlice were released into the centre of the box.

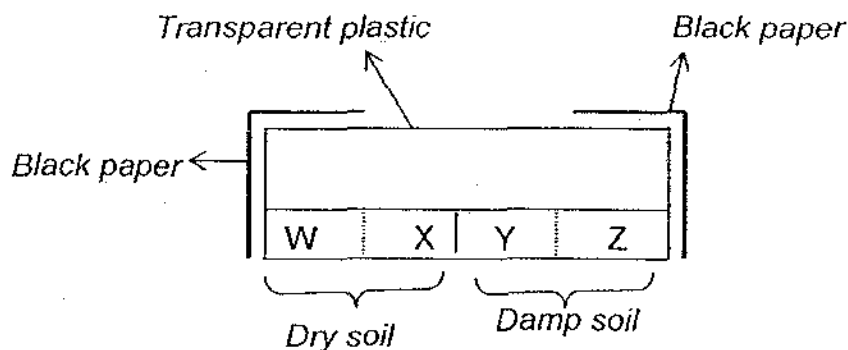

Side view of set-up

After some time, where would the woodlice most likely be found?

- (1) Z only
 - (2) W only
 - (3) X and Y only
 - (4) W, Y and Z only
- 5 The cockroach's life cycle shown below is wrongly drawn. Which are the incorrect stage/stages?

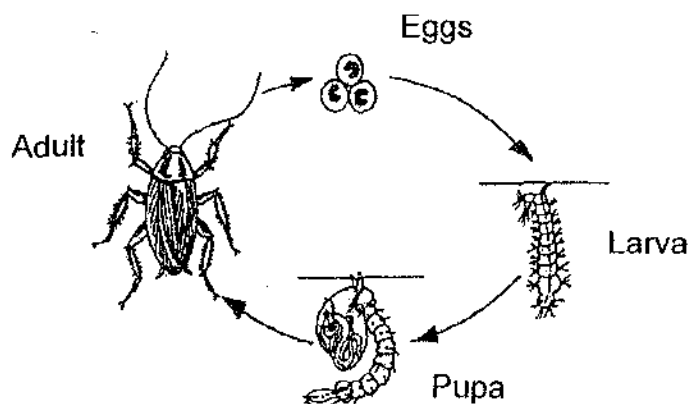

- (1) egg stage only
- (2) larval stage only
- (3) egg and adult stages only
- (4) larval and pupal stages only

- 6 The diagram below shows part of the human digestive system. In which part W, X, Y or Z is water absorbed from the undigested food?

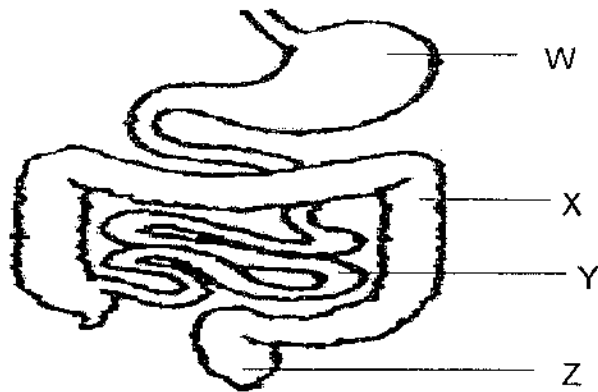

- (1) W
- (2) X
- (3) Y
- (4) Z

- 7 In the experiment below, each test-tube contains some seeds on cotton wool.

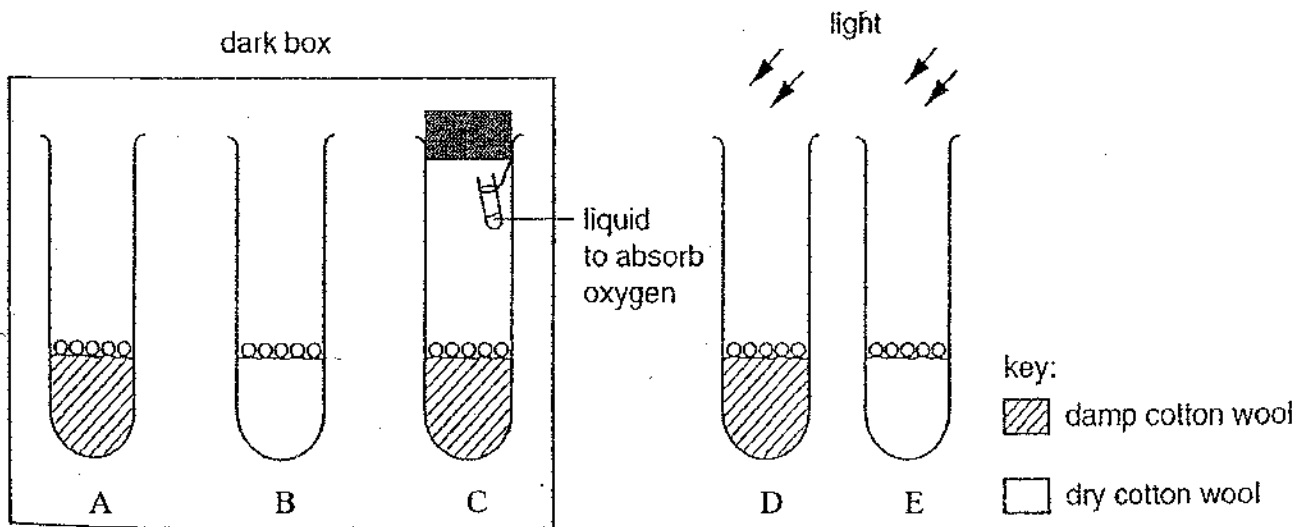

Which two test-tubes should be compared to investigate whether light is needed for germination of these seeds?

- (1) A and D
- (2) B and E
- (3) C and D
- (4) A and E

- 8 The classification chart below shows how plants are useful to man. Which of the following groups of plants are useful in all three ways stated in the chart?

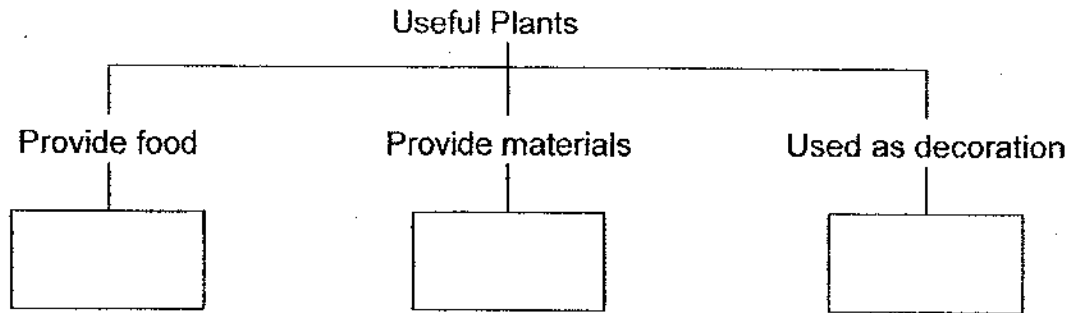

- (1) rubber tree and rose plant
- (2) rain tree and rambutan tree
- (3) coconut tree and bamboo plant
- (4) string bean plant and cotton plant

- 9 The diagram below shows a joint of the human arm.

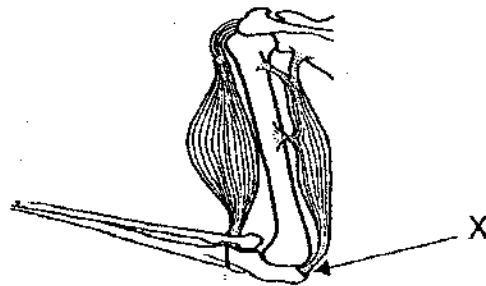

Which of the following joints of the human skeletal system move the same way as the part marked 'X'?

- | | |
|---|--------|
| A | hip |
| B | knee |
| C | wrist |
| D | finger |

- (1) A and C only
- (2) B and D only
- (3) A and D only
- (4) B and C only

10 Study the food web shown below.

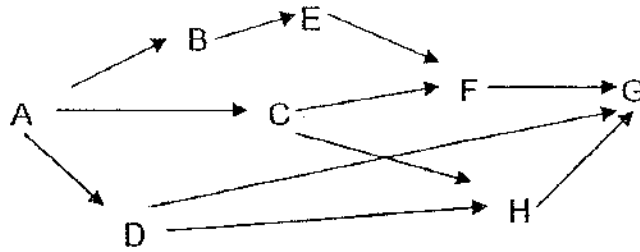

Which of the following statements is true?

- (1) Without C and E, H will die.
- (2) A, B and D are food producers.
- (3) H is both a prey and a predator.
- (4) F is a prey of E but a predator of G.

11 Study the following flow-chart carefully.

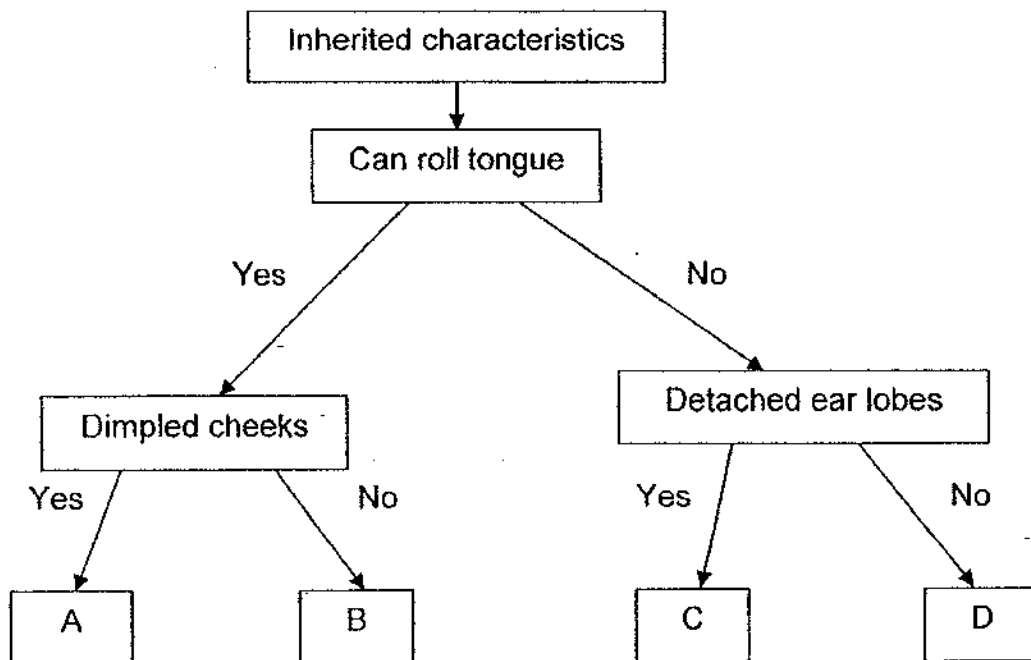

Rajah cannot roll his tongue and has detached ear lobes. Where would you put him in the above chart?

- (1) A
- (2) B
- (3) C
- (4) D

12 The diagram below shows nine organisms in a food web. Which of the organisms is a food producer and which is a carnivore (meat-eater)?

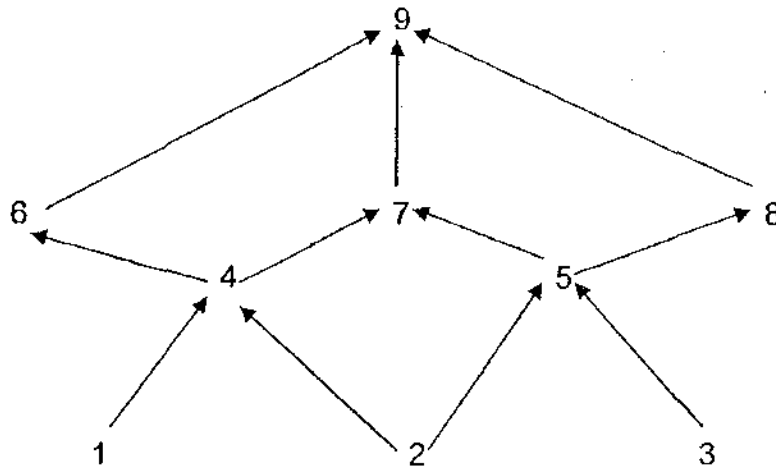

	food producer	carnivore
(1)	2	6
(2)	7	8
(3)	4	3
(4)	5	8

13 Study the following classification of leaves carefully.

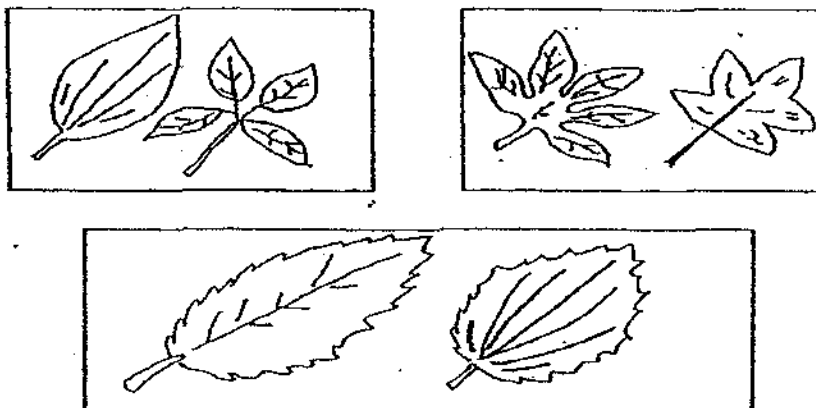

The leaves above are grouped according to their _____.

- (1) edges
- (2) shapes
- (3) patterns
- (4) surfaces

14 Which of these comparisons between a spider and bee is correct?

	spider	bee
(1)	wings present	no wings
(2)	feelers present	no feelers
(3)	three pairs of legs	four pairs of legs
(4)	body divided into two parts	body divided into three parts

15 Three jars were set up as shown.

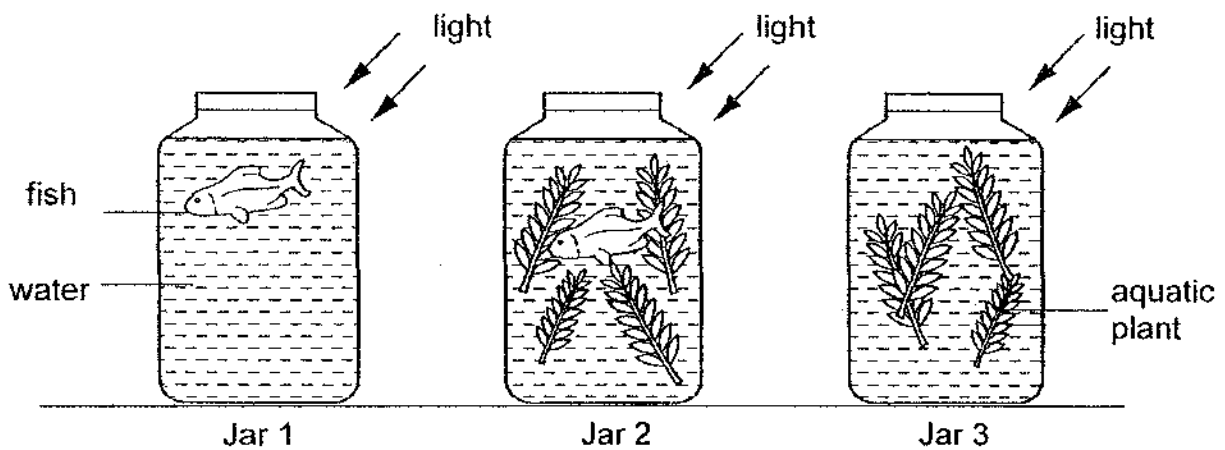

How will the amount of dissolved carbon dioxide in the water of each jar change?

	Jar 1	Jar 2	Jar 3
(1)	increases	decreases	increases
(2)	decreases	increases	decreases
(3)	decreases	decreases	no change
(4)	increases	no change	decreases

16 A pupil was trying to find the volume of a stone, but he mixed up the instruction cards.

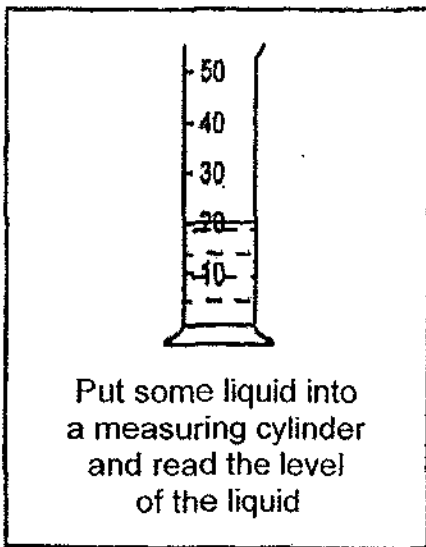

Card 1

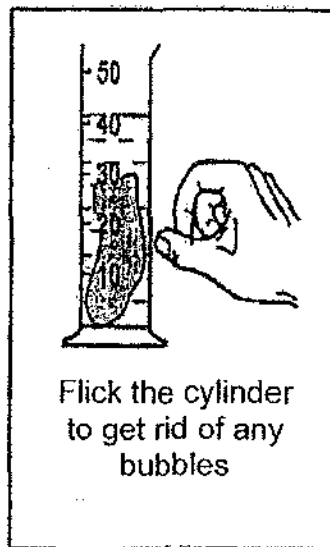

Card 2

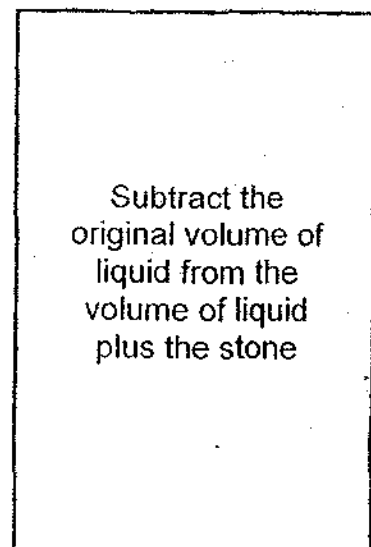

Card 3

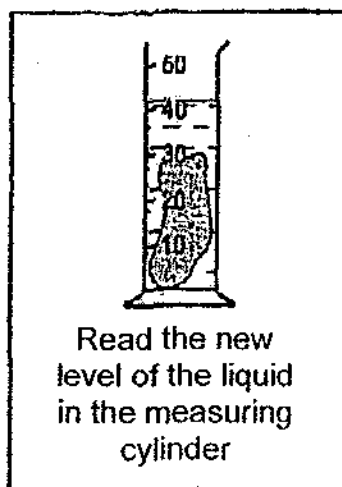

Card 4

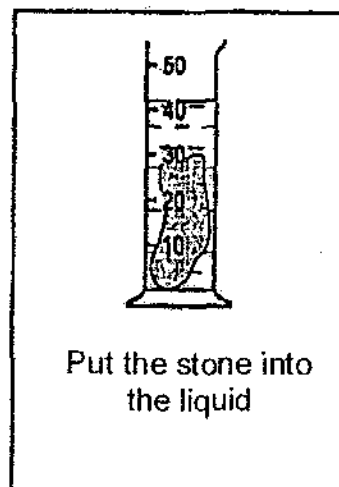

Card 5

What order should the cards be in?

- (1) 5 → 2 → ~~3~~¹ → 4 → ~~1~~³
- (2) 1 → 5 → 4 → 2 → 3
- (3) 5 → 2 → 3 → 4 → 1
- (4) 1 → 5 → 2 → 4 → 3

17 Four aquariums were set up containing different organisms and having different conditions. In which aquariums will all the organisms survive the longest time?

	Organisms in the aquarium	Condition
(1)	snails and algae	no light
(2)	angelfish and guppies	light
(3)	hydrilla and swordtails	light
(4)	duckweeds and goldfish	no light

18 The table below gives some properties of four substances A, B, C and D.

Substance	Colour	Can it dissolve in water?	Is it a magnetic material?
A	Black	No	Yes
B	White	Yes	No
C	White	No	No
D	Blue	Yes	No

A Science teacher mixes some fine grains of the four substances together. He asks his pupils to carry out an experiment to separate them. Which two substances would be most difficult for his pupils to separate?

- (1) A and B
- (2) C and D
- (3) A and C
- (4) B and D

19 Study the following electric circuit carefully.

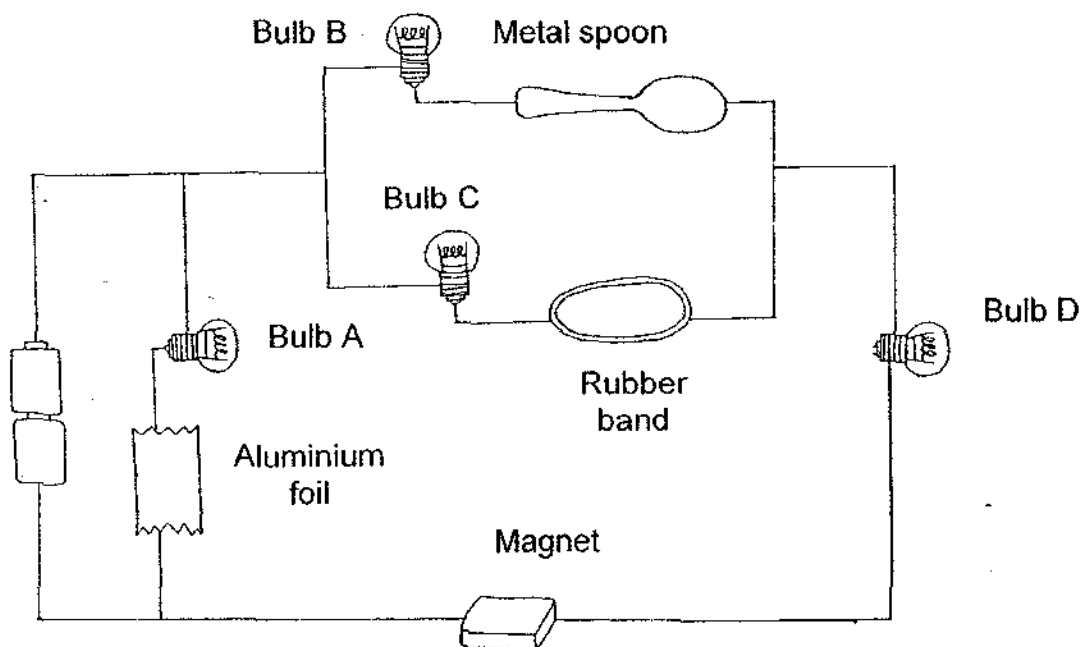

Which of the bulb/s in the electric circuit will light up?

- (1) A and B only
- (2) C and D only
- (3) A and D only
- (4) A, B and D only

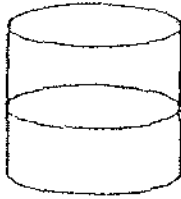

Container A – bin



Container B – plate

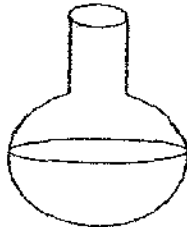

Container C – bottle

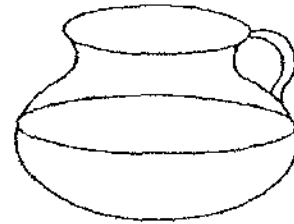

Container D – jug

The diagram above shows four plastic containers A, B, C and D. They are of different sizes and shapes. Peng Peng poured water into each container until it was half-filled. The containers were left in the open.

Which of the containers would have the least amount of water left after a few hours?

- (1) A
- (2) B
- (3) C
- (4) D

21 Study the table below carefully.

Property \ Object	X	Y	Z
Waterproof	Yes	Yes	No
Elastic	No	No	No
Allows some light to pass through	No	Yes	No
Breaks easily when dropped	No	Yes	No

Which one of the following correctly identifies X, Y and Z?

	X	Y	Z
(1)	Metal can	Wine glass	Book
(2)	Ceramic cup	Rubber band	Pebble
(3)	Plastic cup	Bicycle tyre	Thread
(4)	Copper coin	Wooden table	Sponge

22 The pictures below show three different ways of carrying a load by two workers (Y and Z) using a stiff pole. In Picture 1 and Picture 2, the load is at the equal distance from Y and Z. In Picture 3, the load is closer to Y.

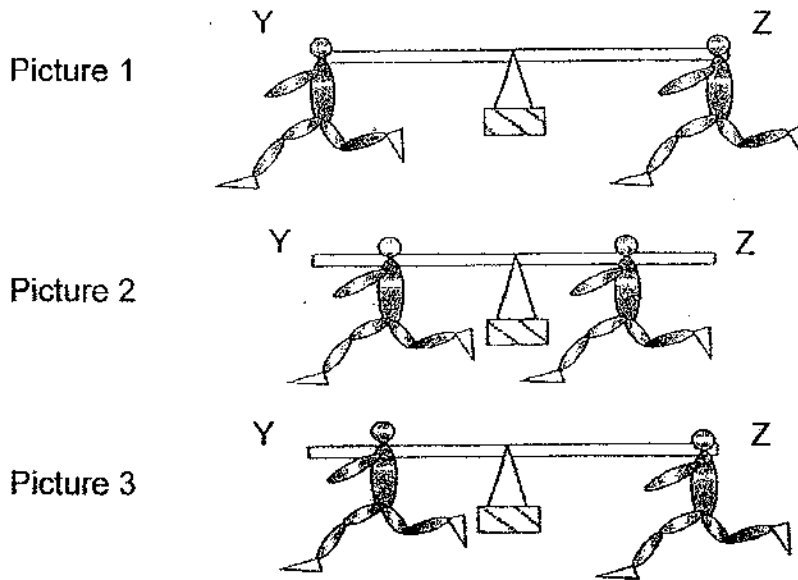

Which of the following statements about the three pictures are true?

- A In Picture 3, the effort from Y is less than the effort from Z.
- B In Picture 3, the effort from Y is greater than the effort from Z.
- C In Pictures 1 and 2, the effort from Y is equal to the effort from Z.

- (1) A only
- (2) C only
- (3) A and B only
- (4) B and C only

23 Study the classification diagram below.

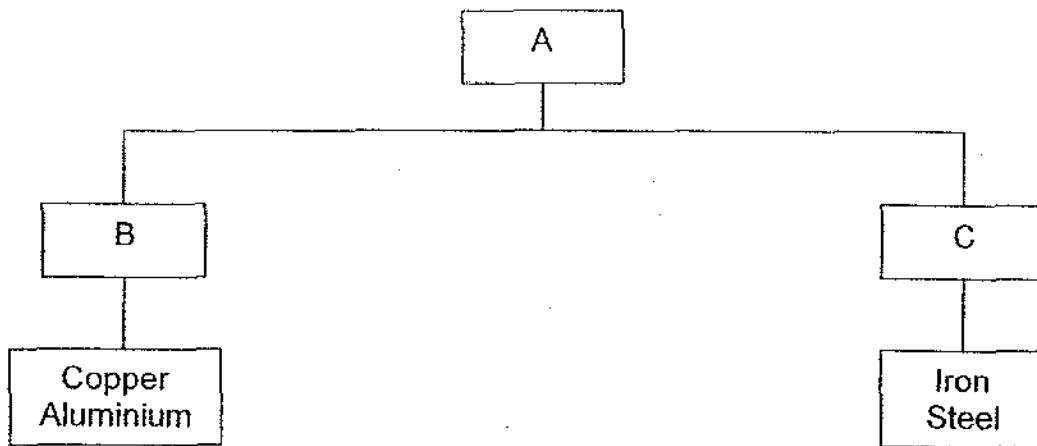

Which of the following descriptions about A, B and C are correct?

	A	B	C
(1)	Metals	Cannot conduct heat	Can conduct heat
(2)	Materials	Cannot conduct electricity	Can conduct electricity
(3)	Magnets	Cannot be pulled by a magnet	Can be pulled by a magnet
(4)	Metals	Cannot be made into magnets	Can be made into magnets

24 The diagram below shows the apparatus set-up to investigate the absorption of heat.

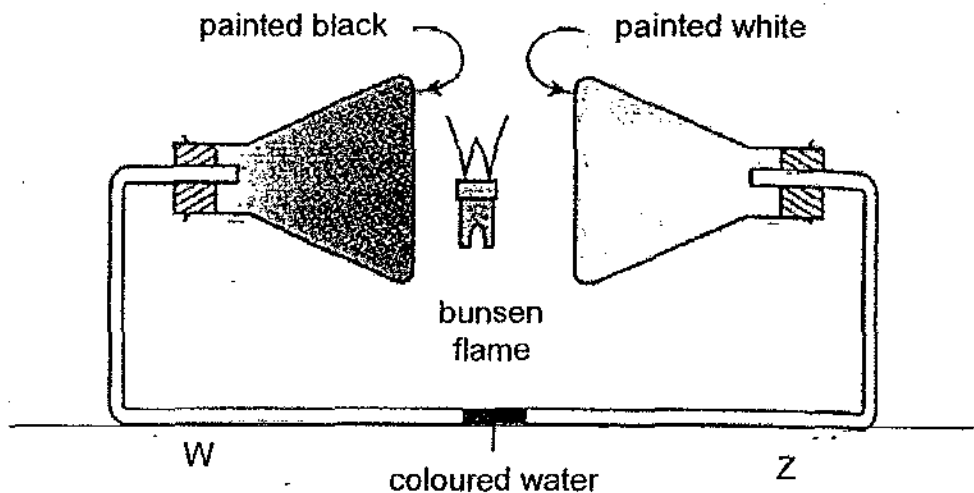

Which of the following observation is true?

- (1) The coloured water moves towards Z.
- (2) The coloured water moves towards W.
- (3) The coloured water remains stationary.
- (4) The coloured water expands and contracts.

25 The diagram below shows an experiment to investigate the effect of gravity on a spring.

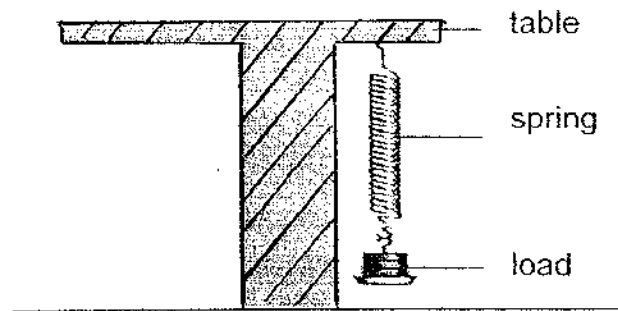

What inferences are true about the experiment?

- A The spring experiences a pulling force caused by the table.
- B The extension of the spring depends on the weight of the load.
- C The weight of the load is the Earth's gravity acting on the load.

- (1) A and B only
- (2) B and C only
- (3) A and C only
- (4) A, B and C

26 Three electromagnets X, Y and Z were made using the same length of wire and identical iron cores. X had six turns and connected to two batteries. Y had six turns and connected to one battery. Z had eight turns and connected to two batteries.

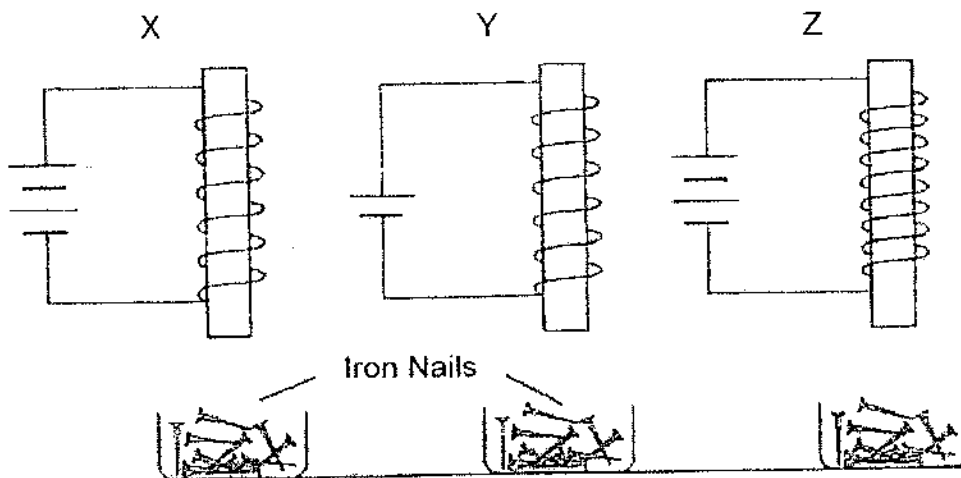

The electromagnets were brought near some iron nails. Four nails were attracted to X. What would be the possible number of iron nails attracted to Y and Z?

	Y	Z
(1)	2	4
(2)	2	6
(3)	4	4
(4)	4	6

27 Dave set up an experiment as shown below to form a shadow on the screen.

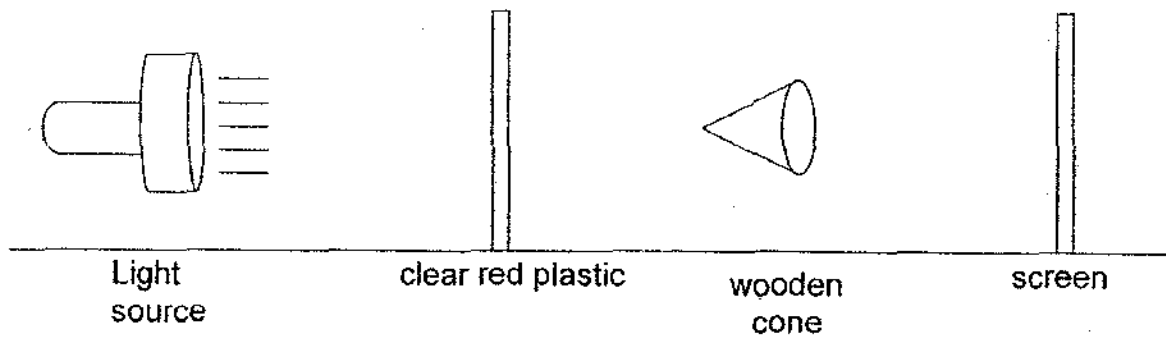

Which one of the following shows the shadow formed on the screen?

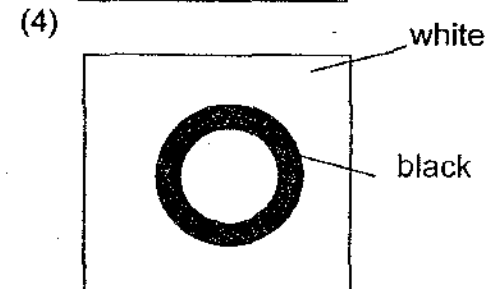
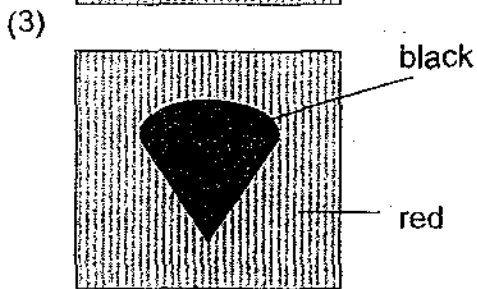
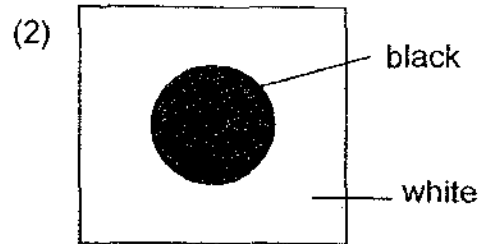
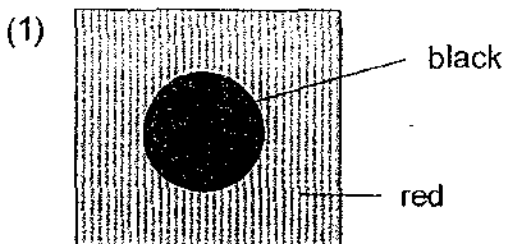

28 Study the diagram below carefully, which of the switches need to be closed so that the bell will work? ^{only}

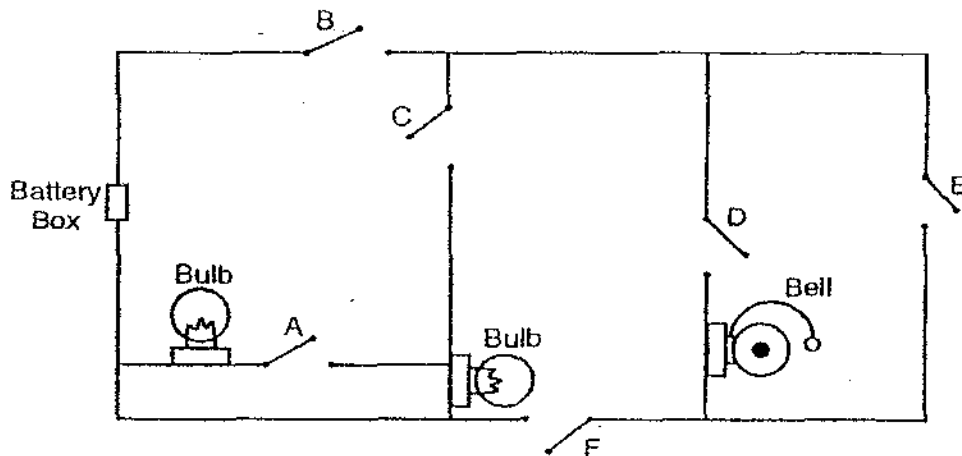

- (1) A, B and C only
- (2) B, D and F only
- (3) D, E and F only
- (4) B, C, D and F only

29 The graph below shows the relationship between the force applied and the corresponding extensions of spring S, spring T and spring U.

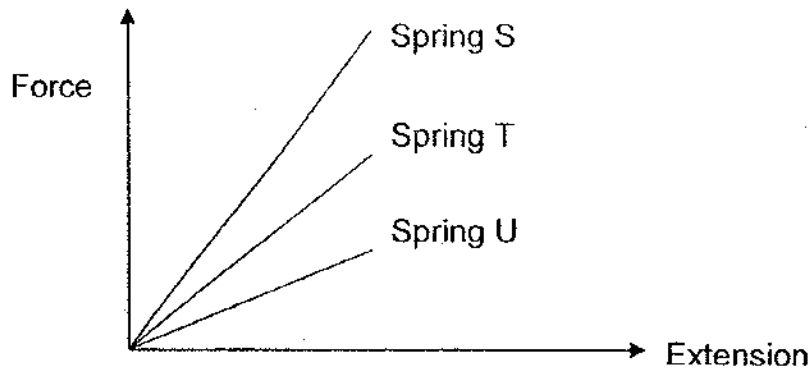

It can be concluded from the graph that spring _____.

- (1) S is as stiff as spring T
- (2) T is stiffer than spring S
- (3) U is less stiff than spring T
- (4) S is less stiff than spring U

30 Which of the following machines use less effort to overcome a larger load?

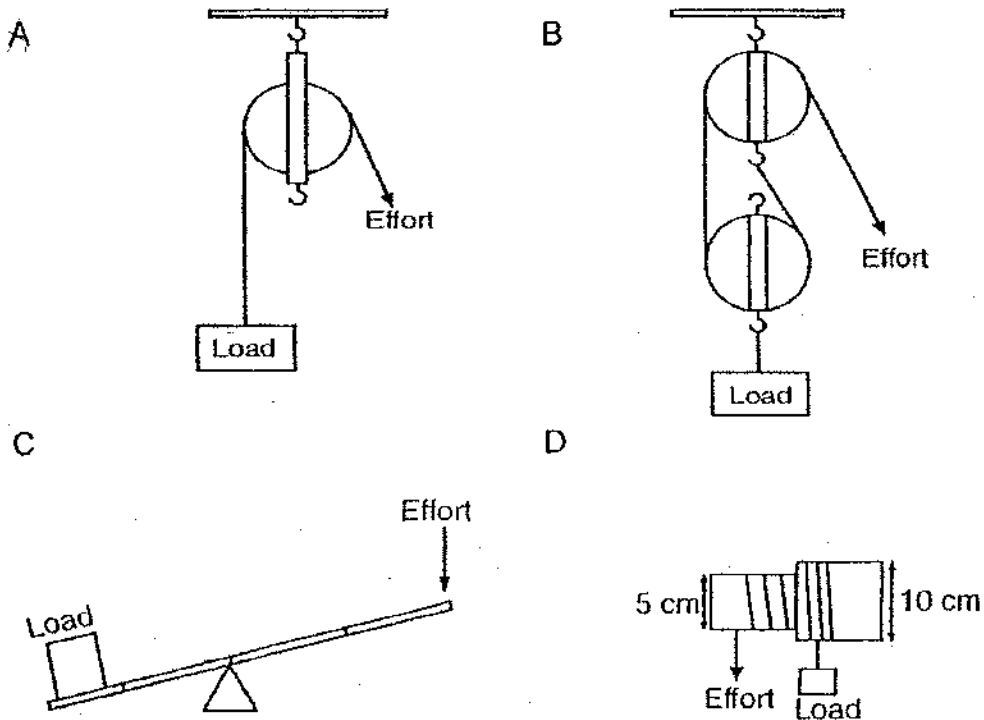

- (1) A and B only
- (2) B and C only
- (3) A, C and D only
- (4) B, C and D only



Pei Hwa Presbyterian Primary School
First Semestral Assessment – 2009

Science
Primary 6
(Time: 1 hour 45 min)

Booklet A	/ 60
Booklet B	/ 40
Total	/ 100

Name : _____ ()

Class: _____ (6)

Date : _____

Parent's Signature: _____

Booklet B (40 marks)

For questions 31 to 46, write your answers in this booklet.

The number of marks available is shown in brackets [] at the end of each question or part question.

31 The diagram below shows a food web in an area of forest.

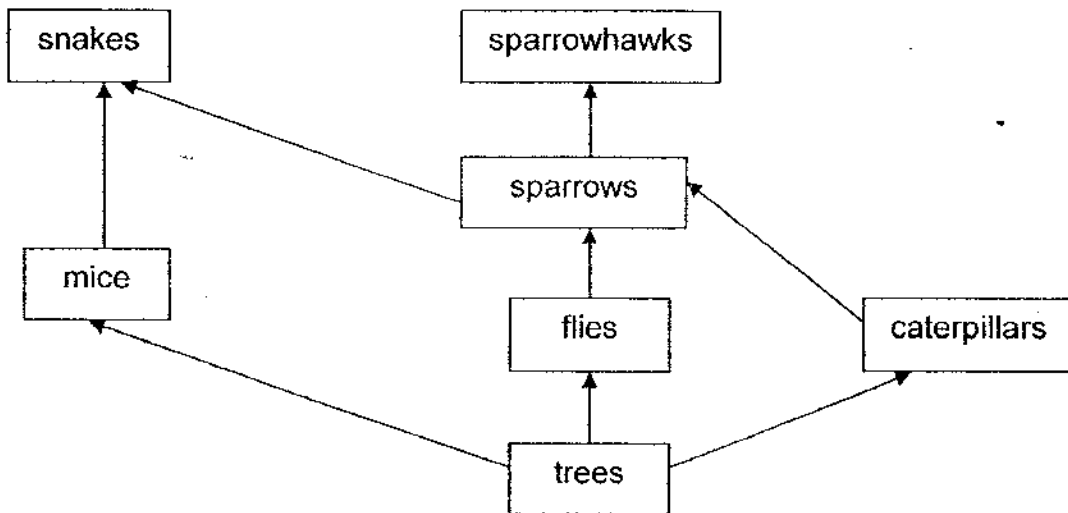

Wind blows insecticide from a neighbouring field into the forest.

(a) Explain why the number of mice does not change.

[1]

(b) Explain why there is a larger decrease in the number of sparrowhawks than the decrease in the number of snakes.

[2]

32 The diagrams below show a type of 'ant plant' and one of its modified, hollow leaves cut to show the activities taking place inside it.

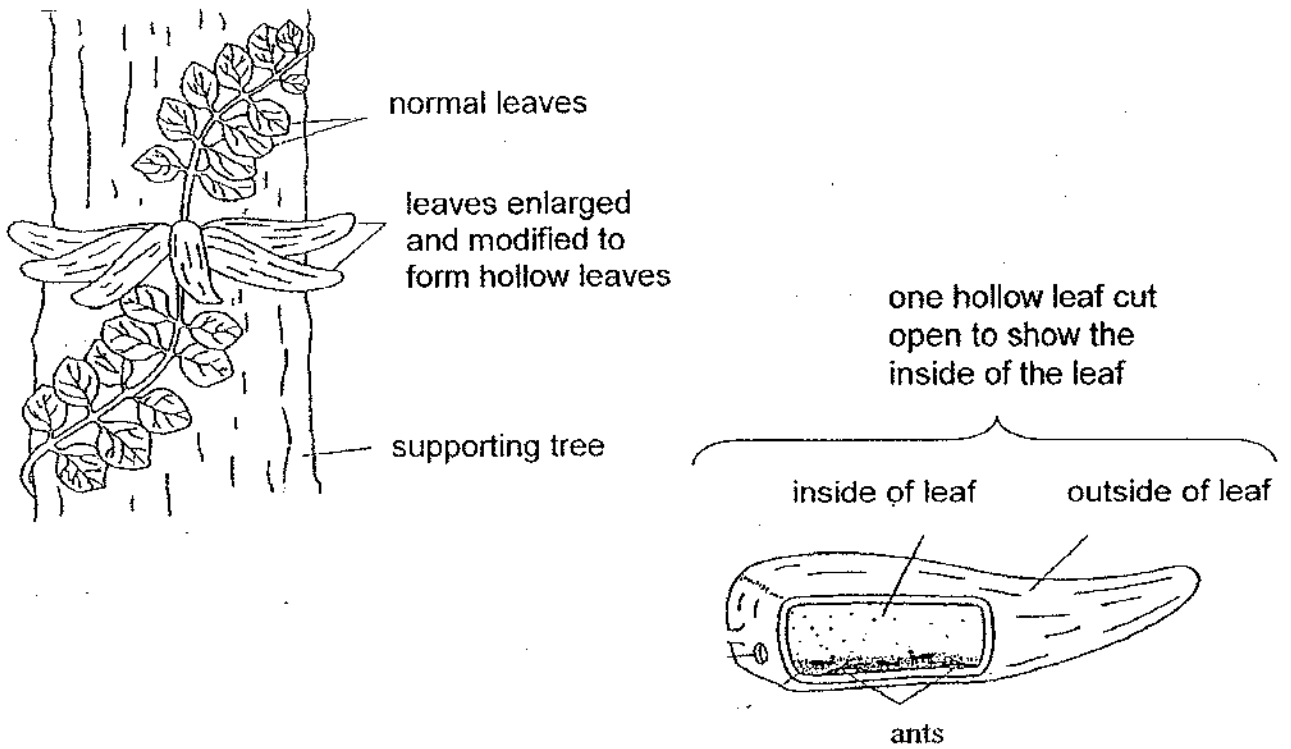

(a) Name the process used by the plant to make food. [1]

(b) Explain how this process is important to the ants living in the modified leaves? [2]

33 In the diagram below, Harry has classified eight animals according to their characteristics.

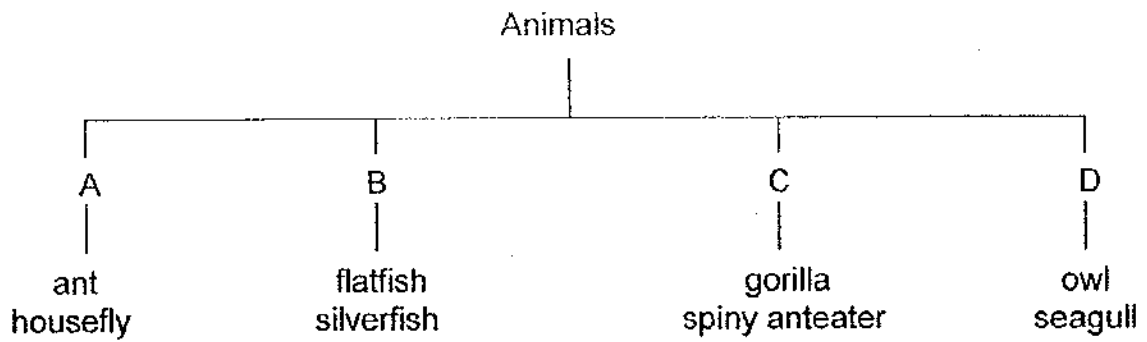

(a) One animal in the diagram has been classified wrongly. Name the animal. [1]

(b) In which should group (A, B, C or D) should the animal named in part (a) be classified? [1]

34 Bala set up the experiment as shown in the diagram below. He used a stopwatch to measure the time taken for the water to pass through each type of soil.

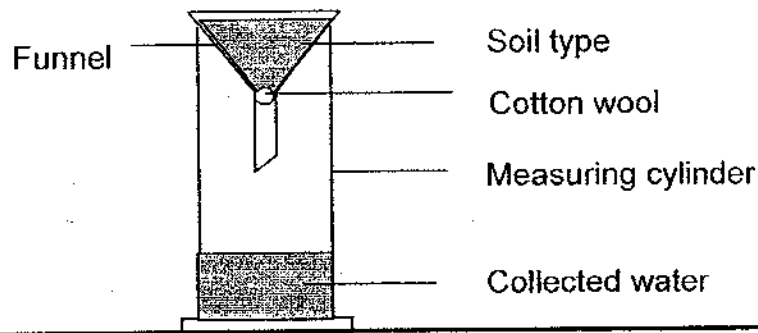

Soil Type	D	E	F	G	H
Time taken (seconds)	88	10	45	60	30

(a) What was he trying to find out? [1]

(b) In which type of soil would he find cacti growing in? [1]

35 The diagram below shows a food web.

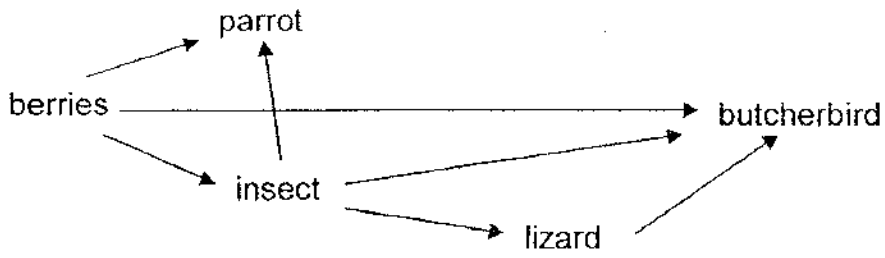

The graph below shows how the numbers of each of these animals varied between one year and the next.

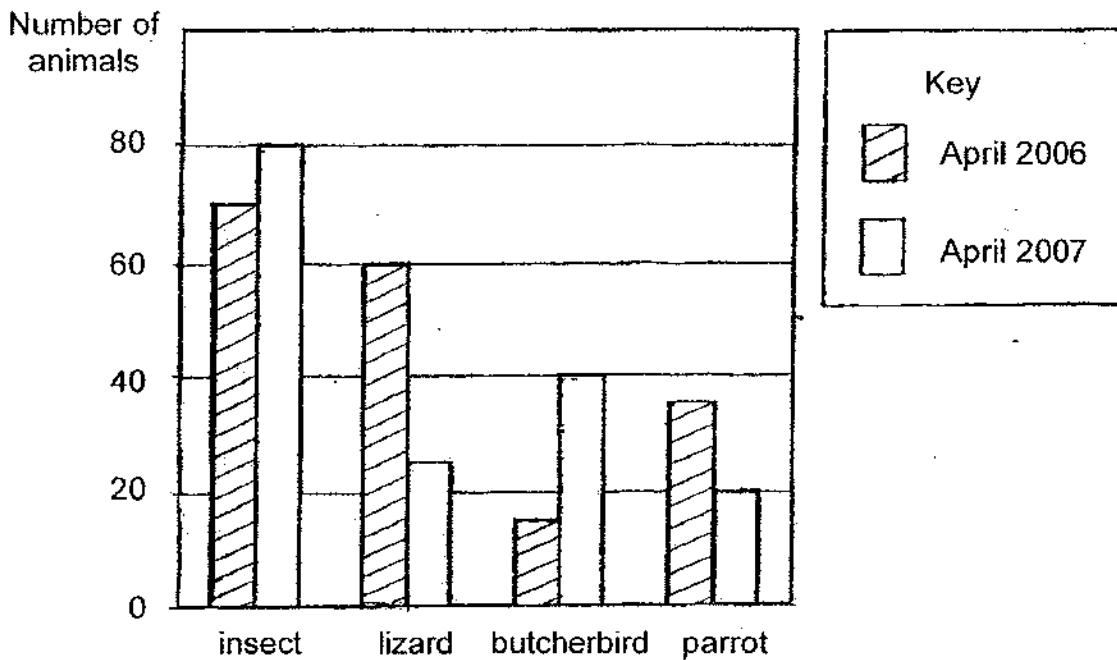

Based on the given information in the graph, there is an increase in the number of butcherbirds. Give two likely reasons for the increase in number of insects. [2]

Reason 1: _____

Reason 2: _____

36 In the classification of living things, scientists use keys such as a branching key to identify them. A key has a number of questions. The five animals, snail, earthworm, spider, wasp and housefly shown below have been identified using the branching key.

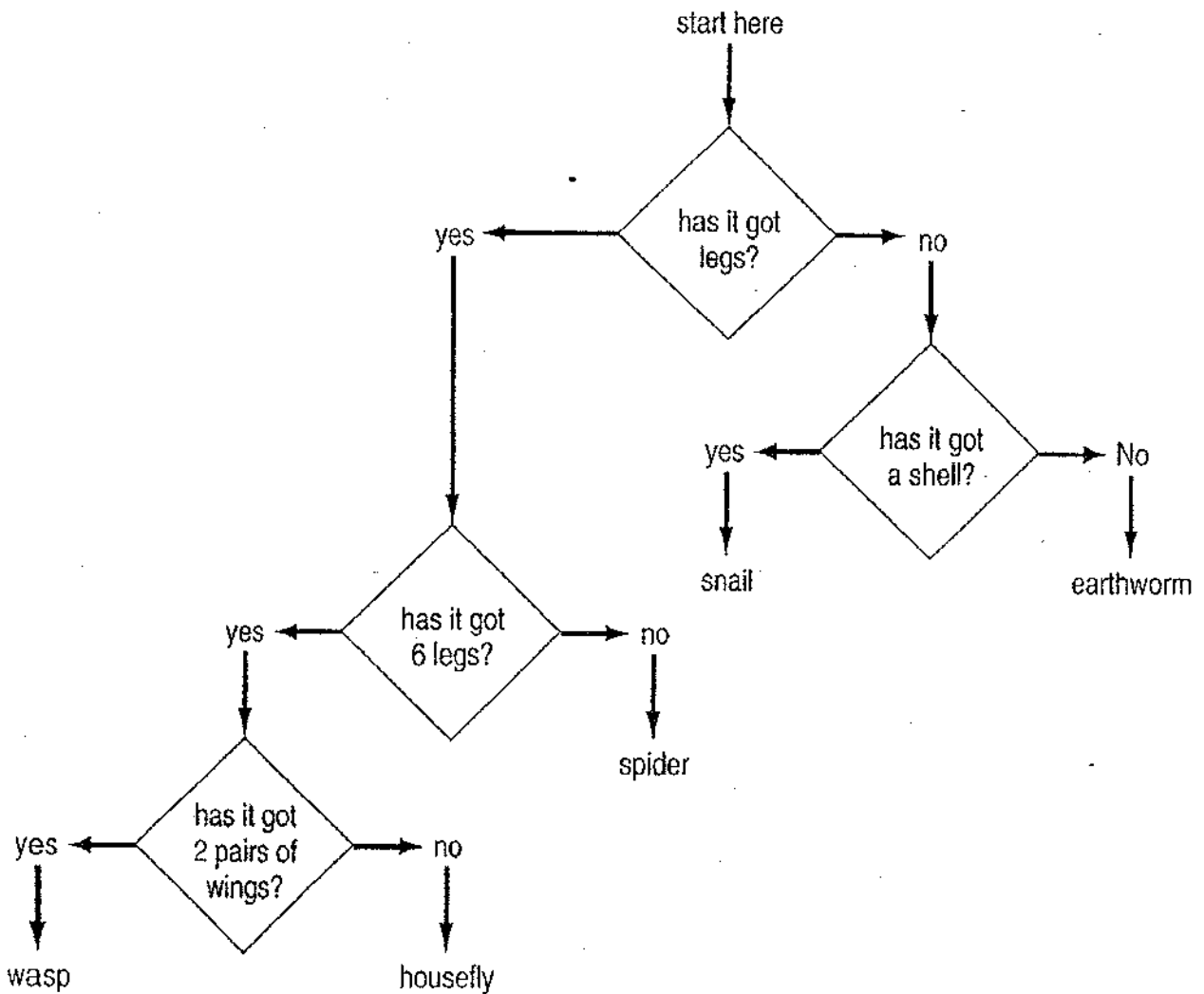
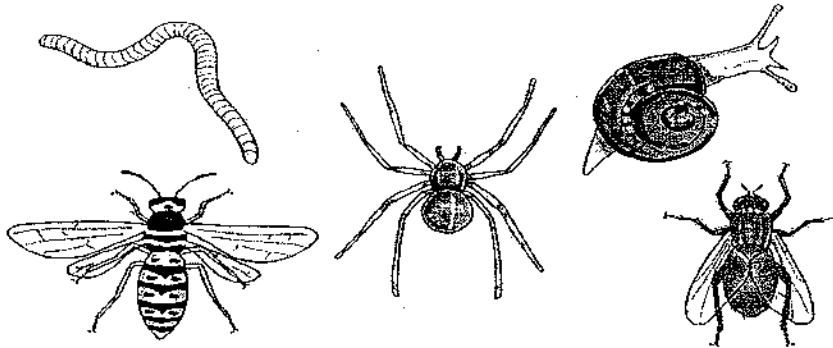

A scientist visited a desert island and discovered some organisms. She made some drawings and took them back to the laboratory. In the diagram below are the sketches.

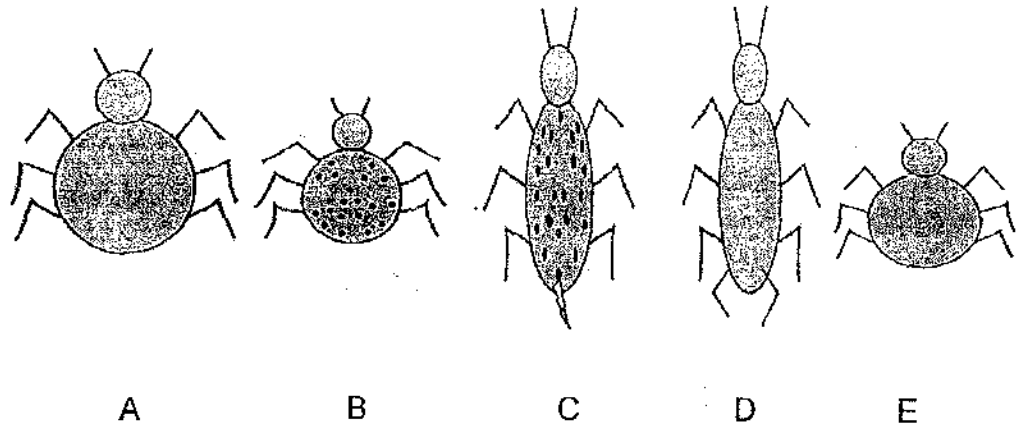

In the space below, make up a branching key to identify the organisms.

3
[2]

A large empty rectangular box provided for the student to write a branching key to identify the organisms.

37 The graph below shows the data collected from a lake over a time period of twelve months.

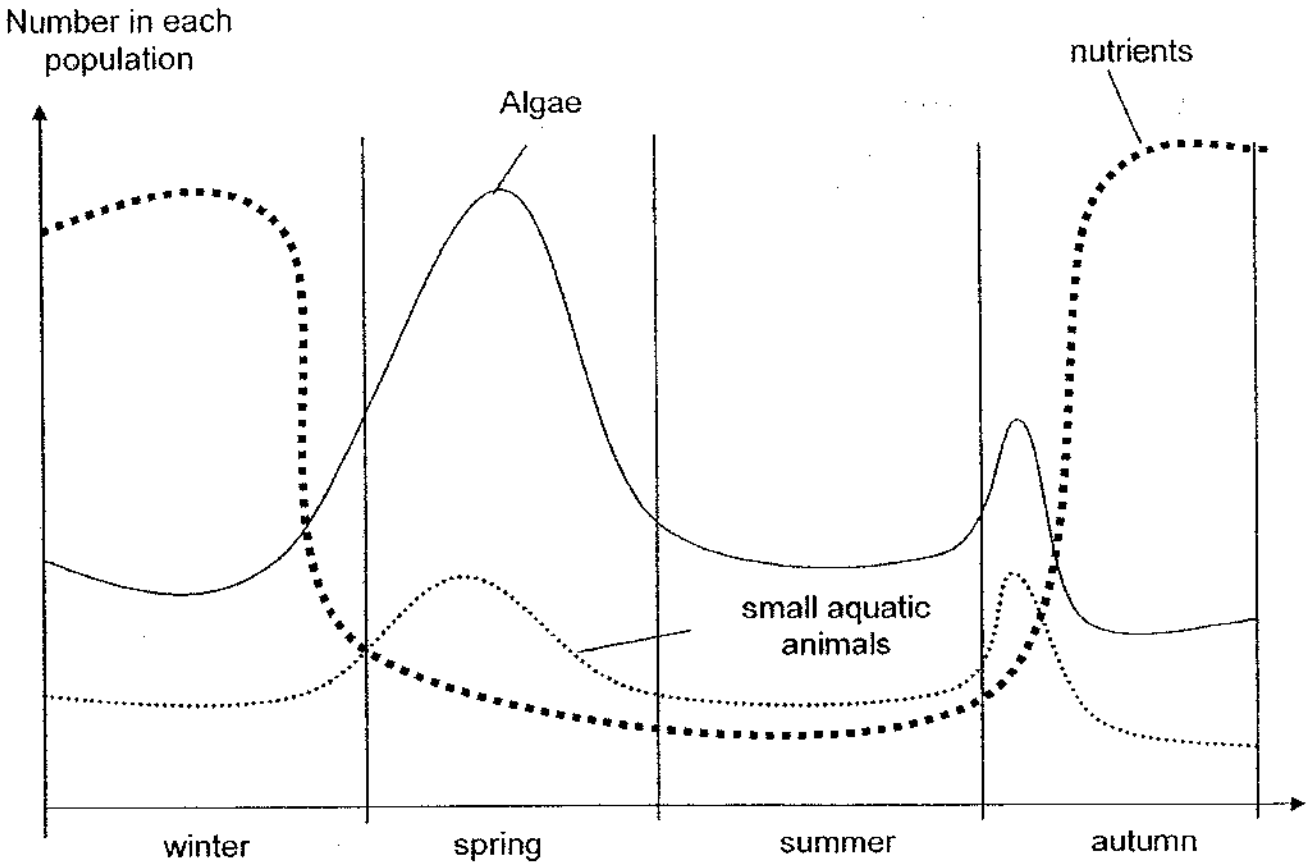

(a) Based on the graph, what is one possible physical factor that affects the growth of algae. [1]

(b) What is the relationship between amount of nutrients and the amount of algae? [1]

(c) How does the amount of algae affect the number of aquatic animals in the lake? [1]

38 Jimmy wanted to test his hypothesis that the presence of water plants increases the survival of guppies. He has been given the following items.

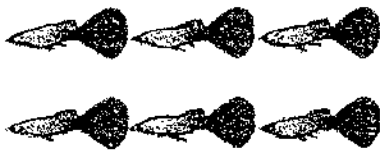

six
four guppies



six backswimmers



six strands of hydrilla

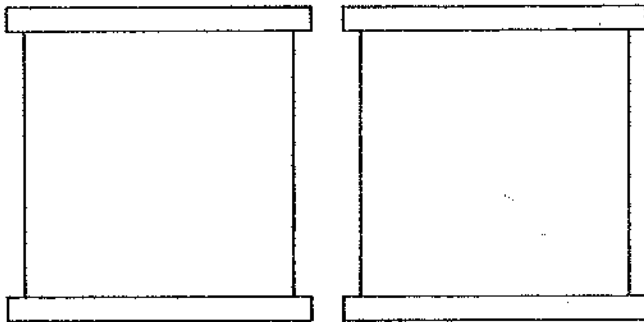

two air tight glass jars

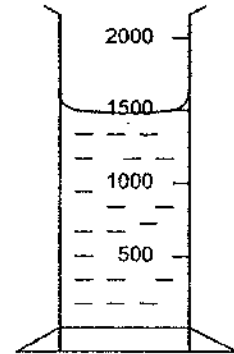

1500 ml of water

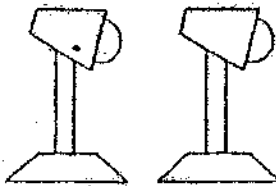

40 watts
table lamps

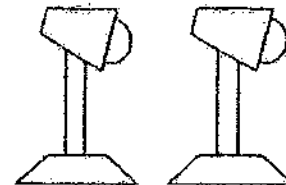

20 watts
table lamps

(a) John needs to prepare two set-ups to conduct a fair test. Complete the drawings to show the set-ups he should use. [2]

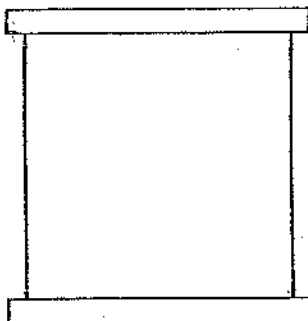

Set-up A

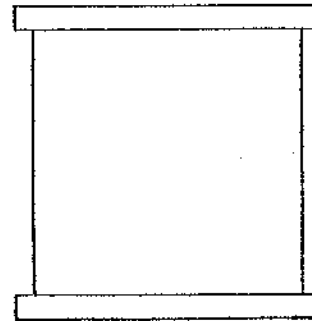

Set-up B

(b) What observation would prove that Jimmy's hypothesis is true? [2]

104

39 The diagram below shows the path taken by a swimmer after jumping off a diving board.

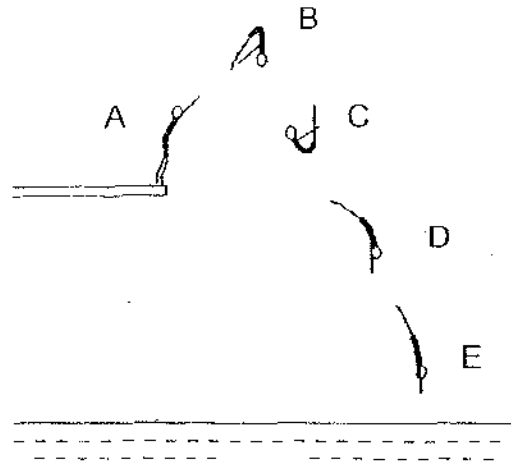

(a) State at which point A, B, C, D or E is kinetic energy the lowest? [1]

(b) Explain your answer in (a) [1]

40 The diagram below shows a simple compass made by a pupil.

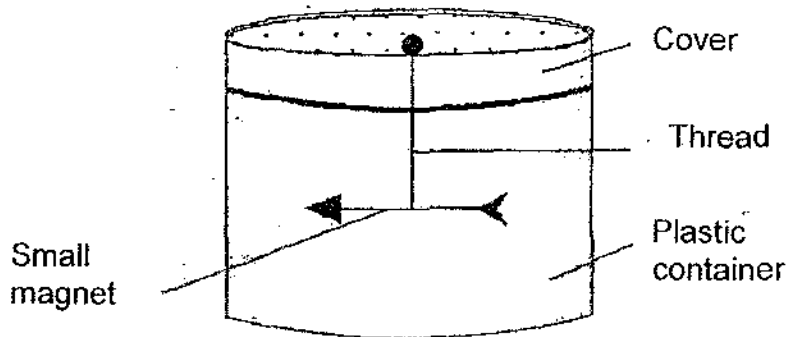

(a) Besides plastic, what other type of container can be used? [1]
suitable material can the container be made from?

(b) Give another reason why a transparent plastic cover is used. [1]

41 A group of children tested this idea of "The higher the height from where objects are dropped, the faster they fall", using four identical balls made from plasticine.

The diagram below shows the different heights the balls were dropped from and the effect on the shape of the plasticine balls after they landed on the ground.

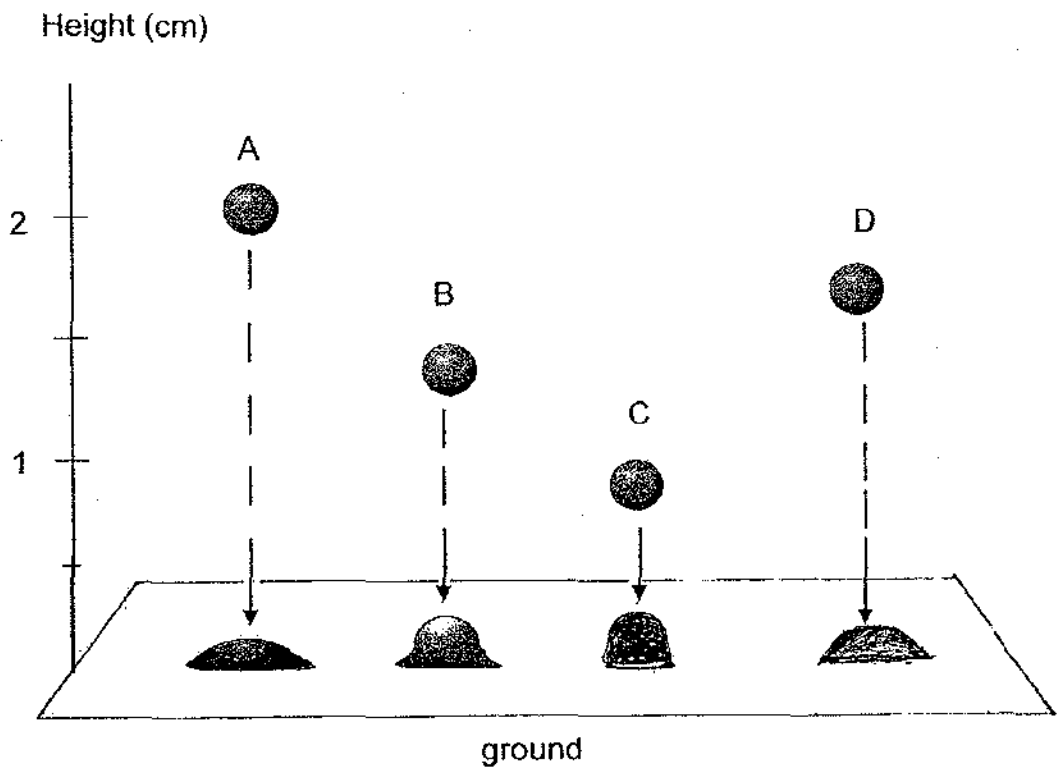

(a) Which plasticine ball was travelling the fastest? [1]

(b) What observation did the children use to compare the speeds of the four balls? [1]

- 42 A barrel is pulled up onto the back of a lorry using an electric motor as shown in the diagram below.

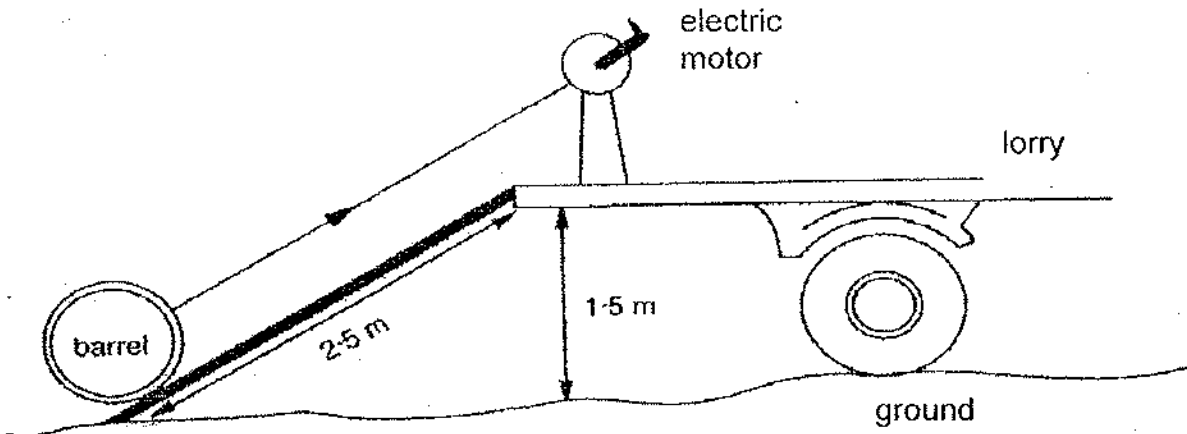

What are the forces acting on the barrel?

[2]

- 43 The diagram below shows a spring hanging from the ceiling.

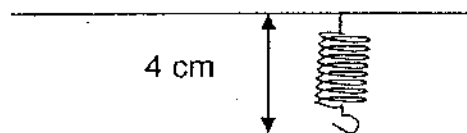

The table below shows the length of the spring when four objects A, B, C and D are hung on it.

Object	Length of spring (cm)
A	8
B	14
C	10
D	6

- (a) Which of the objects would give the deepest dent on a box of sand when all the objects are dropped from the same height?

[1]

- (b) Explain your answer in (a)

[2]

44 During a Science lesson, Gary learnt that friction occurs when a moving object is in contact with another.

He carried out an experiment using the set-up shown below. The wooden block is placed with its broader surface on the table. Then, he pulled the wooden block across three different surfaces and measured the force used each time.

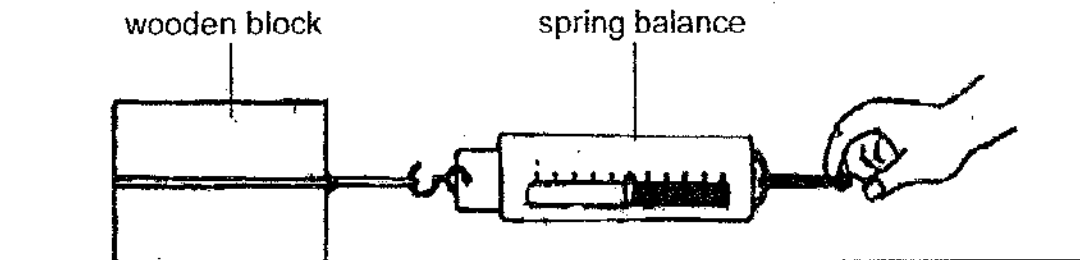

He tabulated the results of the experiment:

Type of surface	Reading of the spring balance (kgf)
Across the table	2.5
Across the sandpaper	4.5
Across the glass plate	1.5

(a) From the results, what is the relationship between the type of surface and the amount of force used to pull the wooden block? [1]

In another experiment, Gary placed the wooden block with its narrower surface on the table. Then, he pulled the wooden block across the three different surfaces as in the first experiment. Again, he measured the force used each time. The same results were obtained.

(b) What conclusion can be made from the results of both experiments? [1]

- 45 The diagram below shows an electric circuit with the insulated copper wire wound around two identical iron nails.

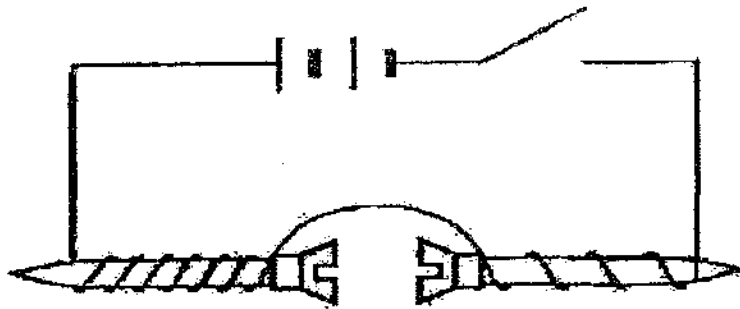

When the switch is closed, explain what happens to the nails?

[2]

- 46 The diagram below shows a method used for keeping food warm overnight. In the evening the food is heated in the metal pot. The pot is then placed in the wooden box and the pot is surrounded by loosely packed pebbles.

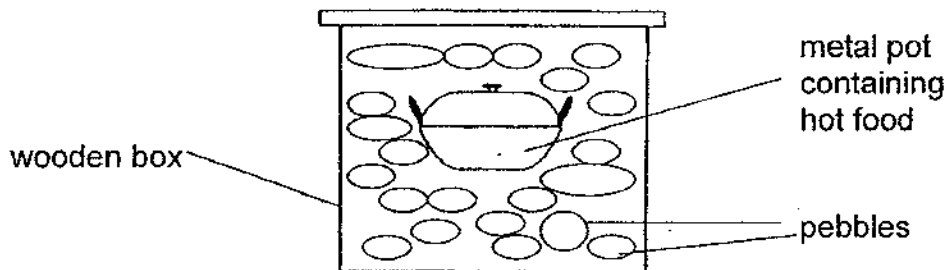

(a) Explain how the loosely packed pebbles reduce the heat loss from the food.

[2]

(b) Explain what is likely to happen if the pebbles in the wooden box are tightly packed.

[2]

End of Paper

ANSWER SHEET

EXAM PAPER 2009

**SCHOOL : PEI HWA PRIMARY
SUBJECT : PRIMARY 6 SCIENCE**

TERM : SA1

Q1	Q2	Q3	Q4	Q5	Q6	Q7	Q8	Q9	Q10	Q11	Q12	Q13	Q14	Q15	Q16	Q17
3	3	4	1	4	2	1	3	2	3	3	1	1	4	4	4	3

Q18	Q19	Q20	Q21	Q22	Q23	Q24	Q25	Q26	Q27	Q28	Q29	Q30
4	1	2	1	4	4	1	2	2	1	2	3	2

31)a)The insecticide kills the flies and caterpillars first leaving the mice with more food.

b)When the flies and caterpillars die, the sparrows have no food so the number of sparrows decrease. The sparrowhawks feed only on sparrows so the number of sparrowhawks decrease too. However the snakes can still feed on mice so the decrease in the number of snakes is smaller than the decrease in the number of sparrowhawks.

32)a)Photosynthesis.

b)During photosynthesis, carbon dioxide is taken in and oxygen is produced which is used by the ants during breathing. It also provides the ants with food.

33)a)Silverfish.

b)Group A.

34)a)He was trying to find out which type of soil allows water to pass through most easily.

b)E.

35) 1) There is a decrease in the number of parrots so the insects have fewer predators.

2) There is a decrease in the number of lizards so the insects, have fewer predators.

36)

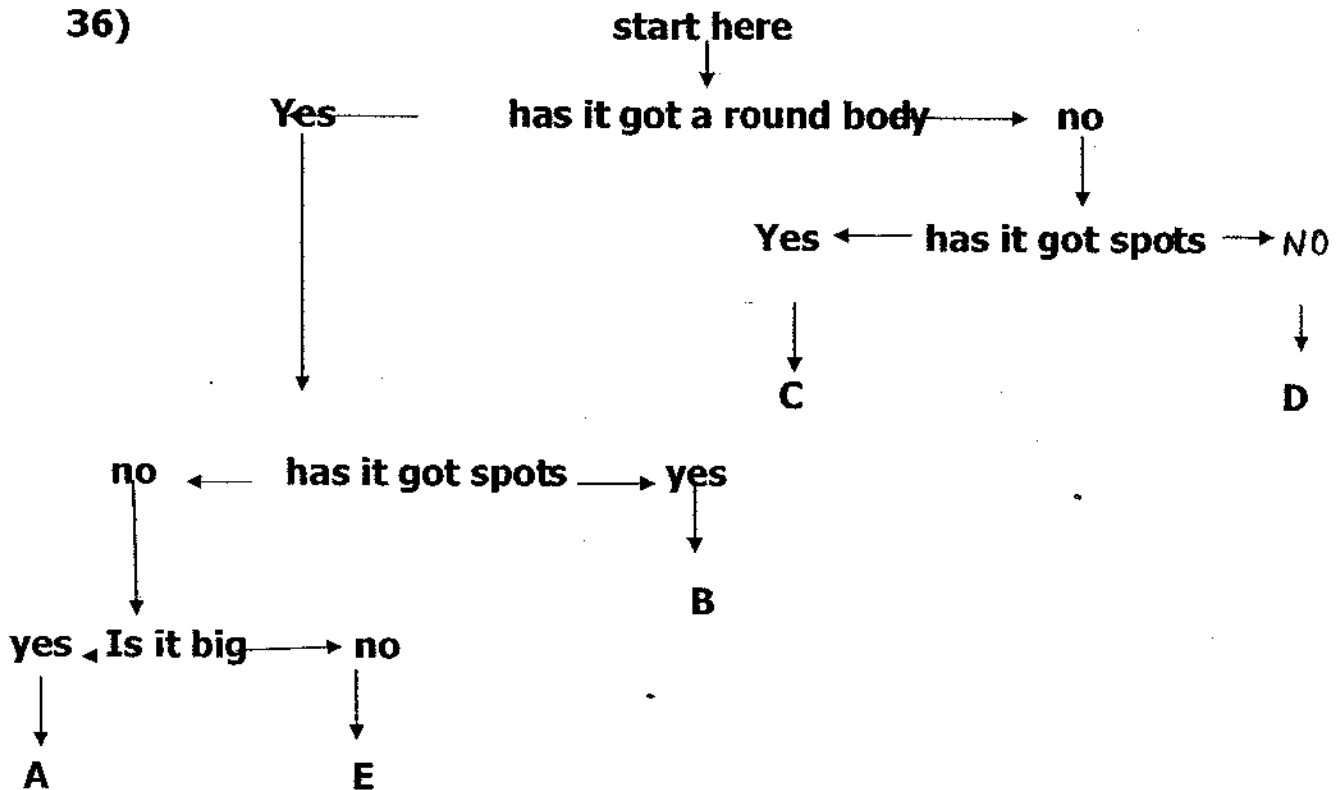

37) a) Temperature .

b) As the amount of nutrients decrease, the amount of algae increase.

c) As the amount of algae increases the number of aquatic animal in the lake also increases.

38) a)

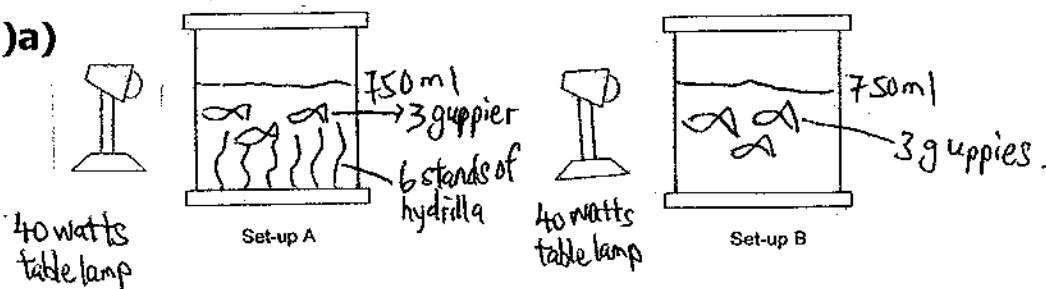

b) All the guppies in set-up A are still alive but some of the guppies in set-up B

39)a)B

b)At B, the swimmer is at its highest point so it has the greatest potential energy and kinetic energy is the lowest.

40)a)Rubber.

b)Light can pass through the transparent plastic cover so the user can see the direction of the small magnet.

41)a)A

b)The shape of the plasticine balls was used to compare the speeds. The flatter the plasticine balls, the greater is the speed of the ball.

42)Pulling force of electric motor and frictional force.

43)a)B.

b)B has the greatest length of spring so it has the greatest mass. When all the object are dropped from the same height, B will have the greatest potential energy, hence it would give the deepest dent on a box of sand.

44)a)The rougher the surface, the greater is the amount of force used to pull the wooden block.

b)The amount of force used to pull the wooden block depends on the type of surface but it does not depend on the area of the surface.

45)Both nails will be magnetised and they become electromagnets.

46)a)The loosely packed pebbles have air trapped in between them and air is a bad conductor of heat which helps to reduce the heat loss from the food.

b)There is less air spaces and heat will be conducted away faster.