



**CATHOLIC HIGH SCHOOL
PRIMARY 5
MID-YEAR EXAMINATION 2009**

**SCIENCE
EM 1 / EM 2**

Name: _____ ()

Class : Primary 5 _____

Date : 18 May 2009

BOOKLET A

30 Questions
60 Marks

Total Time for Booklets A & B : 1 hour 45 minutes

Instructions to Candidates

Do not open this booklet until you are told to do so.
Follow all instructions carefully.
Answer all questions.

Section A: Multiple Choice Questions (60 marks)

For each question from 1 to 30, four options are given. One of them is the most suitable answer. Make your choice (1, 2, 3 or 4). Shade the correct oval (1, 2, 3 or 4) on the Optical Answer Sheet.

1. The diagram below shows an insect.

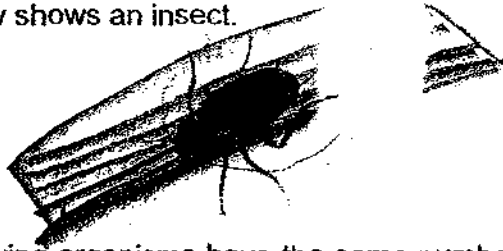

Which of the following organisms have the same number of stages in their life cycles as the insect above?



Organism A



Organism B



Organism C



Organism D



Organism E



Organism F

- (1) E and F only
- (2) C, E and F only
- (3) A, B, C and D only
- (4) C, D, E and F only

2. Look at the classification chart below carefully.

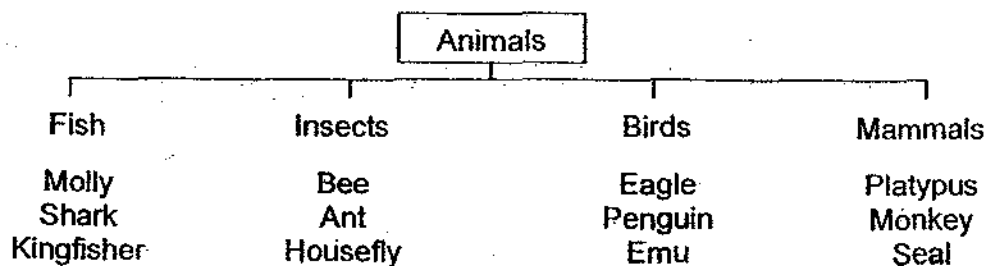

Which animal has been wrongly classified?

- (1) Shark
- (2) Penguin
- (3) Platypus
- (4) Kingfisher

3. The diagrams below show different plants and their plant parts labelled X, Y and Z.

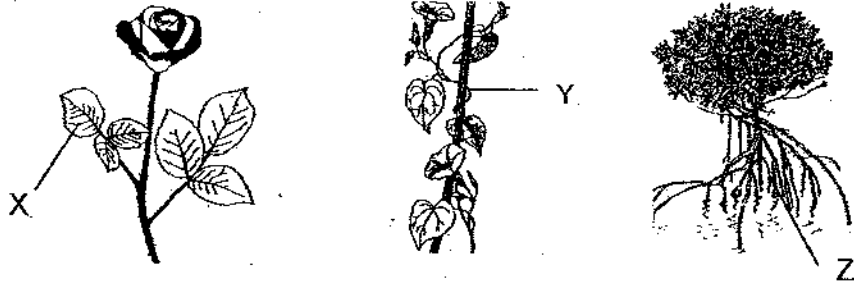

Which one of the following matches the plant parts X, Y and Z to their functions accurately?

	Make food for the plant	Cling to a support	Absorb water
(1)	X	Y	Z
(2)	Y	X	Z
(3)	Y	Z	X
(4)	Z	Y	X

4. Which of the following organisms does not reproduce from spores?

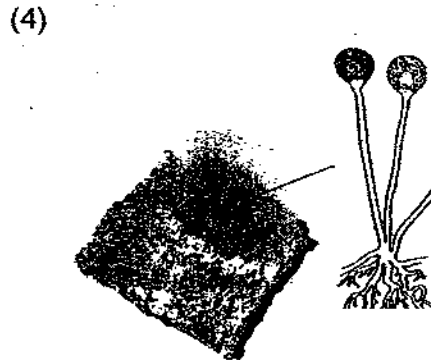

5. The diagram below shows part of the human digestive system.

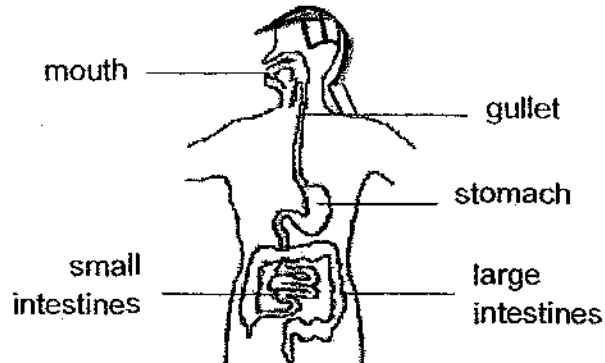

Which of the following parts in the digestive system produces digestive juices?

	Mouth	Gullet	Stomach	Small intestines	Large intestines
(1)	✓	✓			
(2)	✓	✓	✓		
(3)			✓	✓	✓
(4)	✓		✓	✓	

6. Study the cell diagram below carefully.

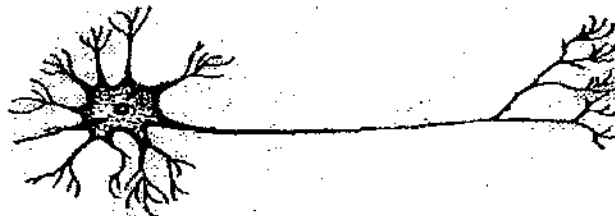

Which of the following is definitely true about the cell shown?

- (1) It does not have a cell membrane.
- (2) It is found in a uni-cellular organism.
- (3) It contains a green pigment called chlorophyll.
- (4) It is an animal cell as it does not have a cell wall.

7. Sean put some pebbles, goldfish, guppies and plastic plants into an aquarium. He counted the number of each item every five weeks and recorded it in the table below.

Items	Week 0	Week 5	Week 10	Week 15	Week 20
Pebbles	20	20	20	20	20
Goldfish	24	25	25	27	28
Guppies	18	18	21	24	25
Plastic plants	10	10	10	10	10

What can Sean conclude from this experiment?

- (1) Only living things can grow.
 - (2) Only living things need food.
 - (3) Only living things can reproduce.
 - (4) Only living things can make food.
8. Sammy cut out a shape from a piece of black-coloured paper and attached it to a leaf of a plant. He left the plant in the sun and watered it regularly.

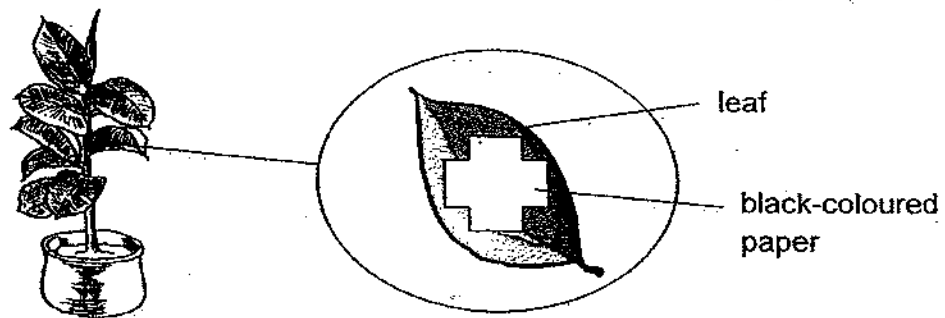

After three days, Sammy removed the leaf and tested it for starch. Which of the following shows his result of the test?

- (1) dark blue colour
- (2) yellowish brown colour
- (3) yellowish brown colour
dark blue colour
- (4) dark blue colour
yellowish brown colour

9. Jamie placed three similar pots of plant at the same location and observed them over 30 days. She recorded her observations in the table below.

Variables	Pot K	Pot L	Pot M
Original height of plant/ cm	12	18	23
Amount of water given to the plant daily/ ml	100	100	100
Amount of fertiliser added every 3 days/ mg	2	5	7
Height of plant on day 30/ cm	21	30	30

Based on Jamie's observations, which of the following is true?

- (1) Plants need water to grow.
 - (2) Plants grow better with fertilisers.
 - (3) The more fertilisers added, the better the plant grows.
 - (4) The amount of fertilisers added to the plant affects its growth.
10. Lisa found three leaves in the garden.



Leaf D



Leaf E



Leaf F

Based on the pictures above, what is a similarity between the leaves?

- (1) They have smooth edges.
 - (2) They have the same shape.
 - (3) They are variegated leaves.
 - (4) They can carry out photosynthesis.
11. Which of the flowers is unable to develop into a fruit?

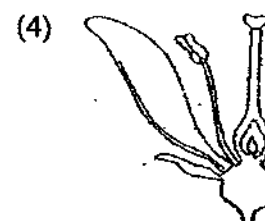
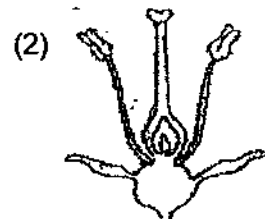
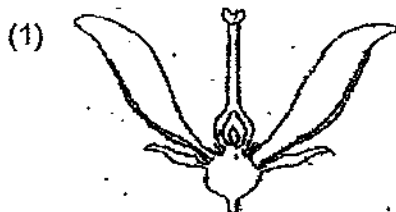

12. Kasim had 4 beakers containing 10 similar seeds each. He left 2 beakers in the cupboard in a room and another 2 beakers on the table in the same room. Five days later, he observed if the seeds in the beakers had germinated.

Beakers	Moisture condition	Light condition
G	dry	bright
H	dry	dark
I	moist	bright
J	moist	dark

Which of the beakers will contain seeds that have germinated?

- (1) G and I only
 - (2) I and J only
 - (3) G, I and J only
 - (4) G, H and J only
13. Zoe sprained her ankle while playing basketball. Which function(s) of the bone would she lose for some time?



- A Protecting her organs
 - B Giving shape to her leg
 - C Supporting her body mass
 - D Working with the muscles to move her feet freely
- (1) D only
 - (2) A and B only
 - (3) C and D only
 - (4) B, C and D only

14. Janet conducted an iodine test on four food samples. The table below shows the results of her test.

Food sample	Results
A	iodine turned dark blue
B	iodine turned dark blue
C	no change in iodine
D	no change in iodine

Based on Janet's observations, which of the following items matches the food sample with the results?

(1)	A	raw meat
(2)	B	mushroom
(3)	C	mashed potato
(4)	D	steamed prawns

15. Xiaoping wants to find out if carbon dioxide is needed for plants to photosynthesise. She sets up the experiment with two glass containers and two similar plants.

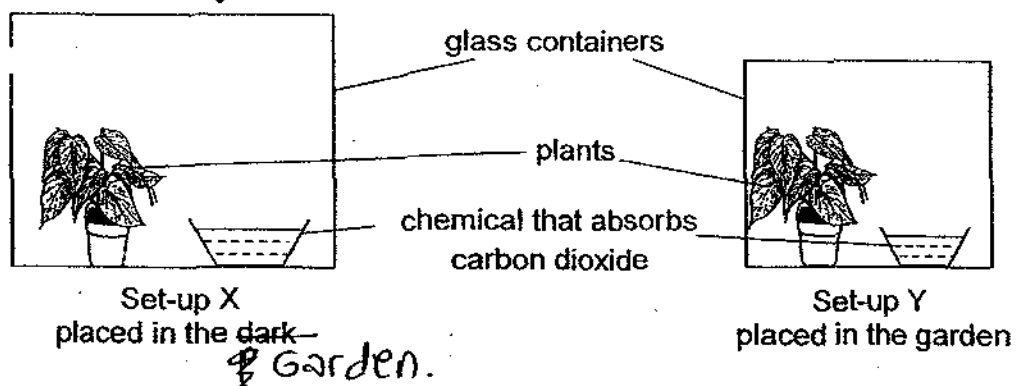

Xiaoping's teacher observed that the experiment set-up was not a fair one. What should Xiaoping do to make her experiment a fair test?

- A Place Set-up Y in the dark.
 - B Use containers of the same size.
 - C Seal up the container in Set-up X.
 - D Remove the chemical that absorbs carbon dioxide from one set-up.
- (1) B only
 - (2) A and D only
 - (3) A, B and C only
 - (4) B, C and D only

16. Study the flowchart that shows the characteristics of animals.

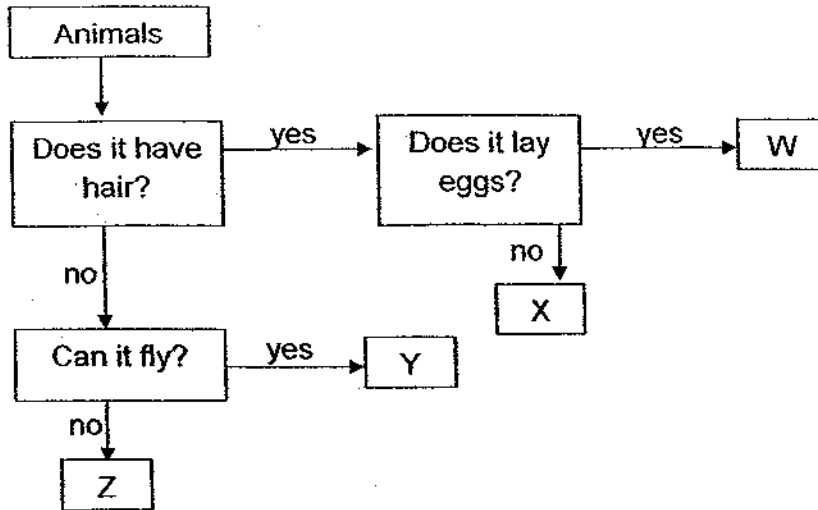

Which animals are best represented by W, X, Y and Z?

	Animal W	Animal X	Animal Y	Animal Z
(1)	platypus	whale	penguin	shark
(2)	penguin	elephant	seagull	platypus
(3)	platypus	shark	ostrich	penguin
(4)	spiny anteater	elephant	sparrow	penguin

17. Renyi wanted to find out if living things can grow. The diagram below shows his experimental set-up, which he left in an open field.

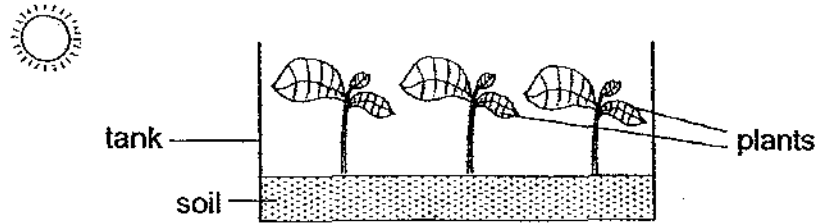

He watered the plants regularly and measured and recorded the height of each plant every 10 days. Which of the following could he use as a control set-up for his experiment?

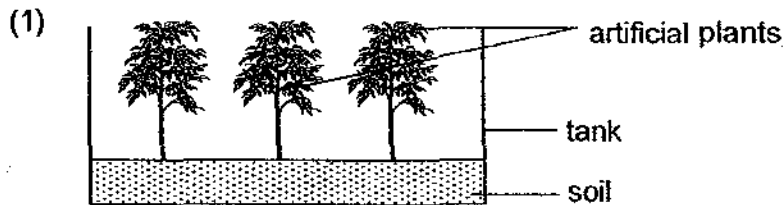

Condition: Set-up is left in the same open field

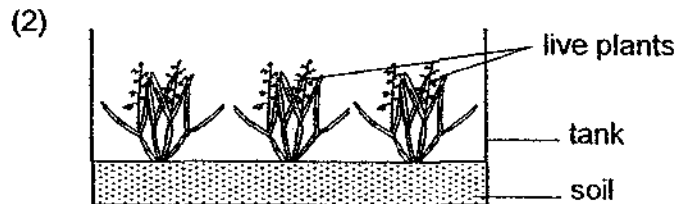

Condition: Plants are not watered during the experiment

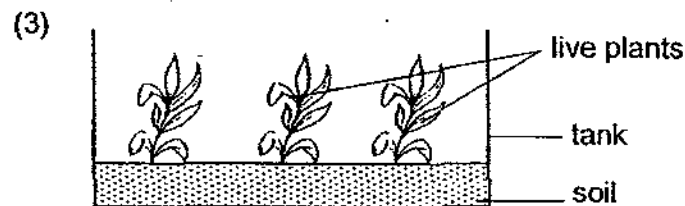

Condition: Set-up is left in the same open field

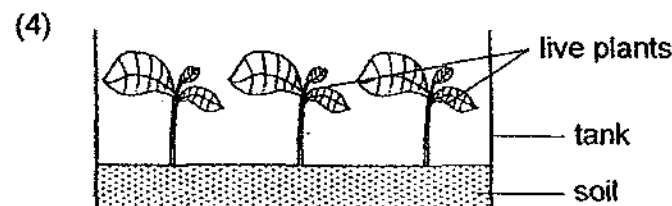

Condition: Set-up is left in a dark cupboard

18. Study the diagrams below. "X" marks the position Paul is standing at. In which of the following will Paul be able to see the ball reflected in the mirror from where he is standing?

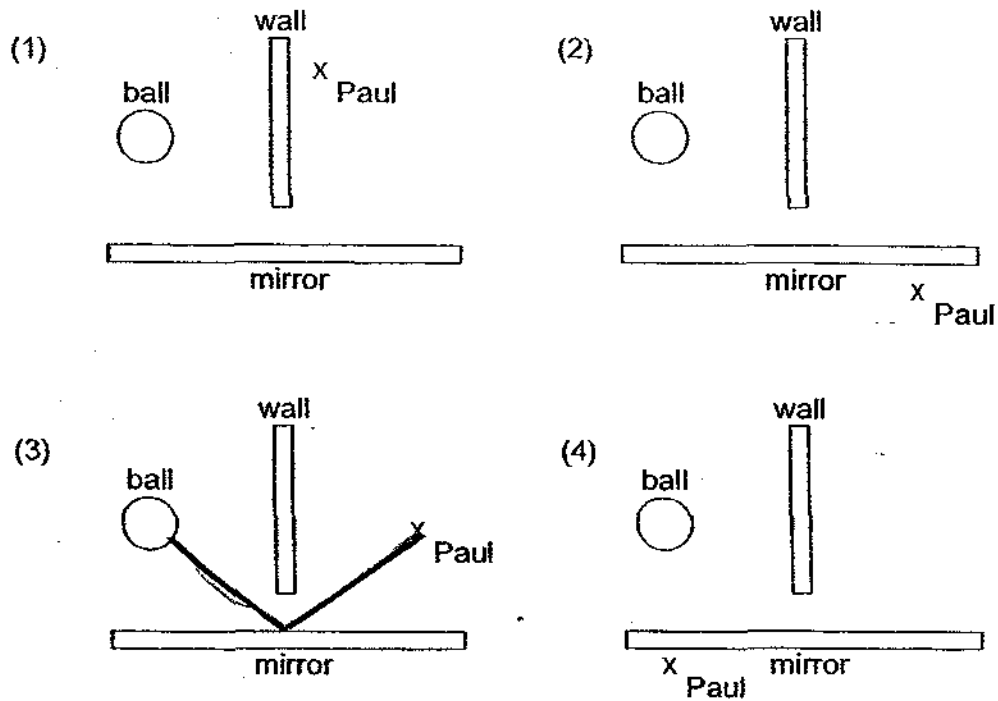

19. The set-up below shows two identical balloons containing the same amount of air, hanging on a balance. Two erasers are placed into one of the balloons before inflating it.

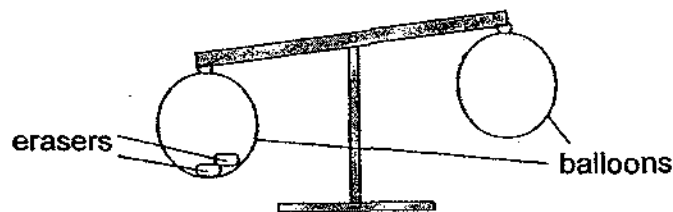

What does this set-up show?

- (1) Air takes up space.
- (2) Erasers have mass.
- (3) Balloons have mass
- (4) Air takes the shape of its container.

20. Several cubes of ice were added to a beaker of water and left on a table for half an hour.

Which of the following shows the correct heat gain and heat loss taking place in the ice cubes, water and beaker during this experiment?

	Ice cubes	Water	Beaker
(1)	heat loss	heat gain	heat gain
(2)	heat gain	heat loss	heat gain
(3)	heat gain	heat loss	heat loss
(4)	heat loss	heat gain	heat loss

21. Which of the following does not contribute to conserving our Earth's supply of natural resources?

- (1) Use energy-saving bulbs.
- (2) All vehicles to use natural gas instead of petrol.
- (3) Only turn on the water heater before showering.
- (4) Ensure that the refrigerator is overloaded with food.

22. An air pump that can contain up to 500 cm^3 of air is connected to a container of a capacity of 1500 cm^3 .

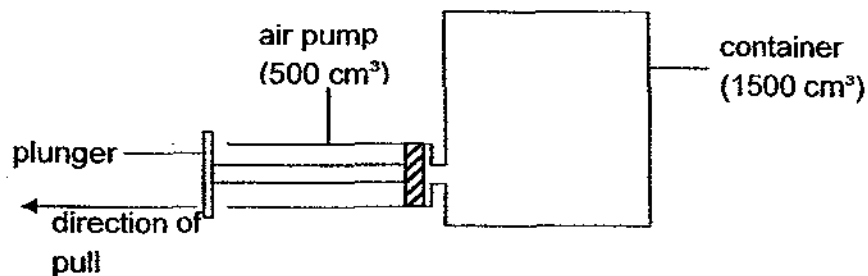

When the plunger was pulled, air from the container flowed into the air pump and filled it completely.

What was the final volume of air in the container?

- (1) 1000 cm^3
- (2) 1500 cm^3
- (3) 2000 cm^3
- (4) 3000 cm^3

23. The physical properties of five different materials, M, N, O, P and Q, are shown in the table below.

Material	Is it flexible?	Is it durable?	Is it waterproof?	Is it strong?	Does it allow light to pass through?
M	a little	yes	no	no	yes
N	yes	yes	yes	yes	no
O	no	yes	no	yes	a little
P	yes	no	yes	no	yes
Q	no	yes	yes	yes	yes

Which combination of materials is most suitable to make a magnifying glass?

	Handle and frame	Lens
(1)	N	M
(2)	O	P
(3)	Q	M
(4)	N	Q

24. Kevin prepared four set-ups as shown. The electrical wires, batteries and iron nails used were identical.

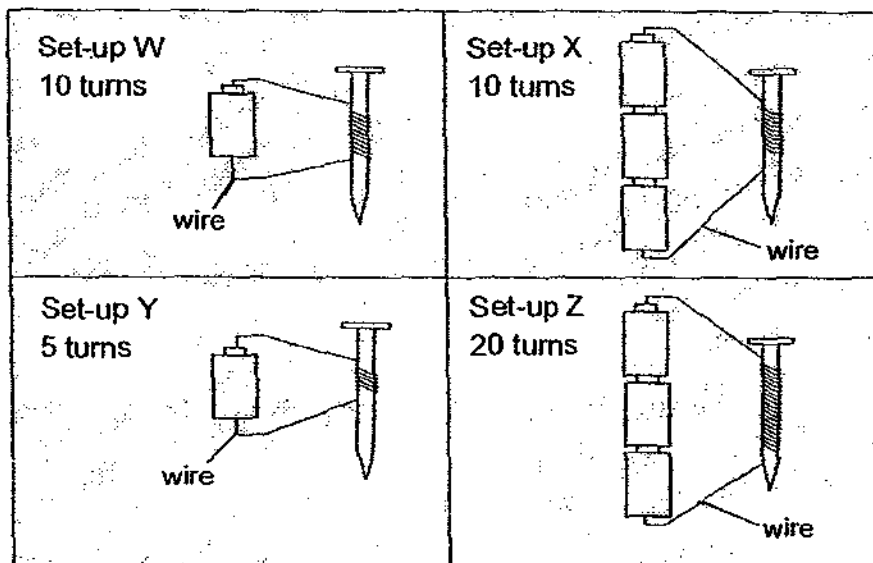

He compared the strength of all four electromagnets he made and arranged them from the weakest to the strongest. Which of the following arrangement did Kevin most likely get?

- (1) W, X, Y, Z
- (2) Y, W, X, Z
- (3) Y, W, Z, X
- (4) Z, X, W, Y

25. Five solids made of different materials were set up in an experiment as shown. An identical iron nail was placed on the surface of each solid, supported by the same mass of plasticine.

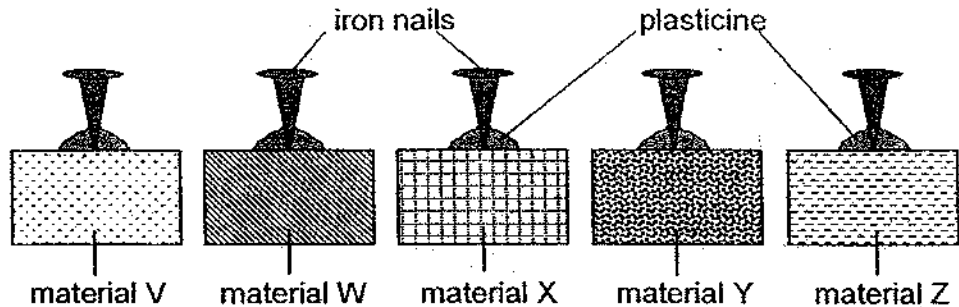

A weight of mass 2 kg was dropped onto each nail from the same height. The depth to which each nail was driven into each solid was recorded in the table below.

Material	Depth/ mm
V	9
W	5
X	13
Y	20
Z	18

From the results above, which of the following is/are true?

- A Material Y is the softest material.
 - B Material Z is harder than material X.
 - C Material W is harder than material V.
 - D All five materials are softer than iron.
- (1) A only
(2) A and C only
(3) B and D only
(4) A, C and D only

26. Sam designed a game, which is played by using a magnet to attract a toy car from the start to the finish line.

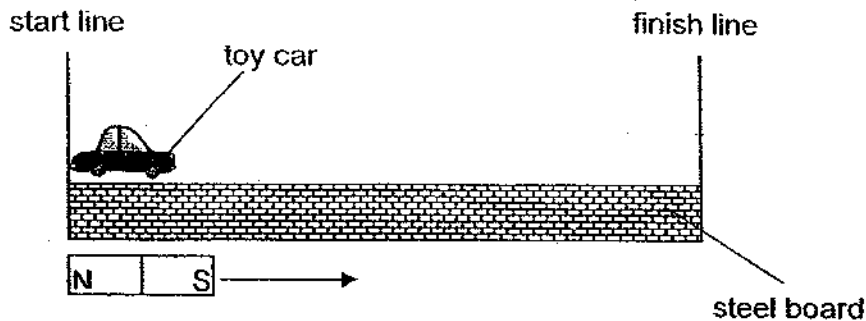

Sam found that the toy did not move when he moved the magnet in the direction shown. What should Sam do to make his game work?

- (1) Use a thinner board made of aluminium.
 - (2) Use a cobalt board instead of a steel board.
 - (3) Use a stronger magnet to attract the toy car.
 - (4) Use only one of the magnet's poles to attract the toy car.
27. Four beakers, P, Q, R and S, made of different materials are filled with pure water and heated to boiling point using similar heat sources.

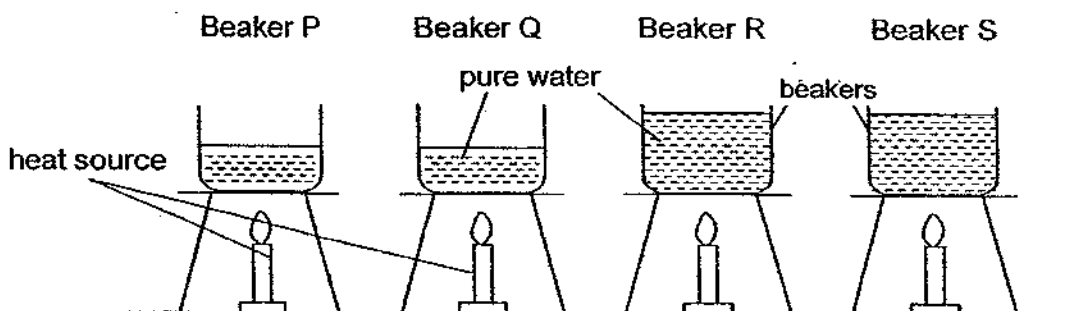

The table below shows the duration for the water in each beaker to reach boiling point.

Beaker	Time/ min
P	11
Q	6
R	20
S	12

Which of the following shows the most reasonable material for each set-up?

- (1)

Material P	Material Q	Material R	Material S
Iron	Wood	Aluminium	Glass
- (2)

Material P	Material Q	Material R	Material S
Wood	Aluminium	Iron	Glass
- (3)

Material P	Material Q	Material R	Material S
Glass	Iron	Wood	Aluminium
- (4)

Material P	Material Q	Material R	Material S
Aluminium	Glass	Iron	Wood

28. Study the diagram below. The clear red plastic and the white screen are of the same size. The cardboard has the same width but has only half the height of the white screen.

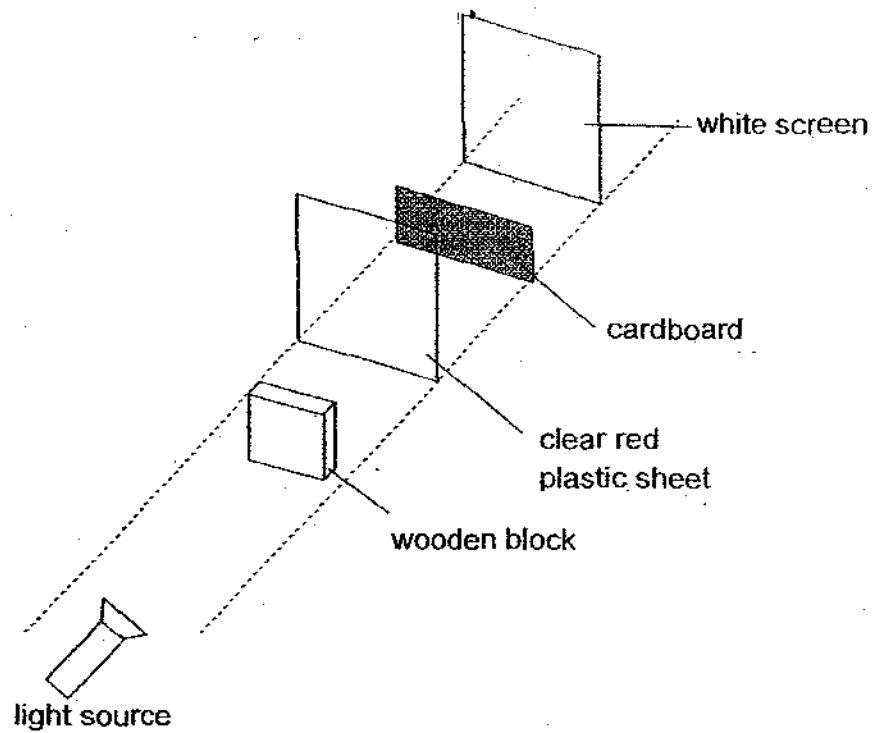

Based on the set-up, which of the following shows the shadow formed on the white screen?

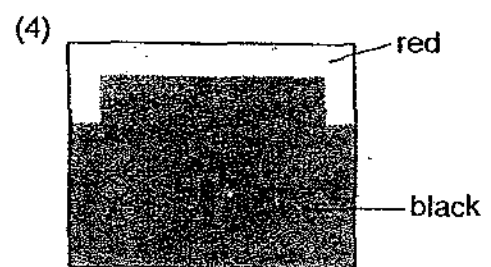
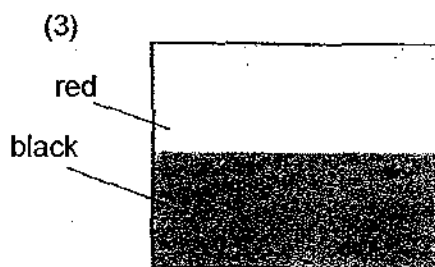
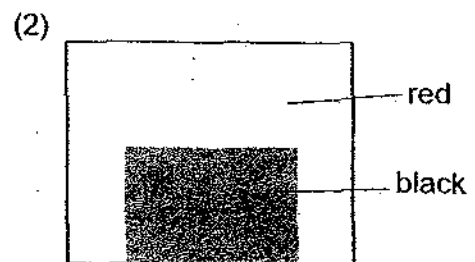
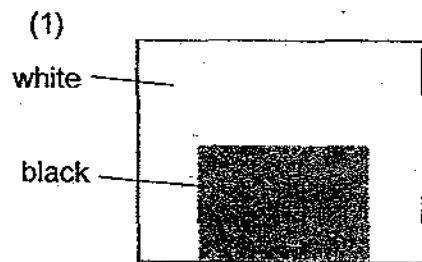

29. Mohan wanted to investigate how the number of bulbs in a circuit affects the brightness of the bulbs.

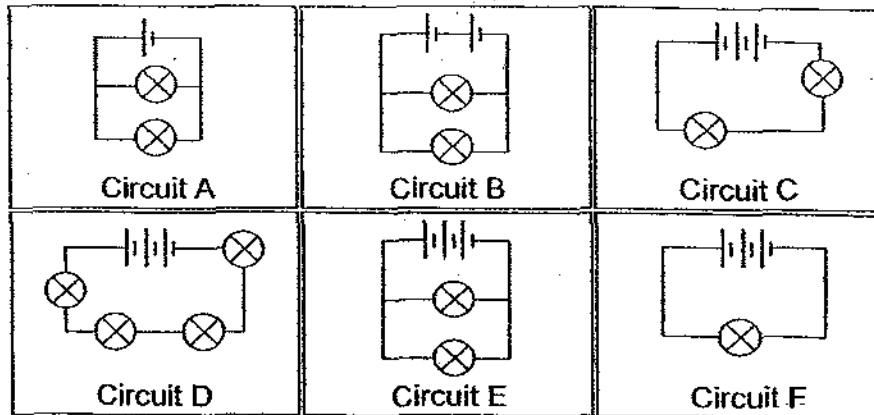

Which circuits should Mohan set up to carry out his investigation?

- (1) Circuits A and E only
 - (2) Circuits B and F only
 - (3) Circuits A, B and E only
 - (4) Circuits C, D and F only
30. Three objects, A, B and C, made of different materials were connected to an electrical circuit at positions 1 and 2. The results were recorded below.

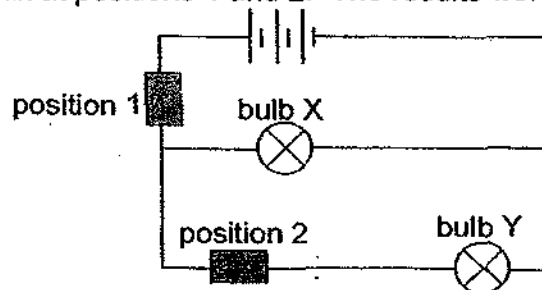

Object at position 1	Object at position 2	Does the bulb light up?	
		Bulb X	Bulb Y
A	B	Yes	Yes
B	C	Yes	No
A	C	Yes	No
C	A	No	No

Which object(s) is/are made of a material that conducts electricity?

- (1) A only
- (2) A and B only
- (3) B and C only
- (4) A, B and C

- End of Section A-



**CATHOLIC HIGH SCHOOL
PRIMARY 5
MID-YEAR EXAMINATION 2009**

**SCIENCE
EM 1 / EM 2**

Name: _____

Class : Primary 5 _____

Date : 18 May 2009

BOOKLET B

14 Questions
40 Marks

Total Time for Booklets A & B: 1 hour 45 minutes

Instructions to Candidates

Follow all instructions carefully.
Answer all questions.

Parent's Signature: _____

Date: _____

Score	
Section A	60
Section B	40
Total	100

Section B: Open-Ended Questions (40 marks)

Read the following questions carefully and write your answers in the space provided. The maximum marks that can be awarded is shown at the end of each question or part question.

31. The diagrams below show the life cycles of two different animals.

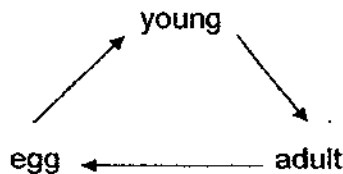

Penguin

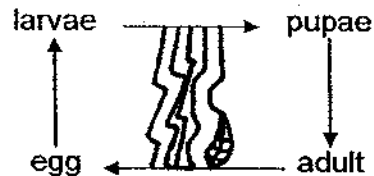

Mealworm Beetle

State one difference and one similarity between the life cycles of a Penguin and a Mealworm Beetle. [2]

Difference: _____

Similarity: _____

32. The table below shows a comparison between four cells, S, T, U and V.

Parts of a cell	Cell S	Cell T	Cell U	Cell V
nucleus	✓	✓	✓	x
cytoplasm	✓	✓	✓	✓
cell membrane	✓	✓	✓	✓
cell wall	x	✓	✓	x
chloroplast	x	✓	x	x

a) Based on the information given in the table, which cell can make food? Explain your answer. [2]

b) Which cell is most likely taken from an onion? [1]

33. Look at the human digestive system below.

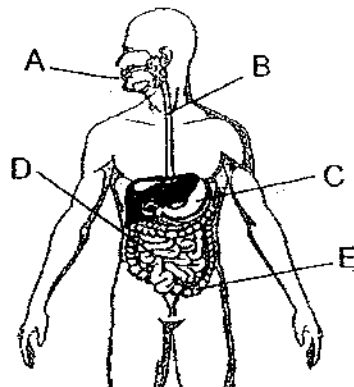

a) In which part of the digestive system, A to E, above is water absorbed into the body? [1]

b) In which part of the digestive system, A to E, above is food completely digested? [1]

34. The diagram below shows an experiment that was set up to investigate how salt affects the photosynthesis of plants.

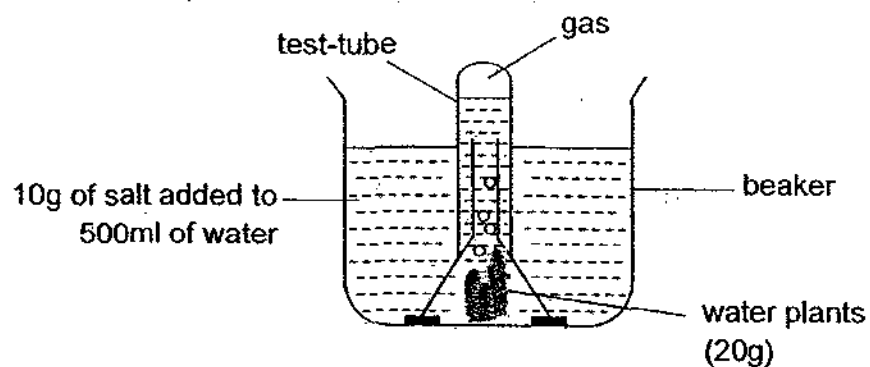

a) What is the gas produced in the test-tube? [1]

b) Complete the photosynthesis equation below. [1]

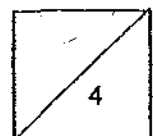
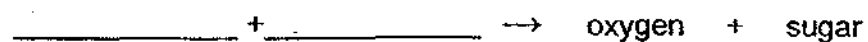

35. Kayden placed some seeds into Box J and a few seedlings into Box K. He put moist cotton into both boxes and sealed them up completely as shown.

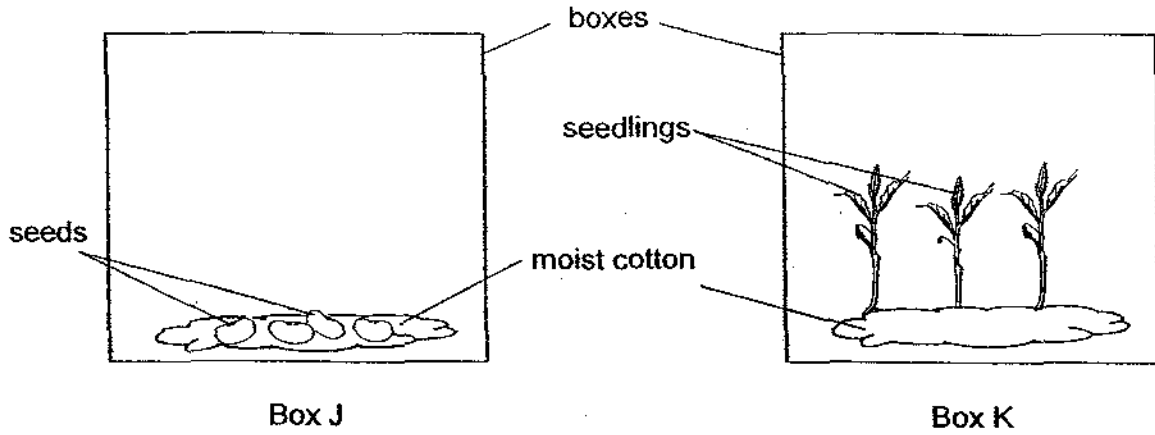

After four days, Kayden opened the boxes to check the beans and seedlings.

- (a) What would Kayden observe after the four days? Write his observations in the table below. [1]

Box	Observation
J	
K	

- (b) Explain your answer in part (a). [2]

36. Lily set up the experiment below in a dark room. She placed a sheet of paper in between the light source and the beaker of pond weeds.

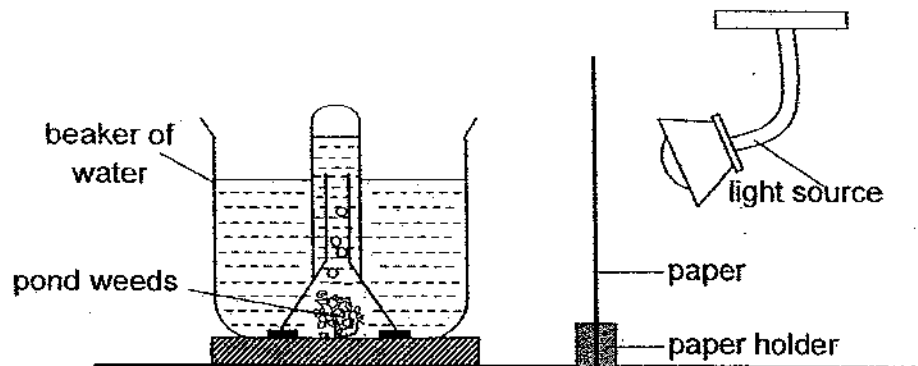

The height of the gas collected in the test tube was measured and recorded in the table below. The same set-up was used to repeat the experiment with different number of sheets of paper.

Number of sheets of paper	Height of gas collected/ mm
1	2.5
2	2
3	1.5
4	1
5	0.5

- a) How is the height of gas collected in the test tube affected by the number of sheets of paper between the light source and the pond weed? [1]

- (b) What variables should be kept the same in this experiment? [1]

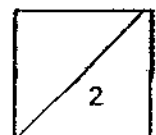

37. Sue wanted to investigate whether living things can respond to changes. She prepared the following apparatus:

- 1 retort stand
- 1 torchlight
- 1 box, half covered with a lid
- 10 similar mealworms

(a) Arrange the steps Sue must take to conduct her investigation, using all the apparatus she has prepared. [2]

Place the mealworms into the box.	
Attach the torchlight to the retort stand so that the light is shining downwards.	
Place the box under the light.	
Observe the mealworms for a few minutes and record the observations.	

(b) What is the expected result of Sue's experiment? [1]

38. Tom wanted to separate two identical glasses that were stuck to each other as shown below.

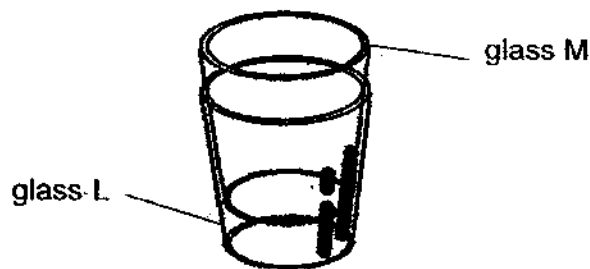

a) What can Tom do to separate the glasses? [1]

b) Explain your answer in part (a). [2]

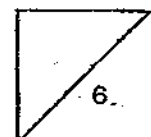

39. Study the classification table below.

Group A	Group B
balloon	iron nail
styrofoam box	spectacles
swim board	coin
wooden disposable chopsticks	eraser

a) Write a suitable heading for group A and group B. [1]

Group A _____

Group B _____

b) In which group, A or B, does a cork of a wine bottle belong to? [1]

c) What property of iron makes it suitable to be used to make a nail? [1]

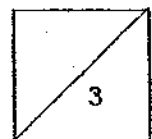

40. Derek heated identical stones in boiling water before he placed them into containers of equal sizes and thickness but made of different materials, P, Q and R.

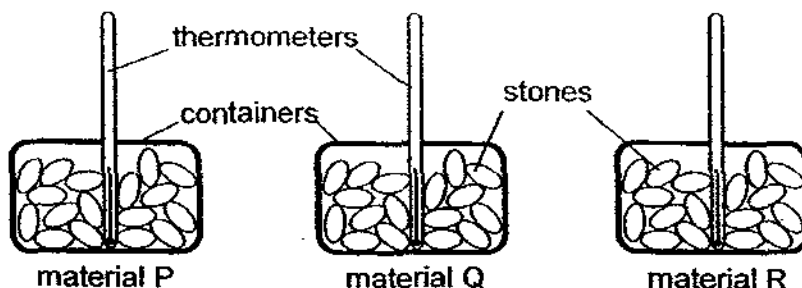

Derek recorded the temperature of the stones in each container over 20 minutes and plotted the results in the graph below. The room temperature was 27°C .

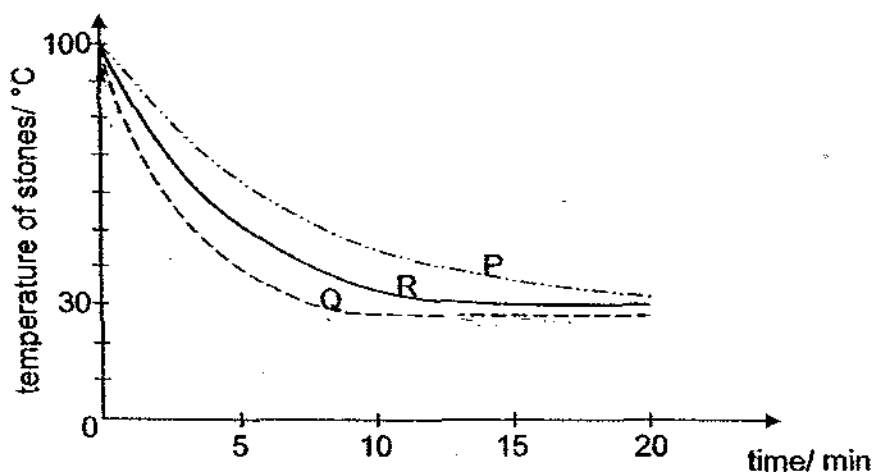

- a) Which material is the best conductor of heat? [1]

- b) Which material, P, Q or R is the best material for making a lunchbox to keep food warm? Why? [1]

- c) Derek repeated the experiment with another container made of material B. The stones in this container cooled faster than those in the container made of material Q.

In the graph above, draw a line to represent the change in temperature of the stones in the container made of material B. [1]

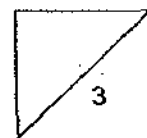

41. Tini set up the experiment shown below. She attached four different objects, J, K, L and M, one at a time, to the cardboard and fastened it with a tape.

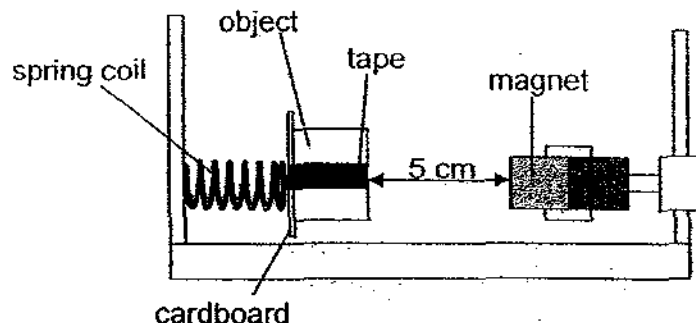

She observed the spring coil after she had placed a strong magnet 5 cm from each object and recorded her observation in the table below.

Object	Length of spring coil
J	increase
K	increase
L	decrease
M	remained the same

- a) Put a tick (✓) in the appropriate boxes below to show if each of the following statements are true, false or not possible to tell. [1]

Statement	True	False	Not possible to tell
(i) Object J is a magnet.			<input checked="" type="checkbox"/>
(ii) Object M is not a magnet.			
(iii) Object K is made of cobalt.			

- b) Which factors must Tini keep the same throughout the experiment so that her test is a fair one? Put a tick (✓) in the appropriate box(es). [1]

(i)	Type of magnet	<input type="checkbox"/>
(ii)	Material of objects J, K, L and M	<input type="checkbox"/>
(iii)	Initial distance between the strong magnet and the object	<input type="checkbox"/>

- c) Tini concluded that object L is a magnet. Is she correct? Explain your answer. [2]

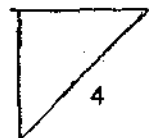

42. A torchlight was shone onto a mug from positions 1 and 2.

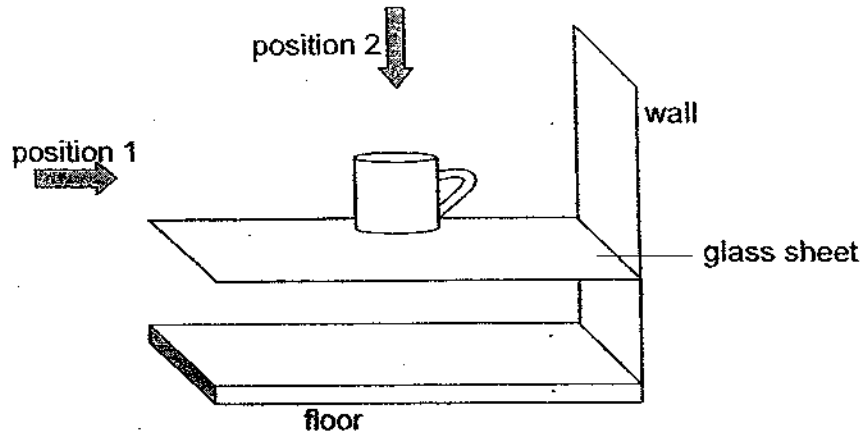

a) Draw, in the box provided, the shadow formed by the mug when the torchlight is shining from position 1 and 2. [2]

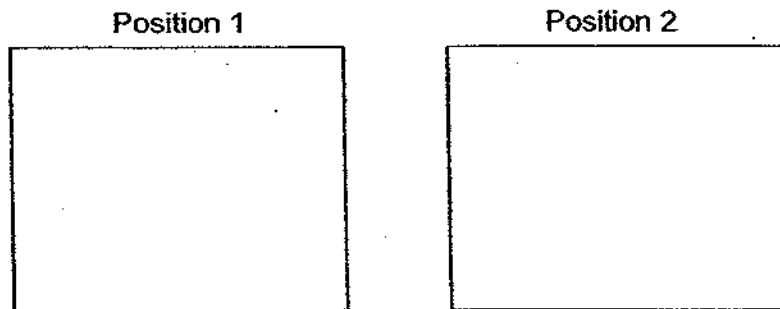

b) What property of light allows the shadows to be formed? [1]

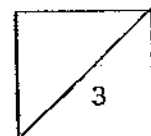

43. Four buzzers, W, X, Y and Z, were connected to an electrical circuit. When electricity passes through the buzzer, it will sound.

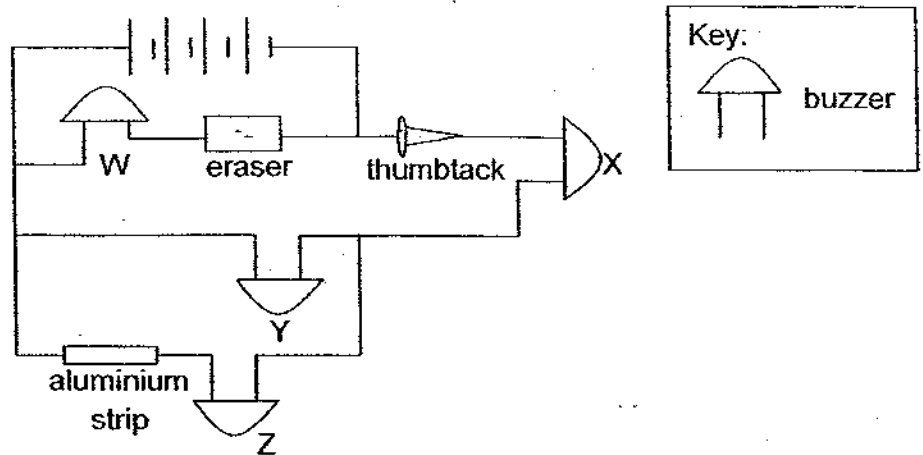

- a) Which buzzer(s) will not sound? Explain your choice of answer. [2]

- b) When the positions of the eraser and the thumbtack are exchanged, which buzzer(s) will sound? [1]

44. Danny set up a circuit card using only two pieces of wires to connect the paper clips, P, Q, R and S, on the card. He hid the wires on the back of the card and asked his friend to guess which clips were connected by the two wires.

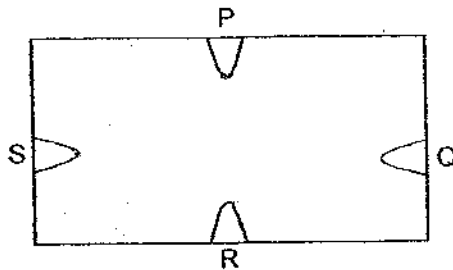

Danny's friend tested the circuit card and recorded if the bulb had lit up in the table below.

Clips tested	Results
P and Q	did not light up
P and S	light up
P and R	light up
Q and R	did not light up
Q and S	did not light up
R and S	light up

- a) According to the results obtained, draw, in the diagram above, how the two wires are connected in the circuit card. [2]
- b) In the box below, draw an electrical circuit to show the connection of one bulb, three batteries, one switch and wires so that the bulb will give out the brightest light possible. [1]

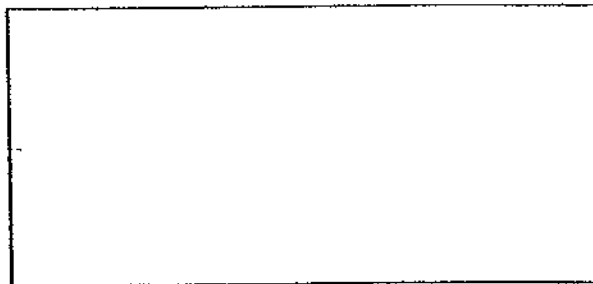

- c) What will happen to the bulb in part (b) when more and more bulbs are added into the circuit? [1]

- End of Paper -

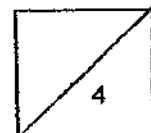

ANSWER SHEET

EXAM PAPER 2009

SCHOOL : CATHOLIC HIGH PRIMARY SCHOOL
SUBJECT : PRIMARY 5 SCIENCE

TERM : SA 1

Q1	Q2	Q3	Q4	Q5	Q6	Q7	Q8	Q9	Q10	Q11	Q12	Q13	Q14	Q15	Q16	Q17
2	4	1	2	4	4	3	4	4	1	3	2	3	4	4	4	1

Q18	Q19	Q20	Q21	Q22	Q23	Q24	Q25	Q26	Q27	Q28	Q29	Q30
3	2	3	4	2	4	2	4	1	3	4	4	2

31)Difference: The life cycle of the penguin has three stages while the life cycle of the Mealworm Beetle has four stages.

Similarity: They both lay eggs.

32)a)Cell T. It has chloroplast that contain chlorophyll which traps sunlight to make food.

b)Cell U.

33)a)E.

b)D.

34)a)Oxygen.

b)Carbon dioxide + water → oxygen + sugar

35)a)J: The seeds had germinated into a seedling.

K: The seedling had died.

b)The seeds in J had germinated into a seedling because it has warmth, water and air to germinated while the seedling in K had died because it does not have light energy for the plants to absorb for photosynthesis so the seedling died.

36)a)The more the number of sheets of paper is added, the height of gas collected decrease.

b)Type of paper, distance between the source of light and the paper.

37)a)1,2,3,4

b)The mealworms will go under the shade of the half covered box with a lid.

38)a)Immerse it into hot water.

b)Glass is a poor conductor of heat. Glass L will gain heat first and expand before glass M.

39)a)Object that float on water.

Object that sink in water.

b)Group A.

c)It is hard.

40)a)Q.

b)P. It has the minimum heat lost.

c)

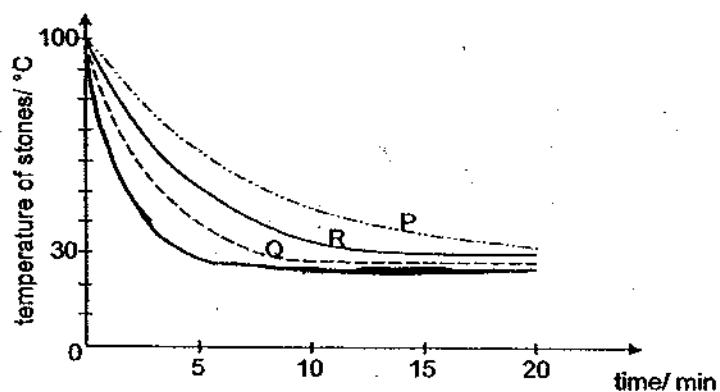

41)a)i)Not ii)T iii)Not

b)i, iii

c)Yes. The spring was compressed showing that the object repelled the magnet only magnets can reach each other.

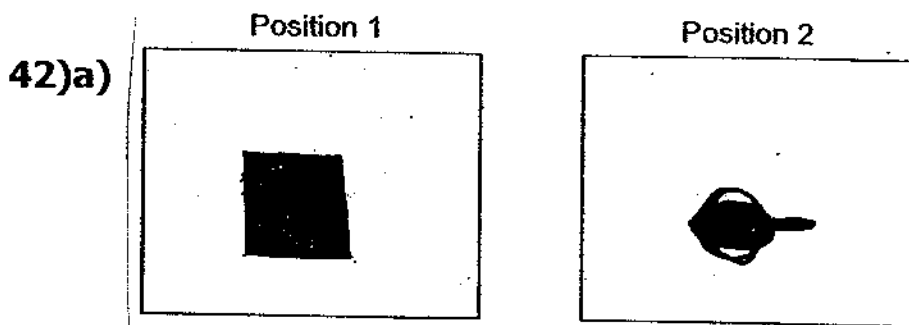

b) Light travels in a straight line.

43)a) W. Eraser is made of rubber. Rubber is not a conductor of electricity.

b) W.

44)a)

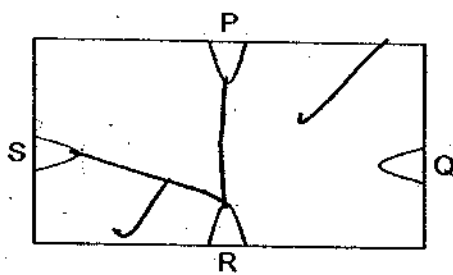

b)

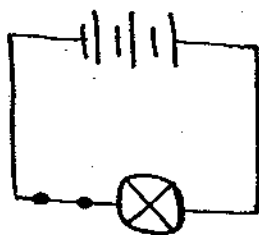

c) The bulb will become dimmer until it reaches a point when it will not light up at all.