

NANYANG PRIMARY SCHOOL

PRIMARY 5 SCIENCE

**SEMESTRAL ASSESSMENT 1
2009**

BOOKLET A

Date : 8 May 2009

Duration : 1 h 45 min

Name : _____ ()

Class: Primary 5 ()

Marks Scored:

Booklet A:		60
Booklet B :		40
Total :		100

Parent's signature:

**DO NOT OPEN THIS BOOKLET UNTIL YOU ARE TOLD TO DO SO.
FOLLOW ALL INSTRUCTIONS CAREFULLY.**



Booklet A consists of 19 printed pages including this cover page.

Section A (30 x 2 marks = 60 marks)

For each question from 1 to 40, four options are given. One of them is the correct answer. Make your choice (1, 2, 3 or 4).

Shade the correct oval (1, 2, 3 or 4) on the Optical Answer Sheet provided.

1. The following table shows how different things are classified.

Group 1		Group 2	
			
iron nail	aluminium foil	raincoat	drinking straws
			
copper wires	frying pan	wooden table	notebook

Which of the following properties can be used for the classification of the objects above ?

- A metallic or non-metallic
- B magnetic or non magnetic substances
- C conductors or non conductors of electricity

- (1) A and B only
- (2) A and C only
- (3) B and C only
- (4) A, B and C

2. The following drawing shows the floor plan of a classroom.

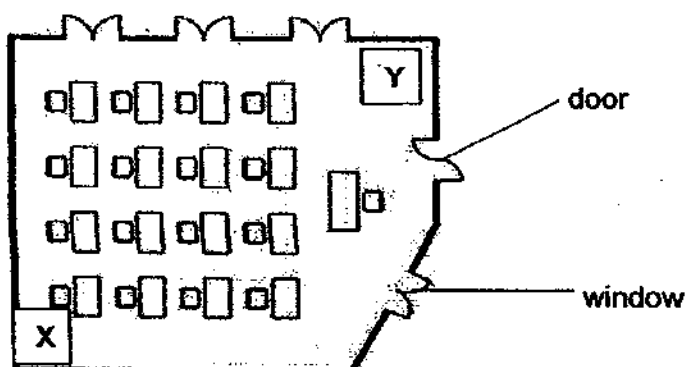

Two classmates, Wei Ling and Han Ming, conducted an experiment to show a property of gases. Wei Ling stood at X with a spray can of air freshener while Han Ming stood at Y. When Wei Ling released two puffs from the air freshener, Han Ming timed and detected the scent from the gas in 30 seconds.

Which properties of gases are demonstrated in their experiment?

- A A gas has mass.
 - B A gas takes up space.
 - C A gas can be compressed.
 - D A gas takes up the volume of its container.
- (1) A and C only (2) B and D only
(3) A, C and D only (4) A, B and D only

3. An experiment was set up by putting a glass mug in a beaker of water. The water level was marked on the beaker as well as the glass mug.

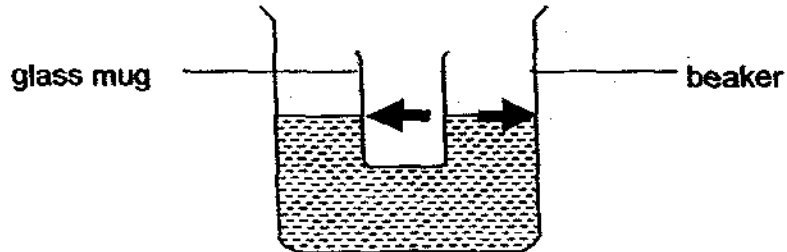

When a stone was placed in the glass mug, the mug did not sink to the bottom of the beaker. Which one of the following shows the result of the experiment ?

(1)

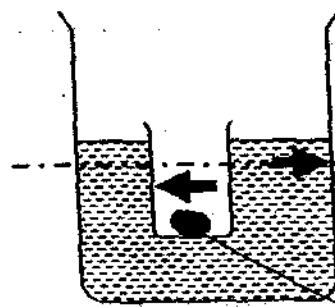

(2)

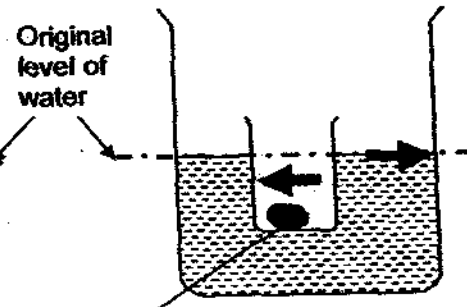

(3)

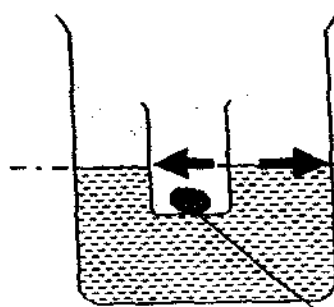

(4)

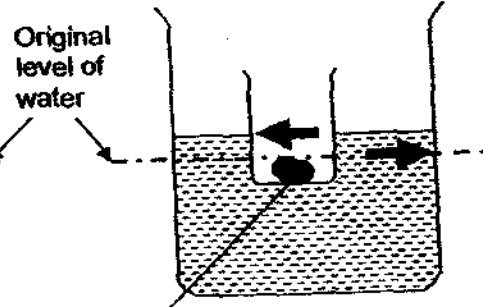

4. Study the classification table below.

Group A	Group B
jellyfish water sand	heat shadow force

In which of the groups above would you place 'wind' and 'sunlight' ?

	'wind'	'sunlight'
(1)	B	B
(2)	A	B
(3)	B	A
(4)	A	A

5. The diagram below shows the water cycle. A, B, C and D are processes occurring in the water cycle.

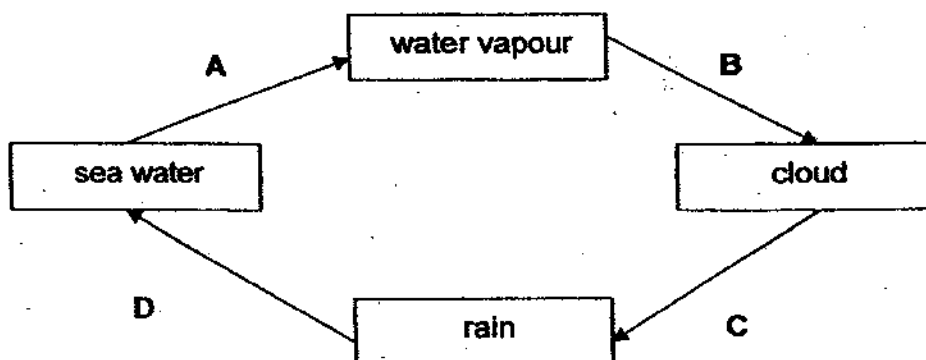

In which of the processes would a change of state of water occur?

- | | |
|---------------------|---------------------|
| (1) A and B only | (2) C and D only |
| (3) A, C and D only | (4) A, B and C only |

6. Brandon knows that salt lowers the freezing point of water. He designed the following experimental set-up and placed it in a freezer which he could control the temperature.

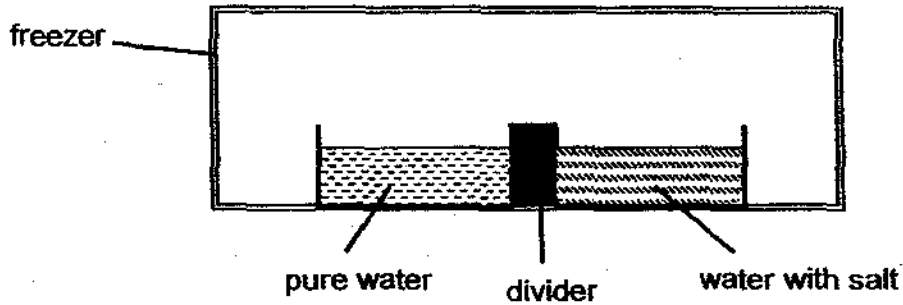

Which one of the following is observed in the set-up when the freezer is set at 0°C ?

	pure water	water with salt
(1)	solid	solid
(2)	liquid	liquid
(3)	liquid	solid
(4)	solid	liquid

7. Two substances E and F and their states at different temperatures are shown below.

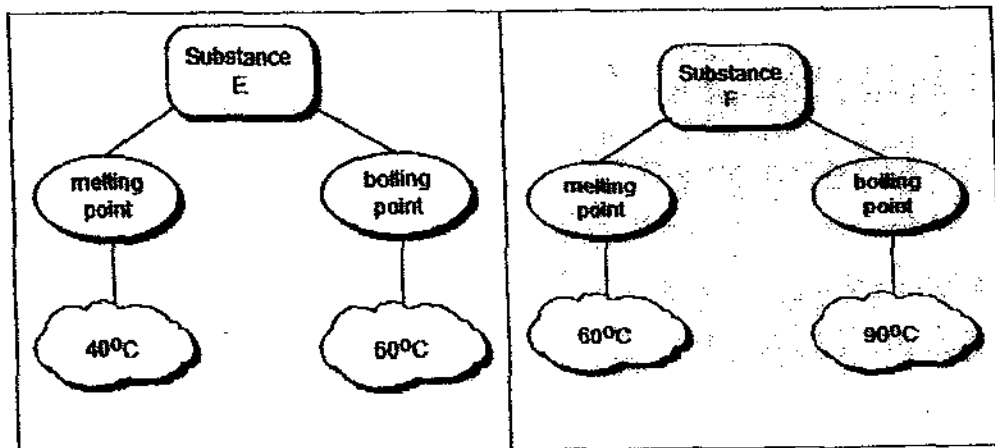

Which one of the following statements describes substances E and F correctly ?

- (1) Both substances boil at 75°C
- (2) At 60°C , both substances are gases.
- (3) At 50°C , both substances are in the same state.
- (4) Both substances are solid at room temperature.

8. Which one of the statements below is not true about evaporation and boiling ?

- (1) Both processes occur in liquids.
- (2) Both processes require heat to be gained.
- (3) Both processes occur at a fixed temperature.
- (4) Both processes require a change of state of matter

9. The picture below shows droplets of water on blades of leaves.

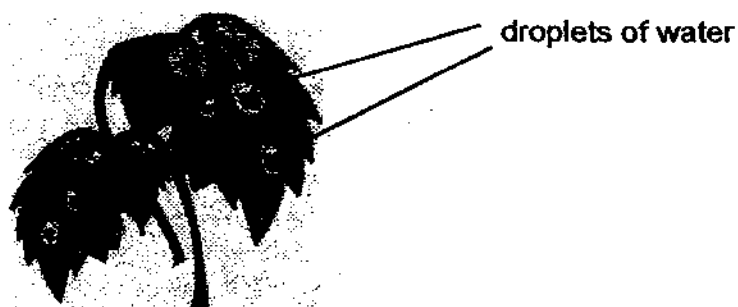

Which of the following could have caused the droplets of water to be found on the blade of leaf ?

- A The temperature of the air is cool.
- B Condensation of water vapour in the air.
- C The leaf is absorbing water vapour from the air.
- D Evaporation of water from the plant has taken place.

- (1) B only
- (2) A and B only
- (3) B and C only
- (4) B, C and D only.

10. Look at the picture below.



The plant in the picture was found growing on a rock in the ecogarden of the school. Which one of the following questions would help you to confirm that it is a non-flowering plant?

- (1) How do the flowers look like?
- (2) Do the leaves contain chlorophyll?
- (3) Are spores present under the leaves?
- (4) Does the plant have roots, stems and leaves?

11. Which one of the following statements about plants is true?

- (1) Flowering plants bear fruits.
- (2) All flowering plants are found on land.
- (3) Non-flowering plants do not make food.
- (4) Ferns and mosses have flowers once a year.

12. The table below shows a classification of animals. Which group of animals is correctly classified?

	Mammals	Insects	Fish	Birds
(1)	Shark	Moth	Eel	Eagle
(2)	Giraffe	Termite	Dolphin	Owl
(3)	Seal	Beetle	Tuna	Sparrow
(4)	Whale	Spider	Swordtail	Alligator

13. Look at the following pictures of two animals.

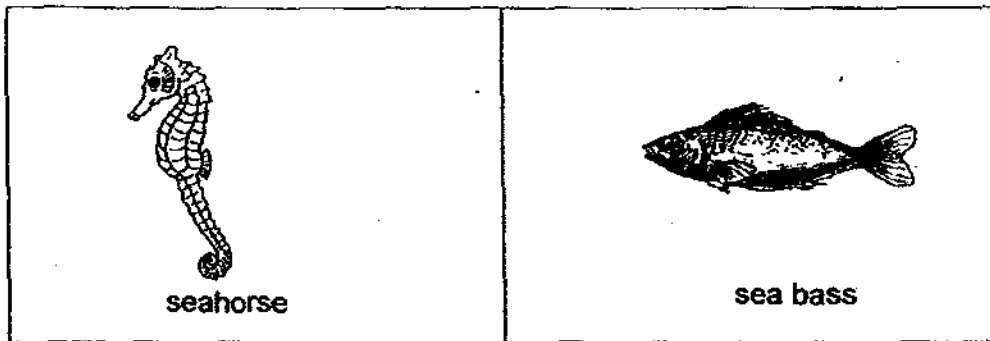

Which two statements confirm that both animals are fish?

- A Both animals have gills.
- B Both of them have tails.
- C Both animals have scales.
- D Both of them live in the sea.

- (1) A and C✓
- (3) B and D✗

- (2) B and C✗
- (4) C and D✗

14. Look at the experimental set-ups below. They are related to the body coverings of animals.

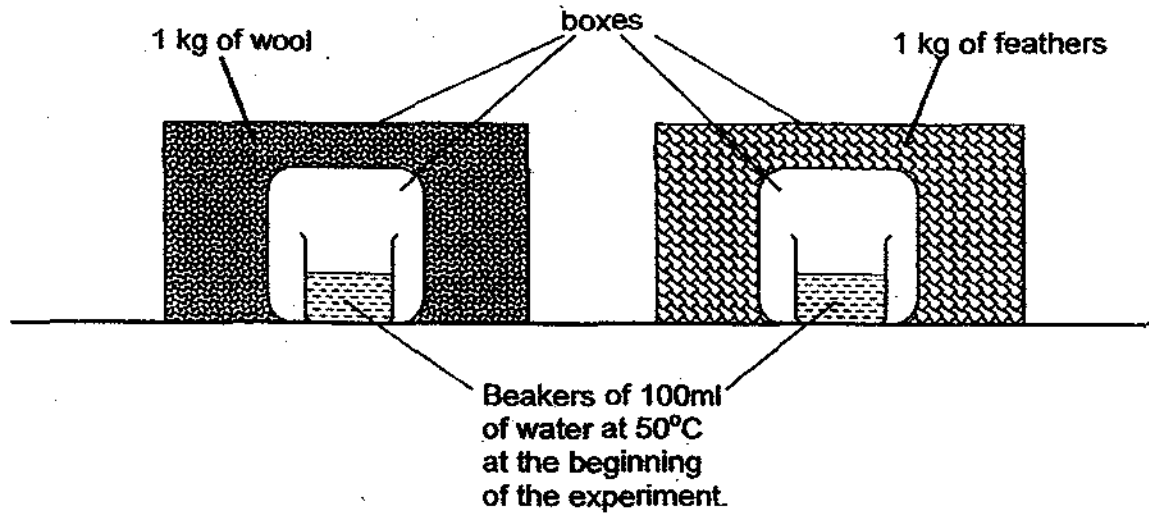

The above set-ups were left alone for 2 hours before the temperature of the water was measured.

Based on the experimental set-ups shown, what do you think is the aim of the experiment ?

- (1) To show that wool is a better body covering than feathers.
 - (2) To find out how the type of body covering affects the body temperature of an animal.
 - (3) To find out how the amount of body covering affects the body temperature of an animal.
 - (4) To show how the thickness of body covering affects the body temperature of an animal.
15. Which of the following are harmful results of oil spills in seas?
- A Aquatic animals are poisoned.
 - B Aquatic animals change their diet.
 - C Aquatic animals are unable to breathe.
 - D Aquatic animals may be covered by the oil affecting their movements.
- (1) A and D only
 - (2) B and D only
 - (3) A, B and C only
 - (4) A, C and D only

16. Which of the following are actions that help to conserve water?

- A Taking frequent baths when it is hot.
- B Installing water thimbles in shower heads.
- C Using water hoses to wash cars if possible.
- D Using the half flush button at the toilet whenever possible.

- (1) A and D only
- (2) B and D only
- (3) A, B and C only
- (4) B, C and D only

17. The diagrams below show moss and bread mould.



Moss

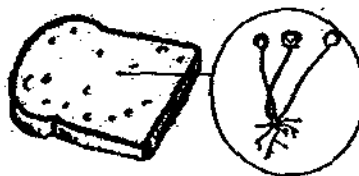

Bread mould

In what ways are moss and bread mould similar?

- A They are living organisms.
- B They make their own food.
- C They are non-flowering plants.
- D They reproduce using pollen grains.

- (1) A only
- (2) A and C only
- (3) A and D only
- (4) B and D only

18. Study the table below.

Plant	Number of spores produced each time
P	1 000
Q	12 000
R	450 000

Which one of the following is the most likely reason why Plant R produces so many spores?

- (1) Many spores are naturally useless.
- (2) To help feed animals that eat spores.
- (3) Many spores are not released from the plant.
- (4) To ensure a higher chance of survival of the species.

19. Study the diagram below and identify all the reproductive parts of the flower.

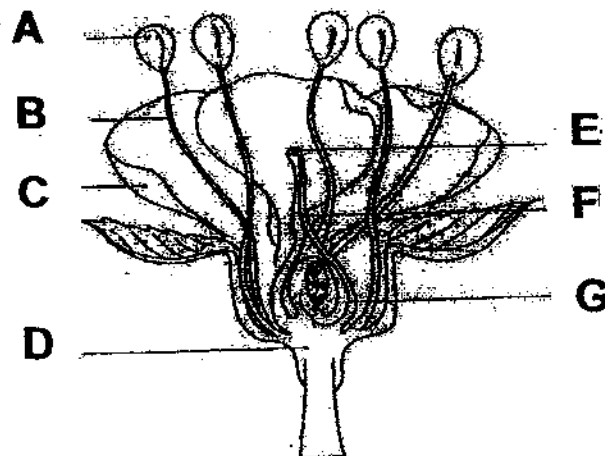

	Male Parts	Female Parts
(1)	A and B only	D, G and E only
(2)	A and B only	E, F and G only
(3)	A, B and C only	D, G and E only
(4)	A, B and C only	E, F and G only

12

20. The diagrams below show a flower containing nectar and two birds, F and G, with different types of beaks.

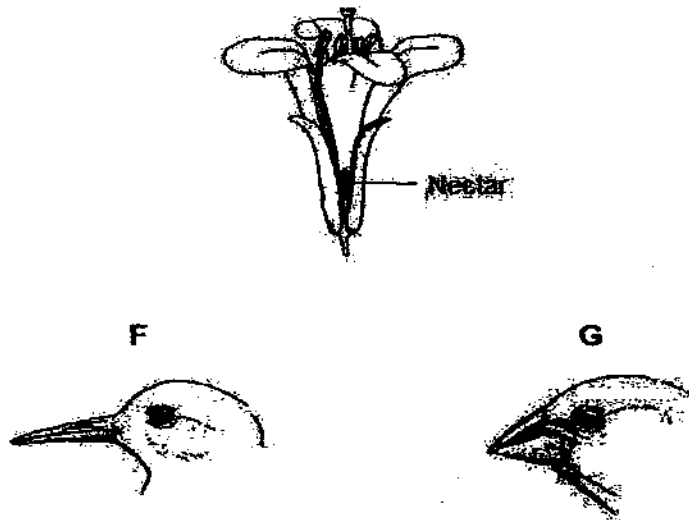

Which bird is more likely to be important to the flower and for what reason?

Bird	Reason
(1) F	Transfer nectar to another flower.
(2) F	Transfer pollen to another flower.
(3) G	Disperse its seeds after eating the flower.
(4) G	Pollinate the flower with pollen from another flower.

21. Both male and female parts can be found on the flowers of a lemon tree. David carried out an investigation on four similar lemon flowers, P, Q, R and S, to find out whether a fruit can be produced when certain parts of the flowers are removed.

	Lemon Flowers			
	P	Q	R	S
Male parts	removed			removed
Female parts		removed		
Petals			removed	removed

The table above shows the parts of flowers which have been removed. Which flower(s) is/are still able to become a fruit?

- (1) R only
- (2) P and R only
- (3) Q and S only
- (4) P, R and S only

22. The diagrams below show the fruits of three plants.

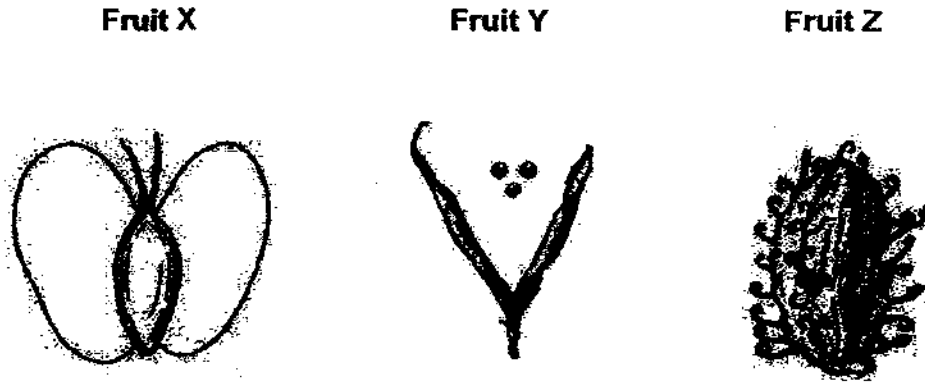

The dispersal patterns A, B and C of these three plants are shown below.

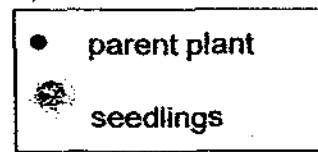
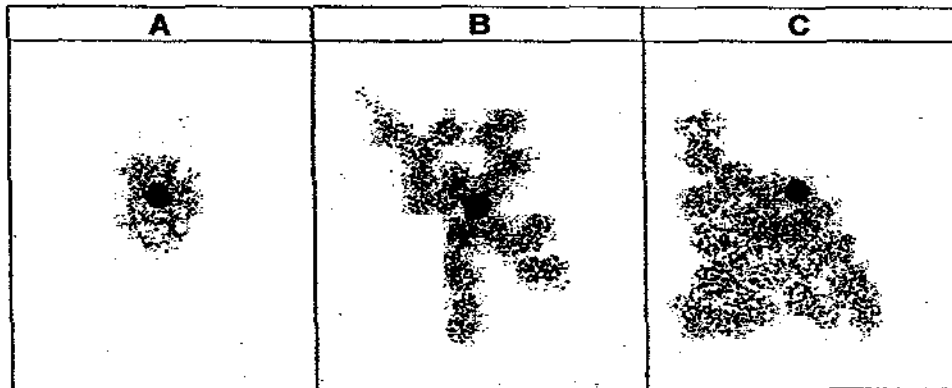

Which pattern above best matches the dispersal methods of the Fruits X, Y and Z?

	Fruit X	Fruit Y	Fruit Z
(1)	A	B	C
(2)	C	B	A
(3)	B	C	A
(4)	C	A	B

23. Use the following key to help you identify plants P, Q, R, S and T.

- (a) If the plant produces seeds, go to (b).
If the plant produces spores, call it plant P.
- (b) If the fruit is dispersed by wind, go to (c).
If the fruit is dispersed by another way, go to (d).
- (c) If the fruit has wing-like structure, call it plant Q.
If the fruit is light with feathery structure, call it plant R.
- (d) If the fruit is dispersed by water, call it plant S.
If the fruit is dispersed by splitting, call it plant T.

	P	Q	R	S	T
(1)	Fern	African tulip	Mimosa	Rubber	Shorea
(2)	Moss	Angsana	Flame of the forest	Coconut	Lalang
(3)	Fern	Shorea	Dandelion	Nipah	Balsam
(4)	Moss	Mimosa	Kapok	Rambutan	Bryophyllum

24. The diagram below shows a flower.

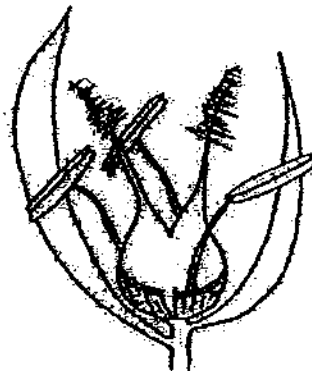

Based on the diagram only, which one of the following statements about the flower is true?

- (1) It produces a scent to attract insects.
- (2) It has feathery stigmas to catch pollen grains.
- (3) It produces nectar to attract insects for pollination.
- (4) It has hooks to cling onto the fur of passing animals.

15

25. Jason dropped three different wind-dispersed fruits E, F and shorea from a height of 4 metres and recorded the time each fruit took to land on the ground. He conducted the same experiment 3 times for each fruit.

The following table shows his results.

Fruit	Time taken (sec)		
	1 st try	2 nd try	3 rd try
E	1.1	1.0	1.1
F	4.8	4.9	5.0
Shorea	2.9	2.6	2.4

What fruit is E most likely to be?

- (1) Lalang
 - (2) Angsana
 - (3) Mimosa
 - (4) Dandelion
26. Alex conducted an experiment to determine how the duration of light exposure affects the rate of germination of seeds.
- From the options below, which two set-ups, A and B, should Alex use for his experiment?

	Set-up A			Set-up B		
	Amount of water (ml)	Duration of light exposure (hours)	Type of soil	Amount of water (ml)	Duration of light exposure (hours)	Type of soil
(1)	50	6	Sand	50	3	Sand
(2)	50	3	Garden soil	50	3	Garden soil
(3)	50	3	Garden soil	50	6	Sand
(4)	50	6	Sand	30	6	Sand

27. Which one of the following diagrams is correct about two processes in the life cycle of a plant?

(1)

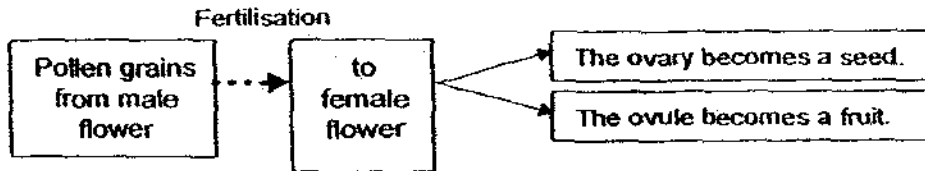

(2)

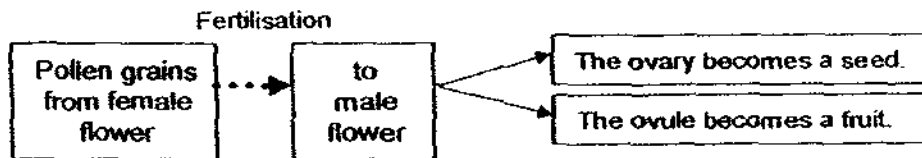

(3)

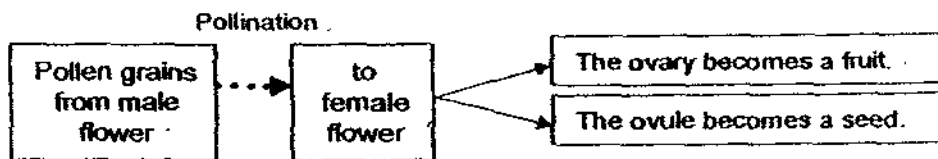

(4)

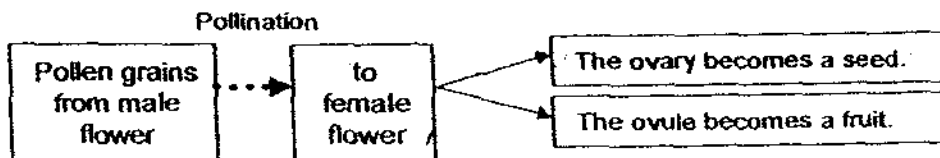

key

....→ process

→ development

28. Judy's family tree below shows the inheritance of the ability to roll the tongue.

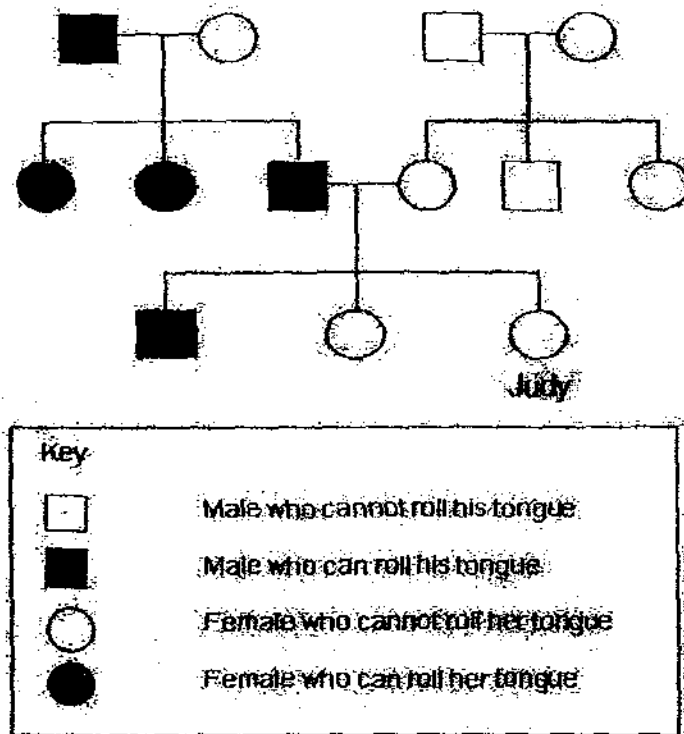

Based on Judy's family tree, which statements are correct?

- A Children cannot roll their tongues if both parents cannot.
 B Children may be able to roll their tongues if one parent can.
 C Children can roll their tongue only if their father can roll his tongue.
- (1) A and B only
 (2) A and C only
 (3) B and C only
 (4) A, B, and C

29. Study the drawings below carefully.

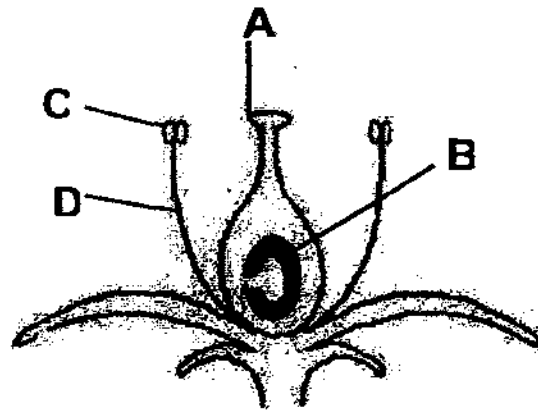

The Flower

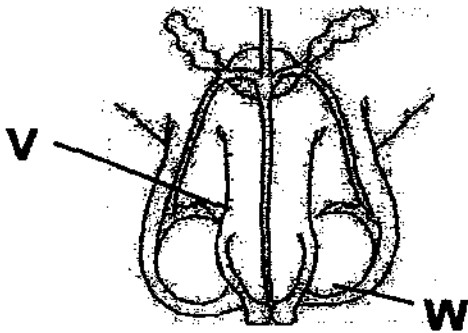

Male Reproductive System

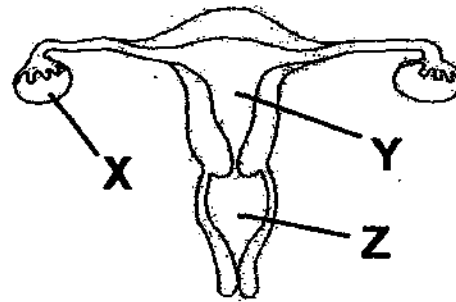

Female Reproductive System

Identify the parts in the flower and those in the human reproductive systems that produce male and female cells.

- (1) A, C, V and X
- (2) A, D, W and Y
- (3) B, C, W and X
- (4) B, D, V and X

30. The characteristics from the male parent are passed on to his young through the _____.

- (1) eggs
- (2) ovary
- (3) sperms
- (4) testes

NANYANG PRIMARY SCHOOL

PRIMARY 5 SCIENCE

**SEMESTRAL ASSESSMENT 1
2009**

BOOKLET B

Date : 8 May 2009

Duration : 1 h 45 min

Name : _____ ()

Class: Primary 5 ()

Marks Scored:

Booklet A:		60
Booklet B :		40
Total :		100

Parent's signature: _____

**DO NOT OPEN THIS BOOKLET UNTIL YOU ARE TOLD TO DO SO.
FOLLOW ALL INSTRUCTIONS CAREFULLY.**

Booklet B consists of 14 printed pages including this cover page.

Section B (40 marks)

Write your answers to questions 31 to 44 in the spaces provided.
Marks will be deducted for misspelt key words.

31. Study the following diagram.

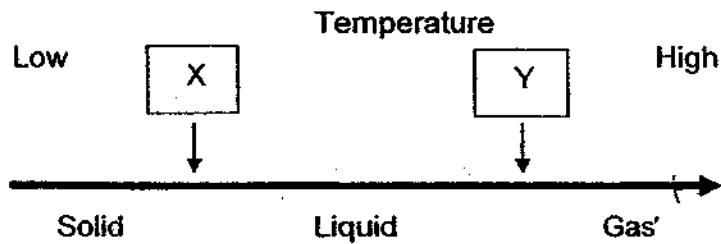

The two points, X and Y, indicates certain temperatures when changes of states of a matter take place. Write 'boiling point', 'condensation point', 'freezing point' or 'melting point' in the blanks below. (2m)

(i) X : _____

(ii) Y : _____

32. Look at the graph below.

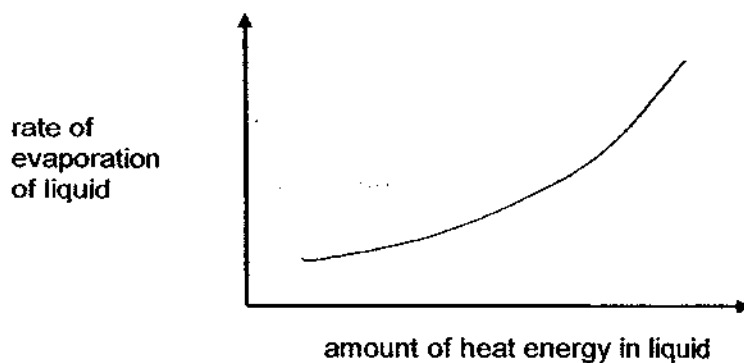

(a) Based on the information in the graph, what happens to the rate of evaporation when more heat is added to the liquid? (1m)

(b) Other than the amount of heat energy, name another factor that affects the rate of evaporation? (1m)

33. Water is a thin liquid while honey is a thick liquid. An investigation on the thickness of liquids was conducted by placing a drop of the liquid at the top of a ramp as shown in the drawing below.

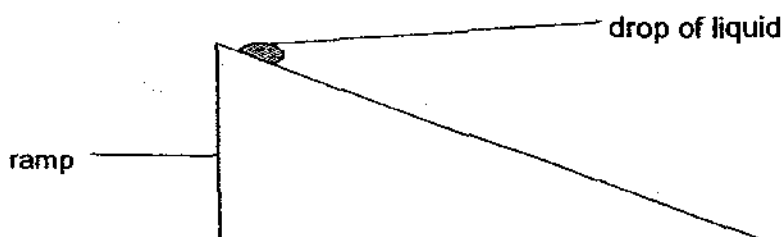

The time taken for each drop of liquid to reach the end of the ramp was noted. The results were shown in the table below.

Name of Liquid	Time taken to reach the end of the ramp
Water	27 seconds
Honey	125 seconds
Cooking oil	42 seconds
Syrup	85 seconds

(a) Based on the results in the table, suggest a reason why honey is considered the thickest liquid? (1m)

(b) If liquid M took 100 seconds to reach the end of the ramp, how would you describe its thickness when compared to the other liquids mentioned in the above table? (1m)

34. Rita prepared the following experimental set-up to determine how one factor affects the rate of evaporation.

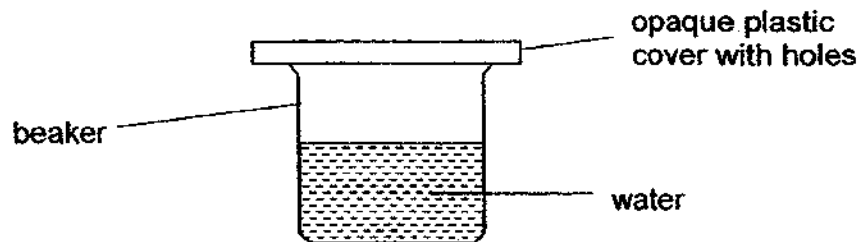

In order to carry out her experiment, Rita prepared 3 opaque plastic covers with different number of holes as shown below. Each cover was placed over its own beaker of water.

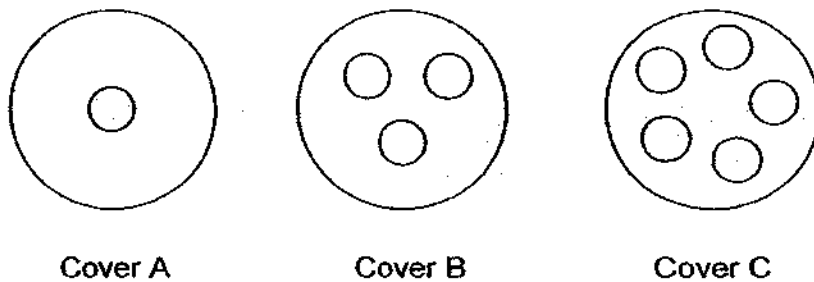

- (a) Which factor of evaporation is tested using the above set-ups? (1m)

- (b) Name a variable that must be controlled in the experiment? (1m)

- (c) What is the relationship between the number of holes in the cover and the rate of evaporation? (1m)

- (d) What needs to be measured to determine the rate of evaporation?(1m)

35. The following experiment was set up in the science room.

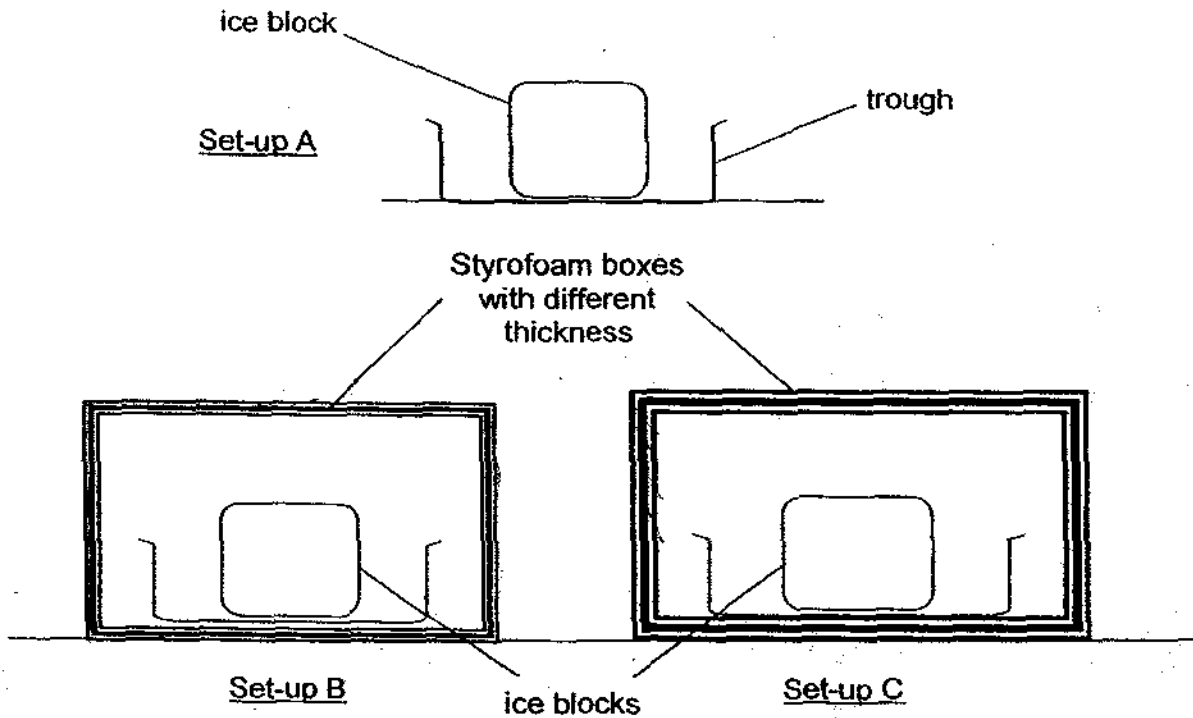

(a) What change of state occurs in the ice blocks after 1 hour? (1m)

(b) Write down a hypothesis for the experiment. (1m)

(c) Predict the difference in the experimental results if set-up B was left in the sun for 1 hour at the start of the experiment instead. (1m)

36. Study the flowchart below.

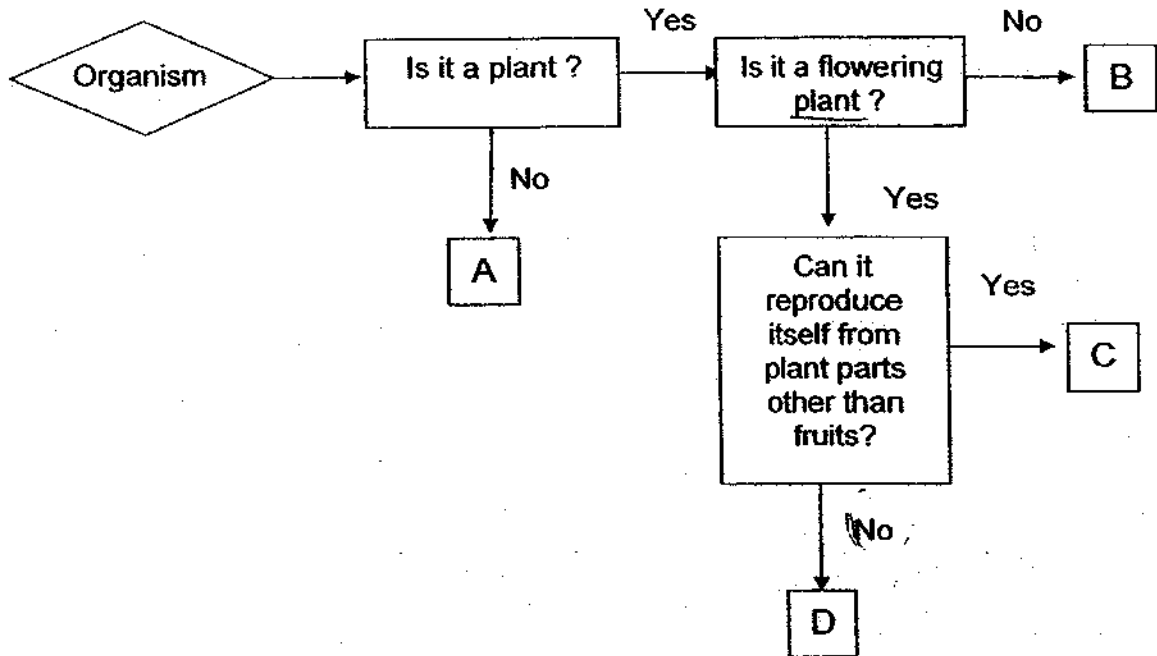

(a) Based on the information given in the flowchart, which letter A, B, C or D represents bacteria? (1m)

(b) Based on the information given in the flowchart, how would you describe organism D? (2m)

37. The following pictures show animals that are commonly found together.



mynah



bee



squirrel

(a) In which natural habitat are you most likely to see all three animals living together? (1m)

(b) The above animals are to be classified according to their body covering. Using the classification table given below, write an appropriate heading in boxes A and B and then classify the animals given by writing 'mynah', 'bee' and 'squirrel' in the appropriate boxes (C and D).

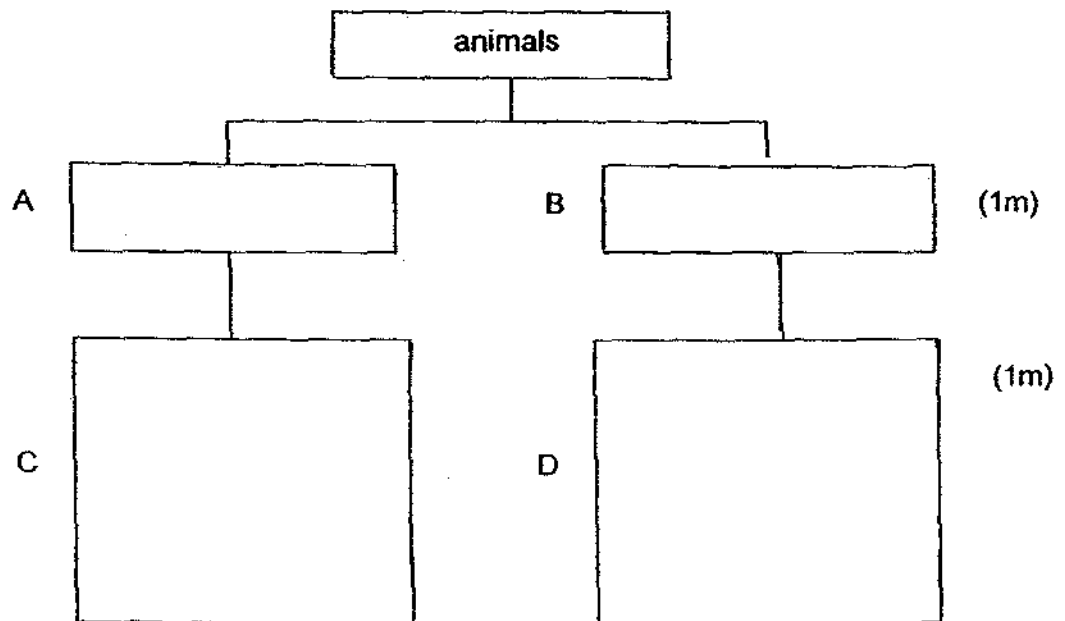

(c) Other than the number of legs, name one characteristic of the animal group which the bee belongs. (1m)

38. The picture below shows some activities along the river.

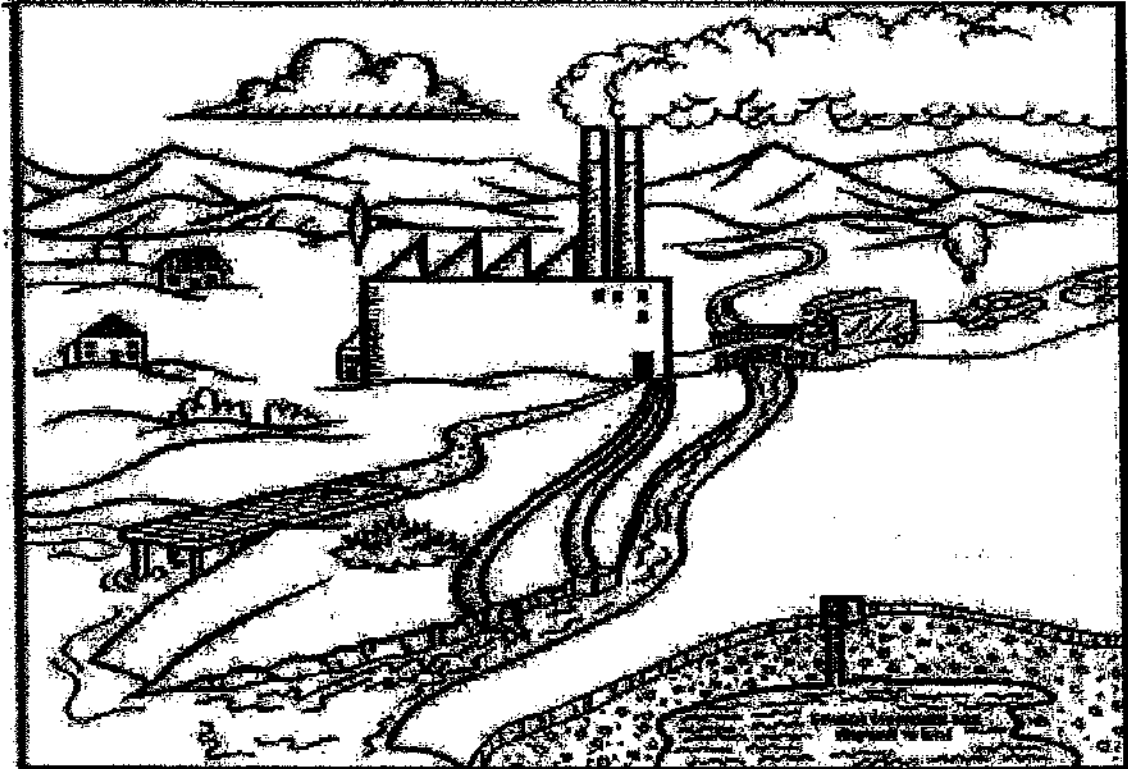

(a) Identify one source of water pollution shown in the picture. (1m)

(b) Based on your answer in (a), suggest a method to control the above water pollution. (1m)

39. The diagram shows the life cycle of a cockroach.

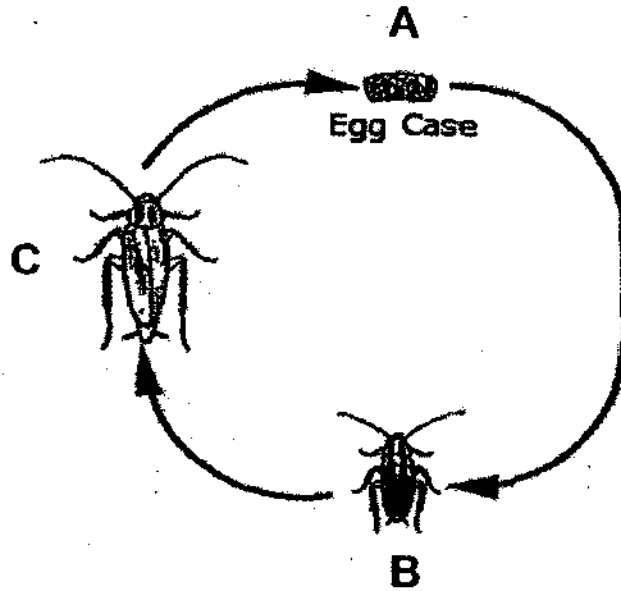

(a) At which stage A, B or C can the cockroach reproduce? (1m)

(b) Why does the female cockroach need to lay many eggs? (1m)

(c) Some mammals only produce a few young. State one way in which these mammals ensure the survival of their young. (1m)

40. Jane had a plant G in her garden. After some time, she noticed some young plants of G growing in the cracks of a wall.

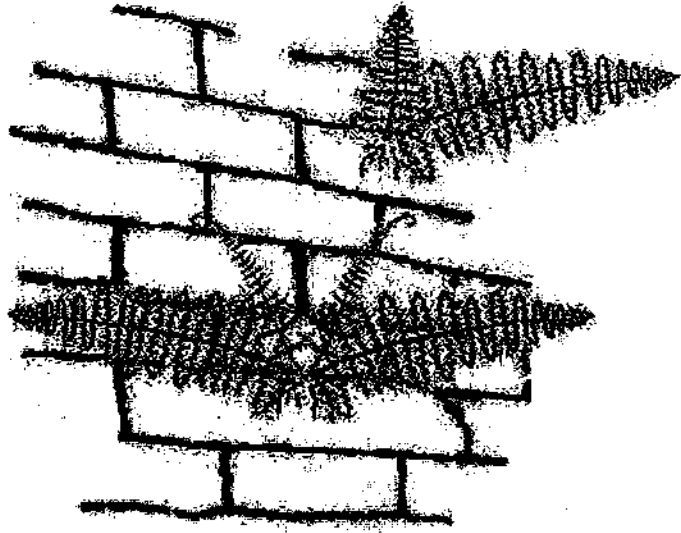

(a) Identify the plant shown above.

(1m)

(b) Suggest how the young plant of G grow on the wall.

(1m)

41. The diagram below shows the cross-section of a flower.

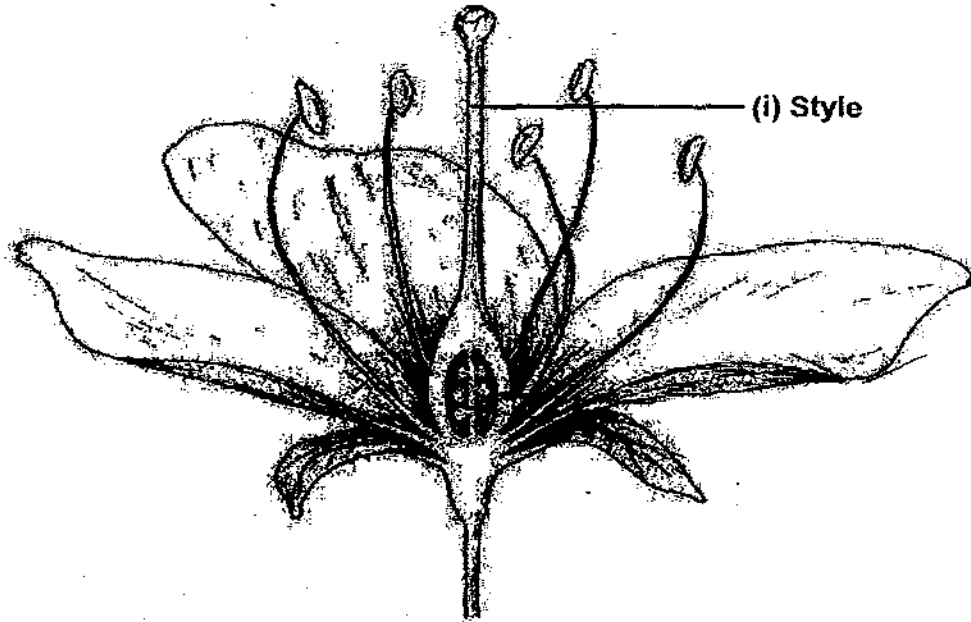

(a) On the diagram above, label and name the parts which:

- (i) allows the growth of pollen tube downwards
[Part (i) has been done for you, as an example.]
- (ii) attracts insects (**Do not** label and name the nectary)
- (iii) grows into a fruit after fertilisation
- (iv) forms seeds after fertilisation

(3m)

(b) Although Siti cuts off the stigma, the flower still develops into a fruit. Explain.

(1m)

42. The diagram below shows a pineapple plant.

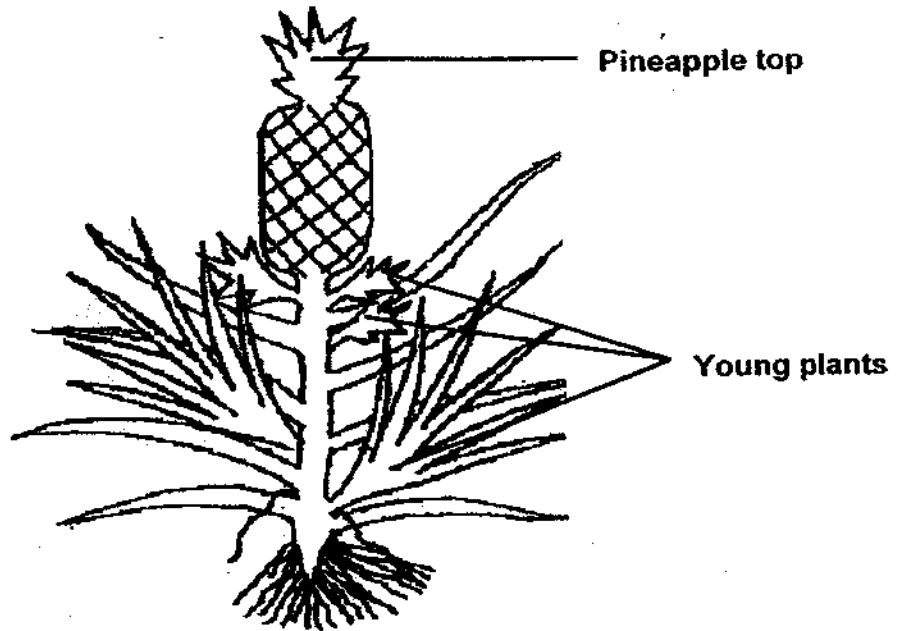

(a) A Pineapple top is planted in the soil. It grows roots and develops into a plant.
What is this method of reproduction? (1m)

(b) List a disadvantage of such a method of reproduction? (1m)

43. Elly planted three seeds in a plastic container and watered them every day. She observed the growth and development of the roots and shoots. She measured and recorded the lengths of roots and shoots in the table below.

Day	Part X (mm)			Part Y (mm)		
	Seed 1	Seed 2	Seed 3	Seed 1	Seed 2	Seed 3
1	0	0	0	0	0	0
2	0	0	0	0	0	0
3	1	2	2	0	0	0
4	3	4	3	0	0	0
5	6	7	7	2	4	3
6	10	9	9	5	6	5
7	11	11	12	9	8	9

- (a) Which part, X or Y, is the root? Explain your answer. (1m)

- (b) Elly noticed that the seedlings did not have any green leaves. Where did they get their nutrients for growth? (1m)

- (c) State the conditions for the germination of seeds. (1m)

44. Study figures A, B and C below.

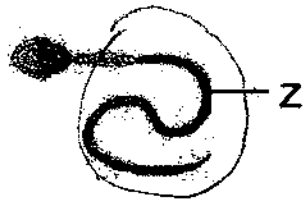

Figure A

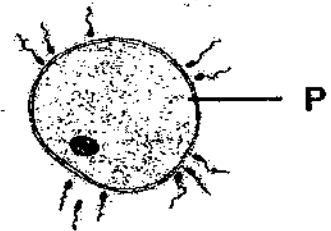

Figure B

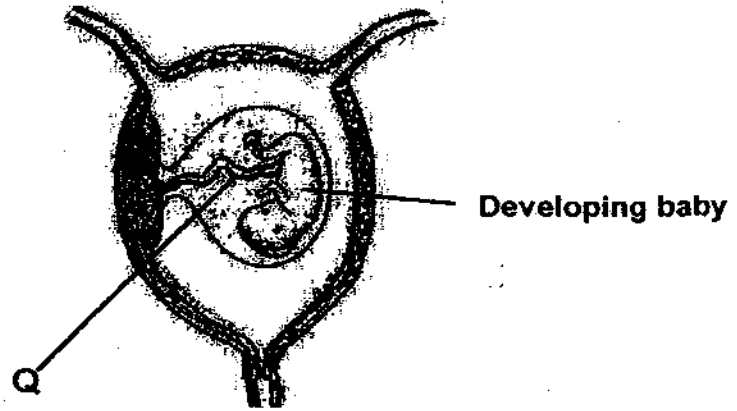

Figure C

(a) State the function of structure Z. (1m)

(b) (i) Name and explain the process occurring in Figure B. (1m)

(ii) Name the organ that produces cell P. (½m)

(c) (i) Name structure Q. (½m)

(ii) Why does the developing baby need the structure? (1m)
(½m)

-----END OF PAPER-----

Setters: Mr Ting Huat Seng
Mdm Choo Lay Kheng

ANSWER SHEET

EXAM PAPER 2009

**SCHOOL : NANYANG PRIMARY
SUBJECT : PRIMARY 5 SCINECE**

TERM : SA1

Q1	Q2	Q3	Q4	Q5	Q6	Q7	Q8	Q9	Q10	Q11	Q12	Q13	Q14	Q15	Q16	Q17
2	2	1	2	1	4	4	3	2	3	1	3	1	2	4	2	1

Q18	Q19	Q20	Q21	Q22	Q23	Q24	Q25	Q26	Q27	Q28	Q29	Q30
4	2	2	4	4	3	2	2	1	3	1	3	3

31)a)i)melting point ii)boiling point

**32)a)The rate of evaporation goes higher.
b)Presence of wind, humidity level.**

**33)a)Honey took the longest time reach the end of the ramp.
b)Liquid M is thicker than water, cooking oil and syrup but it is thinner than honey.**

**34)a)Area of exposed surface of water.
b)The amount of water must be the same in all the beaker.
c)The greater the number of holes in the cover, the higher the rate of evaporation.
d)The amount of water left in the beaker after a certain amount of time.**

**35)a)Solid to liquid.
b)The thicker the Styrofoam box, the slower melting will take place.
c)The ice block melts faster.**

**36)a)A
b)D is a flowering plant which cannot reproduce itself from plant parts other than fruits.**

**37)a)In the forest.
b)A: Fur B: Feathers C: Squirrel D: Mynah, squirrel
c)They have exoskeleton.**

38)a)Contaminated waste from the factory.

b)They should relocate the factory far away from the river.

39)a)C.

b)It is to ensure a continuity of their own kind.

c)They protect their young.

40)a)Fern.

b)The wind carried the spores of plant G to the cracks of a wall, where the spores germinated.

41)a)

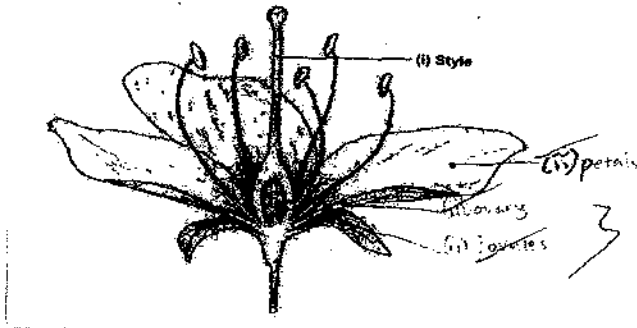

b)Fertilisation has already taken place.

42)a)Suckers.

b)The new plant only obtains good characteristics from one parent whereas plants which reproduce by sexual reproduction obtain good characteristics from two parents.

43)a)Part X. When the seed germinates, the roots would come out first.

b)They obtained their nutrients from the seed leaves.

c)Warmth, oxygen and water.

44)a)To allow Figure A to move freely.

b)i)Fertilisation A sperm fuses with the egg and fertilizes it.

ii)Ovary.

c)i)Umbilical cord.

ii)For the mother to give food nutrients and oxygen to the baby.