



Anglo-Chinese School (Primary)

END-OF-YEAR EXAMINATION 2009  
SCIENCE  
BOOKLET A  
PRIMARY FIVE

Name: \_\_\_\_\_ (     )     Class: Primary 5 \_\_\_\_\_

Date: 2 November 2009

Duration of paper: 1h 45min

\_\_\_\_\_  
Parent's/Guardian's signature

**INSTRUCTIONS TO CANDIDATES**

1. This question paper consists of 21 printed pages.
2. Do not turn this page until you are told to do so.
3. Follow all instructions carefully.
4. Shade your answer on the Optical Answer Sheet (OAS) provided.





5 The diagram below represents the water cycle.

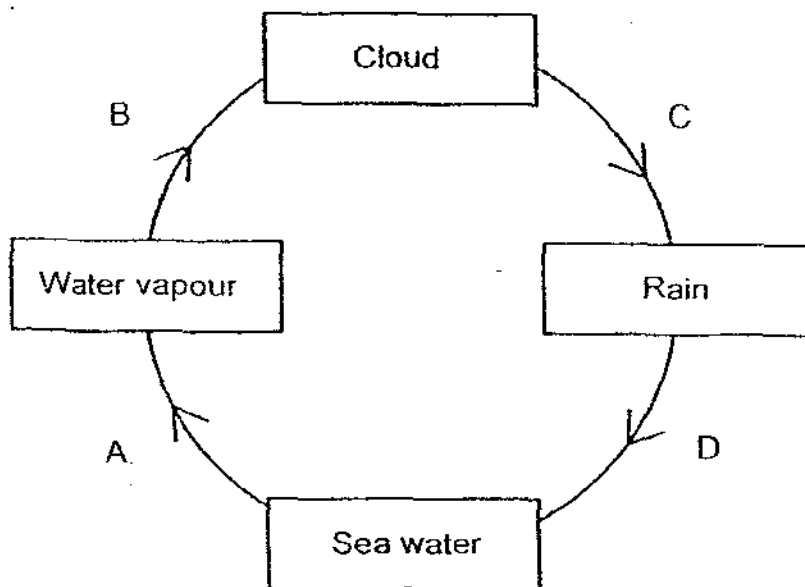

The arrows, A, B, C and D show processes in the water cycle. Which one of the following is correct?

	Heat Lost	Heat Gained
(1)	A	B
(2)	B	A
(3)	C	B
(4)	D	C

6 Study the set-ups P and Q below.

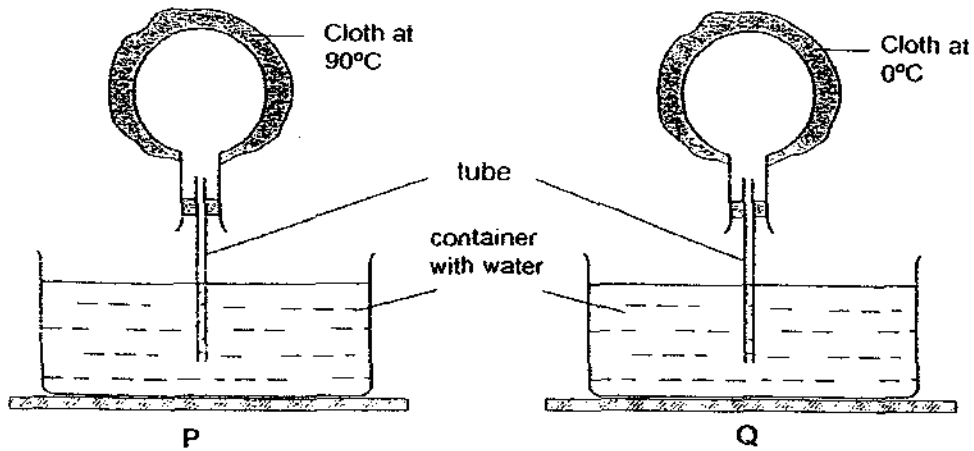

Which one of the following could be observed three minutes after the cloth were placed on the flask in set-ups P and Q?

	Observation for P	Observation for Q
(1)	Water rises up the tube	Bubbles appear from the tube
(2)	Bubbles appear from the tube	Water rises up the tube
(3)	Water rises up the tube	Water rises up the tube
(4)	Bubbles appear from the tube	Bubbles appear from the tube

7 A balsam plant was placed in a beaker of coloured water and was left overnight. The diagram below shows the cross-section of the stem of the plant after it was cut the next day.

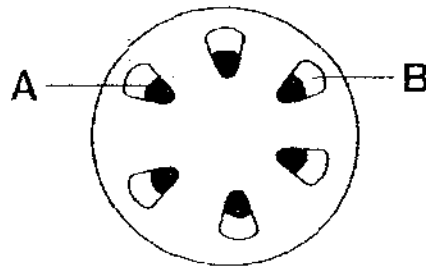

Identify and name the part of the stem that would be stained the most.

	Part stained the most	Name of the part
(1)	A	phloem
(2)	B	xylem
(3)	A	xylem
(4)	B	phloem

- 8 The graph below shows the expected change in the temperature of a beaker of ice over a period of time as it was heated over a flame.

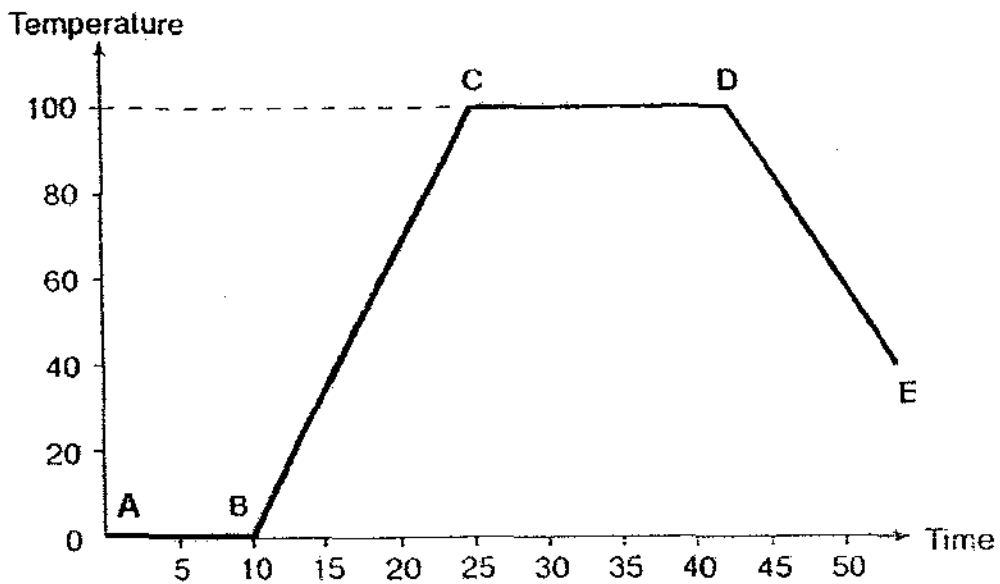

Which one of the following shows the correct description for the processes that took place at AB and CD?

	AB	CD
(1)	melting	boiling
(2)	boiling	melting
(3)	freezing	melting
(4)	freezing	boiling

- 9 A thermostat is a device used in a refrigerator for controlling the temperature of the refrigerator so that its temperature is maintained near a desired level. This thermostat switches on the refrigerator's cooling system once the temperature rises above 4°C and switches it off once the temperature falls below 2°C.

Which one of the graphs below shows how the temperature inside the refrigerator changes over time?

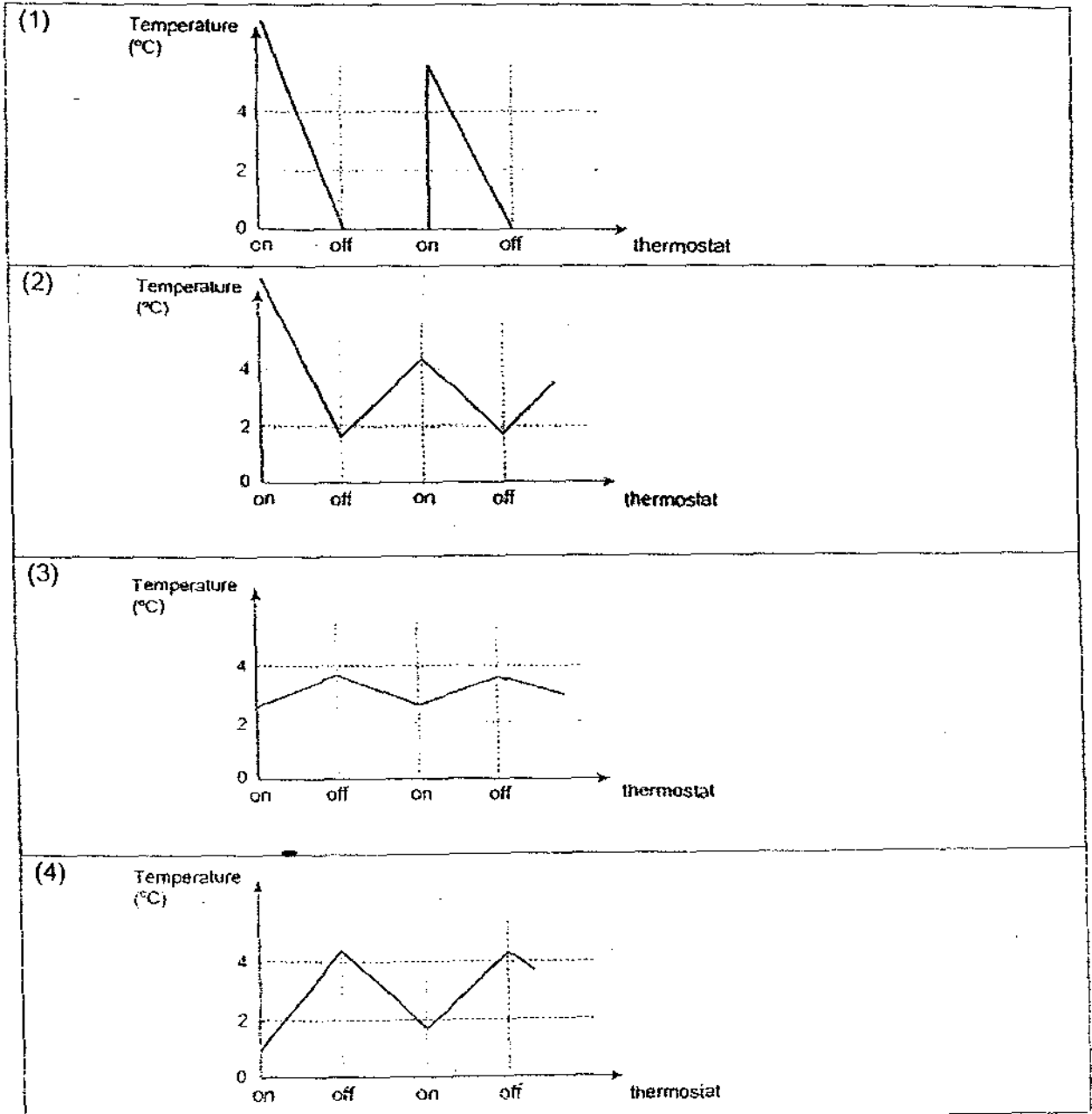

10 The diagram below shows the cell of a plant.

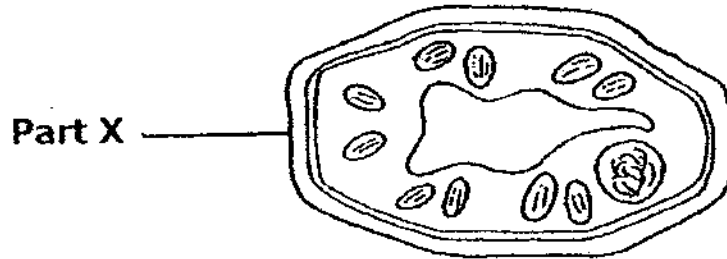

What is the main function of part X of the cell?

- (1) It controls activities in the cell.
- (2) It gives the cell a green colour.
- (3) It gives the cell its regular shape.
- (4) It controls the movement of particles in and out of the cell.

11 Which one of the following statements about heartbeat is correct?

- (1) Heartbeat occurs only in humans.
- (2) We can measure our heartbeat rate by taking our pulse.
- (3) The heartbeat rate decreases when we are exercising.
- (4) The heartbeat stops temporarily when we are sleeping.

12 Which one of the following correctly indicates the states of water in the different stages of the water cycle?

	Water vapour	Clouds	Rain
(1)	liquid	gas	liquid
(2)	gas	gas	liquid
(3)	liquid	liquid	solid
(4)	gas	liquid	liquid

- 13 A coin was placed on a piece of paper and was held over the flame of a candle for 2 minutes. When the paper was removed from the flame, the paper had a scorched surface as shown.

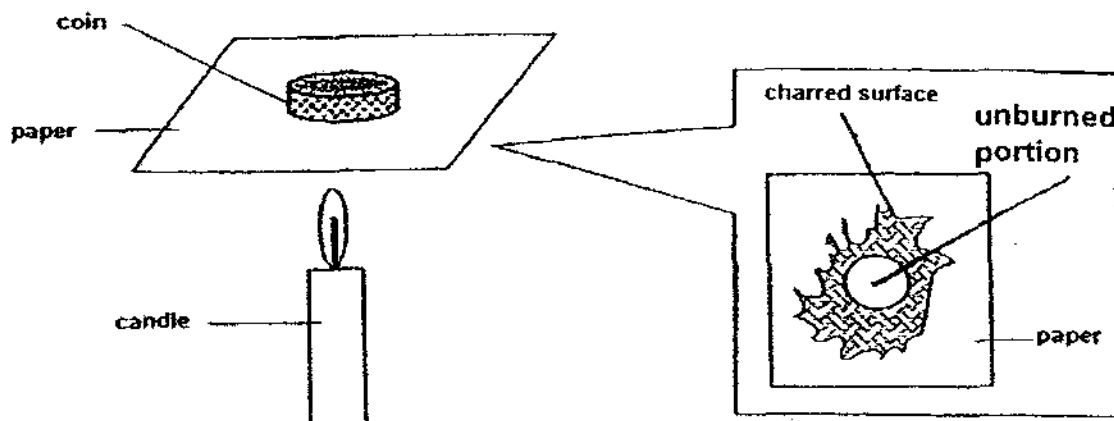

Which one of the following statements is the most likely explanation for the unburned portion of the paper as seen in the above observation?

- (1) The surface under the coin was too thick to burn.
- (2) The coin conducts heat to the paper at the unburned portion.
- (3) The candle flame did not produce enough heat for the paper to burn.
- (4) The coin conducts heat away from the paper at the unburned portion.

- 14 The amount of pollutants in a river for the past 5 years was represented by the graph shown below.

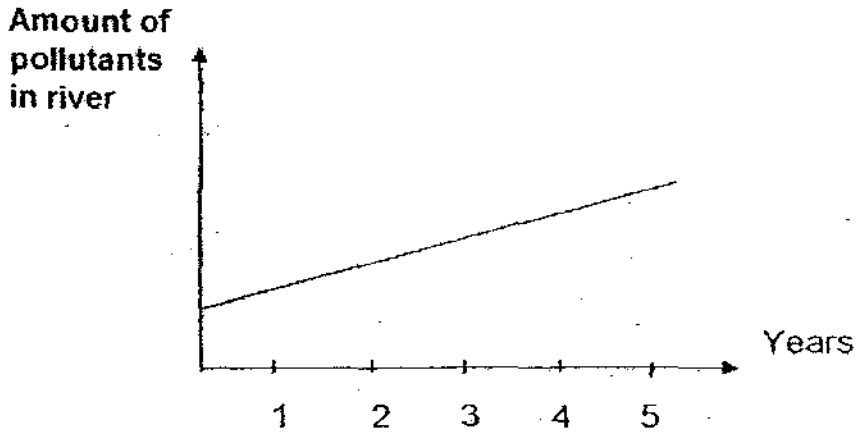

Some pollution control measures were then introduced to help curb this problem. The change in the following 2 years is shown in the graph below.

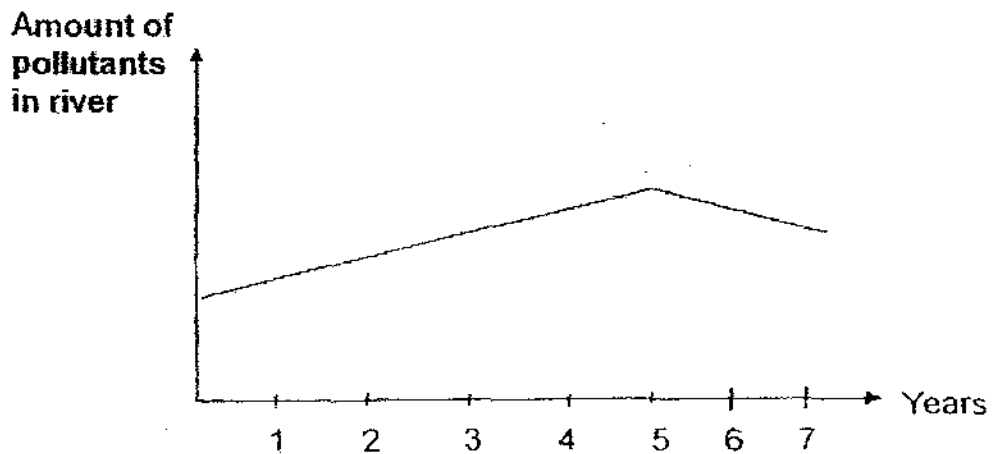

Which one of the following are you most sure could be the measure that has been implemented?

- (1) New factories were constructed close to the river.
- (2) Nearby factories were relocated away from the river.
- (3) Nearby factories were ordered to reduce the amount of noise produced.
- (4) The residents living nearby were encouraged to buy products that are environmentally-friendly.

- 15 Linda wanted to use a light microscope as shown in the diagram below to observe the parts of some plant cells.

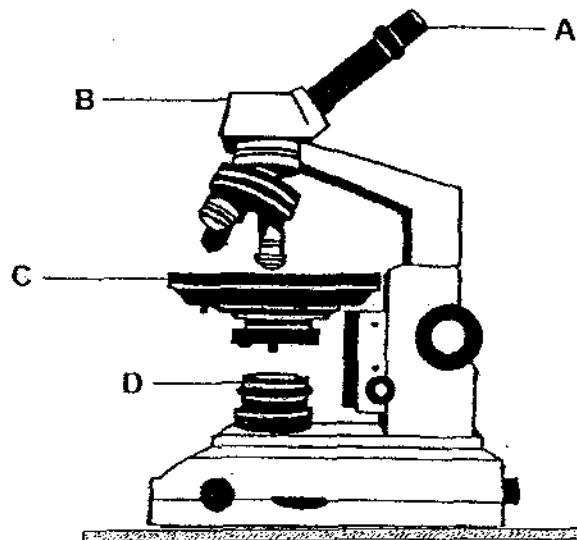

At which part of the microscope should she place the prepared slide of the plant cells?

- (1) A
- (2) B
- (3) C
- (4) D

- 16 The diagram below shows the changes in the amount of air in a 10 ml syringe when a plunger is pushed from point A to B to C.

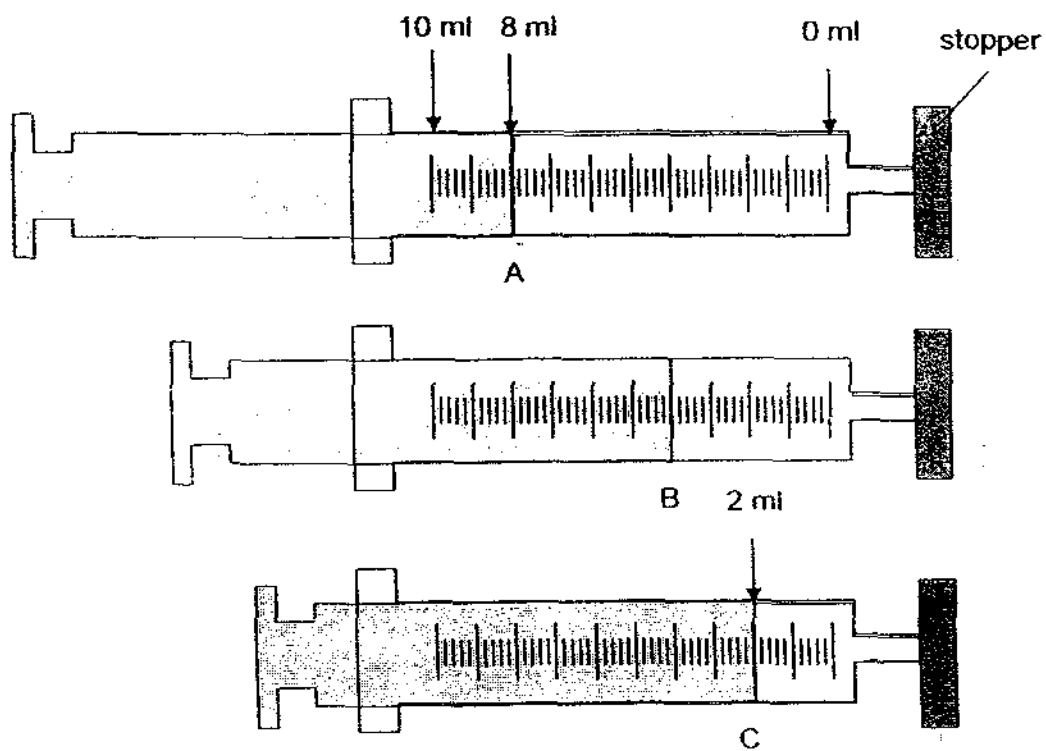

How much of the air was compressed from point A to point C?

- (1) 2 ml
- (2) 6 ml
- (3) 8 ml
- (4) 10 ml

- 17 Henry has 4 different metal blocks A, B, C and D. The table below shows the mass and volume of each block.

Block	A	B	C	D
Mass (g)	300	230	70	150
Volume (ml)	40	20	25	75

Henry lowered block A gently into the watering can below and observed if the water in the watering can overflow. He repeated this procedure with blocks B, C and D.

watering can

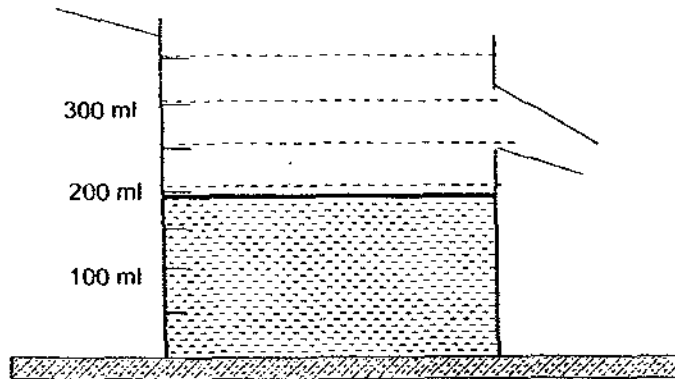

Which one of the blocks when lowered in the water will most probably cause the water in the watering can to overflow?

- (1) A
- (2) B
- (3) C
- (4) D

- 18 The table below shows the mass and boiling points of 4 liquids W, X, Y and Z.

Liquid	W	X	Y	Z
Mass (kg)	0.98	1.20	1.00	1.18
Boiling point (°C)	37	250	100	80

Based on the information in the table, which one of the following statements below is true?

- (1) W is a liquid at 40°C.
  - (2) X has the greatest mass.
  - (3) Z has a higher boiling point than Y.
  - (4) Y weighs more than 1 kg at boiling point.
- 19 David wanted to find out how the amount of wind would affect the rate of evaporation of water. David, together with his two friends, carried out an experiment at three different locations at the same time. The results are as shown below:

Item	Place where item was hung	Time taken for item to dry (hours)
wet towel	outdoor playground	2
wet table cloth	bedroom	5
wet blanket	roof top	1.5

David's teacher said that his experiment was not fair.  
How could he improve on the experiment to make it a fair one?

David could \_\_\_\_\_.

- (1) start the experiment at different times.
- (2) conduct the experiment on different days.
- (3) hang the different items at one place only.
- (4) place the same kind of item at each location.

- 20 Samuel put 4 similar empty glass beakers A, B, C and D at 4 different locations in a refrigerator. After a certain time, he took the beakers out of the refrigerator, one at a time. He shone light through it immediately and observed the shadow cast on the screen as shown in the diagram below.

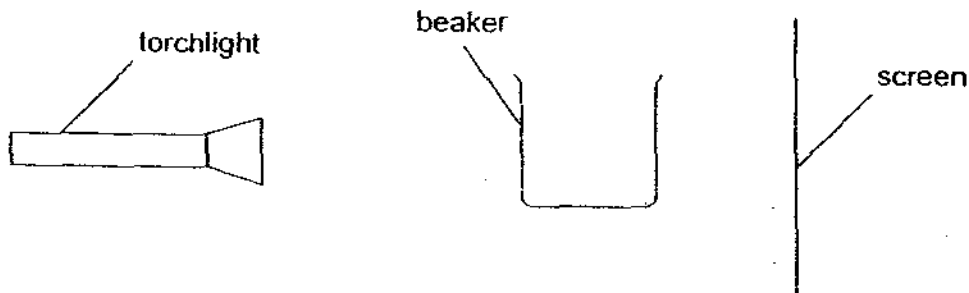

The table below was a description of the shadow cast by each beaker.

Beaker	A	B	C	D
Description of shadow	Light	Darkest	Grey	Very light

- Which beaker was the coolest at the time it was taken out of the fridge?
- (1) A
  - (2) B
  - (3) C
  - (4) D
- 21 Which one of the following characteristics cannot be passed on from one generation to another?
- (1) Skin colour
  - (2) Length of hair
  - (3) Thickness of lips
  - (4) Type of ear lobes

- 22 Which one of the following plant parts does not match its function?

	Plant part	Function
(1)	Anther	Supports the filament
(2)	Ovary	Contains the ovules
(3)	Petal	Attracts insects to the flowers
(4)	Stigma	Pollen grains are transferred to this part of the flower

23 The table below shows the various conditions of 4 set-ups.

Set-up	Number of seeds	Amount of soil (ml)	Amount of water given daily (ml)	Distance between seeds (cm)
A	0	500	10	-
B	2	500	10	8
C	2	500	10	2
D	20	500	10	1

If James wanted to find out if overcrowding affects the growth of plants, which 2 of the above set-ups can he use to draw his conclusion?

- (1) A and D
- (2) A and B
- (3) B and D
- (4) C and A

24 Which one of the bulbs below will light up?

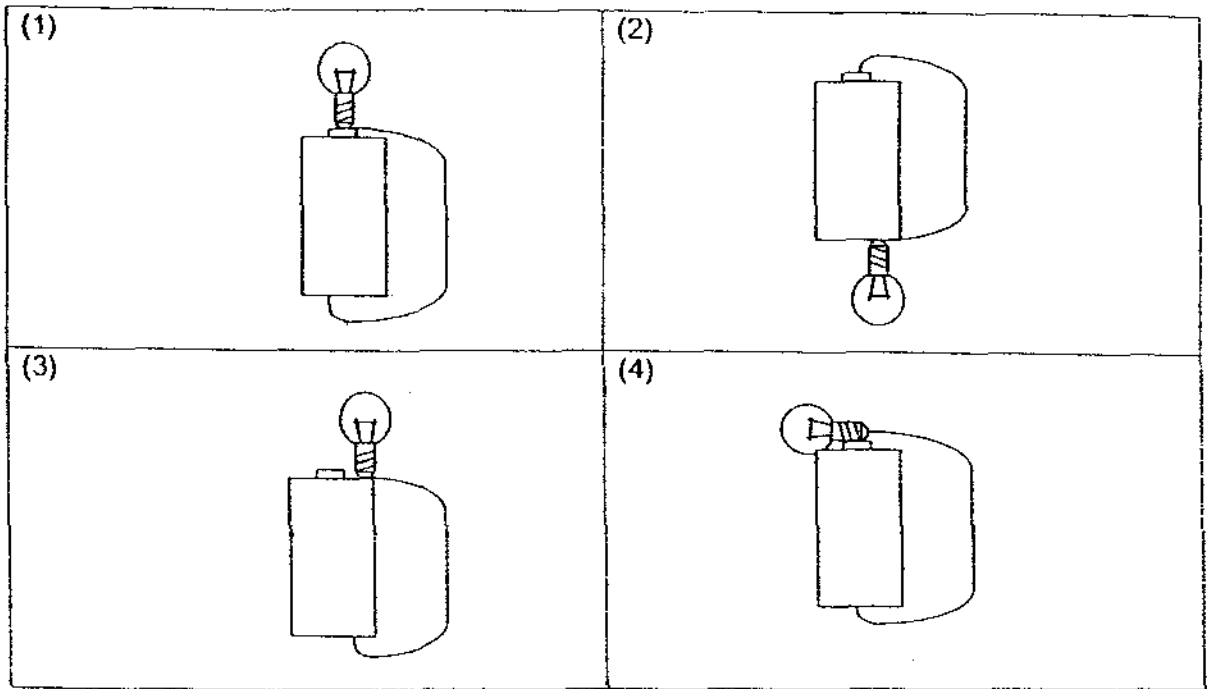

25 Study the circuit diagram below.

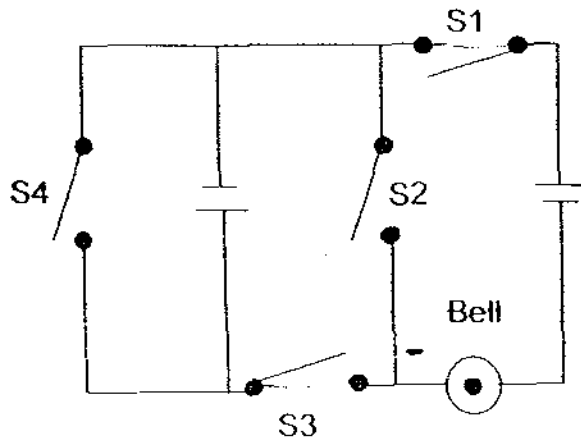

Which switch(es) must be closed in order for the bell to ring?

- (1) S1 only
- (2) S1 and S3 only
- (3) S2 and S4 only
- (4) S3 and S4 only

26 If all the switches are closed, which one of the following circuits would have the brightest bulb(s)?

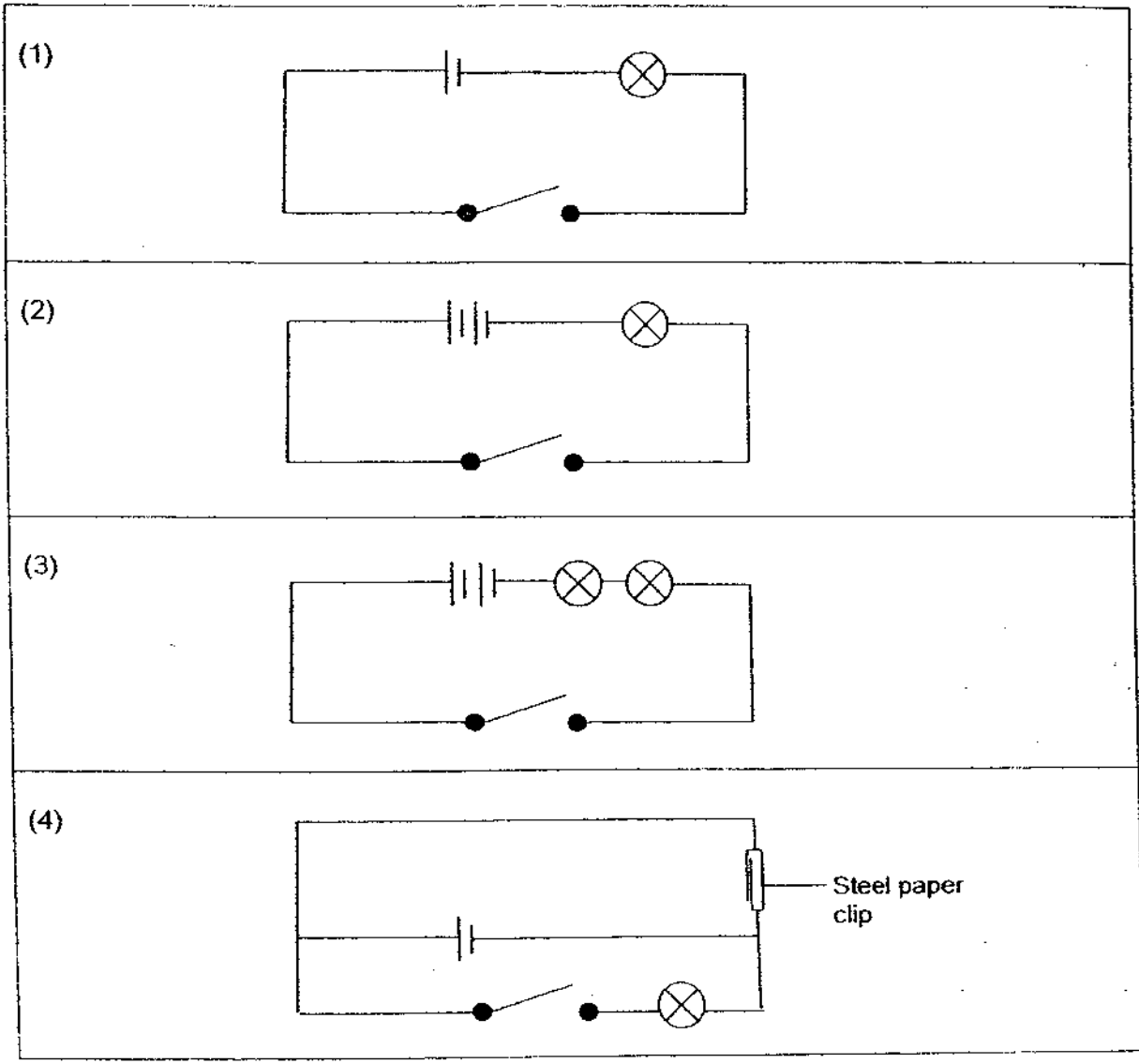

27 The table below shows the results observed when the circuit tester is tested with a particular circuit card.

Clips tested	Bulb in the circuit tester ...
A and B	lights up
A and C	lights up
A and D	does not light up
B and C	lights up
B and D	does not light up
C and D	does not light up

Circuit tester

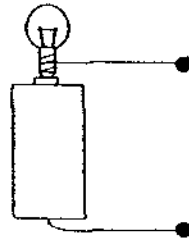

Which one of the four circuit cards below matches the above result?

<p>(1)</p>	<p>(2)</p>
<p>(3)</p>	<p>(4)</p>

- 28 Gary set up a circuit as shown in the diagram below. He connected 3 objects, one at a time, at the points P and Q.

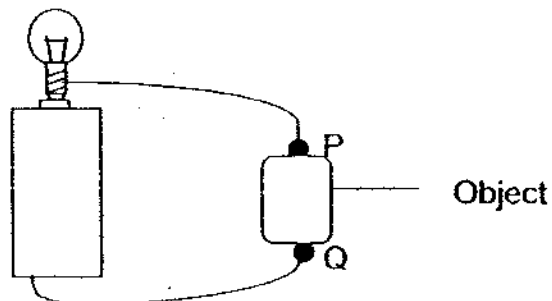

The table below shows the observations he made.

Object	Did the bulb light up?	Was the object hot?
A	Yes	No
B	No	No
C	Yes	Yes

Based on the observations, he made 4 conclusions.  
Which one of the following conclusions is **wrong**?

- (1) Object B is an insulator of electricity.
  - (2) Object C gives off less heat than Object A.
  - (3) Object A is a very good conductor of electricity.
  - (4) Object A allows the bulb to light up more brightly than Object C.
- 29 Which one of the following is a good conductor of electricity?

- (1) Lead
- (2) Wood
- (3) Glass
- (4) Plastic

30 Study the circuit below.

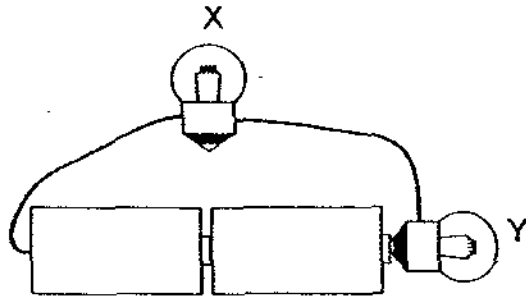

Which one of the following statements is **true**?

- (1) Bulb Y will not light up.
- (2) The bulbs are connected in parallel.
- (3) Electricity is passing through part of Bulb X.
- (4) The negative terminal of the battery is connected directly to bulb Y.



Anglo-Chinese School (Primary)

END-OF-YEAR EXAMINATION 2009  
SCIENCE  
BOOKLET B  
PRIMARY FIVE

Name: \_\_\_\_\_ ( ) Class: Primary 5 \_\_\_\_\_

Date: 2 November 2009

Duration of paper: 1h 45min

\_\_\_\_\_  
Parent's/Guardian's signature

**INSTRUCTIONS TO CANDIDATES**

1. This question paper consists of 14 printed pages.
2. Do not turn this page until you are told to do so.
3. Follow all instructions carefully.
4. Shade your answer on the Optical Answer Sheet (OAS) provided.

Booklet	Maximum marks	Marks obtained
A	60	
B	40	
Total	100	

## PART II

For questions 31 to 44, write your answers in this booklet.

The number of marks available is shown in brackets [ ] at the end of each question or part question.

(40 marks)

- 31 Viknesh wanted to find out if the material of container affects the rate of melting of ice. He carried out an experiment as shown below using ice cubes of the same size and supplying an equal amount of heat to each container. He left both set-ups at the same location.

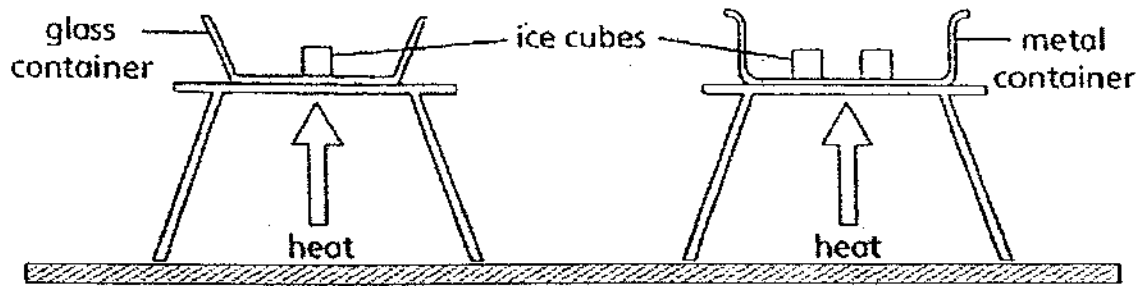

- (a) Viknesh's classmates claim that he did not carry out a fair test. [1]  
Explain why it is not a fair test.

\_\_\_\_\_

- (b) Explain what Viknesh must do to ensure that his experiment is a fair one. [1]

\_\_\_\_\_  
\_\_\_\_\_

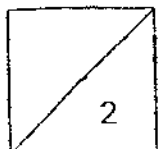

- 32 Anthony used the set-up below to heat some water until it boiled. The burner was turned on throughout the experiment.

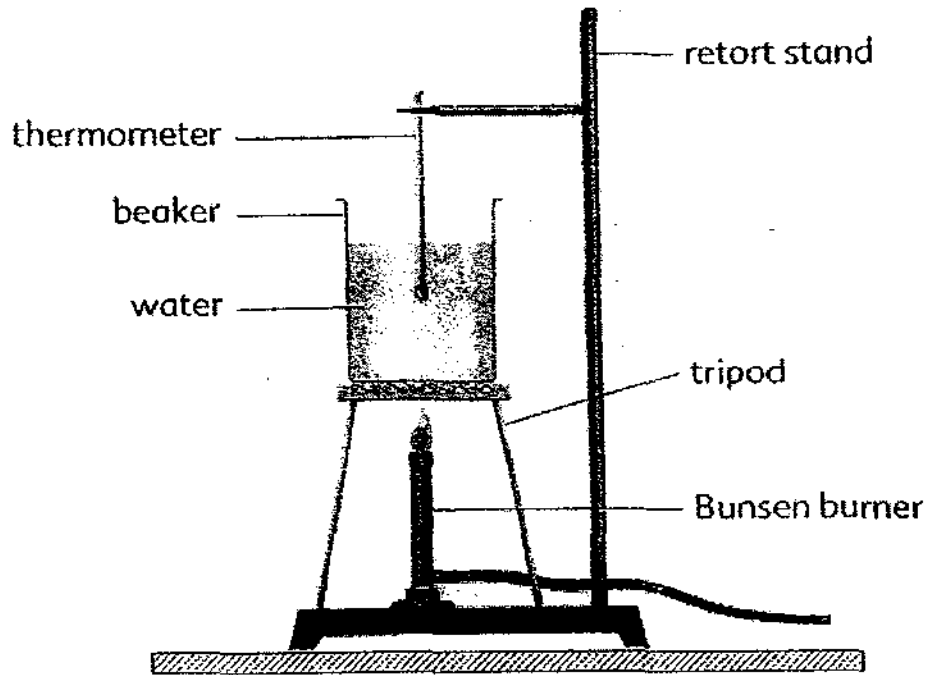

- (a) He then recorded the temperature of the boiling water. Fifteen minutes later, there were still some water left in the beaker. He then checked the reading on the thermometer again. [1]

What is the reading on the thermometer at this time?

---

- (b) Give a reason for your answer in part (a). [2]

---

---

- (c) Anthony observed some 'cloud' rising from the mouth of the beaker. What is this 'cloud' that he observed? [1]

---

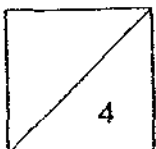

33 The diagram below shows one of the important systems in the human body.

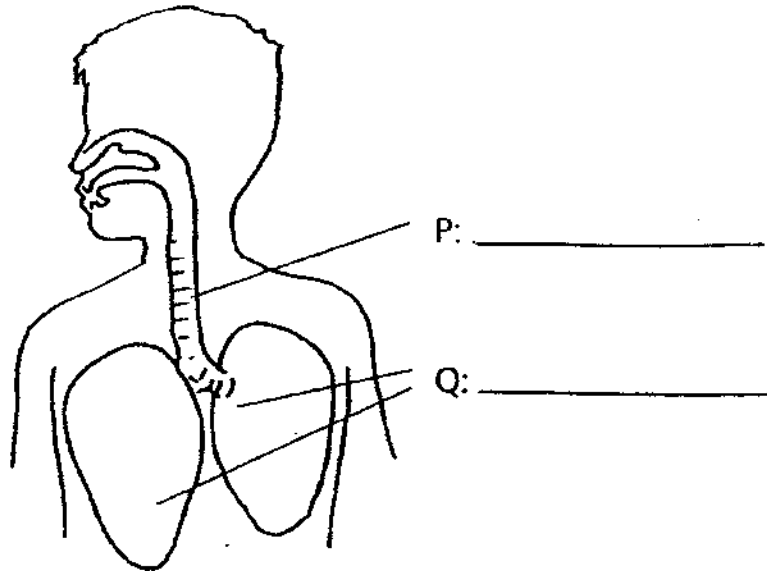

(a) Name the parts P and Q in the diagram above. [2]

(b) What human body system does the above diagram represent? [1]

---

(c) Name the part of the skeletal system that protects part Q. [1]

---

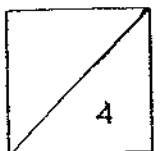

- 34 Jonathan used the set-up below to show the water cycle. He later observed that there were droplets of water formed at the underside of the plastic sheet and at the inner sides of the beaker.

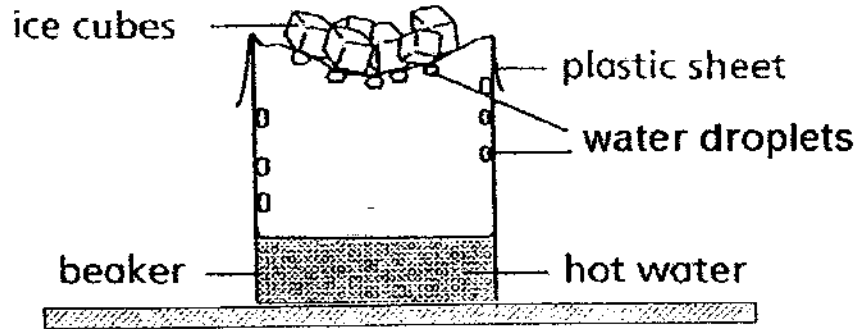

- (a) What is the purpose of putting ice cubes on the plastic sheet? [1]

---

---

- (b) State the 4 major changes that have led to the water droplets being formed. [2]

---

---

---

---

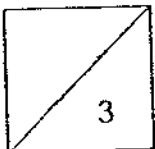

- 35 A group of environmentalists were studying the pollution levels of five rivers and set out to find out the water quality of the five rivers. The table below shows the results of their findings. A tick (✓) represents the presence of the characteristic of water and substances found in it while a cross (x) represents the absence of it.

River	Substances found in river		Characteristic of water	
	Oil	Litter	Odour	Cloudy
P	x	x	✓	✓
Q	x	✓	✓	✓
R	✓	✓	✓	✓
S	✓	x	✓	x
T	x	x	x	x

- (a) From the above information, which river is most likely to be the least polluted? [1]

---

- (b) The environmentalists made a further study and found out that the number of water plants and other living things found dead were particularly high in River R and S. [2]

Based on the information in the table above, suggest a common possible explanation for this.

---



---

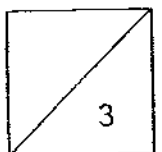

- 36 Stuart sets up the experiment as shown in the diagram below. There is an ink indicator in the glass tube. He then put the test tube into a beaker of hot water. Stuart observed that the ink indicator in the glass tube dropped a little at first and then rose.

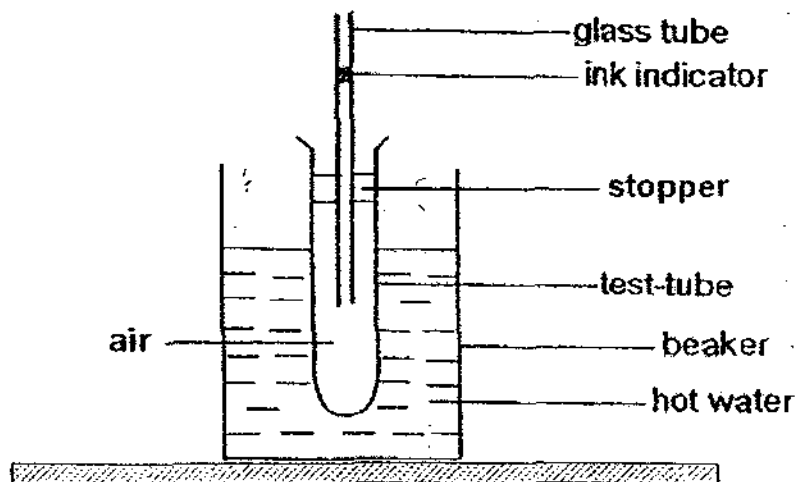

- (a) Explain why the ink indicator in the glass tube dropped a little at first. [1]

---

---

- (b) Explain why the ink indicator in the glass tube rise after it dropped. [1]

---

---

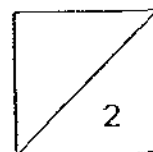

- 37 Julie wanted to find out if the temperature of water would affect how fast biscuits soften. She put a biscuit into a cup of water at 30°C as shown below.

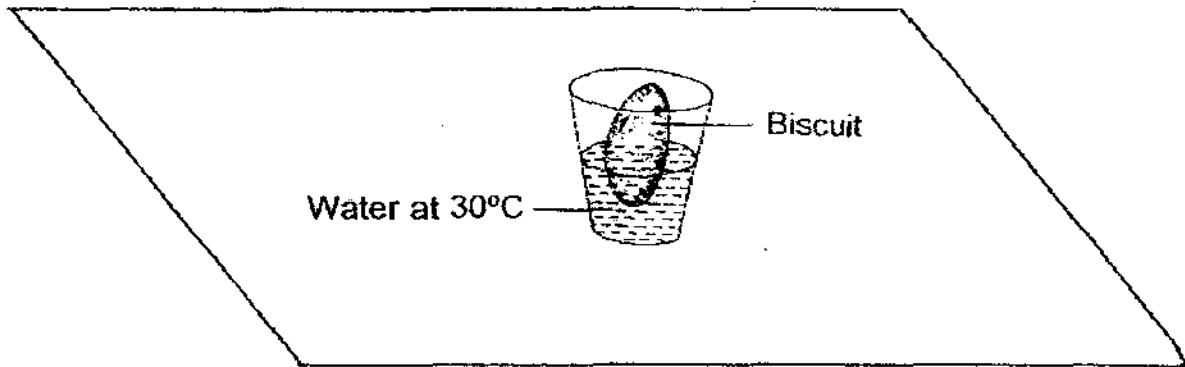

After 5 minutes, she removed the biscuit, observed it and recorded her observation. The following is the list of variables that she had to either change or keep constant. Put a tick (✓) in the correct box in the table below to ensure that a fair test experiment was conducted. [2]

Variables	To be changed	To be kept constant
Type of biscuit		
Amount of water		
Temperature of water		
Duration biscuit was placed in water		

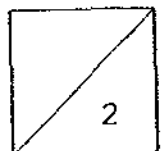

38 Study the classification flow chart below.

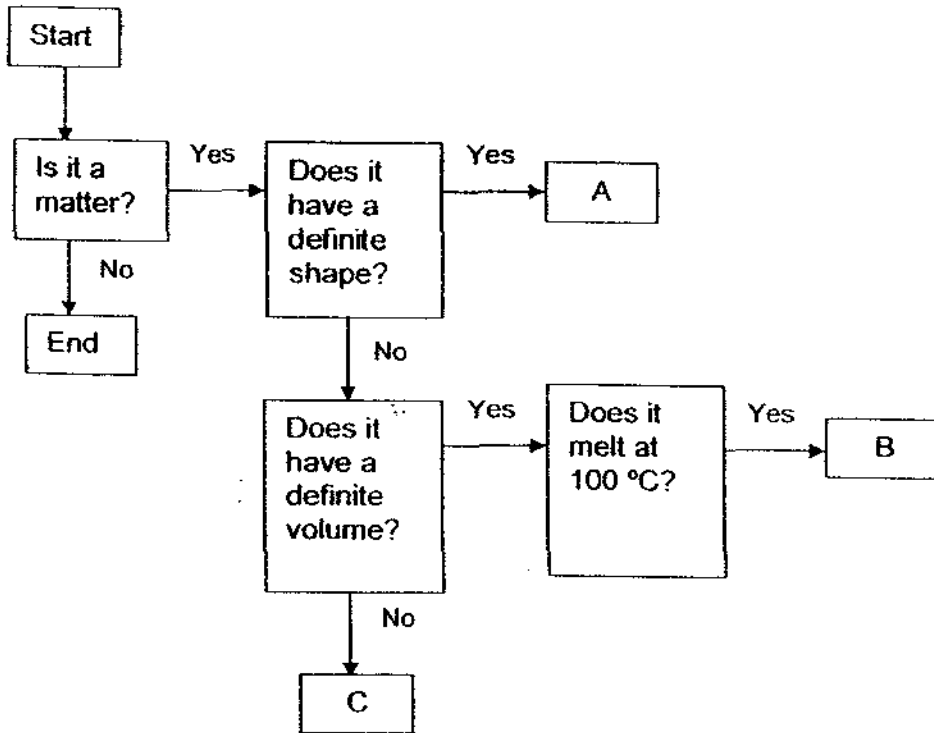

(a) Based on the classification flow chart above, how is A different from B? [1]

---

---

(b) Give an example of C. [1]

---

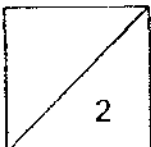

39 Each of the glass containers below contained 125 ml of water. They were left by a window for a period of time and after which, the amount of water left was measured.

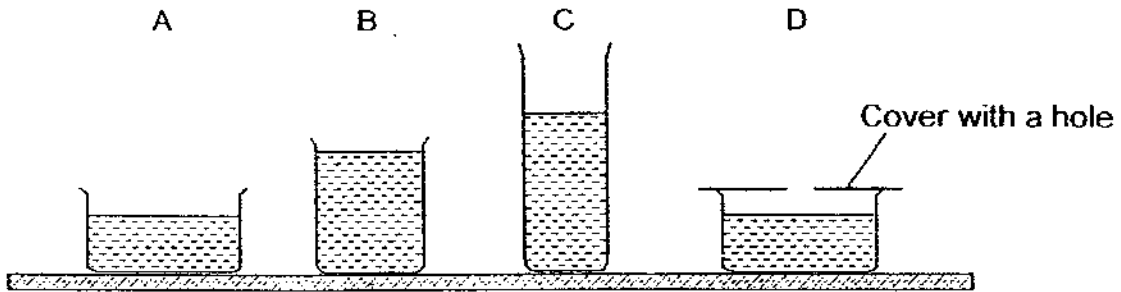

(a) List the two variables that were changed in the experiment above. [1]

- i) \_\_\_\_\_
- ii) \_\_\_\_\_

(b) Draw bar graphs to predict the possible amount of water in each container at the end of the experiment. [1]

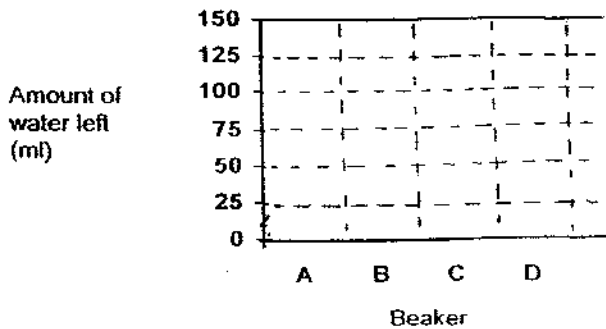

(c) The aim of experiment was to find out how exposed surface area affects the rate of evaporation. Use a pencil and ruler to draw the covers for set-ups F, G and H below. [1]

E F G H [1]

Cover with a hole

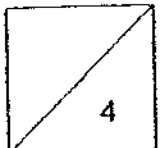
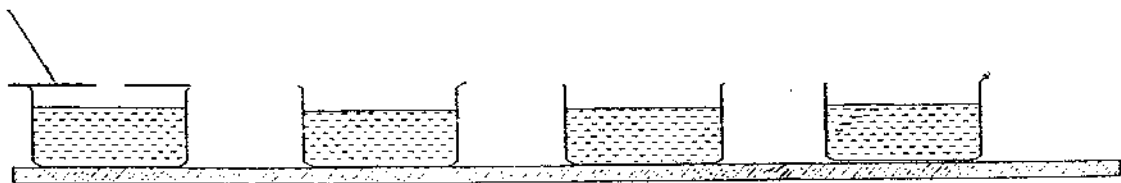

- 40 Mrs Smith wants to find out the most suitable material for making a curtain to keep her room shady. She has material A, B and C. The experiment was conducted in the same room using the same torchlight. The diagram below shows her set-up.

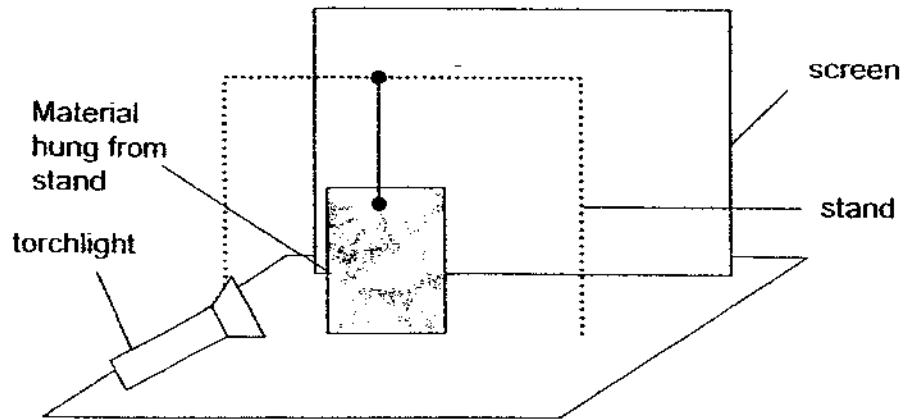

- (a) Besides the size and thickness of the material, give another variable that is needed to be kept constant. [1]

---

- (b) What should she look out for so that she can choose the most suitable material to be made into the curtain? Explain your answer. [1]

---



---

Mrs Smith then painted 2 different designs on material A, design 1 and design 2, as shown in the diagram below. Each design has the same thickness and colour. The diagrams below are sample rectangular cuts from each piece.

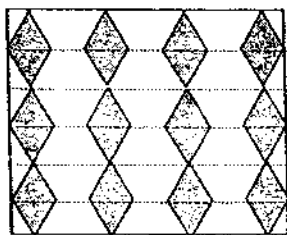

Design 1 printed on material A

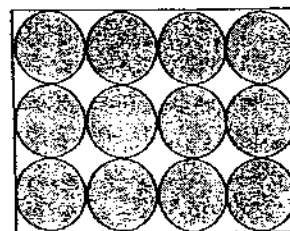

Design 2 printed on material A

- (c) Which design (design 1 or design 2) would be more suitable for making a curtain to keep Mrs Smith's room shady? Why? [2]

---



---

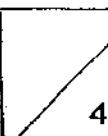

41 The diagram below shows the side view of the objects used in an experiment.

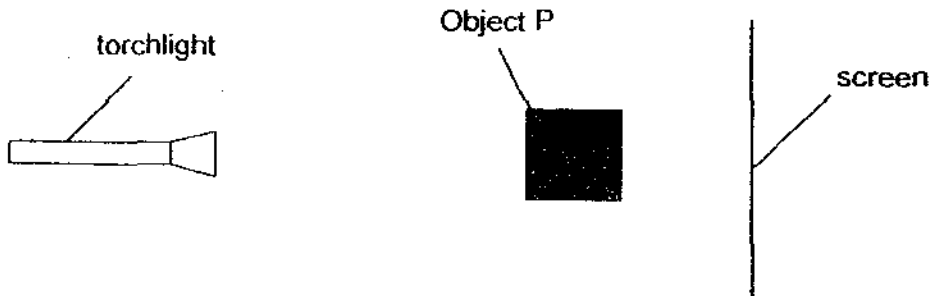

The 3 dimensional (3D) front view of object P is shown below.

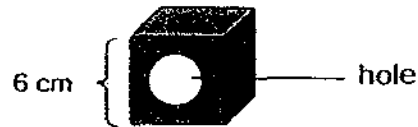

- (a) When the light source is switched on, a shadow of the object is cast on the screen. [1]  
 Draw the shadow of object P in the box below.

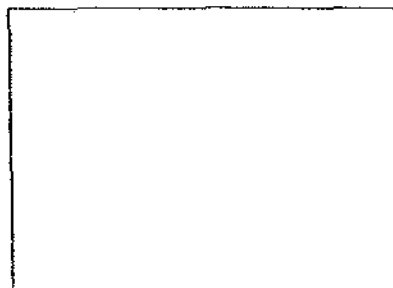

- (b) If the height of object P is 6 cm and it is positioned 5 cm away from the screen, [1]  
 what would be the estimated height of the shadow cast on the screen?

---

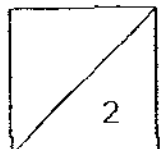

42 Study the family tree below.

Key  represents male       represents female

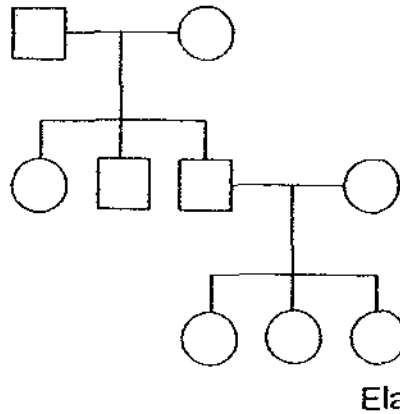

(a) How many generations are represented in this family tree? [1]

(b) Ela's aunt is married and has 2 daughters. Construct by adding this information into Ela's family tree above. [2]

43 Draw a closed circuit diagram using 1 battery, 1 switch and 2 bulbs in the box below. The bulbs should be connected in a parallel arrangement and they must be able to light up. [2]

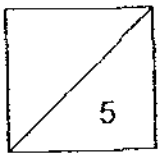
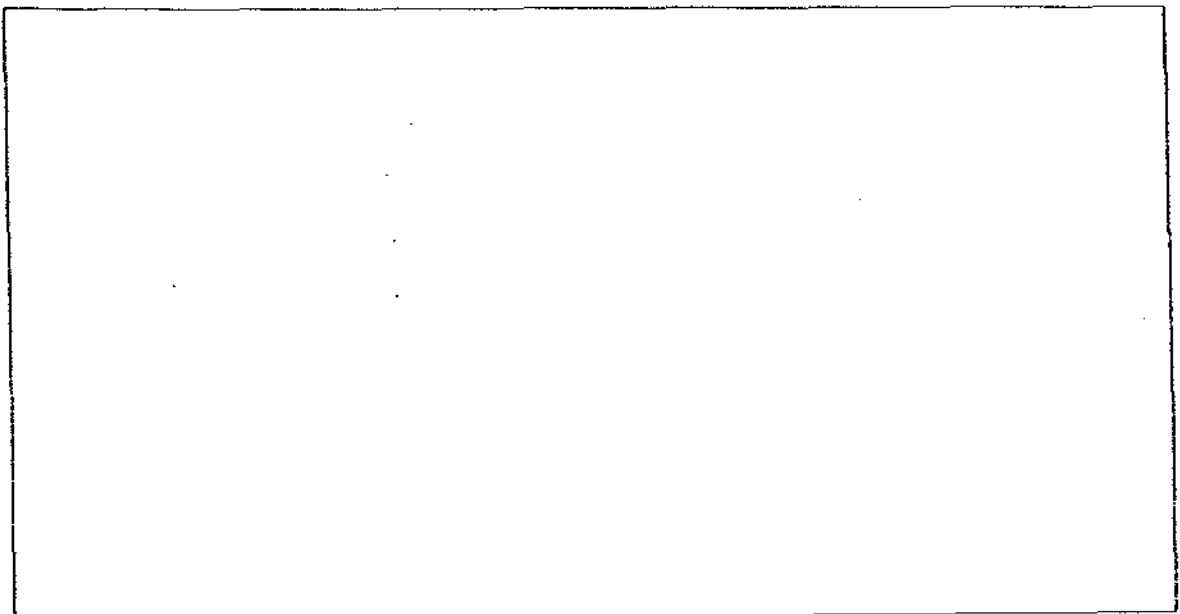

44 Bala set up an experiment as shown in the diagram below.

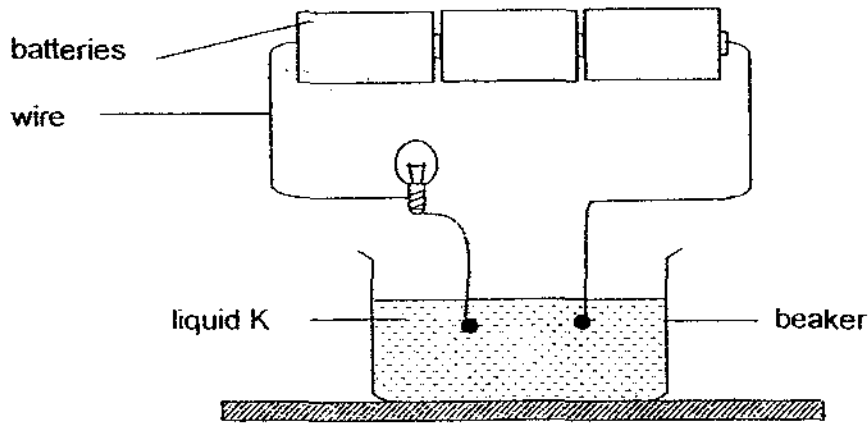

(a) If the bulb lights up, what does it tell you about liquid K?

[1]

Bala repeated the experiment but now, he attached a coil of copper wire at the 2 ends as shown in the diagram below.

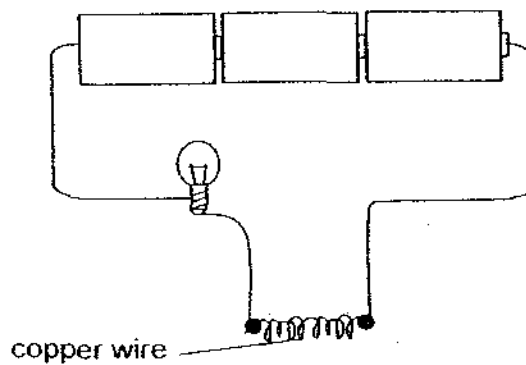

(b) What will happen to the bulb and copper wire at the end of 5 minutes?

[2]

---

---

- End of Paper -

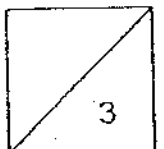

# ANSWER SHEET

**EXAM PAPER 2009**

**SCHOOL : ACS PRIMARY**  
**SUBJECT : PRIMARY 5 SCIENCE**

**TERM : SA2**

Q1	Q2	Q3	Q4	Q5	Q6	Q7	Q8	Q9	Q10	Q11	Q12	Q13	Q14	Q15	Q16	Q17
4	2	3	2	2	2	3	1	2	3	2	4	4	2	3	2	4

Q18	Q19	Q20	Q21	Q22	Q23	Q24	Q25	Q26	Q27	Q28	Q29	Q30
2	4	2	2	1	3	4	2	2	1	2	1	3

**31)a)The one in the glass container has only 1ice cube while the one in the metal container has 2 ice cubes.**

**b)He should use the same number of ice cubes and containers with the same exposed surface area.**

**32)a)100°C**

**b)Water boils at 100°C and the temperature cannot go over 100°C.**

**c)Water droplets.**

**33)a)P: wind pipe. Q: lungs**

**b)The respiratory system.**

**c)The ribcage.**

**34)a)The test tube expands first when comes into contact with hot water, so the ice is more space for air.**

**b)The water gains heat and evaporate into water vapour, when the water vapour comes into contact with the cool plastic sheet it loses heat and condenses into water droplets.**

**35)a)River T.**

**b)They do not get oxygen nor do they get carbon dioxide. The fishes will die due + lack of oxygen. The plants will die due to lack of oxygen and carbon dioxide as the oil is covering the layer of water so air cannot go in.**

**36)a)The hot water caused the test-tube to expand. Thus, having more space, the ink indicator dropped.**

**b)The hot water heated up the air in the test-tube and it expanded.**

37) Type of biscuit-----To be kept constant  
 Amount of water----- To be kept constant  
 Temperature of water--- To be changed  
 Duration biscuit was placed in water-----To be kept constant

38)a) A has definite shape while B does not have a definite shape.  
 b) Steam.

39)a) i) Exposed surface area.  
 ii) Height of beaker.

b)

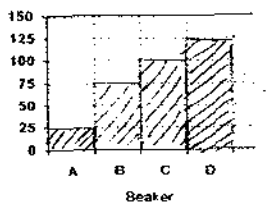

c)

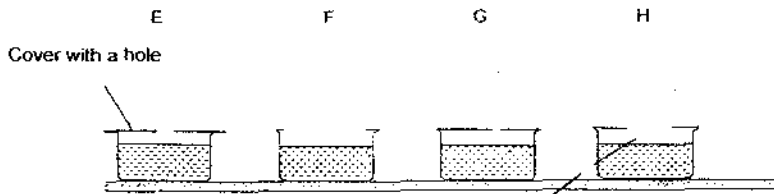

40)a) The distance between the screen and the stand.

b) To look out for how light shadow is. The darker the shadow is, the more suitable is the material vice versa.

c) Design 2. It blocks out more light than design 1 as it has a larger exposed surface area.

41)a)

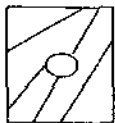

b) 8cm

42)a) 3 generations.

b)

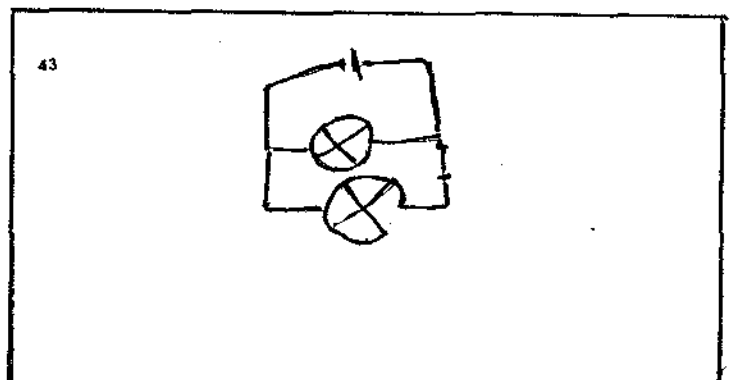
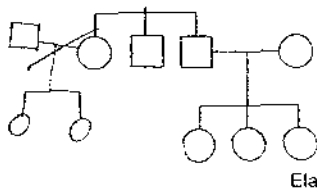

44)a) It is a conductor of electricity.

b) The wire will heat up and the bulb will light up.