

**CATHOLIC HIGH SCHOOL
PRIMARY 5
SEMESTRAL EXAMINATION 2
2009**

SCIENCE

Name: _____ ()

Class : Primary 5 _____

Date : 29 October 2009

BOOKLET A

30 Questions
60 Marks

Total Time for Booklets A & B : 1 hour 45 minutes

Instructions to Candidates

Do not open this booklet until you are told to do so.
Follow all instructions carefully.
Answer all questions.

Section A : Multiple Choice Questions (60 marks)

For each question from 1 to 30, four options are given. One of them is the most suitable answer. Make your choice (1, 2, 3 or 4) on the Optical Answer Sheet.

1. Which of the following statements is/are true for all living things?

- A They lay eggs.
- B They respond to changes.
- C They breathe through lungs.
- D They inherit their parents' genetic information.

- (1) A and C only
- (2) B and D only
- (3) A, B and D only
- (4) B, C and D only

2. Study the classification table below.

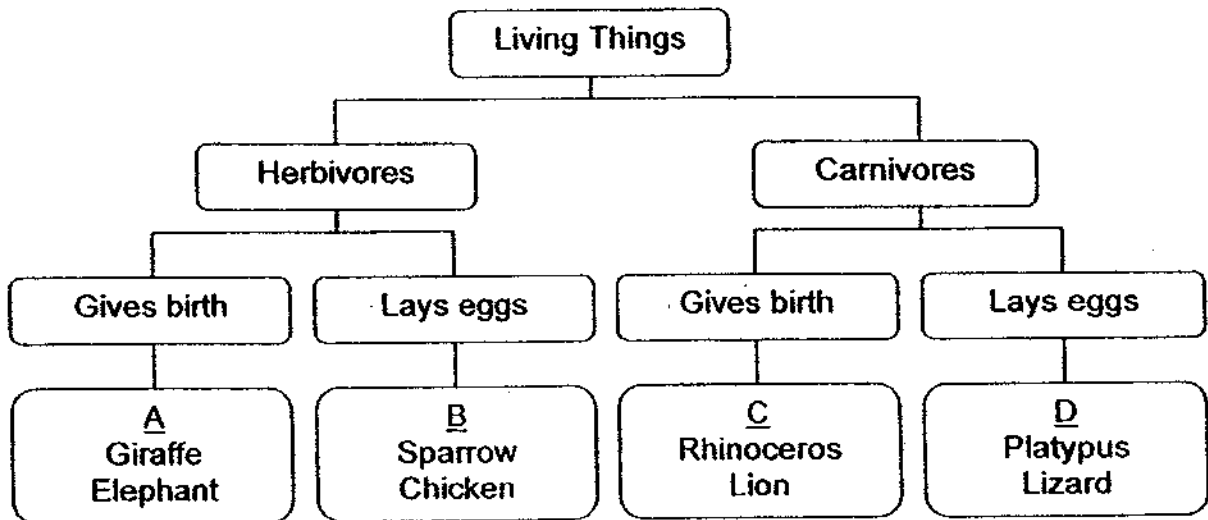

Which groups of animals are wrongly classified?

- (1) A and B only
- (2) B and C only
- (3) C and D only
- (4) A and D only

3. Julia observed 3 animals, L, M and N. She drew a table and placed a tick (✓) in the box when she made the observation. At the end of the observation, the completed table is as follows.

Observation	Animal L	Animal M	Animal N
4 stages in the life cycle	✓		
Gives birth to young alive		✓	
Young resembles the adult		✓	✓
Moults several times at one stage of its life cycle	✓		✓

Which of the following could be Animals L, M and N?

	Animal L	Animal M	Animal N
(1)	cockroach	giraffe	butterfly
(2)	cockroach	butterfly	giraffe
(3)	butterfly	giraffe	cockroach
(4)	butterfly	cockroach	giraffe

4. Which one of the following diagrams shows the correct order in the life cycle of a flowering plant?

(1)

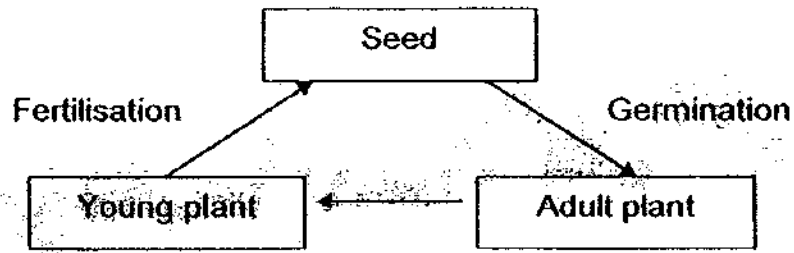

(2)

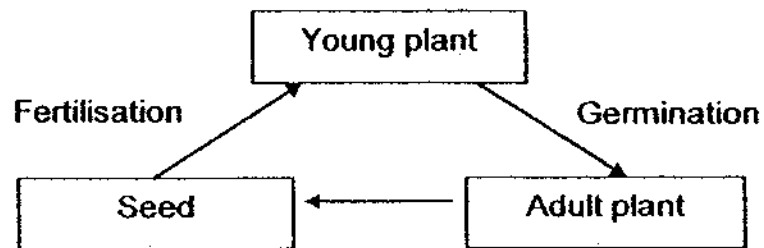

(3)

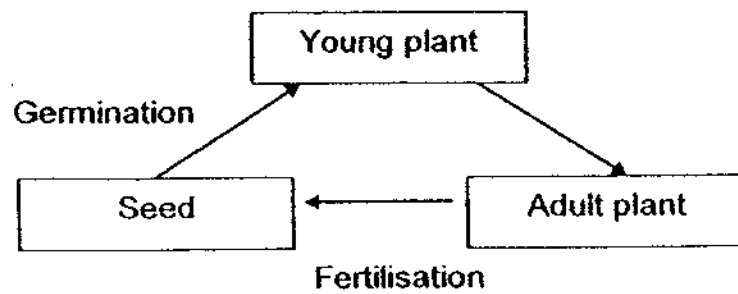

(4)

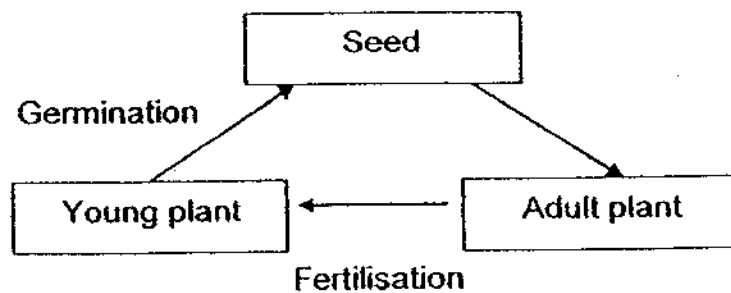

5. The flow chart below shows the processes involved in the human digestive system.

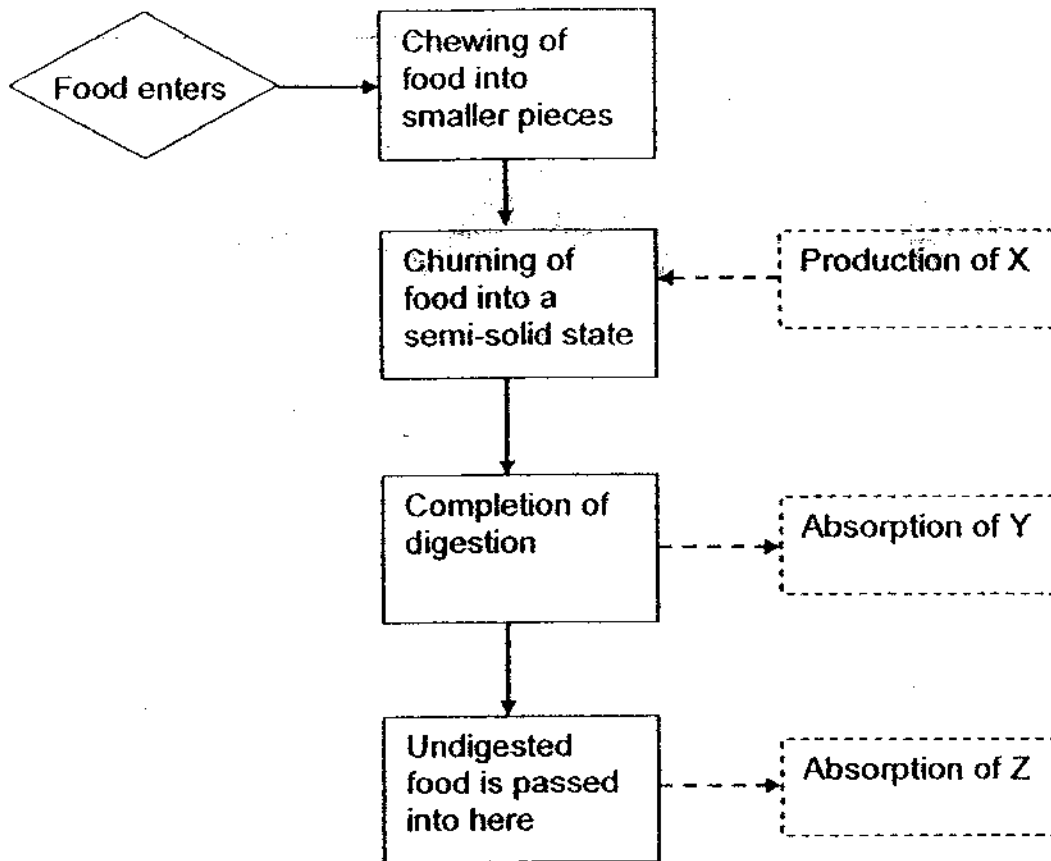

Based on the information given in the flow chart, what are X, Y and Z?

	X	Y	Z
(1)	Saliva	Nutrients	Water
(2)	Saliva	Water	Nutrients
(3)	Digestive juice	Water	Nutrients
(4)	Digestive juice	Nutrients	Water

6. The diagram below shows four magnets, P, Q, R and S.

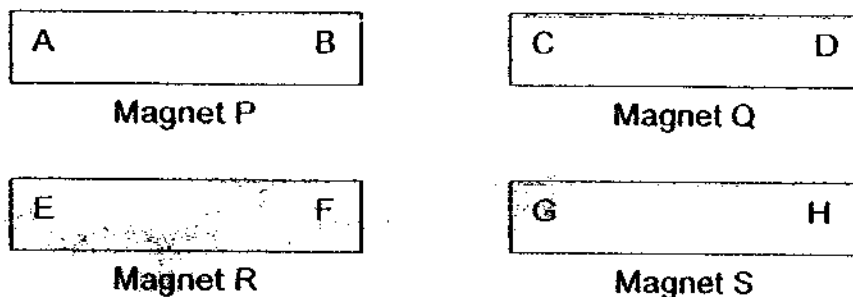

A test was carried out with the four magnets and the results are shown in the table below.

A and D	Attracts
A and E	Repels
G and B	Attracts
G and C	Repels

Which one of the following pairs of poles will repel each other?

- (1) A and G
 - (2) B and C
 - (3) C and H
 - (4) D and E
7. The diagram below shows a water container filled with 2000 cm^3 of water. The capacity of the container is 5000 cm^3 .

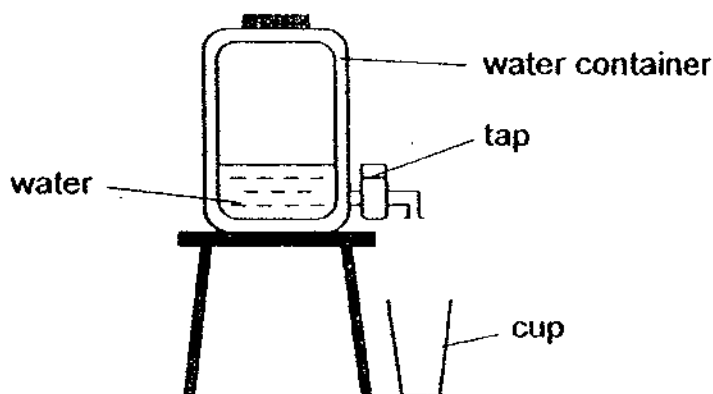

The tap of the container is turned on and 250 cm^3 of water was released into the cup.

What is the remaining volume of air in the container?

- (1) 3250 cm^3
- (2) 3000 cm^3
- (3) 2750 cm^3
- (4) 2500 cm^3

8. Daniel set up two experiments using funnels, beakers and a straw as shown in the diagram. Stoppers were used to hold the funnels and straw in place and water was poured gradually into the funnels.

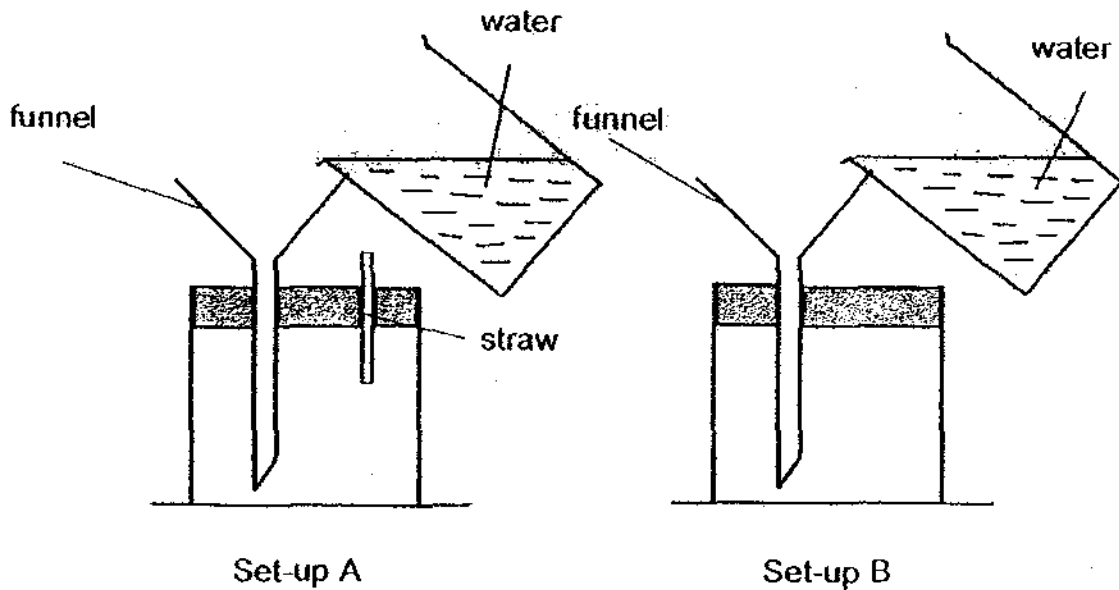

Which one of the following statements would best describe what he observed?

- (1) No water flows through the funnel in set-up A.
 - (2) No water flows through the funnel in set-up B.
 - (3) Less water is collected in set-up A than set-up B.
 - (4) Less water is collected in set-up B than set-up A.
9. Laura looked through a paper tube as shown below.

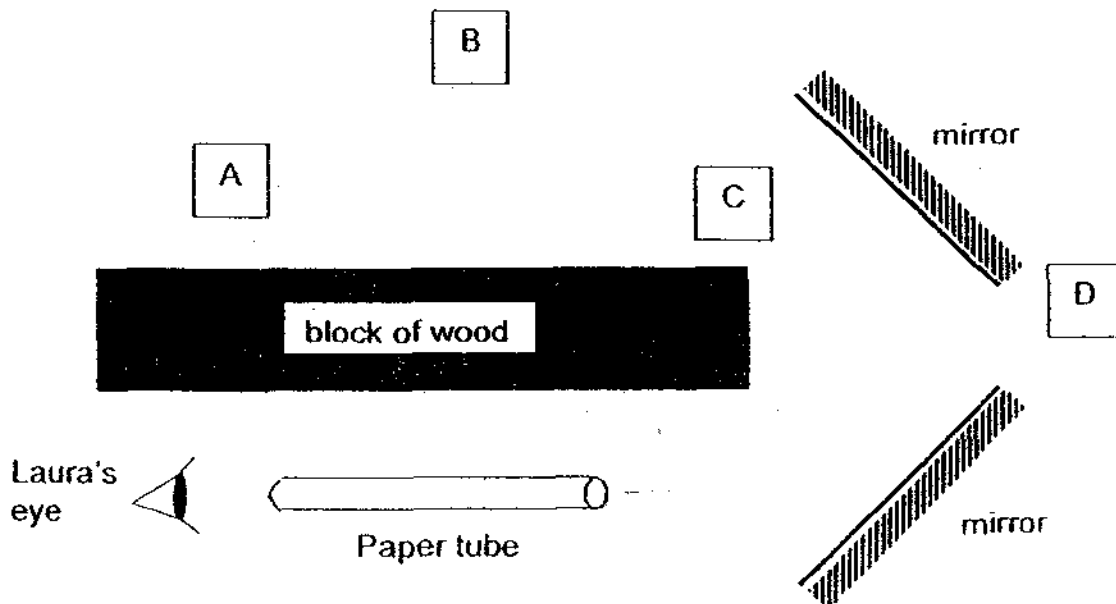

From the diagram above, which box/es will Laura see?

- (1) C only
- (2) D only
- (3) B and C only
- (4) A, C and D only

10. Jess conducted an experiment to investigate the amount of light that can pass through three materials of the same thickness. The materials he used were tracing paper, clear glass and plywood. He shone a torch through the three materials. He used a light sensor to measure how much light has passed through each of them.

He drew a graph to show the amount of light recorded by the light sensor. Which one of the following graphs is correct?

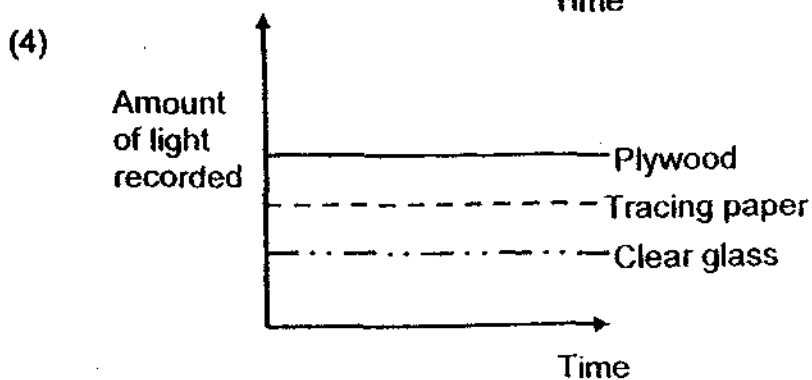
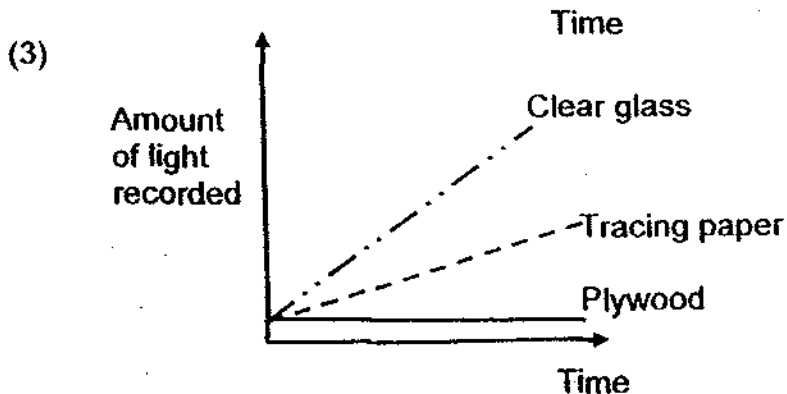
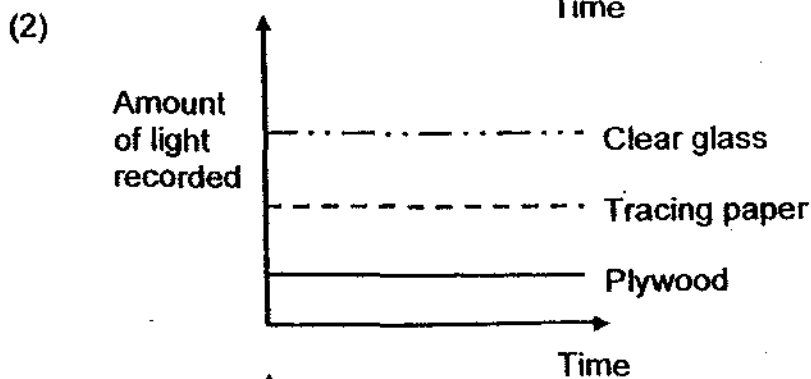
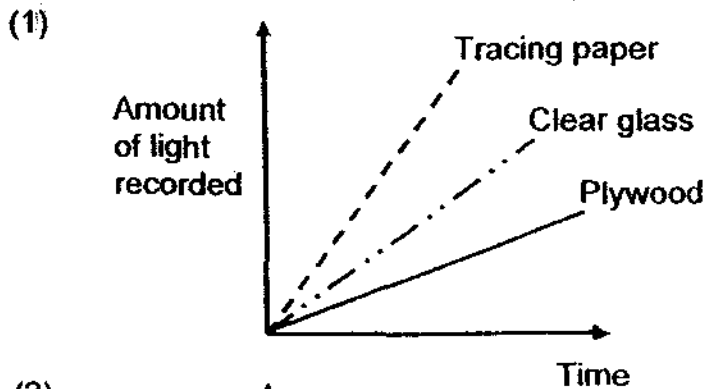

11. Dawn set up the experiment shown below using four identical cups. She left the experiment for 5 minutes and then checked the temperature of the water in each cup.

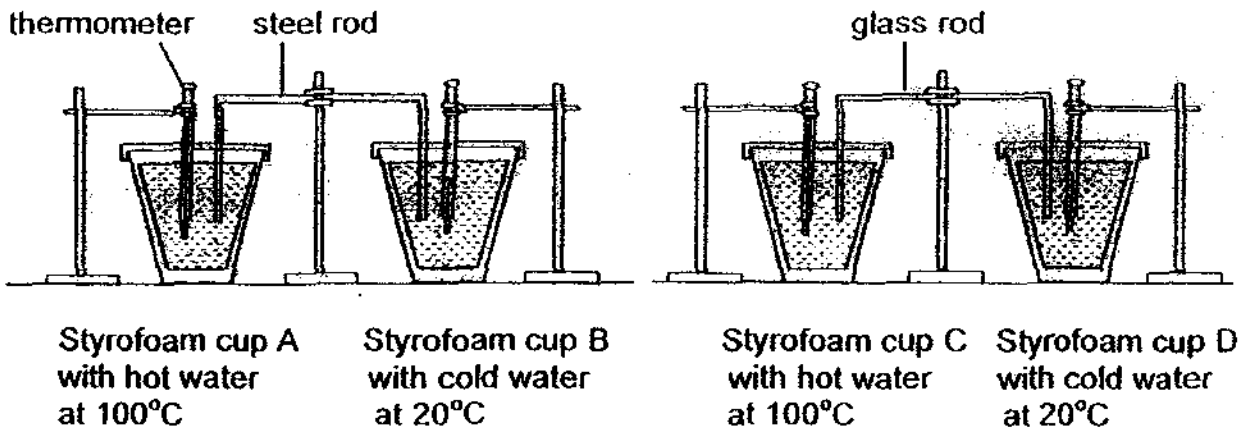

Arrange the cups, A, B, C and D from the coolest to the hottest after 5 minutes.

- (1) A, C, D, B
- (2) D, B, A, C
- (3) B, D, C, A
- (4) C, A, B, D

12. Four cans of similar size and thickness are filled with the same amount of boiling water. The cans are made of wood, aluminium, glass and styrofoam. Each can is covered with a lid made of the same material as the can and the temperature of the water in each can is measured over a period of 15 minutes.

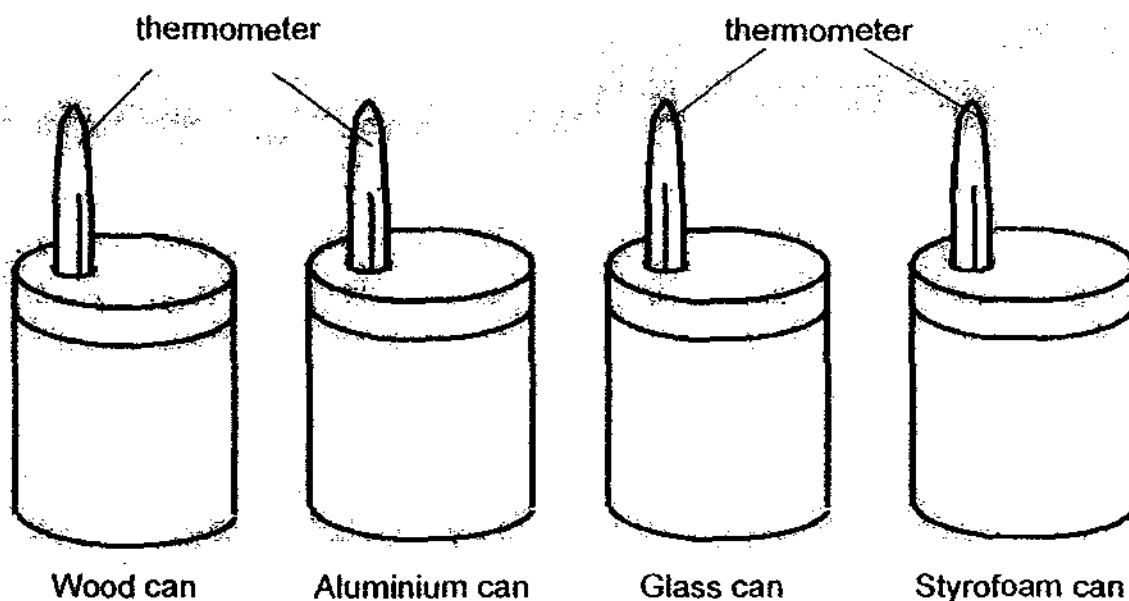

The graph below shows the temperature of the water in each can over the period of 15 minutes.

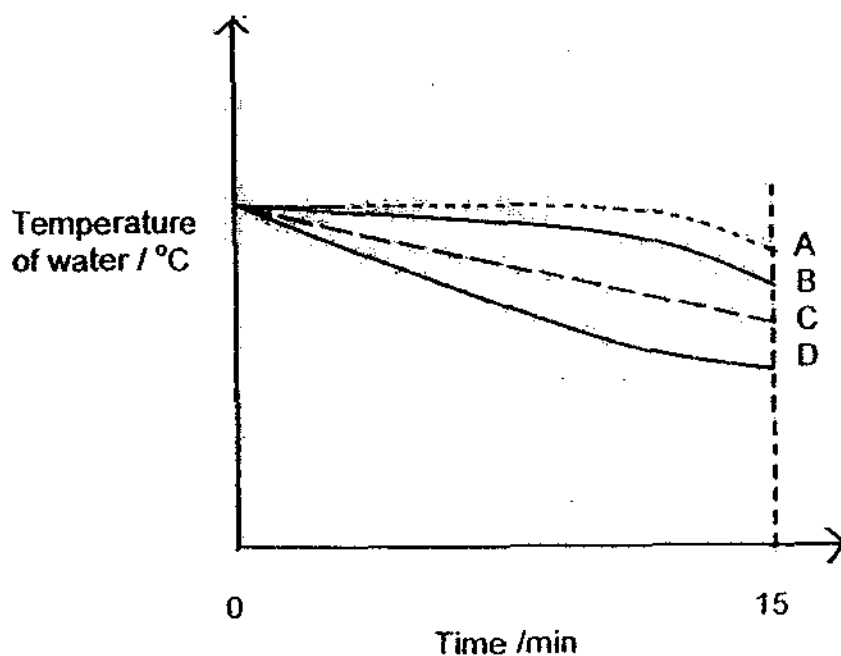

Which graph, A, B, C or D would represent the temperature of the water in the aluminium can over the period of 15 minutes?

- (1) A
- (2) B
- (3) C
- (4) D

9b

13. Mary placed a green plant outdoors on a sunny day. Which graph correctly represents the plant's rate of photosynthesis?

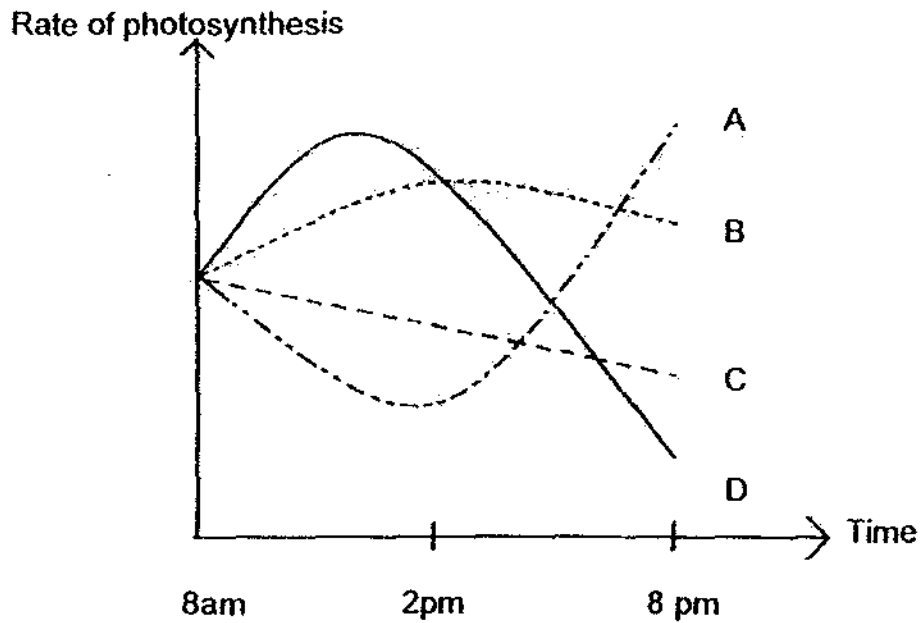

- (1) A
- (2) B
- (3) C
- (4) D

14. Study the energy chain below carefully.



Which one of the following correctly traces the percentage of Sun's energy transferred at the various stages in the energy chain?

Percentage of Sun's energy transferred at various stages				
	A	B	C	D
(1)	1%	0.1%	10%	100%
(2)	1%	10%	0.1%	100%
(3)	100%	10%	0.1%	1%
(4)	100%	10%	1%	0.1%

15. The diagram below shows how sugar and water are transported to and from different parts of a plant.

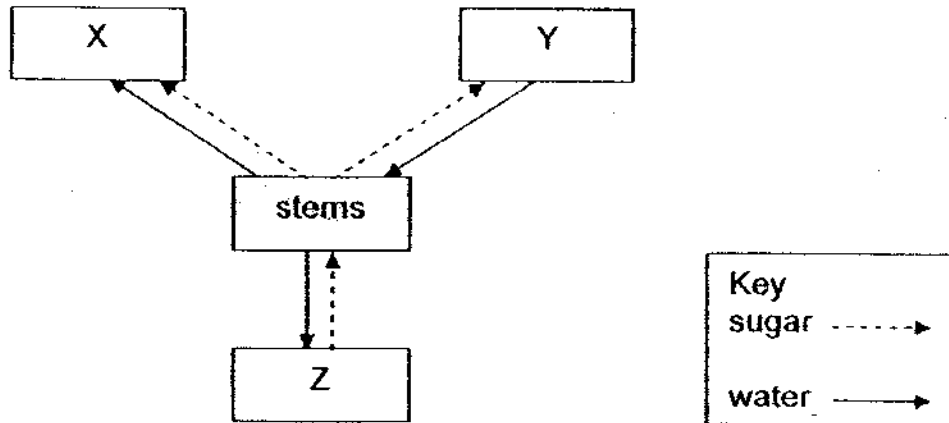

Which one of the following shows the parts of the plant that are represented by X, Y and Z correctly?

	X	Y	Z
(1)	leaves	fruit	roots
(2)	fruit	roots	leaves
(3)	roots	fruit	leaves
(4)	roots	leaves	fruit

16. The arrows, A, B, C and D represent blood vessels carrying blood to and from the heart, lungs and other parts of the body.

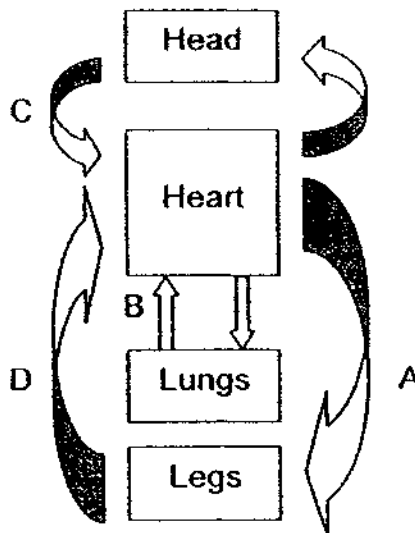

Which two blood vessels carry blood with more carbon dioxide?

- (1) A and B
(2) A and C
(3) B and C
(4) C and D

17. Jason was told by his teacher that the blood in our body has more than one function. Which of the following are the functions of the blood?

- A It sends messages to the brain.
- B It transports oxygen and carbon dioxide to and from the heart.
- C It transports digested food, water and waste materials in our body.

- (1) A only
- (2) B only
- (3) A and B only
- (4) B and C only

18. The diagram below shows the human respiratory system.

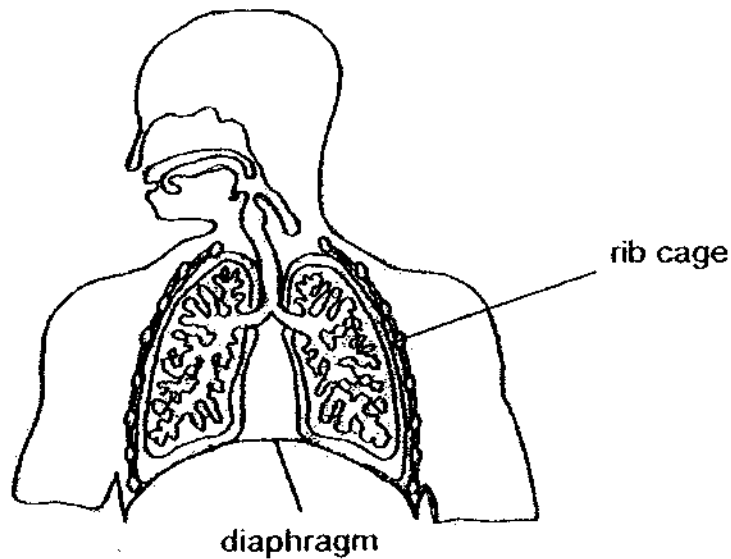

Which of the following shows the correct movements of the ribs and the diaphragm during inhalation and exhalation?

		Ribs		Diaphragm	
		Inhalation	Exhalation	Inhalation	Exhalation
(1)	up and outwards	down and inwards	relaxes	contracts	
(2)	up and outwards	down and inwards	contracts	relaxes	
(3)	down and inwards	up and outwards	relaxes	contracts	
(4)	down and inwards	up and outwards	contracts	relaxes	

19. Timothy and his friends prepared 3 set-ups and placed them in an open field from 7 am to 7 pm. They monitored the concentration of oxygen in the set-ups every hour.

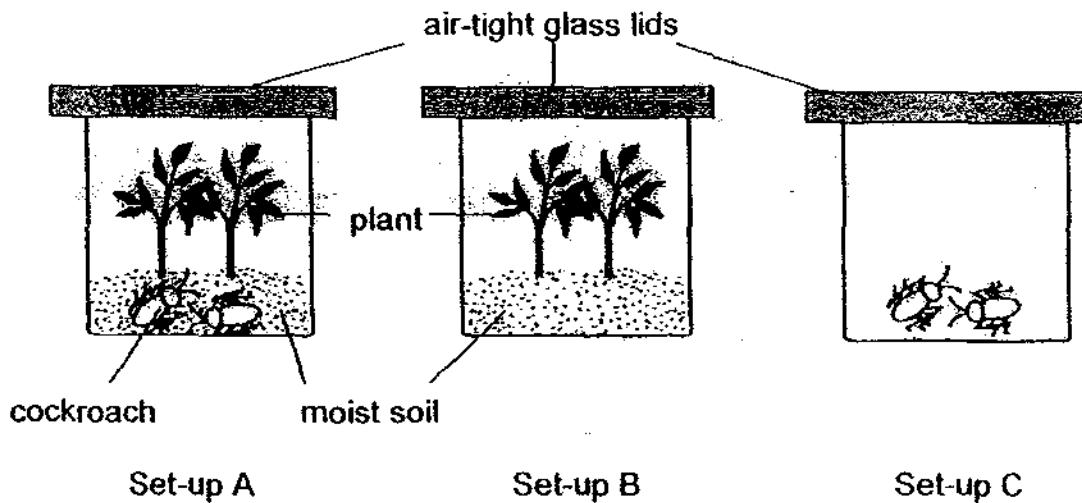

At the end of the investigation, his friends made the following conclusions.

- Ray There was an equal amount of oxygen at 2 pm in all three set-ups.
 Chris Set-up A had the most amount of oxygen at the end of the experiment.
 Linda There was more oxygen in Set-up B than A at the end of the experiment.

Which of Timothy's friend/s was / were correct?

- (1) Ray only
 - (2) Linda only
 - (3) Linda and Chris only
 - (4) Chris and Ray only
20. Mouth-to-mouth resuscitation is being carried out to save a man found face down in a swimming pool.



Which one of the statements is not true?

- (1) The man is trying to help the victim to breathe.
- (2) Air containing oxygen is being blown into the victim's lung.
- (3) Oxygen has to get into the victim's lungs as soon as possible.
- (4) The man is sucking up the water that has entered the victim's lungs.

21. The table below provides information on three types of cells, P, Q and R. A tick (✓) indicates the presence of the part of the cell.

Parts of Cell	Cell P	Cell Q	Cell R
chloroplast		✓	
nucleus	✓	✓	✓
cell wall		✓	✓

Which of the cell(s) is/are most likely to be found in the root of a plant?

- (1) P only
 - (2) R only
 - (3) P and Q only
 - (4) Q and R only
22. Mrs Tan's class watched a documentary on the development of a foetus in its mother's womb.

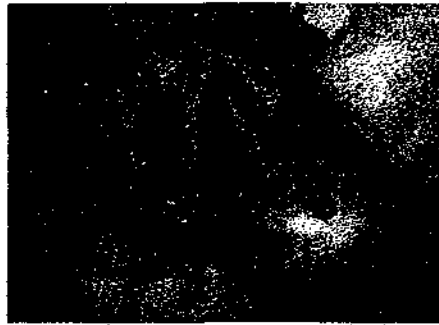

After the programme, four boys made the following comments about the foetus shown above.

- Alvin It does not require any water.
- Ben It is inside its mother's stomach.
- Jason It does not breathe through its nose.
- Wayne It depends on its mother for nutrients.

Which of the above boys made the correct remarks?

- (1) Alvin and Ben only
- (2) Jason and Wayne only
- (3) Alvin, Ben and Jason only
- (4) Alvin, Jason and Wayne only

23. The diagram below shows Kenny's family tree of 4 generations that carry the genetic trait for a disease, D. Study the family tree carefully and answer the following question.

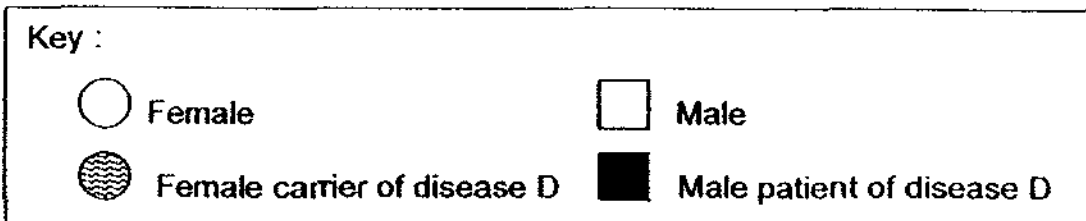
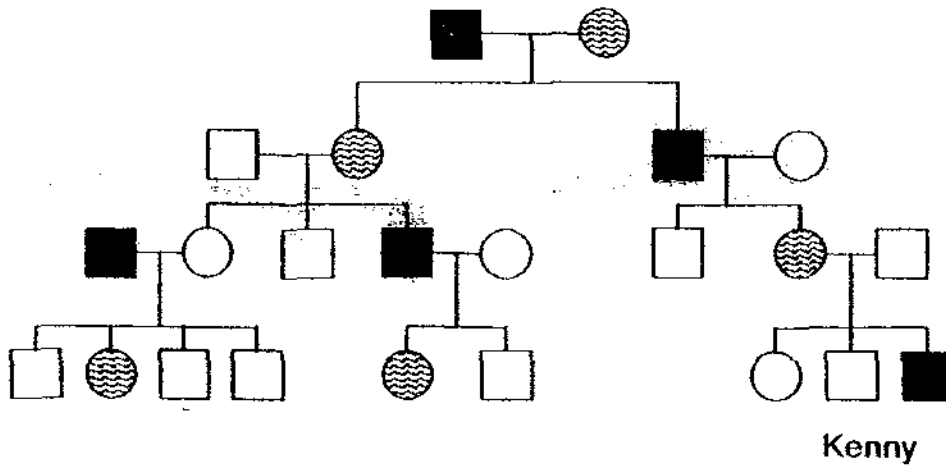

Which of the following statements are conclusions you can draw about the above family tree?

- A Disease D is passed on to only the male members of the family.
- B There is a chance that Kenny's sister may bear a son with the disease.
- C The daughter of a male patient with Disease D will be a carrier of the disease.
- D Kenny's mother inherited the genes of Disease D from her maternal grandmother.

- (1) A and C only
- (2) A and D only
- (3) B and C only
- (4) A, B and C only

24. Three different types of plants, P, Q and R were found on a piece of empty land with a river flowing downstream as shown in Figure 1. All of them bore fruits. A few years later, more of the plants were found as shown in Figure 2.

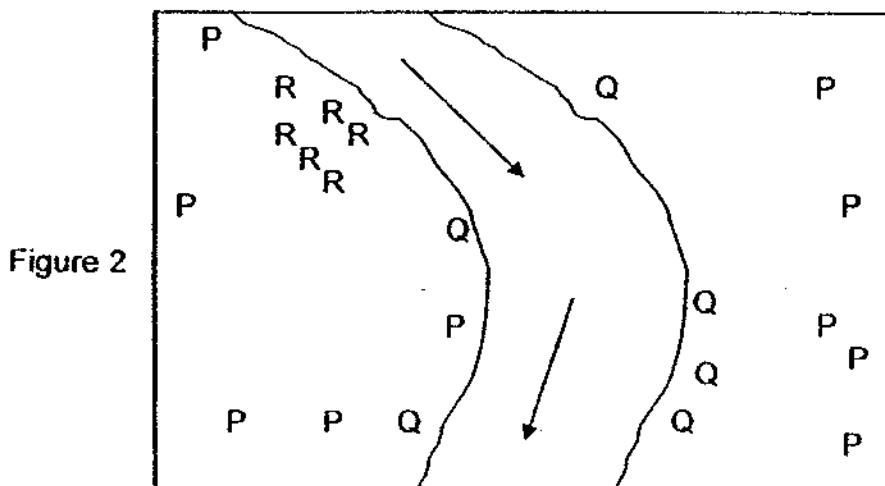
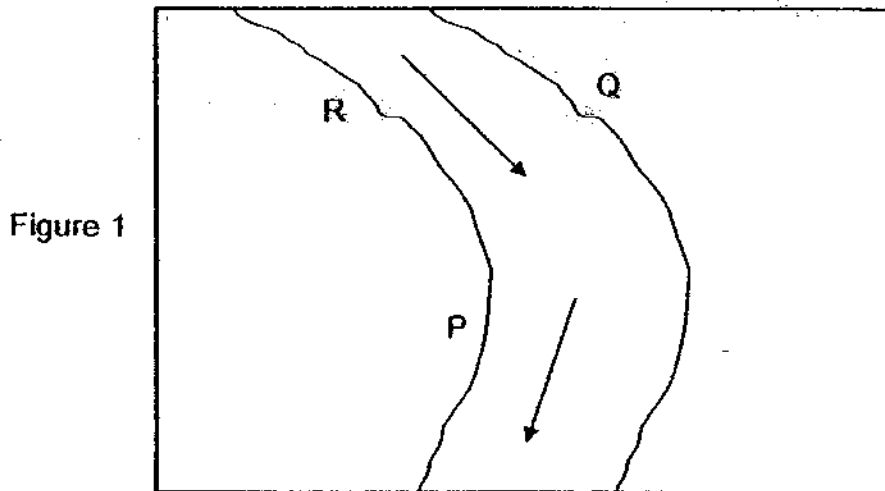

Based on what is observed in figure 2, what are the likely characteristics of the fruits of plants P, Q and R, which helped them to disperse their seeds?

	Plant P	Plant Q	Plant R
(1)	Fleshy and edible	Air spaces	Hooks-like structure
(2)	Dry and hard	Small and light	Fibrous husk
(3)	Waterproof covering	Dry pod	Wing-like structure
(4)	Hairy and light	Fibrous husk	Splits open when dry

25. The diagram below shows the water cycle.

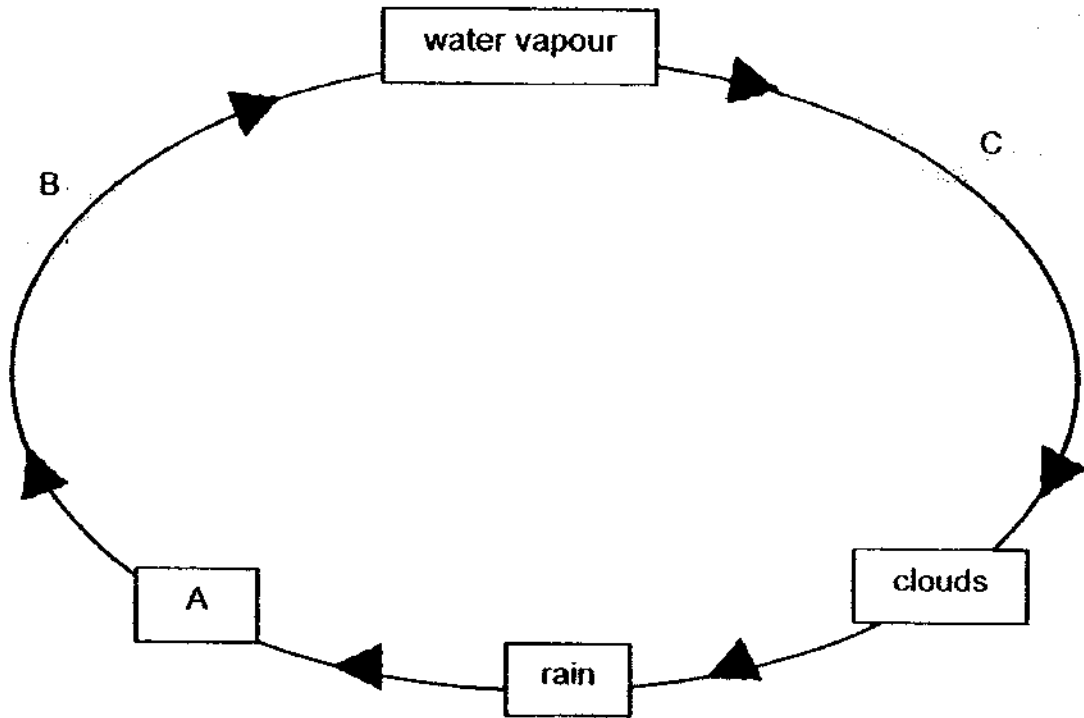

Which of the following best represents A, B and C?

	A	B	C
(1)	evaporation	river	condensation
(2)	condensation	river	Evaporation
(3)	river	evaporation	condensation
(4)	river	condensation	evaporation

26. Mona prepared two cups of water and then covered them. Look carefully at the results she obtained after two minutes.

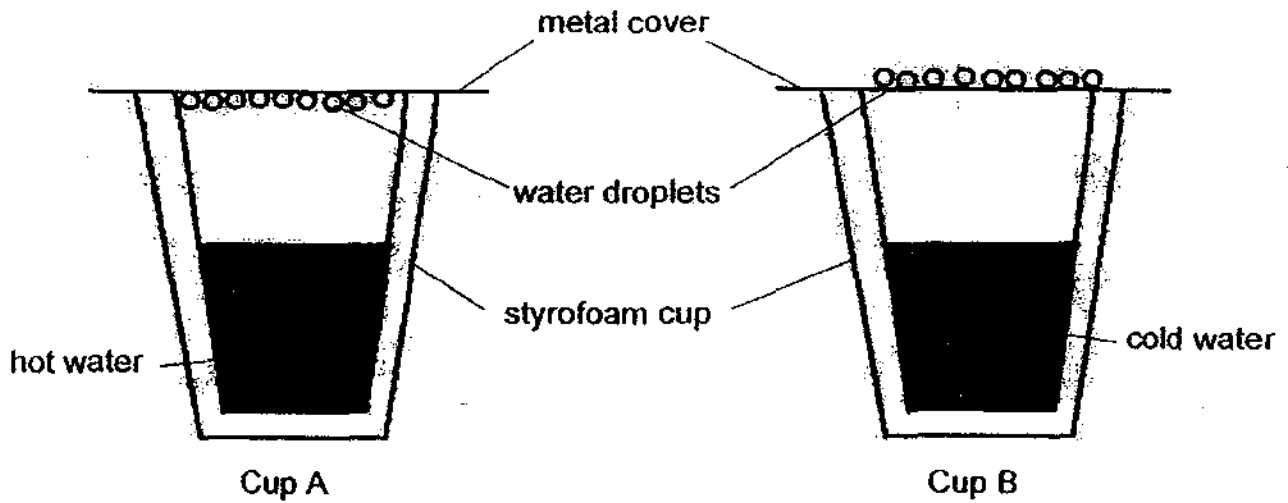

Which of the following statements are the results of the above experiment?

- A Styrofoam cups reduce heat gain or loss in the water.
 - B Hot water vapour in Cup A condensed on the hotter metal cover.
 - C Water vapour in the surrounding air condensed on the cool metal cover of Cup B.
 - D Water vapour inside Cup B does not condense on the cover as it is cooler than the cover.
- (1) B and C only
 - (2) C and D only
 - (3) A, C and D only
 - (4) B, C and D only

27. Three identical T-shirts E, F and G each containing the same amount of water were allowed to dry under different conditions as shown below. The humidity for that day was high.

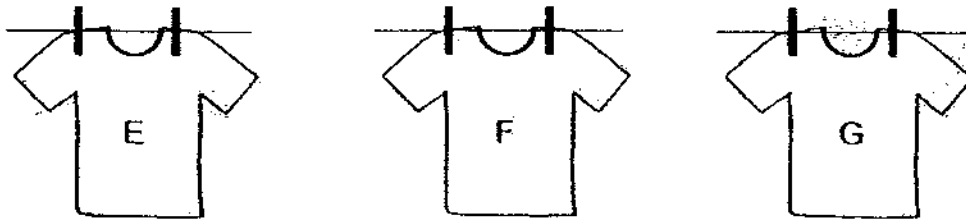

Daniel recorded the mass of each T-shirt at the start of the experiment and again after an hour. The results are shown below.

T-shirt	Mass of T-shirt at start of experiment / g	Mass of T-shirt after 1 hour / g
E	800	240
F	800	550
G	800	750

Based on the results, what is / are the possible explanation/s for the T-shirt which showed the greatest loss in mass?

- A The T-shirt was hung in a sunny place.
- B The T-shirt was made of a thinner material.
- C The T-shirt was hung out under windy conditions.
- D The T-shirt had the greatest exposed surface area.

- (1) A and C only
- (2) B and D only
- (3) A, B and C only
- (4) B, C and D only

28. Mary had three rods P, Q and R. She put them in positions A, B and C in the circuit below.

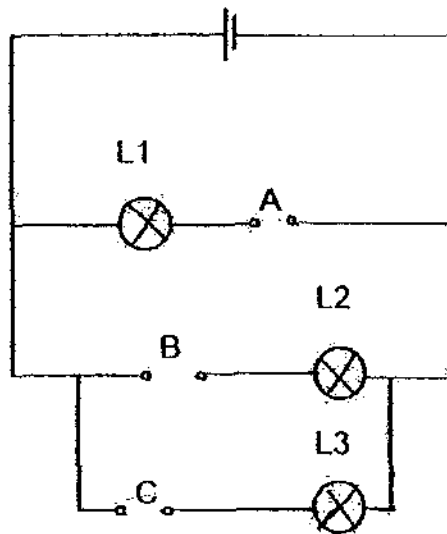

The results of the experiment are shown in the table below.

Position	A	B	C
Rod	P	Q	R
Lamp	L1	L2	L3
Does bulb light up?	Yes	No	No

She repeated the experiment by placing the rods at different positions as shown in the table.

Position	A	B	C
Rod	R	Q	P

Which one of the following shows the correct result?

	Lamp		
	L1	L2	L3
(1)	Yes	Yes	No
(2)	No	Yes	Yes
(3)	No	No	Yes
(4)	Yes	No	No

29. Some paper clips on a circuit card are connected to one another by some wires. Raymond wanted to find out which paper clips are connected. He used a circuit tester and attached it to two paper clips at a time. He recorded his findings in the table below.

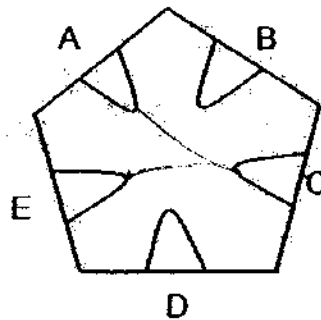

Clips connected	Does the bulb light up?
A and B	No
B and C	No
C and E	Yes
D and E	No
A and C	Yes
A and D	No
A and E	Yes

Which paper clips are connected to one another?

- (1) A and E only
 - (2) C and E only
 - (3) A, C and E only
 - (4) C, D and E only
30. Study the circuit below. Inside each box is the item labelled.

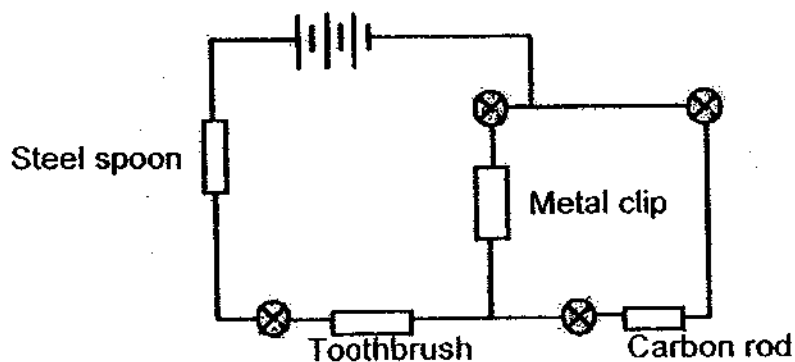

How many bulbs will light up?

- (1) 0
- (2) 1
- (3) 2
- (4) 3

∞ End of Section A ∞

Section B : Open-Ended Questions (40 marks)

Read the following questions carefully and write your answers in the space provided. The maximum marks that can be awarded are shown at the end of each question or part-question.

31. Mary ate a plate of fried rice for dinner. The graph shows how the amount of undigested food in the different parts of her digestive system.

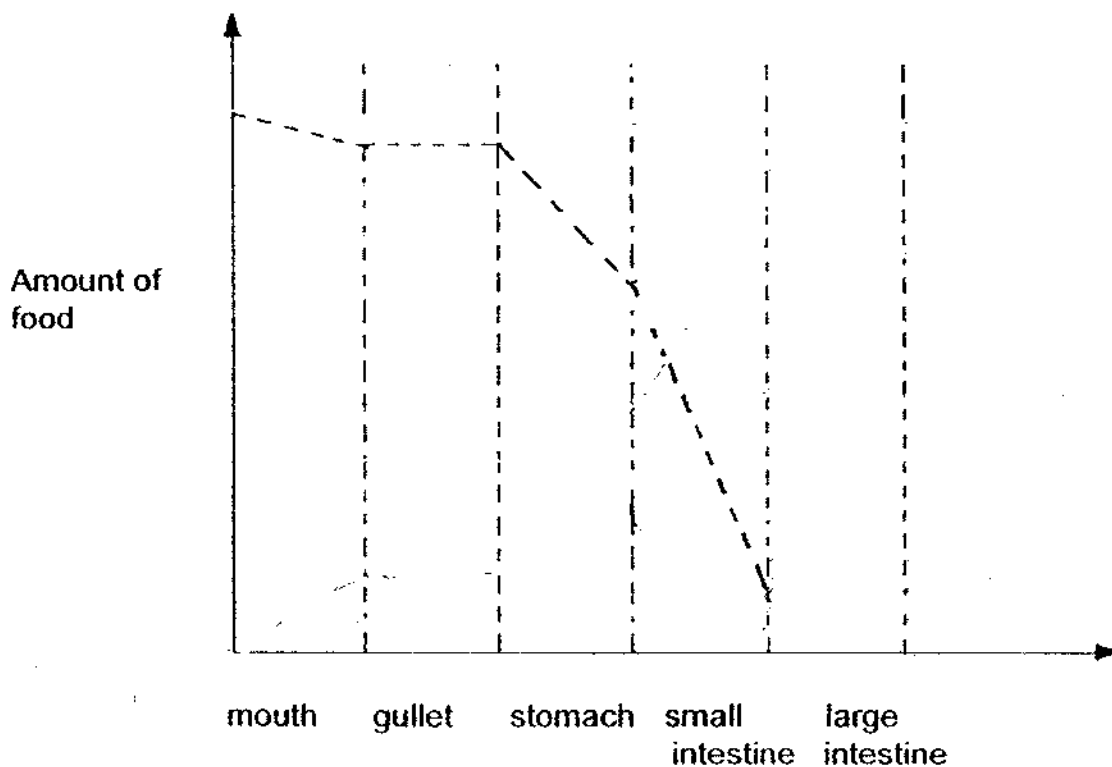

Key	
-----	undigested food
—————	digested food

- (a) Based on the graph, where in the digestive system would the greatest amount of food be digested? [1]

- (b) Complete the graph above to show what happens to the amount of undigested food in the large intestine. [1]

- (c) Use ———, draw the graph showing digested food from the mouth to the small intestine of the digestive system. [1]

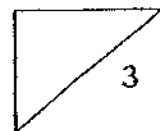



**CATHOLIC HIGH SCHOOL
PRIMARY 5
SEMESTRAL EXAMINATION 2
2009**

SCIENCE

Name: _____ (

Class : Primary 5 _____

Date : 29 October 2009

BOOKLET B

14 Questions
40 Marks

Total Time for Booklets A & B: 1 hour 45 minutes

Instructions to Candidates

Follow all instructions carefully.
Answer all questions.

Parent's Signature: _____

Date: _____

Score	
Section A	60
Section B	40
Total	100

32. Look at the flow chart.

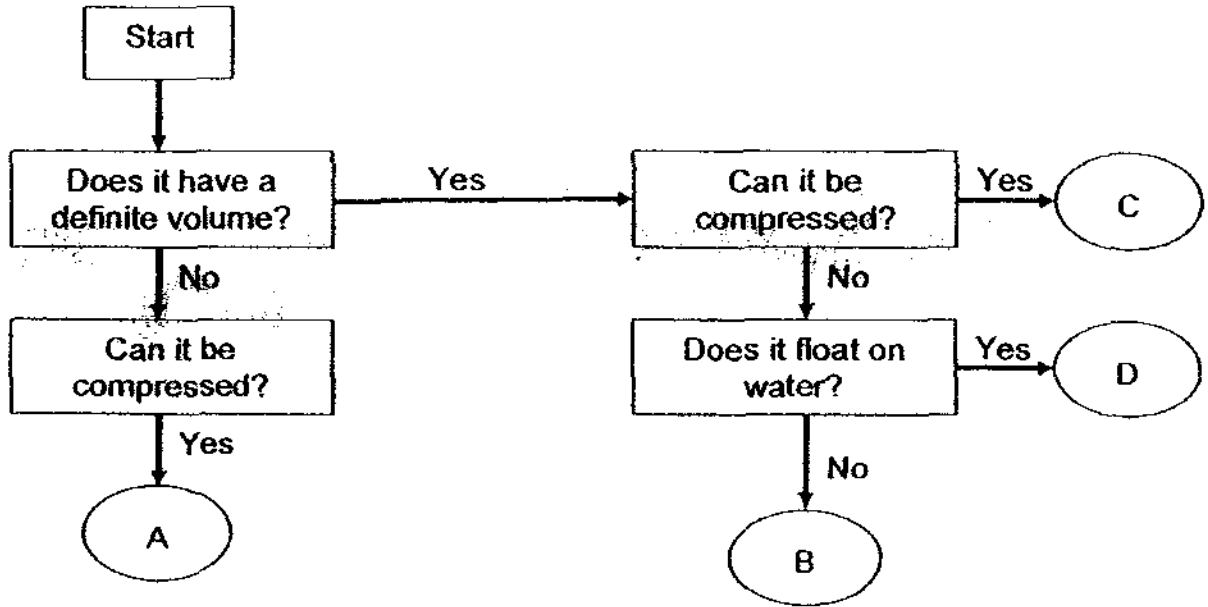

Match A, B, C and D in the chart to the examples in the table below.

[2]

Sponge	Plastic	Nitrogen	Mercury

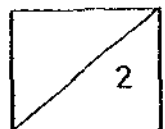

33. Joe shone a torch at a solid object from 3 different directions A, B and C as shown below.

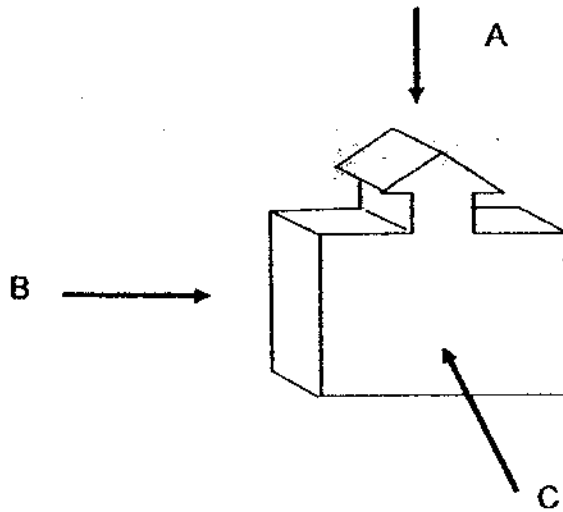

- (a) Draw the shadows Joe saw from directions A, B and C in the table below.

[1½]

Direction the torch was shining from	Shadow Joe saw
A	
B	
C	

- (b) What is the property of light that enables the shadows to be formed?

[½]

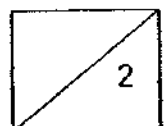

112

34. Jasper carried out an experiment to test 3 wires of different materials, A, B and C using the set-up below. The wires were of the same diameter and thickness.

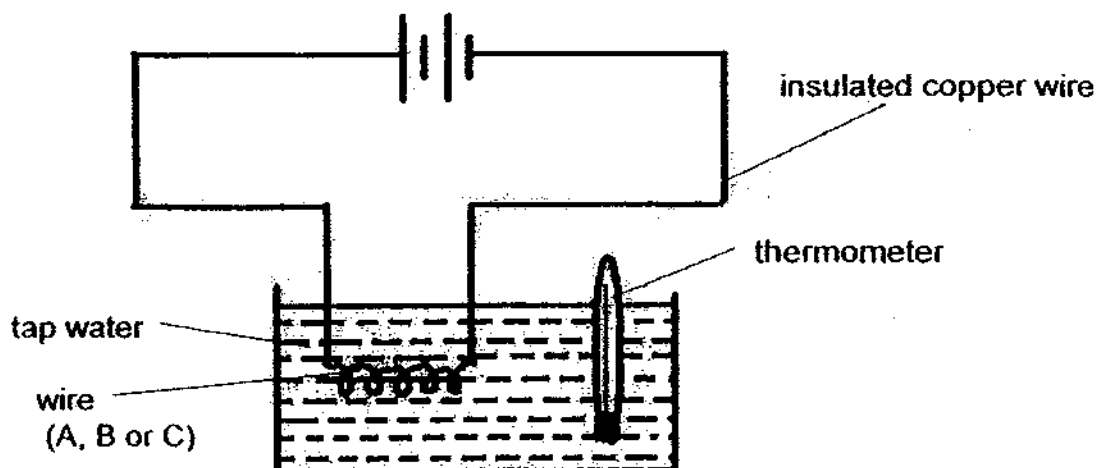

One wire was connected to the circuit and the temperature of the water was measured regularly. The experiment was then carried out for the other two wires, using the same set-up. New batteries and fresh tap water were used each time.

The table below shows the results Jasper obtained.

Time / min	Water Temperature / °C		
	Wire A	Wire B	Wire C
0	26	26	26
5	37	30	26
10	45	35	26
15	54	39	26
20	63	44	26
25	74	49	26
30	85	55	26

- (a) What is the aim of the experiment? [1]

- (b) Name the variable that he must keep constant in order to have a fair test. [1]

- (c) What can he conclude from the experiment? [1]

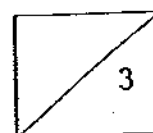

35. Jonathan investigated the effects of carbon dioxide on the organisms living in a pond over a period of time. He recorded his observations in the table below.

Carbon dioxide concentration / mg per litre	Population size			
	Organism A	Organism B	Organism C	Organism D
1	110	95	205	80
5	55	70	250	52
10	23	48	270	20
15	10	30	285	8

- (a) Which of the following could Organism C be? Circle your answer. [1]

Herbivorous

~~Omnivorous~~
animals

Carnivorous
animals

Omnivorous
animals

Water
plants

- (b) Using the information above, state how the carbon dioxide concentration affected the population size of each organism. [1]

- (c) Which organism was most affected by the increase in carbon dioxide in the pond? Explain using the data from the table. [1]

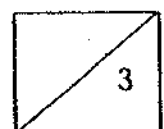

36. The following experiment was carried out to investigate the process of photosynthesis. A piece of cork was split into two and the green leaf sandwiched in between. The set-up was left for 8 hours.

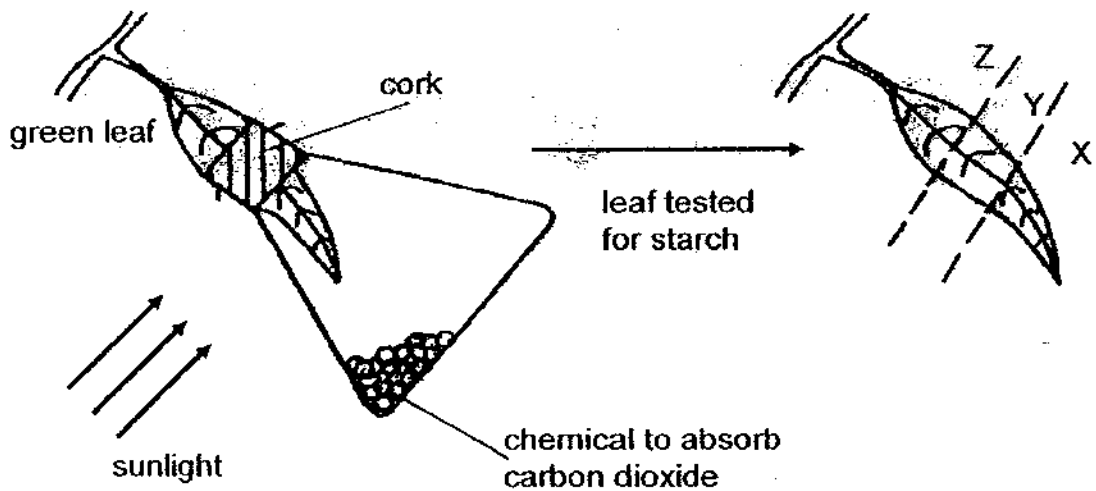

The leaf was tested for starch using iodine solution at the end of eight hours.

- (a) Indicate the colours of regions X, Y and Z in the table below after the starch test. [1]

Region	Colour
X	
Y	
Z	

- (b) Explain why regions X, Y and Z have the colours indicated in the table above. [1]

- (c) The experiment was repeated using another leaf which was completely covered with a layer of oil. What do you think will be observed after 3 days? Give a possible reason for the observation. [1]

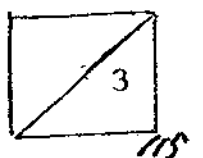

37. Mr Tay starts exercising slowly on a treadmill at first and gradually increases his speed.

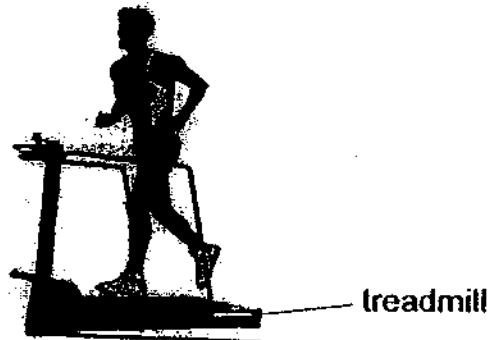

- (a) Mr Tay knows that his heartbeat increases after exercising on the treadmill. Using a stopwatch, what steps should he take to find out the change in his heartbeat? [2]

- (b) Why does Mr Tay's heartbeat increases when he is exercising on the treadmill? [1]

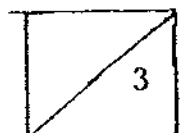

38. White flowers were placed in four containers of different coloured water, blue, red, brown and purple, as shown below.

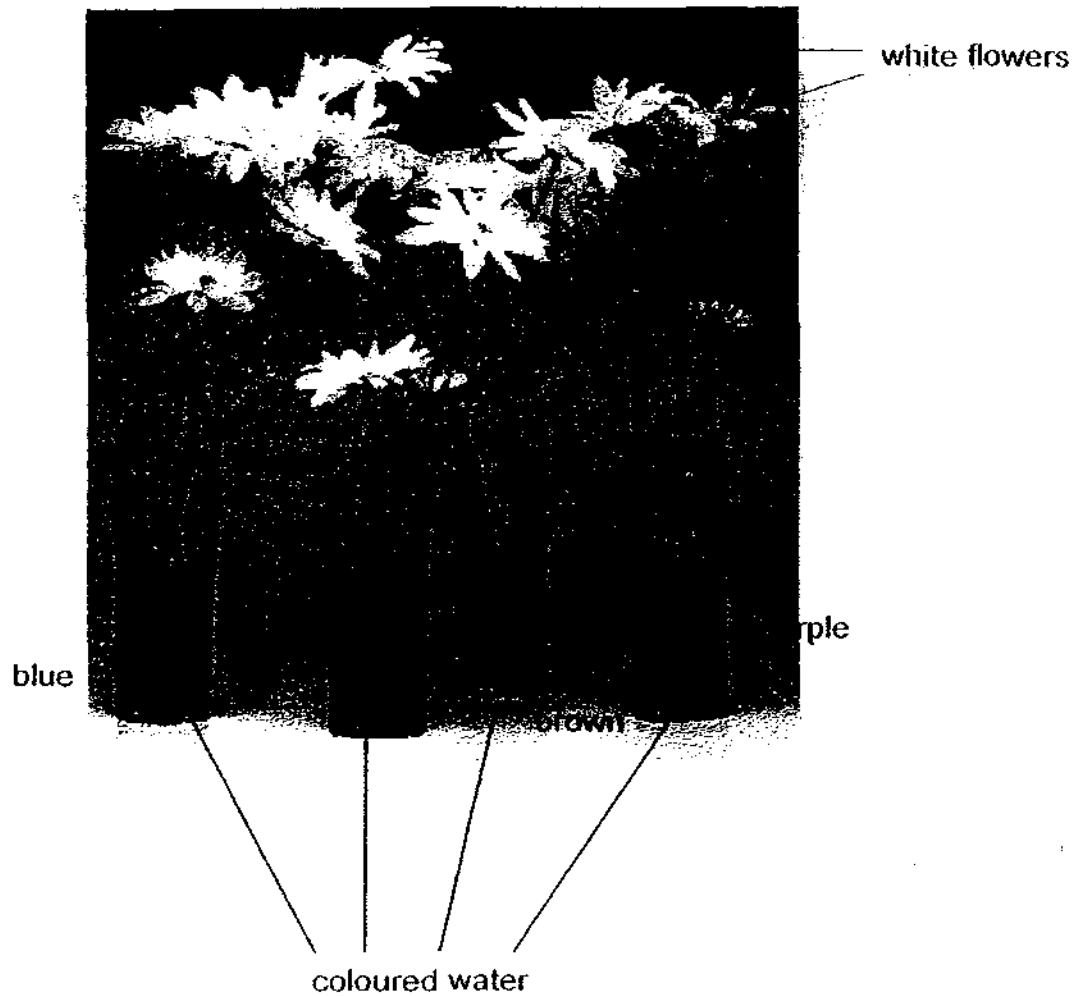

- (a) What would happen to the flowers after three days? [1]

- (b) Explain your answer in part (a). [1]

- (c) Is the above experiment able to conclude that plants have tubes that help it to survive? [1]

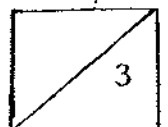

117

39. The diagram below shows a group of living things in a fish tank.

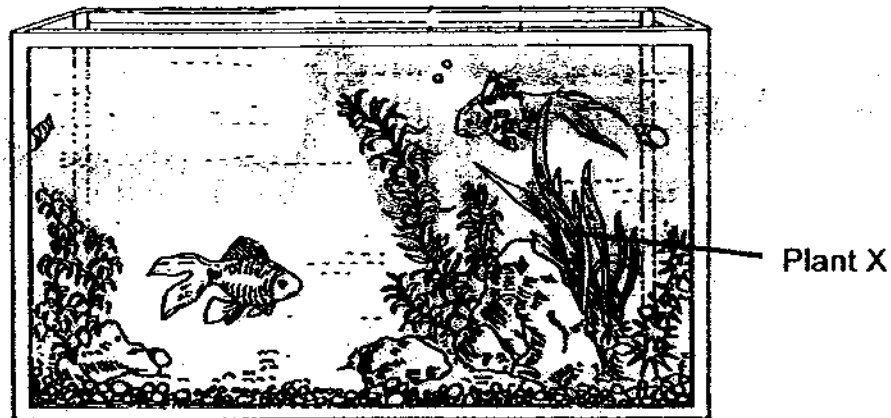

(a) Where does Plant X get most of its carbon dioxide for photosynthesis? [1]

(b) Alvin went away for one week. He was worried that the aquatic plants and fishes in his fish tank might die by the time he returns. Do you think his worry is necessary? Explain your choice of answer. [1]

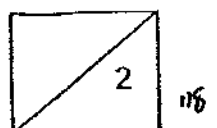

40. The drawing below shows the male reproductive organs of human beings.

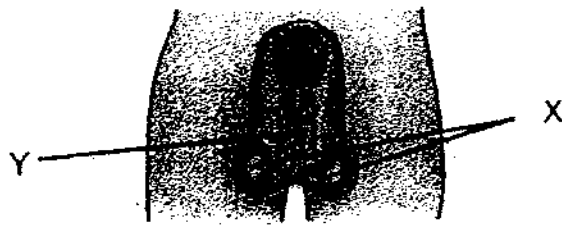

(a) Name the parts X and Y. [1]

Part X _____

Part Y _____

(b) What is the function of part X? [1]

Compare the male reproductive organs of a human being with that of a flower shown below.

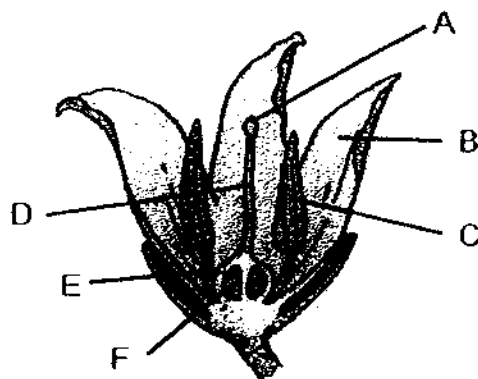

(c) Which part of the flower above has the same function as the part X of the male reproductive organs of human beings? [1]

(d) In what way is the sexual reproduction of both organisms similar? [1]

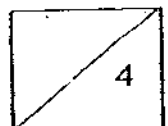

119

41. The diagram below shows the sequence of stages of growth of a soya bean seed.

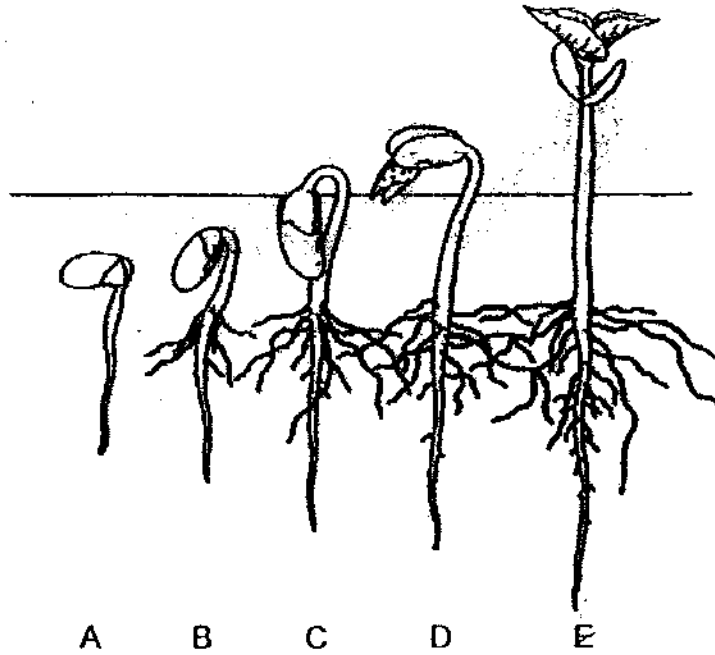

(a) Explain why at Stage E, the seedling does not depend on the seed leaves to grow? [1]

(b) Draw a line graph below showing the mass of the seed leaves as the seedling grows from Stage A to Stage E. [1]

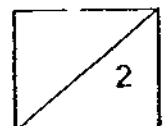
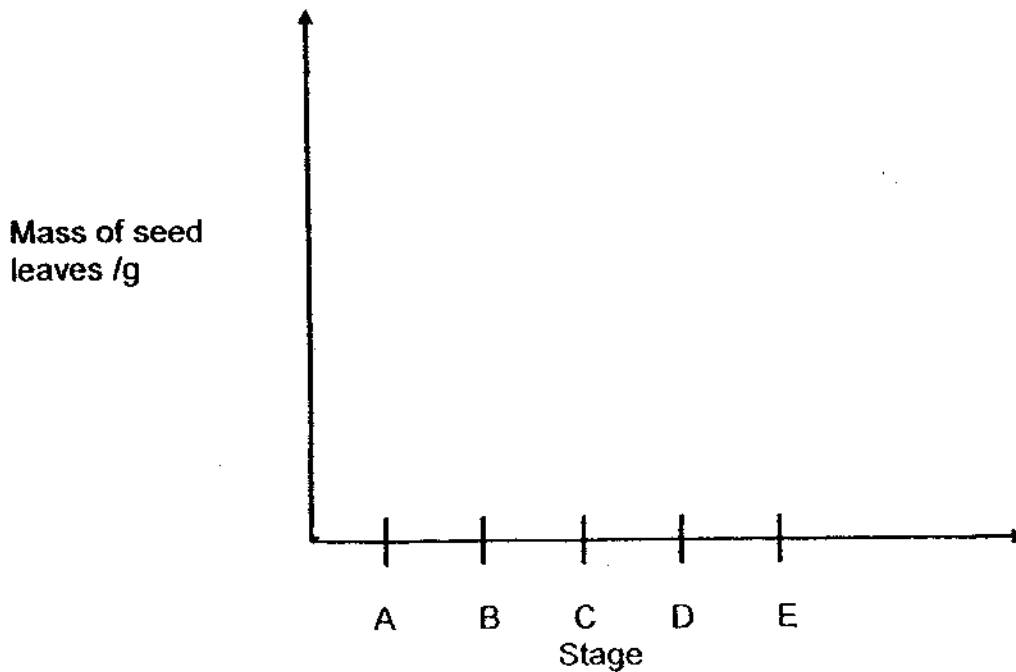

42. Paul was asked to demonstrate how rain is formed using the apparatus shown below.

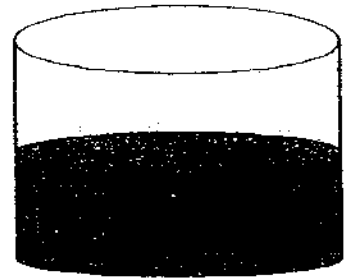
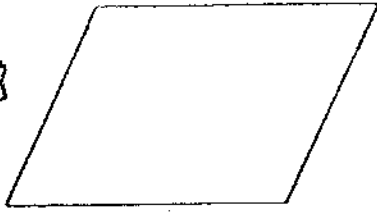

Ice cubes

Clear plastic sheet

Rubber bands

Beaker of hot water at 90°C

(a) - In the diagram below, draw and label what Paul observed inside the beaker after 20 minutes. [1]

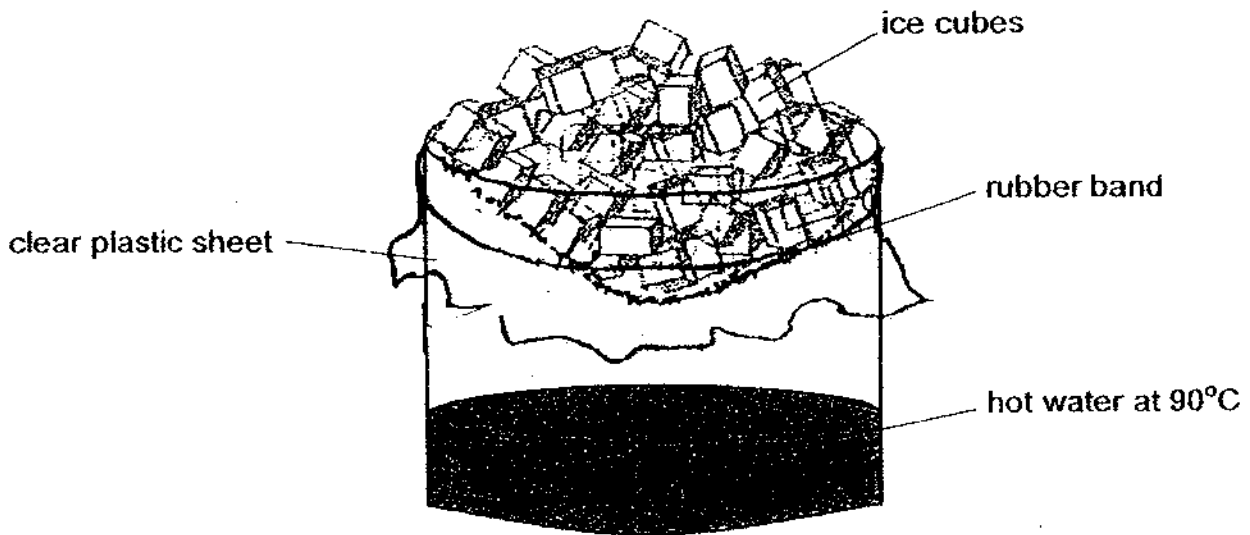

(b) Paul was able to slow down the process of rain-making by changing two variables.

State the changes made to two variables.

(i) _____ [1]

(ii) _____ [1]

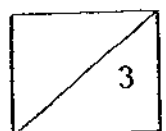

121

43. The game shown below was seen at the CH Family Day. A "rainbow" is found between two "mountains". To play, players move a loop from one end of the "rainbow" to the other end. The loop is connected to some batteries and the "trees" will light up each time the loop touches any part of the "rainbow".

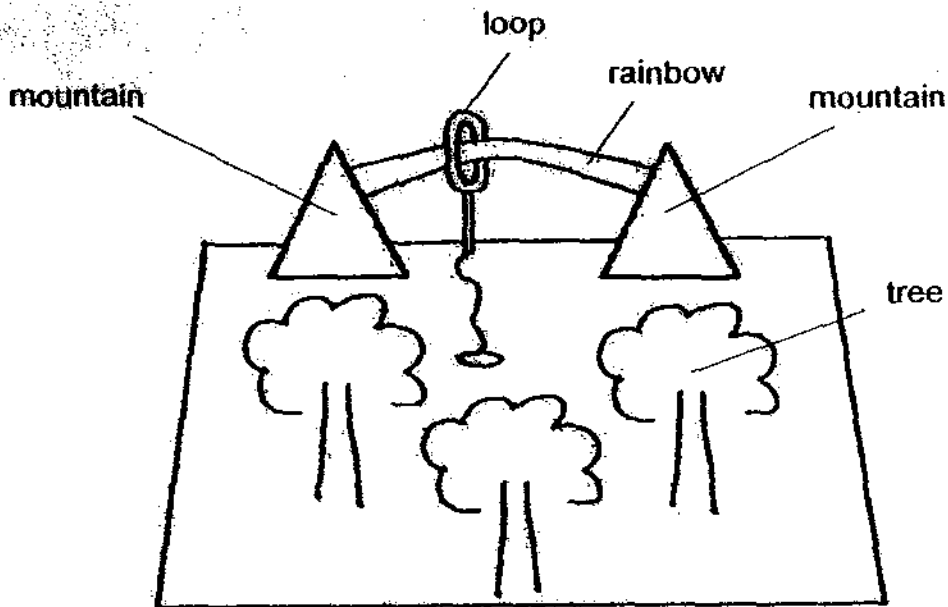

- (a) What is the "rainbow" made of? [1]

- (b) What causes the "trees" to light up? [1]

- (c) Explain how the game works. [2]

44. Daryl set up an electric circuit as shown in the diagram below. He made a 3-way switch using 4 pins P, Q, R and S. A clip was connected to Pin P and could be moved to touch pins Q, R and S.

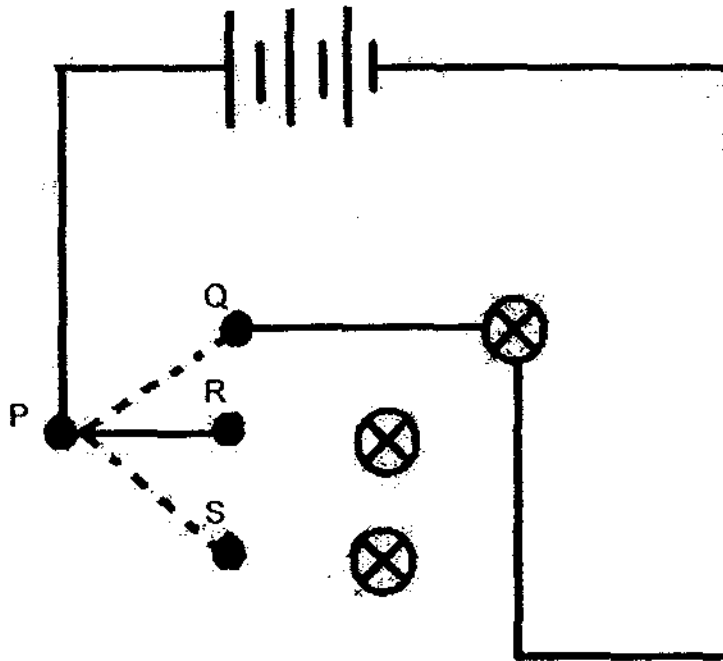

- (a) Draw 4 wires in the diagram to show how Daryl connected the 3-way switch to the bulbs so that he could move the clip to light up any one of the bulbs. [2]
- (b) What is the disadvantage of using the above system in a house? [1]

∞ End of Paper ∞

∞ Have you checked your answers? ∞

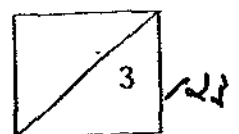

ANSWER SHEET

EXAM PAPER 2009

SCHOOL : CATHOLIC HIGH PRIMARY
SUBJECT : PRIMARY 5 SCIENCE

TERM : SA2

Q1	Q2	Q3	Q4	Q5	Q6	Q7	Q8	Q9	Q10	Q11	Q12	Q13	Q14	Q15	Q16	Q17
2	2	3	3	4	1	1	4	1	2	2	4	4	4	2	4	4

Q18	Q19	Q20	Q21	Q22	Q23	Q24	Q25	Q26	Q27	Q28	Q29	Q30
2	2	4	2	2	3	4	3	2	1	3	3	1

31)a) Small intestine.
 b)c)

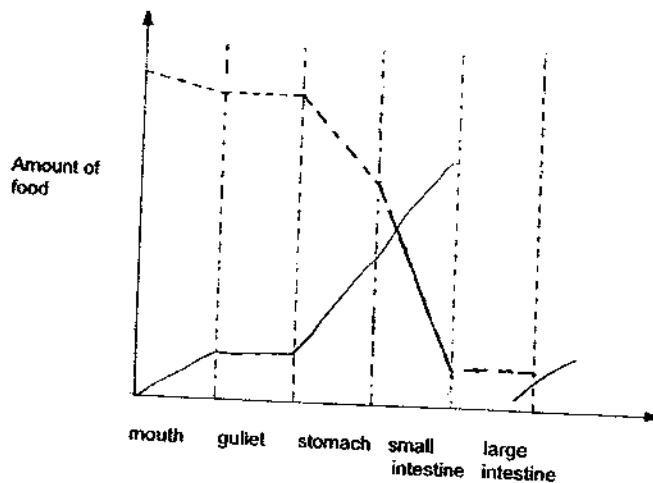

32) C, D, A, B

33)a)A:



B)



C)



b) Light travels in a straight line.

- 34)a)To find out which material is the best conductor of electricity.
 b)Length of wire.
 c)He can conclude that wire A is a better conductor of electricity than wire B.

- 35)a)Water plants.
 b)As the amount of carbon dioxide increases, the population of A, B and D decreases while the population of C increases.
 c)The population of A decreased the most.

- 36)a)X: Brown Y: Brown Z: Dark-blue
 b)There is a chemical to absorb carbon dioxide from X, and the cork is preventing Y to absorb light energy, while Z is not block so it can photosynthesise.
 c)The leaf will die. Gaseous exchange cannot take place.

- 37)a)Time the heart beat for 1 minute before and after exercising.
 b)The heart needs to pump more blood rich in oxygen to all parts of the body, burning fats to produce energy.

- 38)a)The colour of the flowers would go accordingly to the colouring in the container.
 b)The roots take in the coloured water and the xylem transports it to the flower.
 c)No. The experiment must also show that plants that phloem tubes carry food.

- 39)a)From the fishes.
 b)No. The fishes will give out carbon dioxide for the water plants to absorb and photosynthesize in the presence of light and produce oxygen for the fishes and food for itself while the water plants also acts as a food source for the fishes.

- 40)a)X: testes Y: penis
 b)It produces sperms that would fuse with the egg during fertilization.
 c)C.
 d)They both need a male and a female for fertilization.

- 41)a)It has leaves that contain chlorophyll which traps light energy to make food.

b)

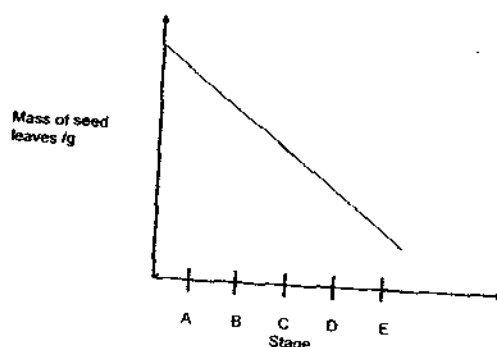

42)a)

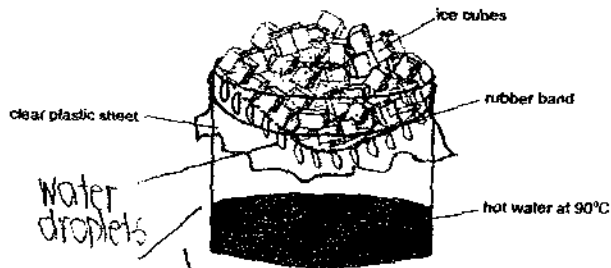

- b)i) Change the hot water to cold water.
- ii) Reduce the number of ice.

43)a) Metal.

- b) Electricity flowing through the bulbs in the trees caused them to light up.
- c) The game is like a circuit and the loop touches the rainbow which is made of metal, a closed-circuit is formed, allowing current to flow through the bulbs in the mountain and hence, lights up the bulbs.

44)a)

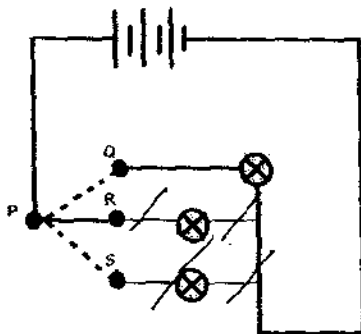

b) We can use only one appliances in the house.