



**NAN HUA PRIMARY SCHOOL
SEMESTRAL ASSESSMENT 2 – 2009
PRIMARY 5**

SCIENCE

BOOKLET A

30 Multiple Choice Questions (60 marks)

Total Time for Booklets A and B : 1 hour 45 minutes

INSTRUCTIONS TO CANDIDATES

1. Write your name and index number in the space provided.
2. Do not turn over the page until you are told to do so.
3. Follow all instructions carefully.
4. Answer all questions.
5. Shade your answers in the Optical Answer Sheet (OAS) provided.

Marks Obtained

Booklet A		/ 60
Booklet B		/ 40
Total		/100

Name: _____ () **Class:** P5 _____

Date : 29 October 2009

Parent's Signature: _____

Section A: (30 x 2marks = 60marks)

For each question from 1 to 30, four options are given. One of them is the correct answer. Make your choice (1, 2, 3 or 4). Shade the correct oval (1, 2, 3 or 4) on the Optical Answer Sheet.

1. The water cycle takes place continuously because _____.
- (1) the mass of water changes constantly
 - (2) water occupies a constant amount of space
 - (3) water has no fixed shape and so constantly changes its shape
 - (4) the sun provides a constant source of energy for water to evaporate
2. The following statements describe the different activities that occur in the sexual reproduction of a flowering plant.
- A: Fertilisation takes place.
B: A fruit containing seeds develops.
C: Pollen grains land on the stigma.
D: Pollen tubes grow towards the ovules.
E: Pollen grains are released by the anther.
- Which one of the following shows the correct sequence in the process of sexual reproduction in a flowering plant?
- (1) A → B → C → D → E
 - (2) E → C → D → A → B
 - (3) B → C → E → D → A
 - (4) C → E → D → A → B
3. Many animals lay eggs. They lay eggs to _____.
- (1) provide shelter for themselves
 - (2) protect themselves from predators
 - (3) provide sufficient food for their young
 - (4) ensure the continuity of their own kind



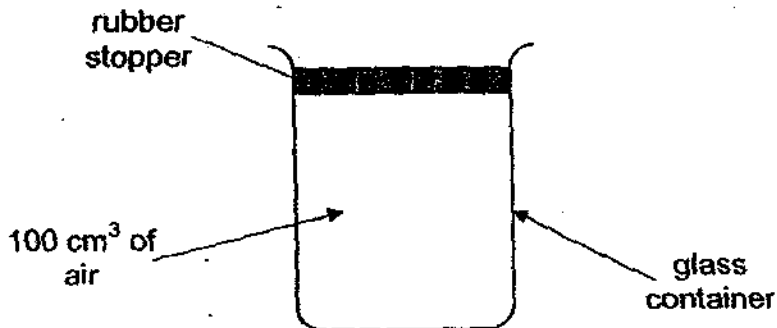





4. Nancy prepared a glass container which contained 100 cm^3 of air (taken from the surroundings) as shown in the set-up shown below.

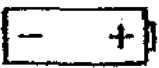

What is the approximate volume of oxygen present in the container?

- (1) 1 cm^3
 - (2) 21 cm^3
 - (3) 78 cm^3
 - (4) 100 cm^3
5. Which one of the following describes the function of the chloroplasts in plant cells?
- A: It gives cells their regular shapes.
 - B: It allows the plant to grow quickly.
 - C: It contains green pigment that makes the leaf green.
 - D: It contains chlorophyll which enables the plant to photosynthesize.
- (1) A and B only
 - (2) A and D only
 - (3) C and D only
 - (4) A, B, C and D

6. Which one of the following electrical components does not match the symbol?

	Electrical Component	Symbol
(1)		
(2)		
(3)		
(4)		

7. The diagram below shows a circuit tester.

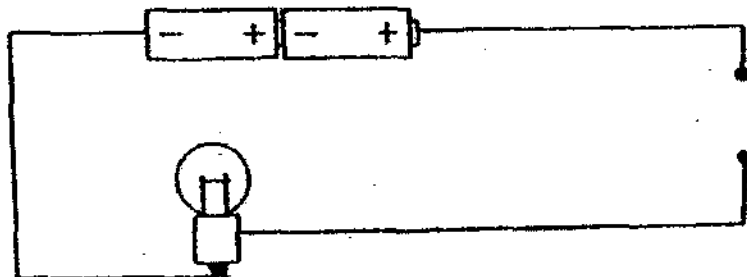

Which one of the following items will cause an open circuit when placed in the gap?

- (1) Eraser
- (2) Iron pin
- (3) Silver ring
- (4) Gold necklace

8. Which one of the following plants does not go through the life cycle shown below?

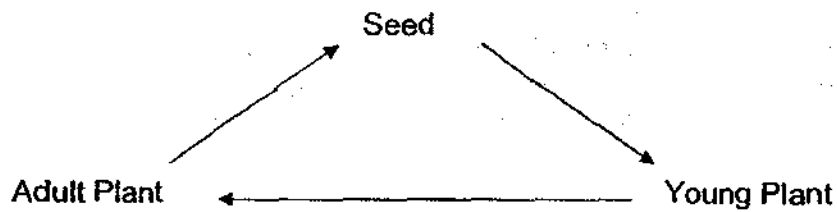

- (1) Mango
- (2) Rambutan
- (3) Bird's Nest Fern
- (4) Long Bean Plant

9. The classification table below shows how matter can be grouped.

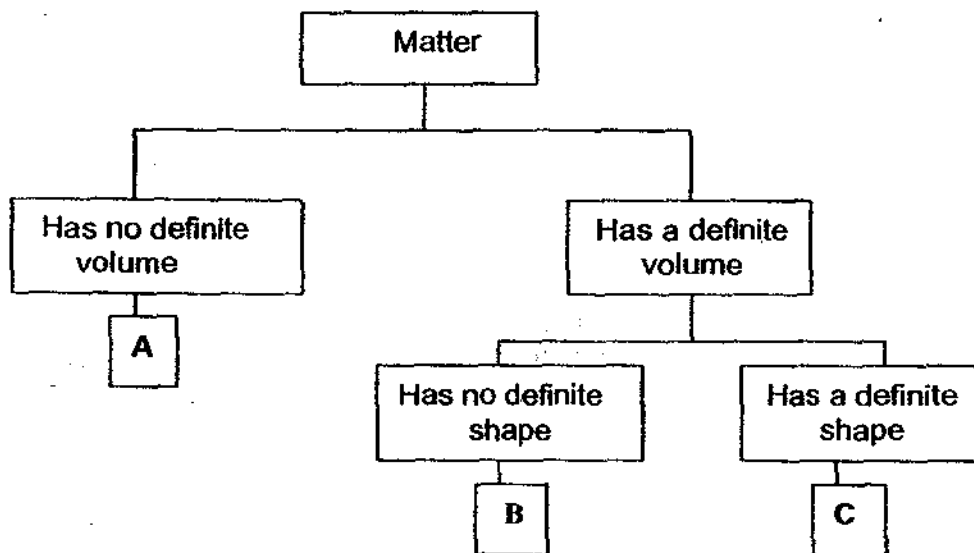

Which one of the following best represents A, B and C at room temperature respectively?

	A	B	C
(1)	oil	stone	oxygen
(2)	water vapour	milk	brown sugar
(3)	carbon dioxide	red bean	salt
(4)	pen	cough syrup	nitrogen

10. What is the function of the large intestine in our digestive system?

- (1) It digests food.
- (2) It passes the digested food to the blood.
- (3) It passes the undigested food out of the body.
- (4) It absorbs water from the undigested food.

11. The bar graph below shows how water is used in various activities in Mr Lee's household.

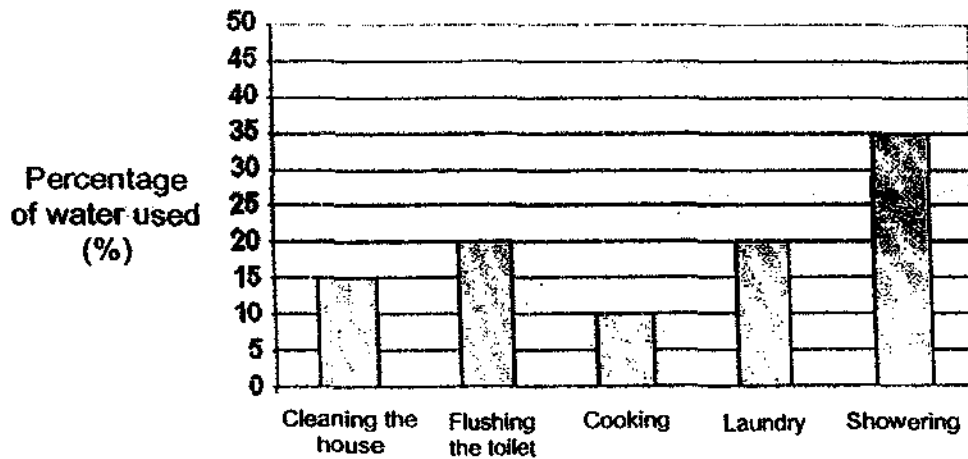

What information can be obtained from the graph?

- A: How water is used in Mr Lee's household.
- B: The activity that uses the most water in Mr Lee's household.
- C: The different ways Mr Lee's family can conserve water at home.
- D: The percentage of water used in the different activities in Mr Lee's household.

- (1) B and C only
- (2) A, B and C only
- (3) A, B and D only
- (4) A, C and D only

12. Which of the following statements about the umbilical cord is / are true?

- A: It is the passageway through which the baby will be born.
- B: It transfers oxygen and food from the mother to the developing foetus.
- C: It transfers carbon dioxide and other wastes from the developing foetus to the mother.

- (1) A and B only
- (2) A and C only
- (3) B and C only
- (4) A, B and C

13. Study the concept map below.

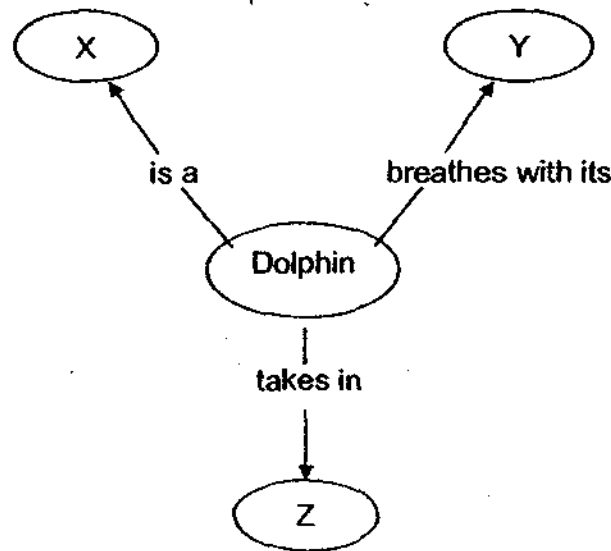

Which of the following best represent X, Y and Z respectively?

	X	Y	Z
(1)	Mammal	Lungs	Dissolved air
(2)	Mammal	Lungs	Atmospheric air
(3)	Fish	Gills	Dissolved air
(4)	Fish	Gills	Atmospheric air

14. Study the following graph below carefully. The graph shows the change in Fiona's heart rate over a few hours.

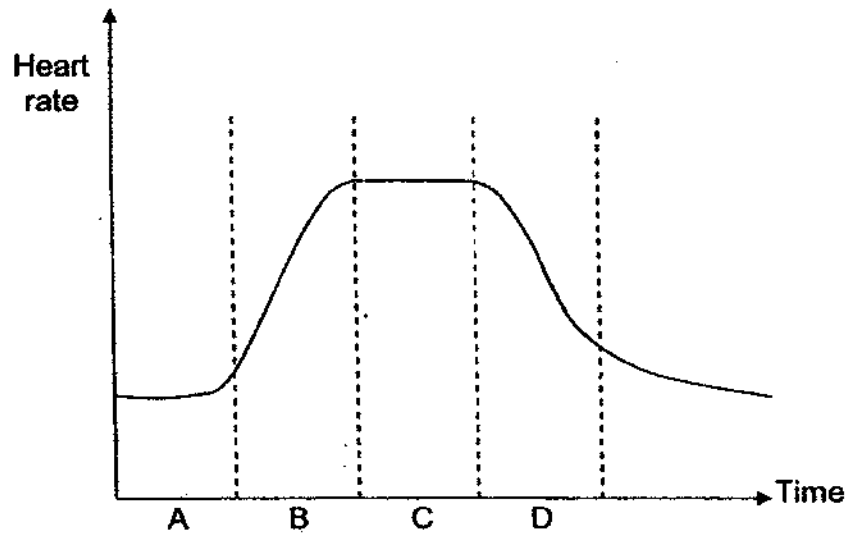

During which period is Fiona resting after a swim?

- (1) A only
- (2) D only
- (3) A and B only
- (4) C and D only

15. The chart below shows how three of our body systems work together to allow respiration to be carried out. Study the chart carefully.

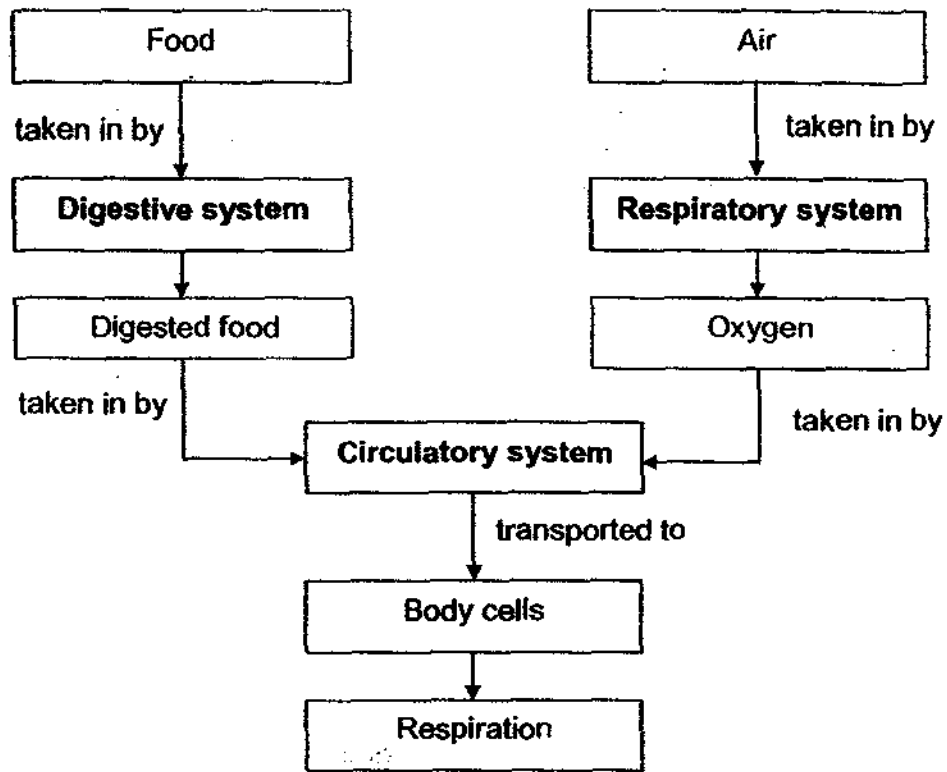

Based on the diagram above, which of the following is/are true?

- A: The circulatory system is essential for respiration to take place.
- B: The digestive system takes in oxygen and gives out carbon dioxide for respiration to take place.
- C: The circulatory system helps to transport the digested food and oxygen to body cells for respiration to take place.

- (1) A only
- (2) A and B only
- (3) A and C only
- (4) A, B and C only

16. Which of the following statements about the animal and plant transport systems are true?

- A: An animal needs an organ to pump blood to transport materials around the body
- B: No organs are needed by a plant to transport materials around the plant.
- C: A plant has only one type of tube to transport materials around the plant.
- D: Only oxygen and digested food are transported around the body of an animal.

- (1) A only
- (2) A and B only
- (3) A, B and D only
- (4) B, C and D only

17. Which of the statements is true of the function of blood?

- (1) It produces oxygen.
- (2) It helps to regulate our body temperature.
- (3) It makes sure that we are not dehydrated at all times.
- (4) It transports digested food, waste materials, oxygen and carbon dioxide to various parts of our body.

18. The diagram below shows the cross-section of a stem. Which part of the stem consists of special cells that transport food and water in the plant?

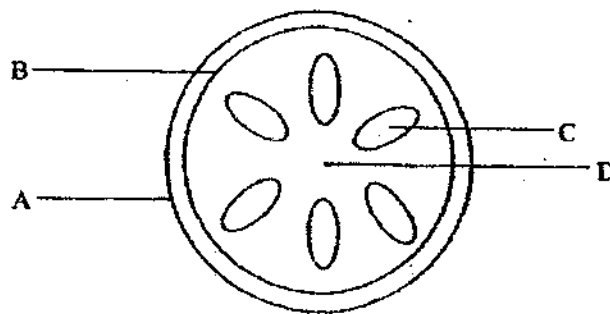

- (1) A
- (2) B
- (3) C
- (4) D

19. Our cells contain genes that carry our genetic information. These genes are found within the _____ of the cells.

- (1) nucleus
- (2) cytoplasm
- (3) chloroplasts
- (4) cell membrane

20. In order for Substance A to enter a plant cell and reach the nucleus, it has to pass through various parts of the plant cell. Which one of the following shows the correct order of parts Substance A has to pass through to reach the nucleus?

- (1) cell wall → cytoplasm → cell membrane
- (2) cell wall → cell membrane → cytoplasm
- (3) cell membrane → cell wall → cytoplasm
- (4) cell membrane → cytoplasm → cell wall

21. Study the circuit diagram below.

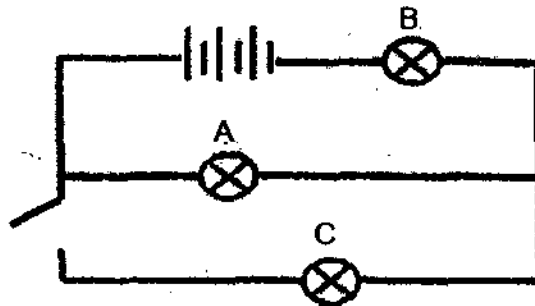

Which of the bulbs will remain lit when the circuit is opened as shown in the diagram above?

- (1) A only
- (2) C only
- (3) A and B only
- (4) B and C only

22. Peter conducted an experiment to find out the effect of increasing the number of batteries in series connection. He plotted his data into the graph as shown below.

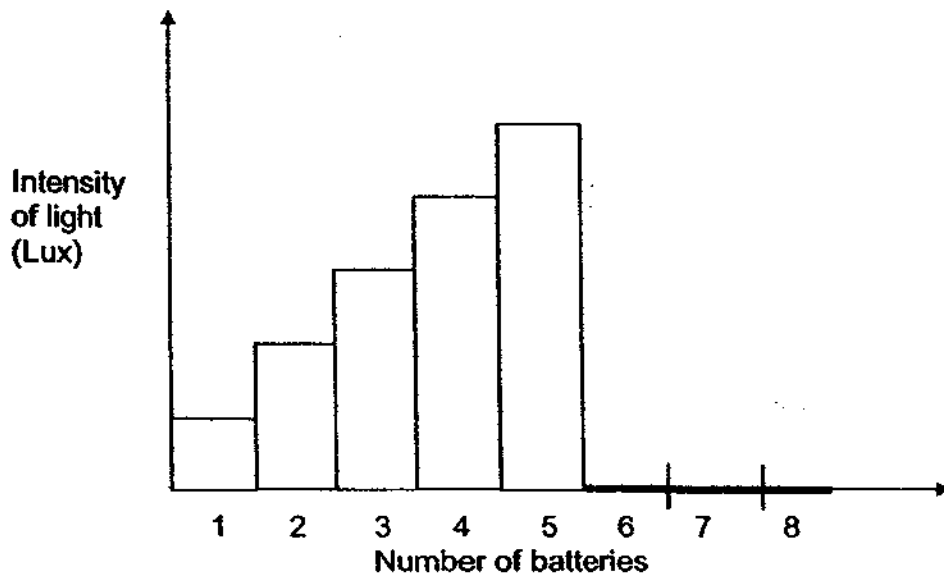
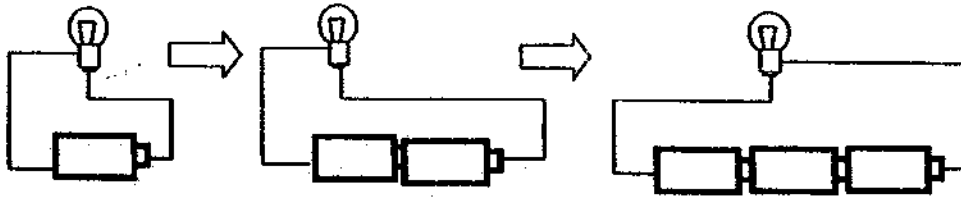

Which one of the following options is the most likely explanation for the result he has obtained?

- (1) The sixth battery was flat.
- (2) The bulb fused when 6 batteries were used.
- (3) The bulb was extremely dim when 6 or more batteries were used.
- (4) The bulb was extremely bright when 6 or more batteries were used.

23. Which one of the following electric circuits allows only 1 bulb to light up?

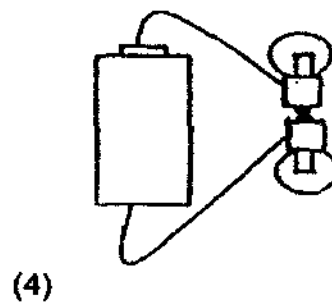
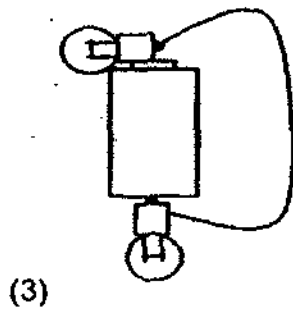
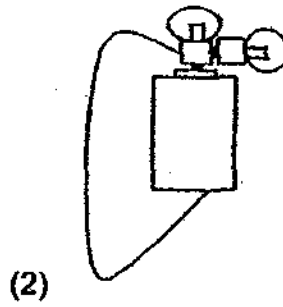
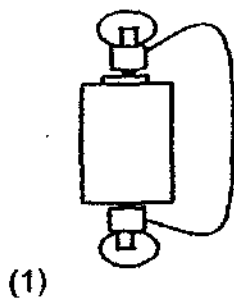

24. Study the diagram below.

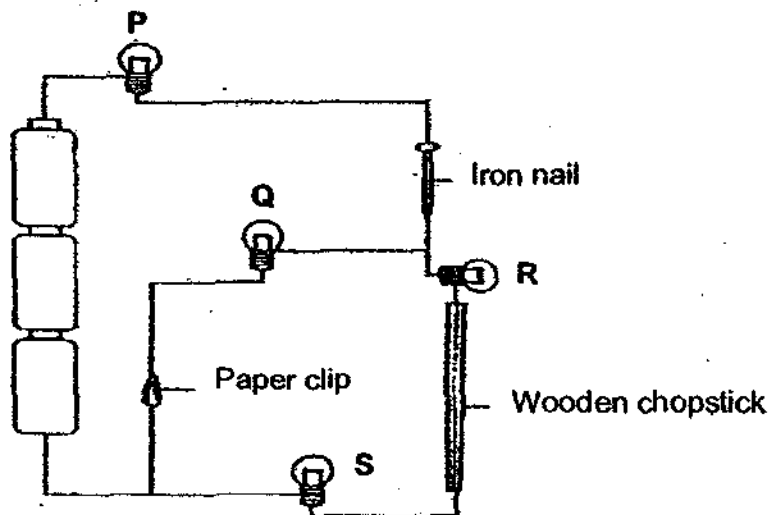

Which bulbs will not light up?

- (1) P and Q only
- (2) R and S only
- (3) Q, R and S only
- (4) P, R and S only

25. The diagram below shows parts of a bulb labelled A, B, C and D.

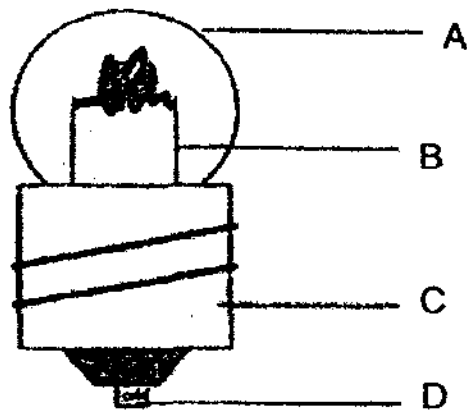

Which of the parts, A, B, C or D, are conductors of electricity?

- (1) B and C only
 - (2) C and D only
 - (3) A, B and C only
 - (4) B, C and D only
26. Which one of the following does not help to conserve electricity?
- (1) Use fans instead of air-conditioners.
 - (2) Use energy-saving lamps instead of normal light bulbs.
 - (3) Leave the lights on during the day to keep the room warm.
 - (4) Avoid leaving electrical appliances such as the television, computer and radio on stand-by mode.

27. The diagram shows the human skeleton.

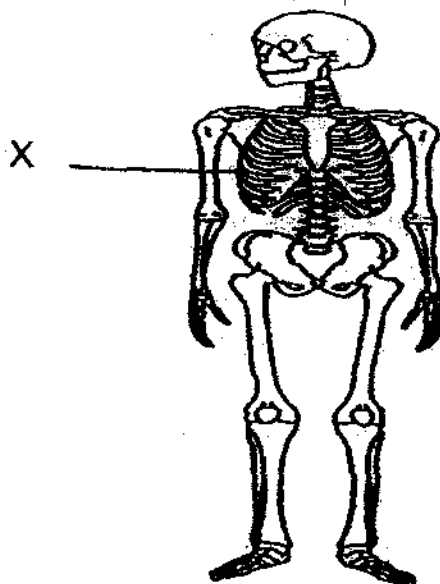

What does X protect?

- (1) Lungs and heart only.
 - (2) Lungs, heart and stomach only.
 - (3) Liver, kidney and stomach only.
 - (4) Liver, heart, kidney and stomach only.
28. Tom found 3 objects and wanted to test if they were magnets. He bought a magnet from the school bookshop and placed it next to each of the objects. This is what he observed.

Object	Observation
Object A	No reaction
Object B	Repelled
Object C	Attracted

Which of the following object(s) is **definitely** a magnet?

- (1) Object B
- (2) Object C
- (3) Objects A and C
- (4) Objects B and C

29. Alex conducted a study on Animal X and Animal Y. He used a checklist and placed a tick in the appropriate box when he made an observation. The completed checklist is as follows:

Observation	Animal X	Animal Y
Eggs are laid in water	√	√
There are 4 stages in the life cycle		
It has six legs		√

Which of the following could be Animals X and Y?

	Animal X	Animal Y
(1)	frog	mosquito
(2)	frog	dragonfly
(3)	mosquito	frog
(4)	dragonfly	frog

30. The diagram below shows a pump connected to a glass jar. The capacity of the jar is 500 cm^3 . The jar contains 50 cm^3 of water.

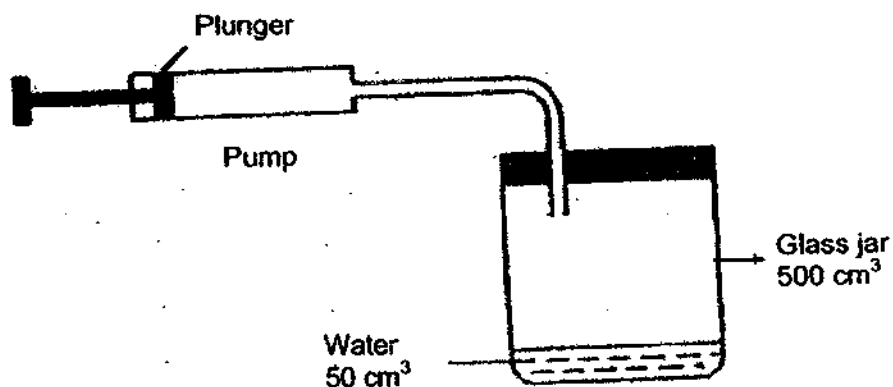

When the plunger is pushed in completely, 30 cm^3 of air is forced into the jar. What is the volume of air in the jar?

- (1) 30 cm^3
- (2) 450 cm^3
- (3) 480 cm^3
- (4) 500 cm^3



**NAN HUA PRIMARY SCHOOL
SEMESTRAL ASSESSMENT 2 – 2009
PRIMARY 5**

SCIENCE

BOOKLET B

14 Open-ended questions (40 marks)

Total Time for Booklets A and B : 1 hour 45 minutes

INSTRUCTIONS TO CANDIDATES

1. Write your name and index number in the space provided.
2. Do not turn over the page until you are told to do so.
3. Follow all instructions carefully.
4. Answer all questions.
5. Write your answers in this booklet.

Marks Obtained

Section B		/40
-----------	--	-----

Name: _____ () Class: P 5 _____

Date : 29 October 2009

Parent's Signature: _____

Section B: (40marks)

Write your answers to question 31 to 44.

The number of marks available is shown in brackets [] at the end of each question or part question.

31. Fill in the boxes with the correct processes responsible for the following observations. [2]

	Observation	Process
(a)	Ice turning to water	
(b)	Water turning to steam at 100 °C	
(c)	Wet clothes drying on a sunny day	
(d)	Glasses turning misty when we step out from an air-conditioned room	

32. The following are statements on reproduction of human beings. Some of the statements are true while others are false. Put a tick (✓) in the appropriate box. [2]

	Statement	True	False	Impossible to Tell
(a)	All young mammals develop from a fertilized egg.			
(b)	Jason has attached ear lobes as he had inherited the characteristic from his father.			
(c)	The genetic traits of a person come from the female reproductive cell only.			
(d)	A male reproduction cell must travel to fuse with a female reproduction cell in order for fertilization to take place.			

Score	4
-------	---

33. The diagram below shows part of the human respiratory system.

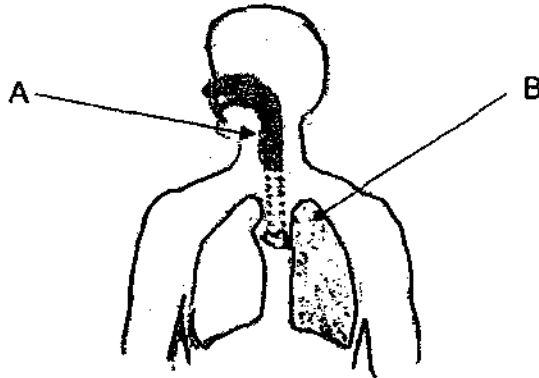

(a) Identify the parts A and B. [2]

A: _____

B: _____

(b) Why is the human respiratory system important to humans? [1]

34. John was given two cells, X and Y.

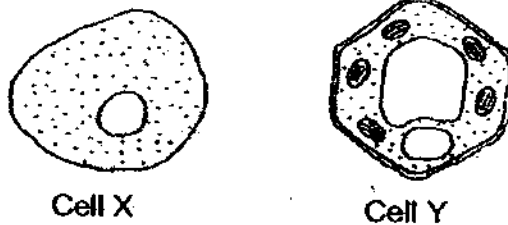

After examining the cells, he concluded that X is an animal cell while Y is a plant cell.

(a) Some parts of the plant cell are not found in the animal cell. Name one part. [1]

(b) John tested cell Y for the presence of starch using iodine solution. What has to be removed from the cell in order for the test to be successful? [1]

Score	5
-------	---

- 35 Tony had 3 different rods, V, W and Y. He placed 3 rods at each time in the electrical circuit shown below and recorded his observations of the 3 light bulbs, L1, L2 and L3, in the table below.

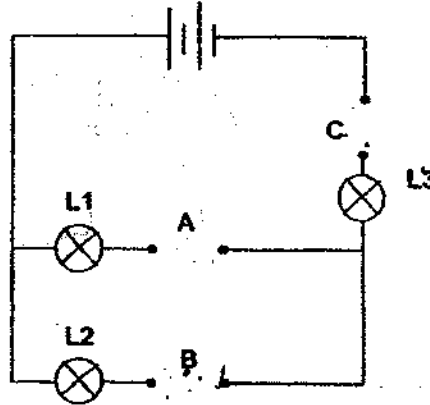

Rod placed at			Bulb Lighted Up		
A	B	C	L1	L2	L3
V	Y	W	No	No	No
V	W	Y	Yes	No	Yes

Based on the results above, which rod(s) is/are conductor(s) of electricity? [2]

36. The diagram below shows the stages in the life cycle of a butterfly.

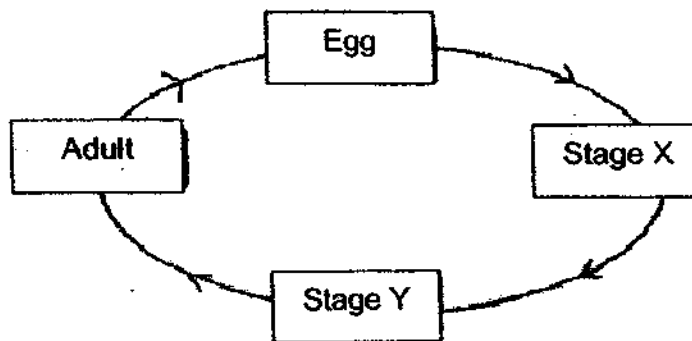

State 2 differences between Stage X and Stage Y in the life cycle of the butterfly. [2]

Score	4
-------	---

37. The graphic organiser below classifies the plants according to their method of dispersal.

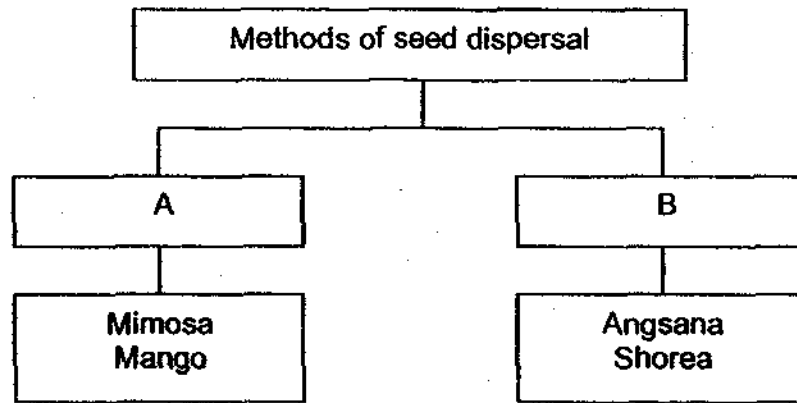

- (a) How are the plants classified? [2]

Group A: _____

Group B: _____

- (b) Name another fruit that can be classified under A and B respectively. [1]

A: _____

B: _____

- (c) Julia found an exotic fruit on a field trip. She drew it in her Nature Study Book and showed it to her teacher.

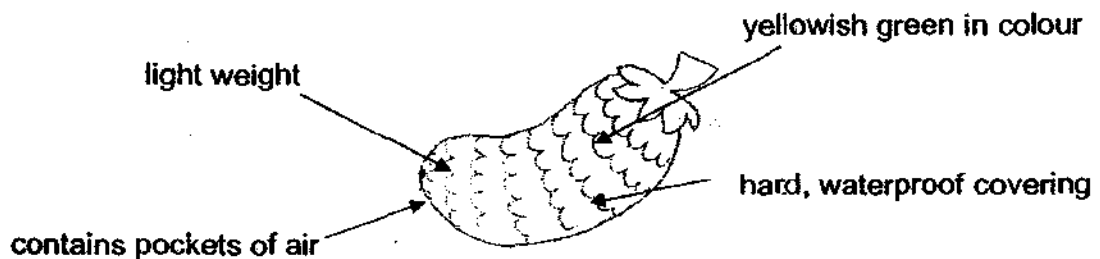

- Which method of seed dispersal do you think the fruit is dispersed?
Explain your answer clearly. [2]

Score	5
-------	---

38. The following statements detail how the human circulatory system works. Read the statements carefully.

Representative letter	Statement
P	The heart pumps blood to the lungs.
Q	The blood that is rich in oxygen flows to the heart.
R	Carbon dioxide in the blood is exchanged for oxygen.
S	Oxygen in the blood is exchanged for carbon dioxide.
T	The heart pumps blood rich in oxygen to the rest of the body.
U	The blood that is rich in carbon dioxide flows to the heart.

Complete the chart below by filling in the letters Q to U in the correct order to show how the human circulatory system works. [3]

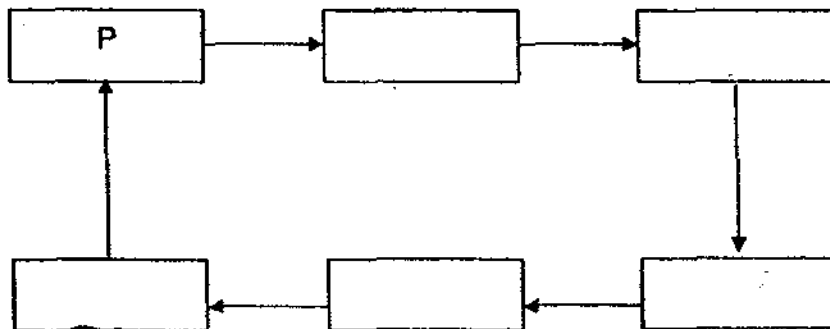

39. The chart below shows the organs as well as the substance that is absorbed by the blood in the organ. Fill in the missing blanks. [2]

	Organ	Substance absorbed into the blood
(a)		Water
(b)		Oxygen
(c)	Body cells	
(d)	Small intestine	

Score	5
-------	---

40. The diagram below shows how blood travels in and out of a heart. Study the diagram carefully and answer the questions that follow.

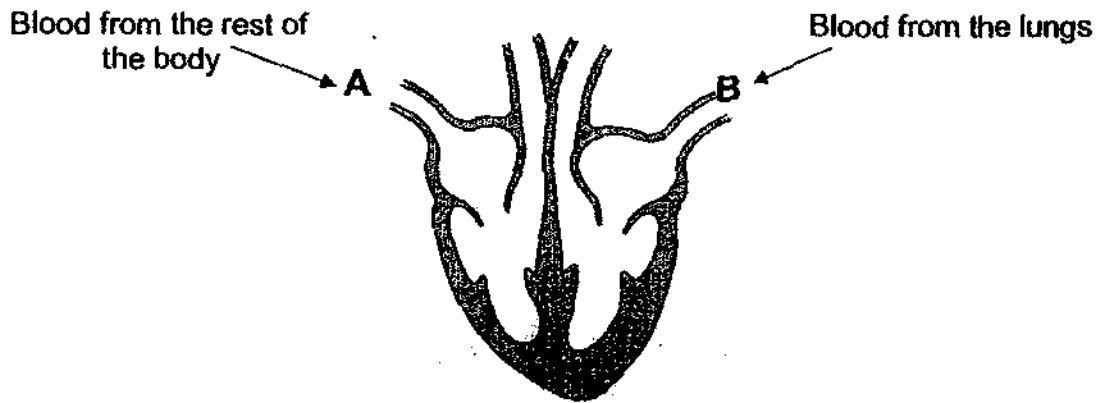

- (a) State one way in which Blood Vessels A and B are similar. [1]

- (b) State one way in which Blood Vessels A and B are different. [1]

41. The table shows 3 kinds of cells. Complete the table by indicating with a tick (✓) if the cell has the stated part. [3]

Parts of a cell	Types of Cells		
	Cheek cell from a boy	Cactus cell from the surface of its stem	Onion cell from an onion
Cell wall			
Cell membrane			
Cytoplasm			
Chloroplast			
Nucleus			

Score	5
-------	---

42. The diagram below shows how a bulb and 3 batteries are connected to 2 metal plates which are dipped into Liquid Q in the beaker.

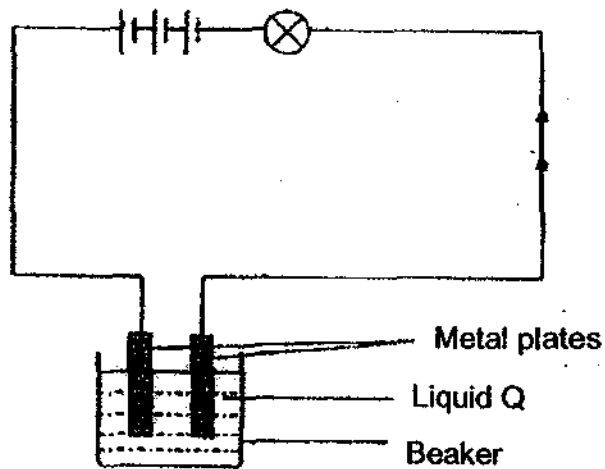

- (a) (i) The bulb lights up when the switch is closed. What can you conclude about liquid Q?

[1]

- (ii) Give a possible example of Liquid Q.

[1]

- b) If the metal plates are replaced with 2 pieces of wooden blocks, what would happen? Give a reason for your answer.

[2]

Score	4
-------	---

43. Jane set up a circuit with an iron nail suspended between two identical iron rods, A and B, which has an equal number of coils of wire around each rod.

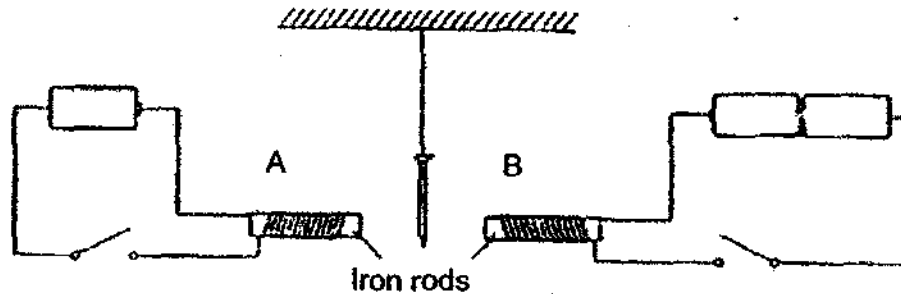

- (a) If both electric set-ups are closed at the same time, what will happen to the iron nail? [1]

- (b) Give a reason for your answer in (a). [2]

- (c) What can Jane do to the set-up if she wants the nail to move in the opposite direction without changing the number of batteries or the circuit arrangements? [1]

Score	
-------	--

44. The diagram below shows 4 lighted bulbs A, B, C and D in a circuit.

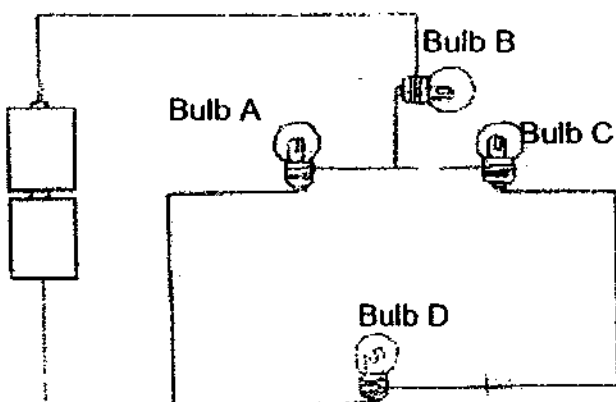

A switch is to be installed in the circuit so that two bulbs can be switched on and off while the other two remain lighted.

- (a) Mark an 'X' on the circuit above to show where the switch should be placed. [1]
- (b) Which bulb(s) (A, B, C or D) does the switch control? [1]

- (c) In the box below, complete the electric circuit by drawing in the wires in such a way that when one of the bulbs fuses, the other will still light up. [2]

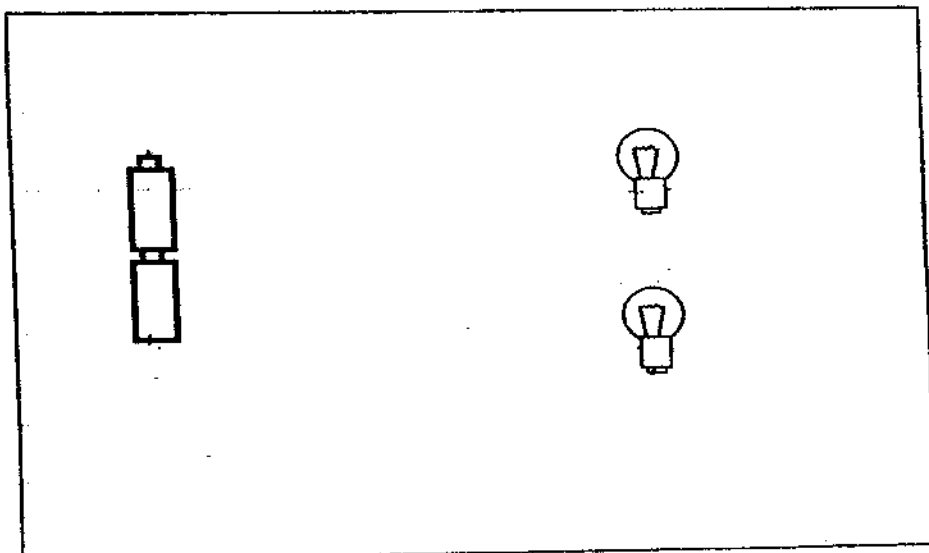

End of Paper

Score	4
-------	---

ANSWER SHEET

EXAM PAPER 2009

SCHOOL : NAN HUA PRIMARY
SUBJECT : PRIMARY 5 SCIENCE

TERM : SA2

Q1	Q2	Q3	Q4	Q5	Q6	Q7	Q8	Q9	Q10	Q11	Q12	Q13	Q14	Q15	Q16	Q17
4	2	4	2	3	1	1	3	2	4	3	3	2	2	3	2	4

Q18	Q19	Q20	Q21	Q22	Q23	Q24	Q25	Q26	Q27	Q28	Q29	Q30
3	1	2	3	2	2	2	4	3	1	1	2	2

31)a)Melting b)boiling c)evaporation d)condensation

32)a)T b)Impossible c)F d)T

33)a)A: windpipe B: lung
b)It allow us to in hale oxygen and exhale carbon dioxide.

34)a)The cell wall.
b)The chlorophyll.

35)Rod V and Y.

36)The larva moves around in stage X but the pupa in stage Y does not move.
The larva eats in stage X but pupa stop seating in stage Y.

37)a)A: dispersed by animal B: dispersed by wind.
b)A: grapes B: la lang
c)By water. It is light weight, contains current pockets of air and has a waterproof in water to be drifted to another place by water.

38)P → R → T
U ← S ← T

39)a)Large intestine b)lungs c)waste materials d)digested food

40)a)Both are veins.

b)Blood vessel A carry blood rich in carbon dioxide while Blood vessel B carry blood rich in oxygen.

41)

Parts of a cell	Types of Cells		
	Cheek cell from a boy	Cactus cell from the surface of its stem	Onion cell from an onion
Cell wall		/	/
Cell membrane	/	/	/
Cytoplasm	/	/	/
Chloroplast		/	
Nucleus	/	/	/

42)a)i)Liquid Q is a good conductor of electricity. ii)Lemon juice.

b)The bulb would not light up because wood is a insulator of electricity.

43)a)It would go to B.

b)As there are more batteries in B, there will be more electric current flowing to Rod B and thus it will be a stronger electric magnet.

c)She can increase the number of coils around iron rod A.

44)a)

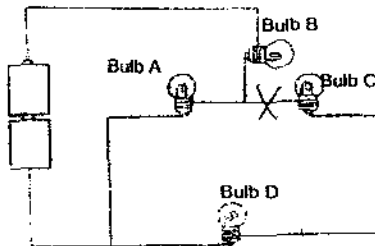

b)The switch controls bulb C and D.

c)

