

**NANYANG PRIMARY SCHOOL**

**PRIMARY FIVE SCIENCE**

**SEMESTRAL ASSESSMENT 2**

**BOOKLET A**

27 October 2009

1 h 45 min

Name : \_\_\_\_\_ ( )

Class: Primary \_\_\_\_\_ ( )

**Marks Scored:**

Booklet A:		60
Booklet B :		40
Total :		100

Parent's signature: .....

**DO NOT OPEN THIS BOOKLET UNTIL YOU ARE TOLD TO DO SO.  
FOLLOW ALL INSTRUCTIONS CAREFULLY.**

**Booklet A consists of 19 printed pages including this cover page.**

**Section A (30 x 2 = 60 marks)**

For each question, 1 to 30, four options are given. One of them is the correct answer. Make your choice (1, 2, 3 or 4). Shade the correct oval (1, 2, 3 or 4) on the Optical Answer Sheet provided.

1. The diagram below shows the fruit of a plant Z. The fruit has been split open.

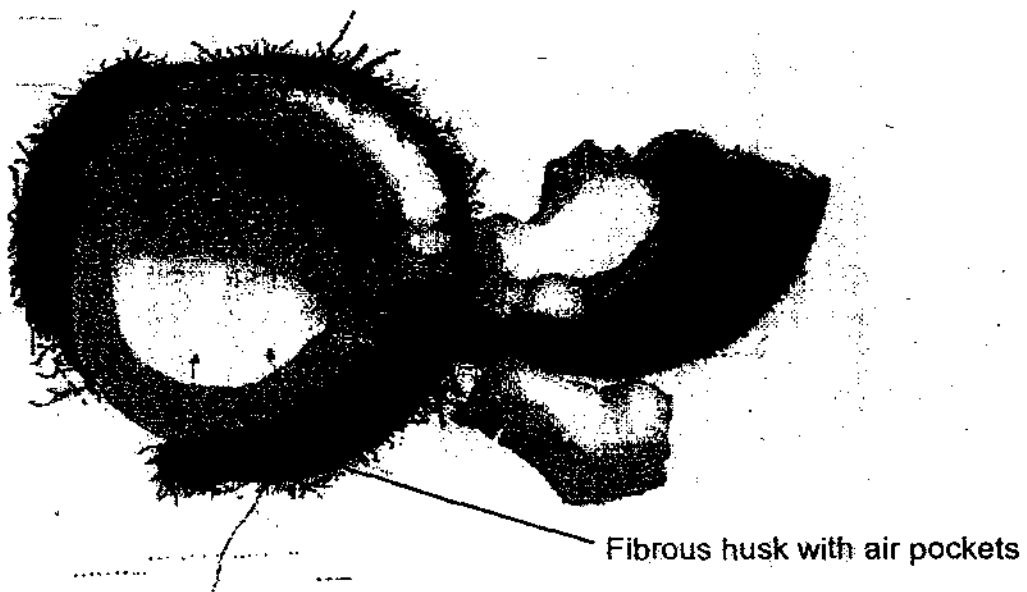

Based only on the above diagram, what can be inferred <sup>from</sup> about the fruit of plant Z?

- A Plant Z produces flowers.
- B The fruit of plant Z is dispersed by wind.
- C The flesh of the fruit of plant Z is juicy and tasty.
- D The fibrous husk helps the fruit of plant Z to float.

- (1) D only
- (2) A and D only
- (3) A, C and D only
- (4) A, B, C and D only

2. The walls of the gullet, stomach, small intestine and large intestine are muscular. Which of following statements describe(s) the functions of these muscles?

- A The muscles help to move food along the digestive <sup>systems</sup> tract.
- B The muscles help to mix the digestive juices and food.
- C The muscles break down the food into simpler substances.

- (1) A only
- (2) A and B only
- (3) B and C only
- (4) A, B and C

3. Pooja conducted an experiment by dropping three shorea fruits, A, B and C, with wing-like structures of different length from the same height and recording the time required for the fruit to hit the ground. The fruits are shown below.



Which of the following is a hypothesis of her experiment?

- (1) Shorea fruits are dispersed by wind.
- (2) The wing-like structures are very important.
- (3) Fruit C fell to the ground in the shortest amount of time.
- (4) The longer the length of the wing-like structure, the longer the time taken for the fruit to hit the ground.

4. Which of the following statements is true about the cells in the human body?

- (1) The human body is made up only of living cells.
- (2) All cells in the human body perform the same function.
- (3) Cells in our body are continually dying and being replaced.
- (4) All cells in the human body have a cell membrane, cytoplasm and nucleus.

5. The chart below is used to classify organisms A, B, C and D.

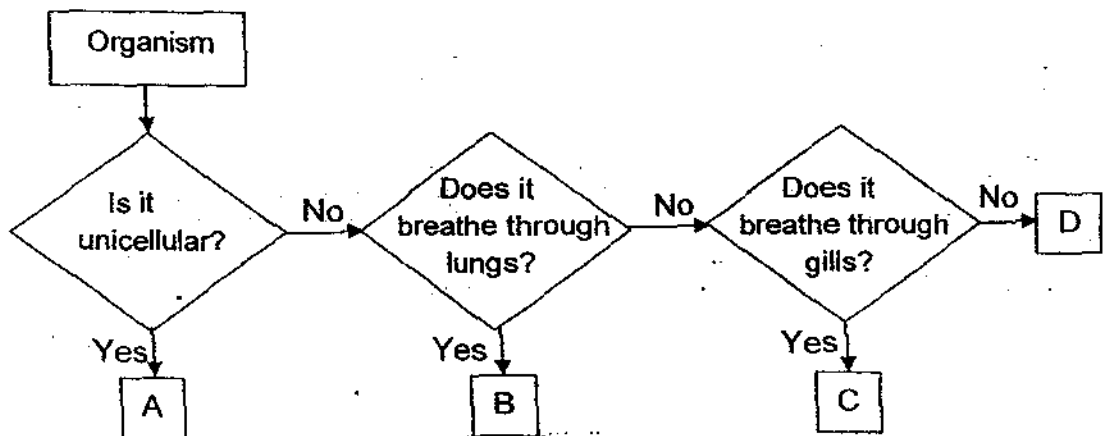

Which one of the following options best represents A, B, C and D?

	A	B	C	D
(1)	Cheek cell	Platypus	Goldfish	Mosquito
(2)	Amoeba	Human	Whale	Cockroach
(3)	Paramecium	Shark	Trout	Frog
(4)	Yeast	Frog	Swordtail	Housefly

6. Jimmy carried out an iodine test on food R. He added a few drops of iodine to R and observed that the iodine solution turned dark blue. Based on his observation, which of the following statements is/are definitely true about food R?

- A R contains starch.
- B R is either rice or noodles.
- C R is a plant part that stores food.

- (1) A only
- (2) A and B only
- (3) A and C only
- (4) A, B and C only

7. Which one of the following statements about plant cells is true?

- A The cell wall gives the cell a regular shape.
- B The nucleus controls all the activities of the cell.
- C The chloroplasts allow the plant cell to produce its own food.
- D The cytoplasm controls all the substances entering and leaving the cell.

- (1) B only.
- (2) A and B only
- (3) A, B and C only
- (4) B, C and D only

8. Which of the following statements about the circulatory and respiratory systems is true?

- (1) The red blood cells carry food and oxygen.
- (2) All arteries carry blood away from the heart.
- (3) The blood vessels in the nose absorb oxygen from the air that we inhale.
- (4) The diaphragm moves up when we breathe in and moves down when we breathe out.

9. A group of pupils counted the plants and animals found in a garden. They represented their results in the graph below.

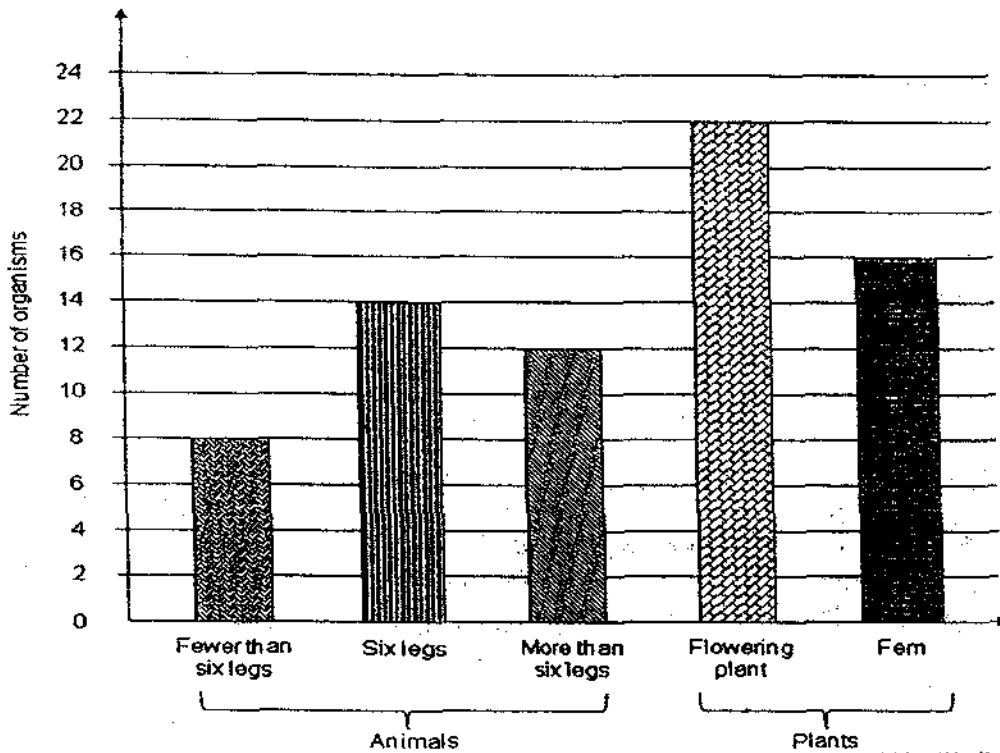

Which of the following statements about the plants and animals in the garden are definitely correct?

- A There are more insects than other types of animals.
- B There are 34 populations of animals.
- C There is only one garden community.
- D There are at least six populations of plants and animals.

- (1) A and B only
- (2) A and C only
- (3) A, C and D only
- (4) A, B, C and D only



13. A plant was placed in a container of water with black dye and left to stand overnight. The next day, the stem was cut and the cross section was shown below.

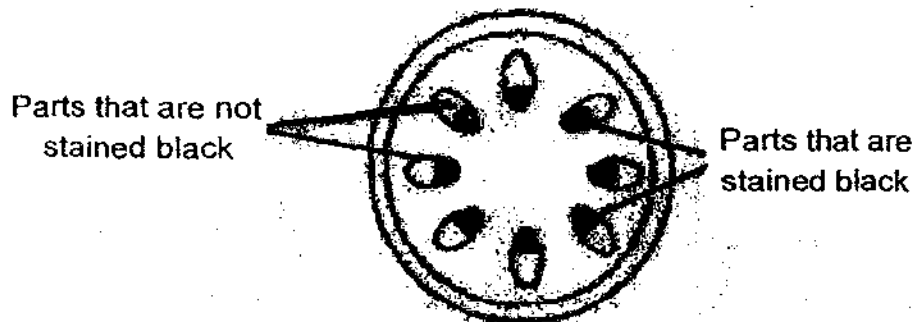

Which of the following inferences could be made from the above observation?

- (1) Certain parts of the plant do not transport water.
  - (2) The parts stained black also transports dissolved air to the leaves.
  - (3) Water is transported in the stem because the stem is semi-permeable.
  - (4) Water is transported from the leaves to the stem to the whole plant by the parts stained black.
14. Mr. Tan wishes to select a material to make raincoats. Besides having a material which is waterproof, which other properties of the material must he consider?
- A Mass  
B Flexibility  
C Degree of transparency
- (1) A and B only
  - (2) A and C only
  - (3) B and C only
  - (4) A, B and C

15. Jane wanted to test how respiration affects the amount of carbon dioxide in the air. She set up her experiment as shown below with two dataloggers to detect the amount of carbon dioxide in the air

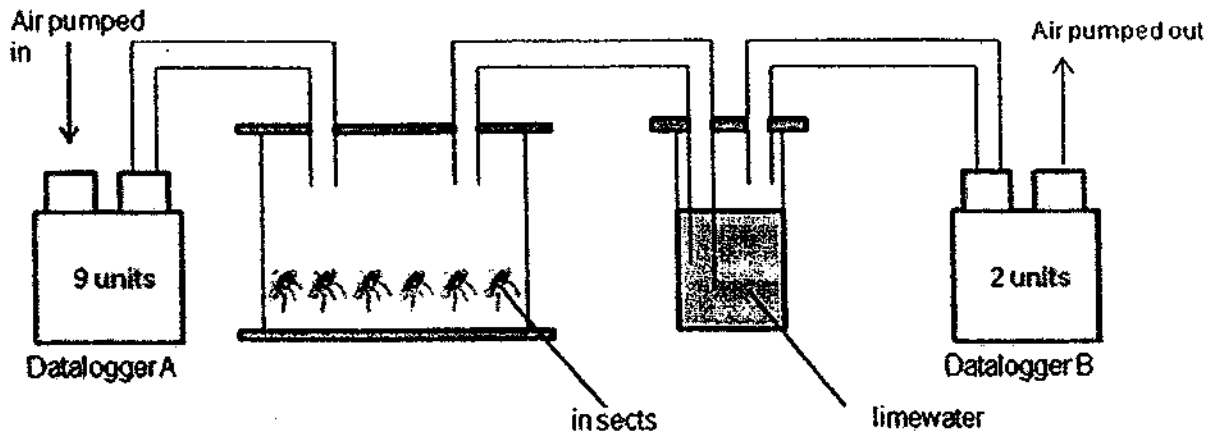

Datalogger A showed a reading of 9 units while datalogger B showed a reading of 2 units. Based on the set-up and the data collected, which of the following statements explains the data she had collected?

- (1) The insects used the carbon dioxide in the air to make food.  
 (2) Some of the carbon dioxide was removed when the limewater turned chalky.  
 (3) The carbon dioxide that turned the limewater chalky came only from the insects when they respired.  
 (4) The readings from the dataloggers showed that respiration of the insects used up carbon dioxide.
16. Four classmates, Ali, Bob, Lin and Tam, were discussing what they had learnt from their lesson on electricity.

Ali : Only metals are conductors of electricity.  
 Lin : Solar energy can be converted to electricity.  
 Bob : Electricity used in most houses comes from power stations.  
 Tam : An air-conditioner uses the same amount of electricity as a standing fan.

Which pupils made the wrong statements?

- (1) Ali and Lin  
 (2) Bob and Lin  
 (3) Ali and Tam  
 (4) Bob and Tam

17. The graph below shows the changes in temperature of water in a container over time.

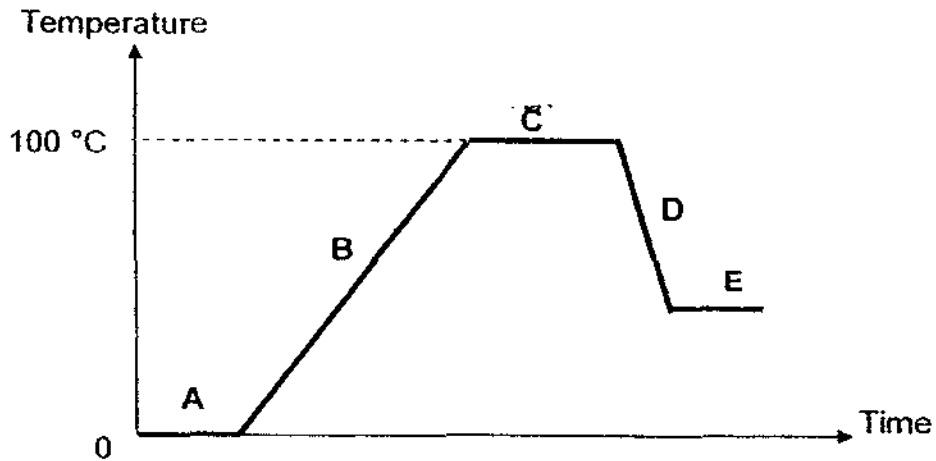

Which parts of the graph, A, B, C, D or E, show(s) the water gaining heat?

- (1) D only  
 (2) A, B and C only  
 (3) A, C and E only  
 (4) A, B and E only

18. The parts of the bulb shown below are labelled A to E.

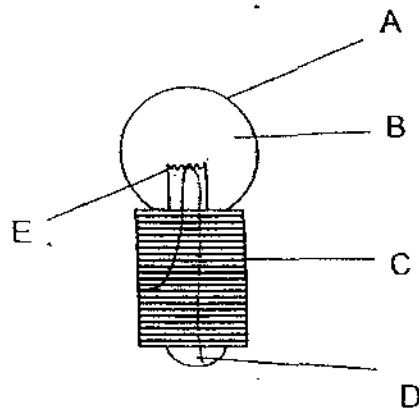

Which parts of the bulb are conductors of electricity?

- (1) C, D and E only  
 (2) A, C, D and E only  
 (3) B, C, D and E only  
 (4) A, B, C, D and E

19. When Siti looked at the reflections of the letters 'F' and 'X' in the mirror, she saw that the image of letter 'F' has been inverted but not that of 'X'.

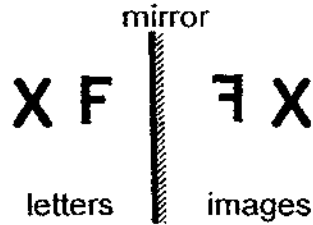

Next, Siti placed the word 'DEHYDRATION' before a mirror. How many letters are inverted in the reflection of the word?



(1) 5  
(3) 3

(2) 6  
(4) 4

20. Zhikai shone his torch on the mug shown below.



He held his torch at various positions to cast different shadows of the mug.



A



B



C



D

Which of the above shadows could be those cast by the mug?

(1) A, B and C only  
(3) A, C and D only

(2) B, C and D only  
(4) A, B, C and D

21. Some electrical appliances are grouped using the classification chart below.

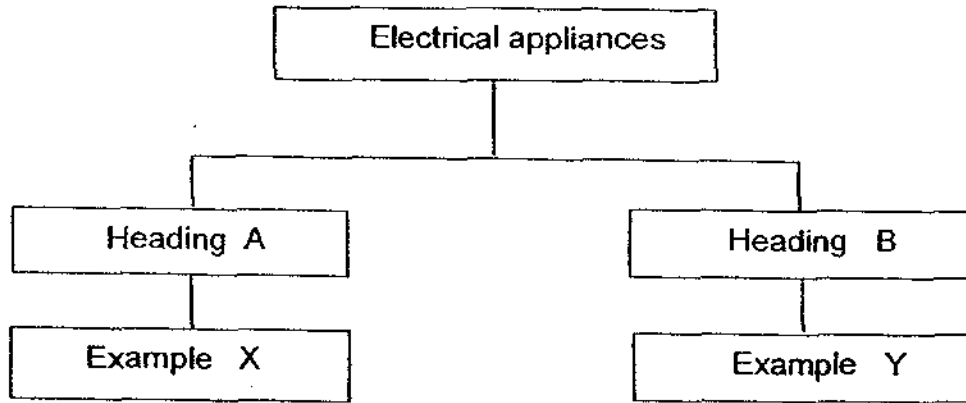

Which one of the following options below provides the most suitable headings for A and B, and examples for X and Y?

	A	X	B	Y
(1)	Produces useful heat	oven refrigerator	Produces unwanted heat	bulb generator
(2)	Uses electricity	computer refrigerator	Produces electricity	electric eel car battery
(3)	Produces unwanted heat	generator iron	Produces useful heat	oven hair dryer
(4)	Produces electricity	fan electric eel	Uses electricity	oven car battery

22. Study the diagram of a circuit shown below.

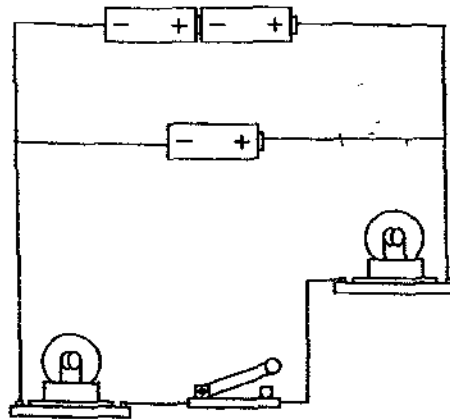

Which one of the circuit diagrams below best represents the actual circuit shown above?

(1)

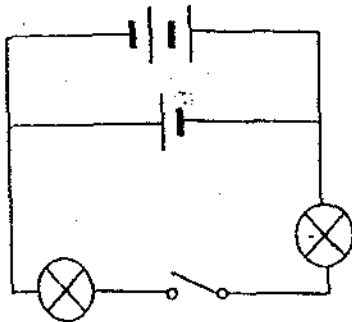

(2)

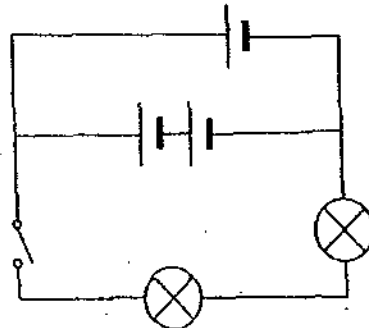

(3)

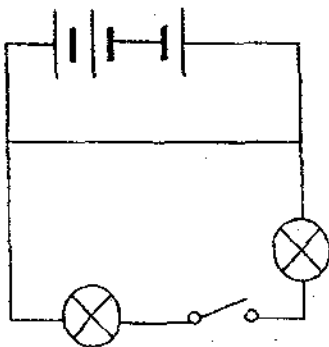

(4)

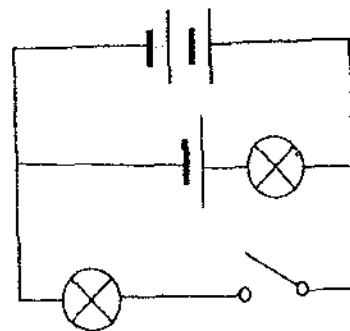



25. Peter set up a circuit as shown below. An object P with ends labelled X and Y was connected to the circuit and the bulb lighted up when the switch was closed.

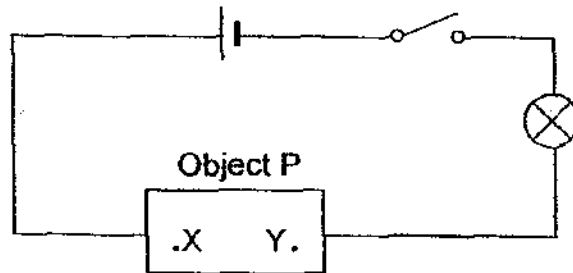

Peter then removed the object P and turned it the other way before connecting it to the circuit again as shown in the diagram.

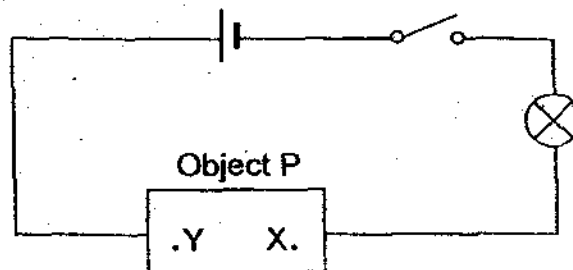

When he closed the switch, the bulb continued to light up. Which one of the following options consisted only of objects that could be P?

- (1) switch, paper
- (2) battery, bulb
- (3) glass rod, fan
- (4) magnet, wire

26. Peter made two electromagnets using Rods A and B as shown below. He used identical paper clips for a test he conducted.

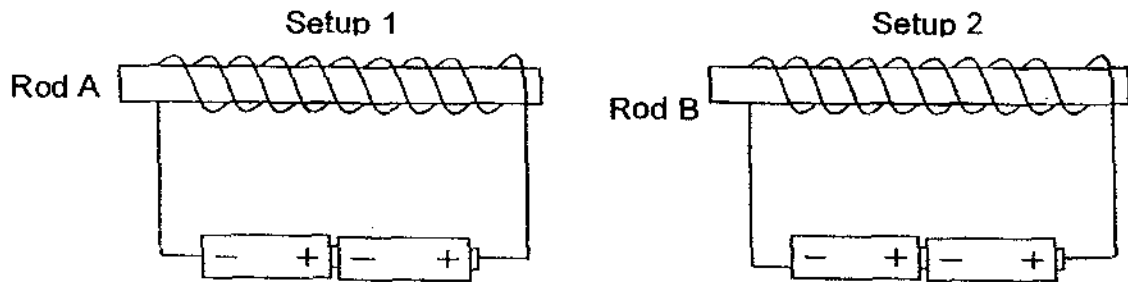

He found that the electromagnet in Setup 1 could attract 7 paper clips while the electromagnet in Setup 2 could attract 5 paper clips. What is a possible reason for the difference in results?

- (1) Weaker batteries are used in Setup 2.
- (2) Rod A is made of iron but Rod B is made of copper.
- (3) The paper clips in Setup 1 are heavier than those in Setup 2.
- (4) The connecting wires in Setup 1 are thicker than those in Setup 2.

27. In which of the following circuits will the 2 bulbs light up?

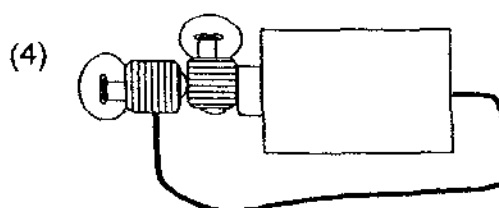
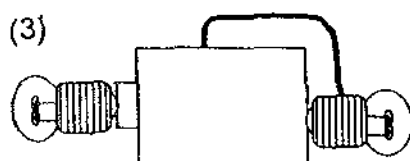
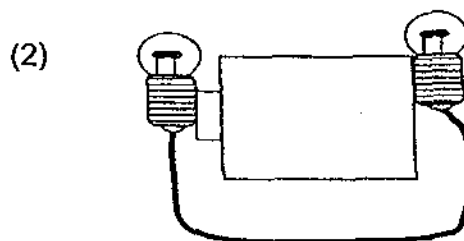
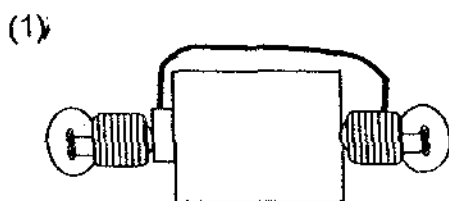

28. Study the three circuits, A, B and C, below.

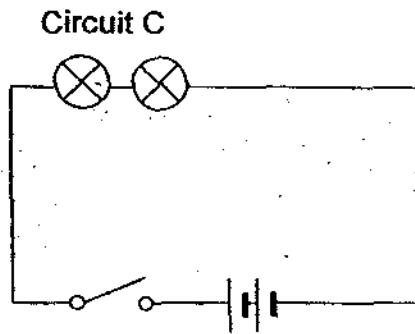
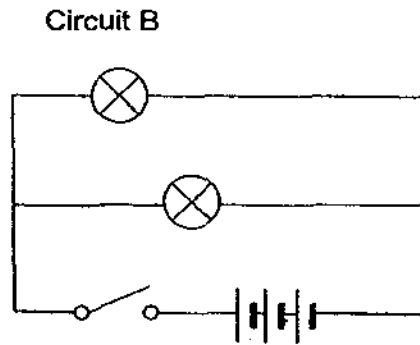
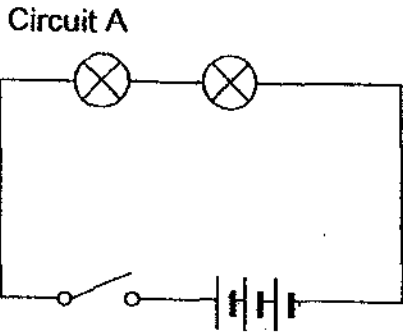

Arrange these circuits in order of brightness of the bulbs when the switches are closed, starting from the dimmest to the brightest.

- (1) CAB  
(3) BAC

- (2) ABC  
(4) ACB

29. Minah set up an electric circuit as shown in the circuit diagram below.

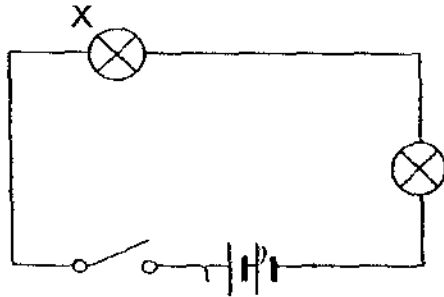

To increase the brightness of Bulb X, she made several changes to the circuit. The diagrams below show the changes she had made.

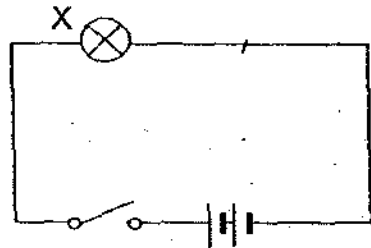

Change A

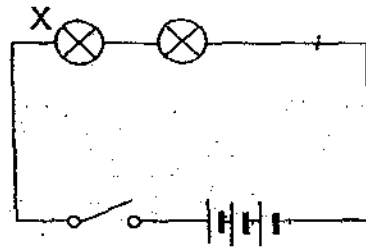

Change B

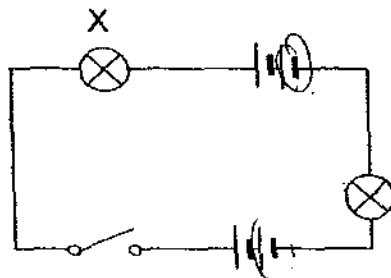

Change C

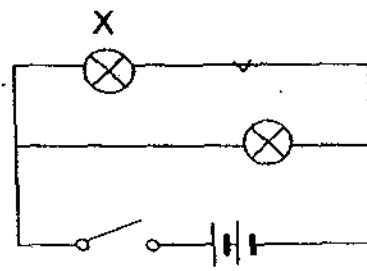

Change D

Which of these changes would ensure that Bulb X is brighter than before, when the switch is closed?

- (1) Change D only
- (2) Changes A and B only
- (3) Changes A, B and D only
- (4) Changes A, B, C and D

30. Jane set up the circuit shown below. Nichrome is a metal.

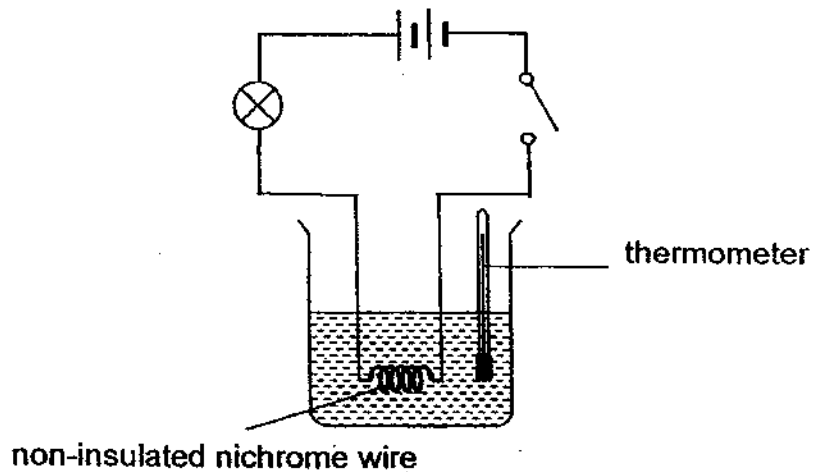

Which of the following statements described the observation(s) Jane would make after the switch is closed for 20 minutes?

- A The bulb lighted up.
- B The bulb did not light up.
- C The thermometer showed an increase in temperature.
- D The thermometer did not show any change in temperature.

- (1) B only
- (2) D only
- (3) A and C only
- (4) B and D only

**NANYANG PRIMARY SCHOOL**

**PRIMARY FIVE SCIENCE**

**SEMESTRAL ASSESSMENT 2**

**BOOKLET B**

**27 October 2009**

**1 h 45 min**

**Name :** \_\_\_\_\_ (     )

**Class: Primary** \_\_\_\_\_ (     )

**Marks Scored:**

<b>Booklet A:</b>		<b>60</b>
<b>Booklet B :</b>		<b>40</b>
<b>Total :</b>		<b>100</b>

**Parent's signature:** \_\_\_\_\_

**DO NOT OPEN THIS BOOKLET UNTIL YOU ARE TOLD TO DO SO.  
FOLLOW ALL INSTRUCTIONS CAREFULLY.**

**Booklet B consists of 17 printed pages including this cover page.**

**Section B (40 marks)**

Write your answers to questions 31 to 44 in the spaces provided.  
Marks will be deducted for misspelt key words.

31. The maps below show the locations of plant X along the banks of a river in the years 1990 and 2000.

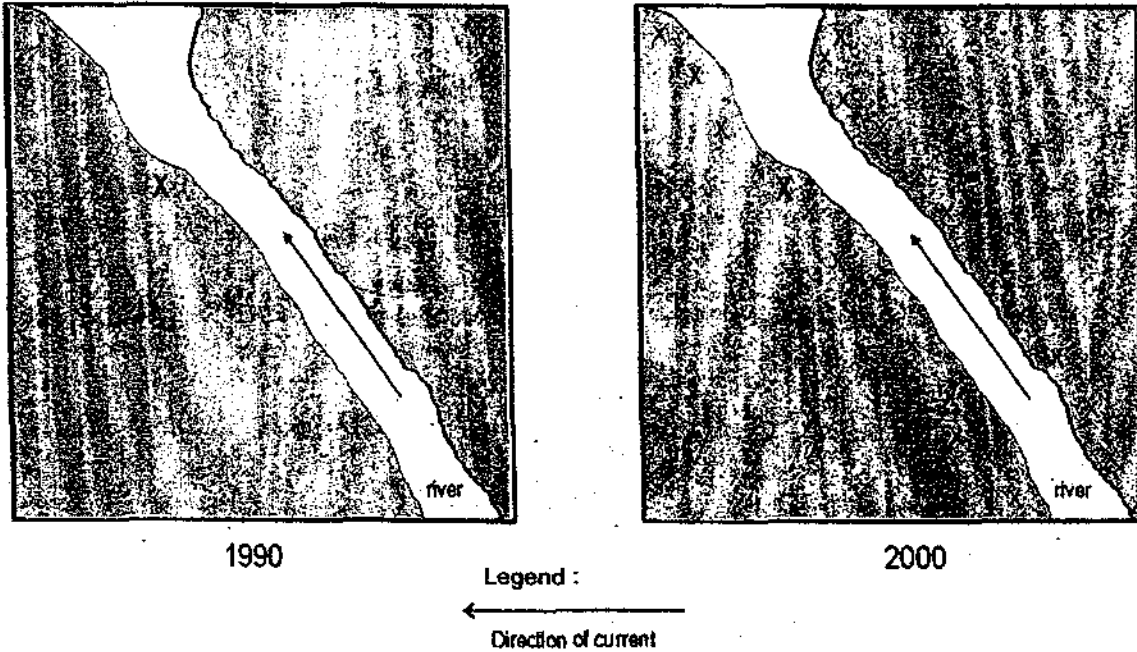

(a) What is the most likely method of dispersal for plant X?  
Explain your answer. (2m)

---

---

---

---

(b) Name a characteristic of its fruit or seed that helps it in its dispersal. (1m)

---

---

32. The following diagrams illustrate the development of a chick from a fertilised egg on day 5, 10, 15 and 20. The yolk sac stores food.

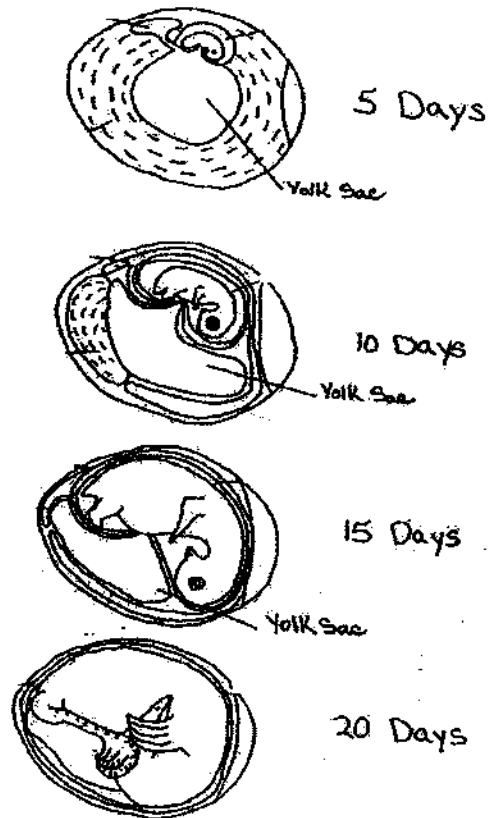

(a) Explain why the yolk sac decreases in size from Day 5 to Day 15 as the chick becomes bigger. (1m)

---

---

---

(b) State two other conditions required by the chick for its development. (1m)

---

---

33. Daphne set up the following experiment to find out if cells divide and increase in number more quickly when an electric current is passed through it.

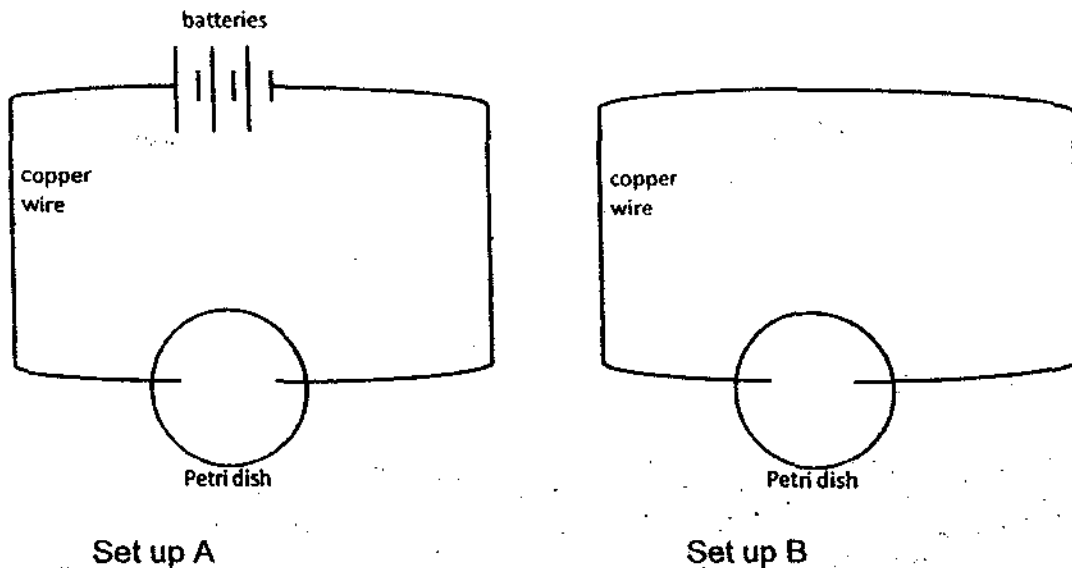

She filled each Petri dish with some water and nutrients and placed some cells in each Petri dish. She then recorded the area occupied by the cells at regular intervals.

- (a) Water is easily absorbed into the cell through the cell membrane. Animal cells have been observed to burst if left in water for too long. Explain why she should use plant cells for her experiment. (2m)

---

---

---

---

- (b) State two variables that Daphne should keep constant for a fair test. (1m)

---

---

Daphne observed that the rate of cell death was much greater than the rate of cell division when there was no current passing through the cells. The results from set-up A are shown below.

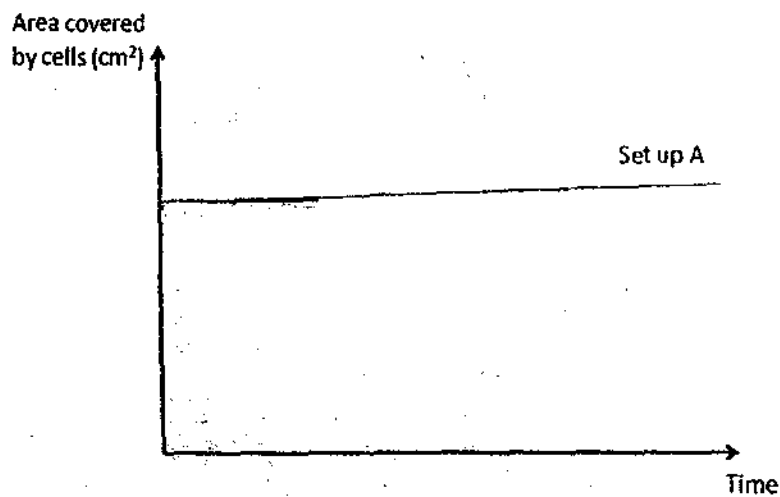

(c) In the same graph above, draw the results that Daphne would expect to see from set-up B. (1m)

34. The diagram below shows a part of a human organ system.



(a) On the diagram above, identify and label the part of the system where digestion no longer occurs. (1m)

(b) Part C is richly supplied by capillaries.  
Give a possible reason why part C is richly supplied with blood capillaries. (1m)

(c) Name a substance produced by this part<sup>x</sup> of the system to break food down into simpler substances. (1m)

35. The table below shows the breathing rates when George is performing different activities of various intensities

Activity	Breathing rate (breaths per minute)
Sleeping	42
Playing soccer	103
Walking up a flight of stairs	63

- (a) Based on the above table, what is the relationship between the intensity of the activity and George's breathing rate. (1m)

---

---

- (b) George then measured his breathing rate while he was sitting at his desk in class. Based on the data above, predict his breathing rate. (1m)

---

---

- (c) State what happens to George's heart rate when his breathing rate increases. (1m)

---

---

36. Saravanan placed some beans into a beaker as shown below. He placed the beaker in a cupboard.

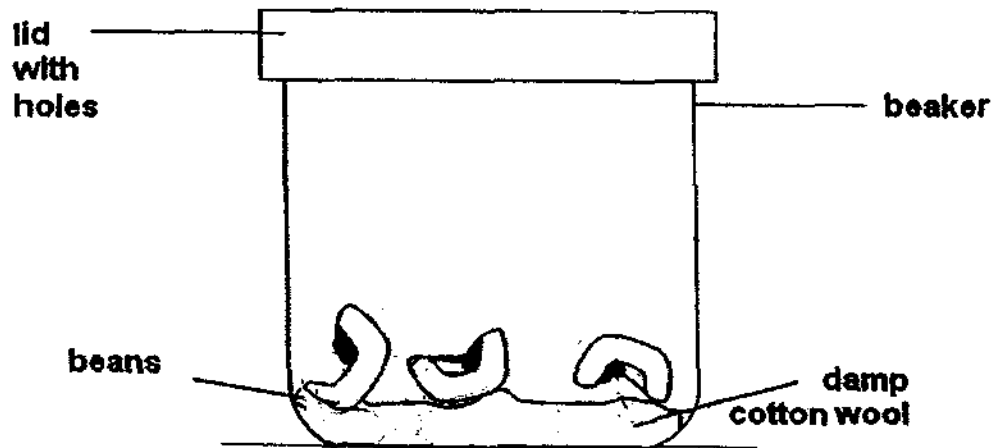

- (a) In the diagram above, draw and label how the roots and shoots would grow after a few days. (2m)
- (b) Explain why Saravanan used a lid with holes for his experiment. (1m)

---

---

37. Donald conducted an experiment to find out the conditions required for the germination of seeds. He used four seeds, A, B, C and D. The table below shows the conditions that were provided for each of the seeds.

Seed	Conditions			
	Light	Air	Water	Temperature (°C)
A	Present	Absent	Present	25
B	Absent	Present	Present	75
C	Present	Present	Present	30
D	Absent	Present	Present	0

- (a) What could he do to ensure that his test is a fair test? (½m)

---

---

- (b) After a few days, which seeds, A, B, C or D, would germinate? (½m)

---

- (c) In this experiment, Donald grew his seeds on cotton wool instead of soil. Explain why he did not need to use soil for his experiment. (1m)

---

---

38. Chloe wanted to measure how the amount of oxygen in the air is affected by the amount of light that the plant is exposed to. She placed a plant and a datalogger in a transparent plastic box as shown.

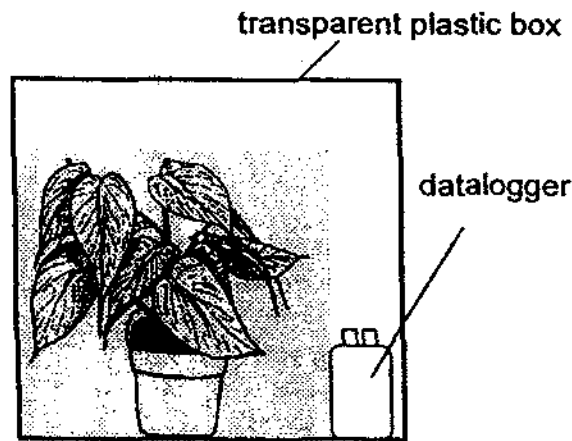

The plastic box was placed in the basketball court for 24 hours. The graph below shows the readings obtained from the datalogger over time.

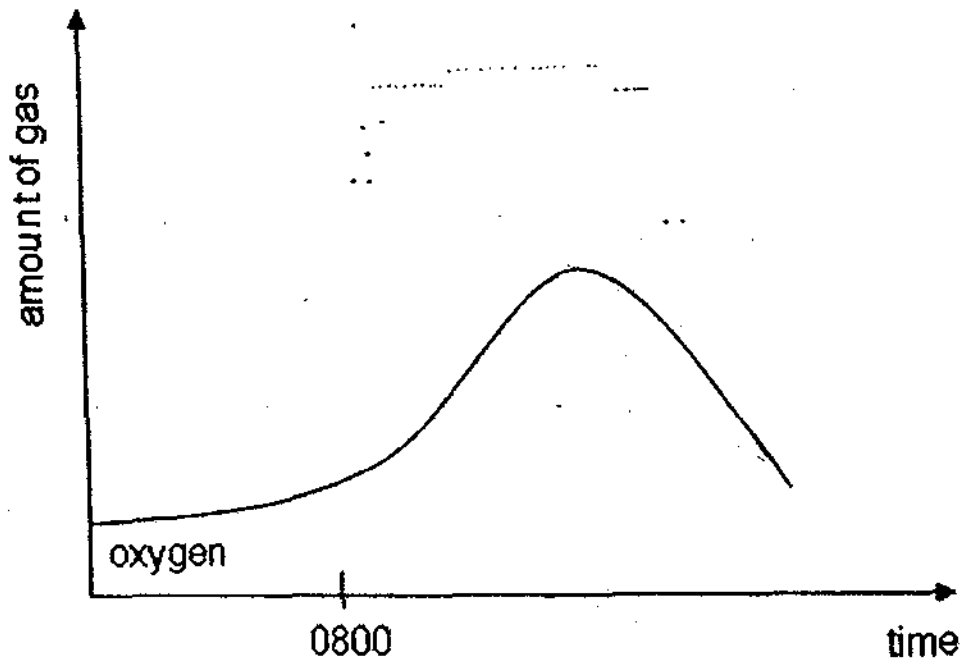

- (a) Mark an "X" on the time axis of the graph above to identify the time nightfall was likely to have occurred and the plant no longer received any sunlight. (1m)

(b) The bar graph below shows the composition of air in the atmosphere.

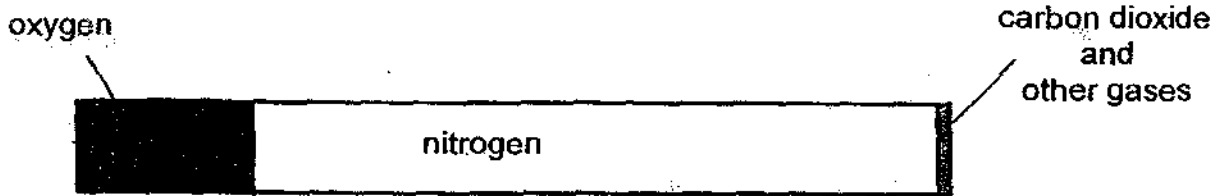

The graph of the amount of oxygen in the air in the plastic box has been drawn for you below. On the same graph, draw the graph you would obtain to show the amount of nitrogen in the air in the box over time. (1m)

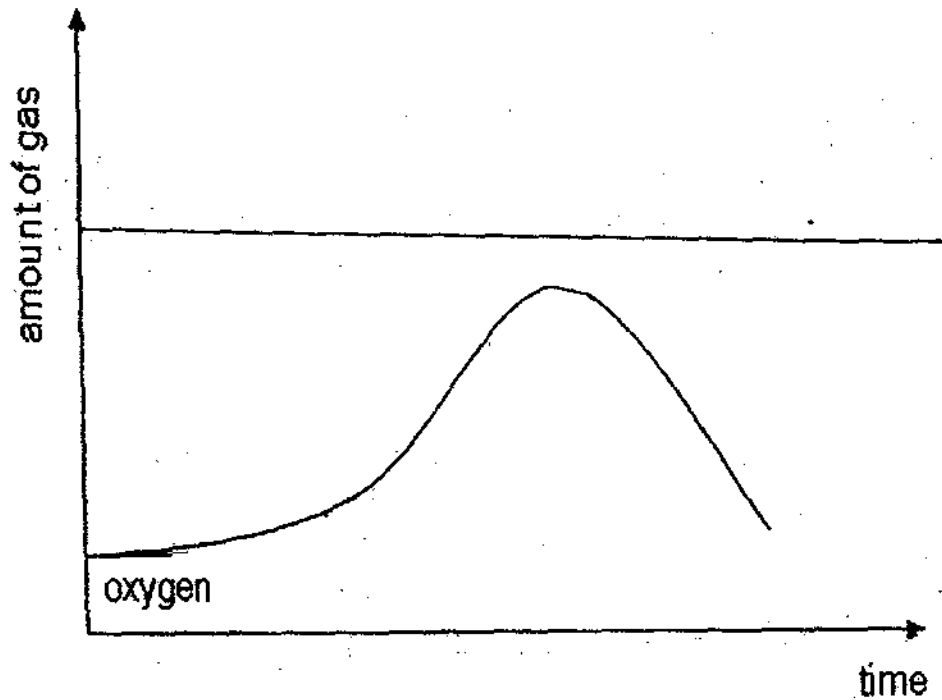

39. Dexter carried out an experiment on 3 materials, P, Q and R. He conducted his experiment using a datalogger as follows:

- ◆ Place a torchlight directly in front and 10 cm from the light sensor of the datalogger.
- ◆ Record the reading.
- ◆ Place material P between the torchlight and light sensor. Material P is 5 cm from the light sensor.
- ◆ Record the reading. Repeat 2 more times.
- ◆ Repeat the experiment with materials Q and R respectively.

Dexter's results were recorded as follows:

Reading when no material was placed between the light sensor and torchlight = 5000 lux

Materials	1 <sup>st</sup> reading (lux)	2 <sup>nd</sup> reading (lux)	3 <sup>rd</sup> reading (lux)
P	2500	2490	2510
Q	0	0	0
R	4950	4950	4980

Dexter chose one of the materials to make curtains for his room. He wanted a material which allows light partially into the room on a bright day...

Which material, P, Q or R, should Dexter choose to make his curtains? Explain your answer based on the data that he had collected. (2m)

---

---

---

---

40. The diagram below shows a box with 4 mirrors, A, B, C and D in it. The lid of the box has two holes to allow the images of the ball to be seen by the eye.

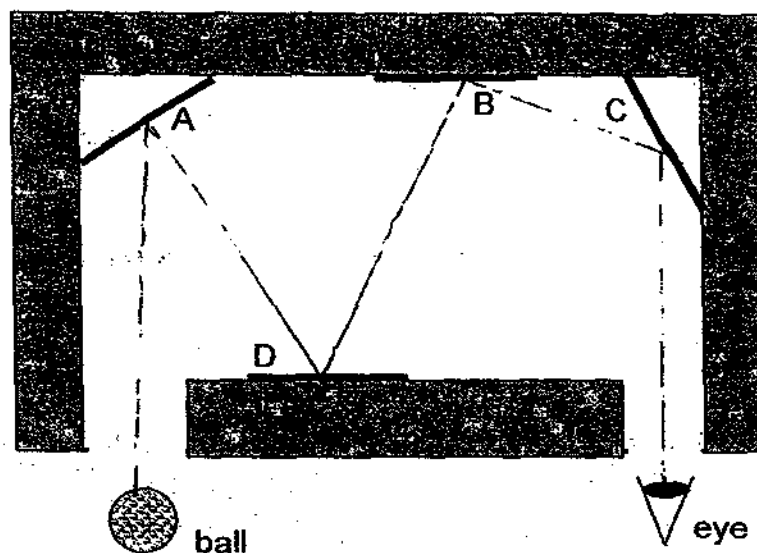

- (a) Which two mirrors can be removed so that no images of the ball are seen by the eye? (1m)

---

- (b) What property of light allows us to see our image in the mirror? (1m)

---

---

---

41. Study the classification table below. It shows the sources from which the various materials are obtained.

From animals	From the ground	From plants
leather	coal	cotton
feathers	clay	silk
wool	plastic	paper

- (a) Write down the material/s that has/have been classified wrongly. (1m)

---

- (b) Name a material in the table which is a fuel for producing electricity. (1m)

---

- (c) Explain why wool is used to make winter jackets. (1m)

---

---

42. The diagram below shows the top view of two rooms in Helen's house. In Room 1, Helen uses a switch to turn on two lamps at the same time. However, when one lamp fuses, the other would not light up. In Room 2, there is a lamp and a switch to turn it on. The lamp in Room 1 can be switched on without switching on the lamp in Room 2.

- (a) Complete the circuit below, using symbols to show how the lamps and switches are connected to the power supply. (3m)

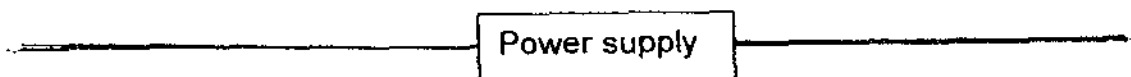
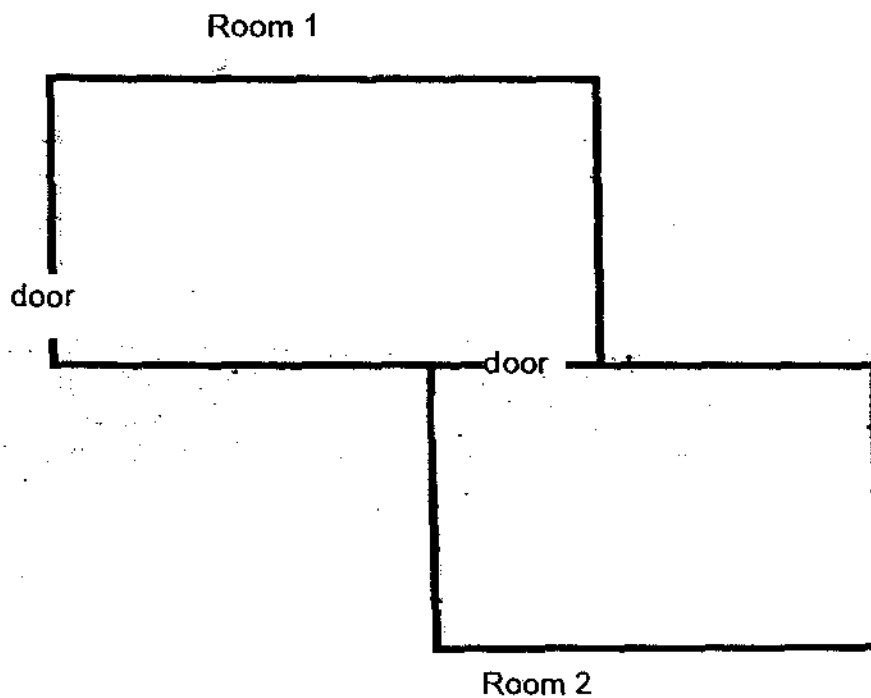

- (b) State 1 way to reduce the amount of electricity required for lighting our house without decreasing the number of lights. (1m)

---



---

43. Tom made a 10-cm square circuit card. He used five paper fasteners, A, B, C, X and Y, and two 14-cm long wires. His friend used a circuit tester to test pairs of the fasteners and recorded the results in the table below.

Bulb did not light up	Bulb lights up
A and B	X and Y
A and X	C and Y
B and C	C and X

- (a) Based on the results above, draw one possible arrangement of wires on the card below (not drawn to scale). (1m)

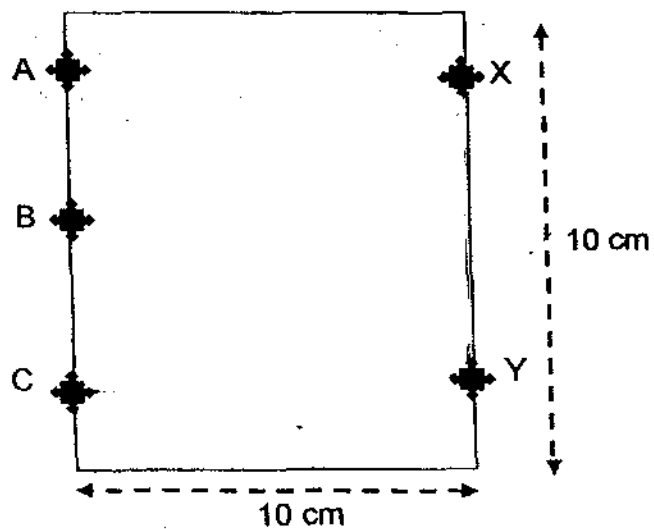

- (b)(i) What would you observe when fasteners B and Y are tested using the circuit tester? (1m)

---

- (ii) Explain your answer. (1m)

---



---



---

44. Jiale set up an experiment to find out which material, P or Q, is a better conductor of heat. The iron nails, A and B, are similar and sections X and Y are similar in thickness.

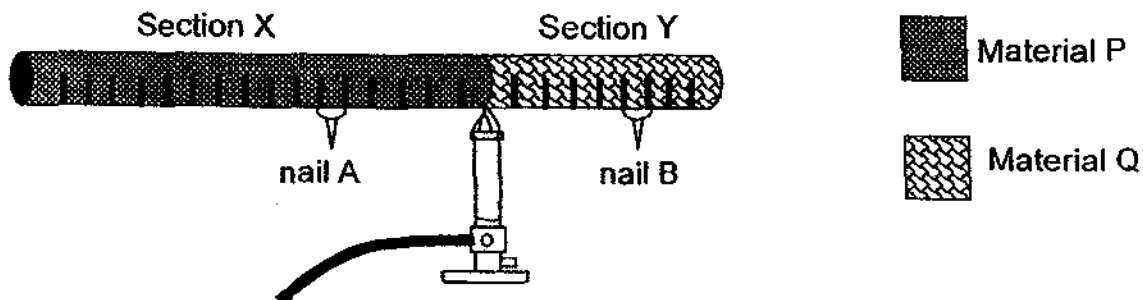

- (a) What could be Jiale's hypothesis for his experiment? (1m)

---



---

- (b) Jiale repeated his experiment three more times before he reached the conclusion. Why must he repeat his experiment a few times? (1m)

---



---

- (c) If nail A drops off before nail B, state the conclusion of Jiale's experiment. (1m)

---



---

- (d) Explain whether it is a fair experiment to compare how well material P and Q conduct heat when Section X is longer than Section Y. (1m)

---



---

End of paper

# ANSWER SHEET

EXAM PAPER 2009

SCHOOL : NANYANG PRIMARY  
SUBJECT : PRIMARY 5 SCIENCE

TERM : SA2

Q1	Q2	Q3	Q4	Q5	Q6	Q7	Q8	Q9	Q10	Q11	Q12	Q13	Q14	Q15	Q16	Q17
2	2	4	3	4	1	3	2	2	3	4	2	1	1	2	3	2

Q18	Q19	Q20	Q21	Q22	Q23	Q24	Q25	Q26	Q27	Q28	Q29	Q30
1	1	2	2	3	4	2	4	1	2	1	3	3

31)a)Animals. The plants are dispersed against the current of the river.  
b)Fleshy and ju

32)a)The yolk sac provides food for the developing chick. As the chick grew bigger, it consumed the food, therefore the yolk sac decreased in size.  
b)Warmth and Air.

33)a)A plant cell has a cell wall which gives the plant it's regular shape and would not allow the cell to burst.

b)The amount of water in each Petri Dish.

c).



34)a)

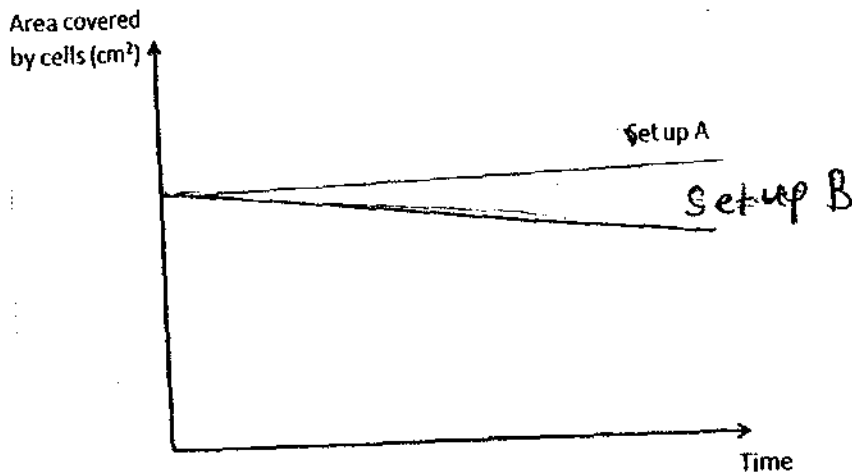

b) The small intestine is richly supplied with blood capillaries so that the small intestine can pass the digested food into the blood stream to be circulated to the rest of the body. Capillaries are very thin, so the digested food could pass through easily.

c) Digestive Juices.

35)a) The more vigorous the activity, the higher the breathing rate.

b) 52.

c) His heart rate would increase when his breathing rate increases.

36)a)

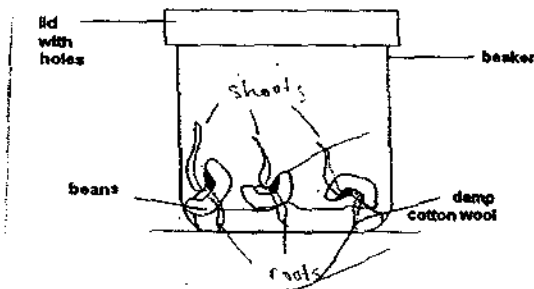

b) Beans need oxygen to germinate.

37)a) He should make sure that the seeds are of the same type of plant.

b) C.

c) No mineral salts are required for germination.

38)a)

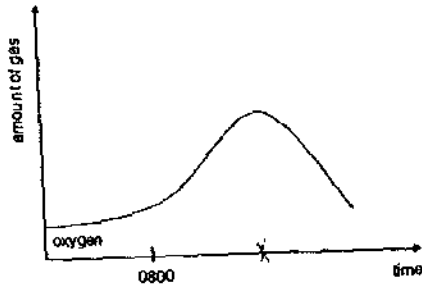

b)

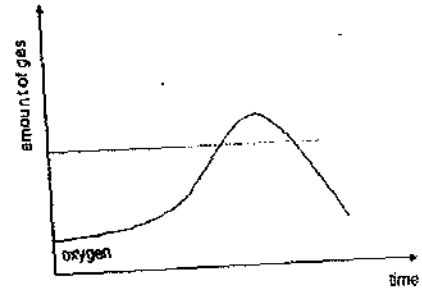

39)Material P. Light can partially pass through material P on a bright day as the light sensor could record the readings.

40)a)A and C.

b)Light travels in a straight line therefore, it enables us to see things.

41)a)Plastic, silk.

b)Coal.

c)Wool is a bad conductor of heat, therefore, it keeps you warm during winter.

42)a)

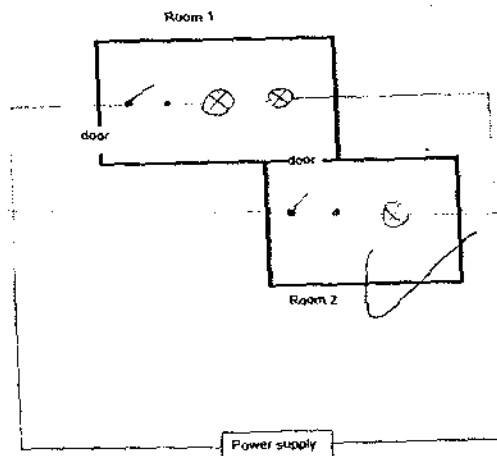

b)Use energy-saving light bulbs.

43)a)

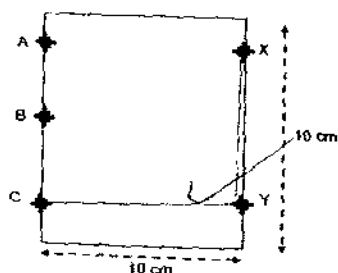

**b)i)The bulb would not light up.**

**ii)B and C is not connected, therefore, the circuit is broken and the bulb would not light up.**

**44)a)Material P is a better conductor of heat than material Q.**

**b)To ensure that his results are reliable.**

**c)Material P is a better conductor of heat than material Q.**

**d)It is fair experiment as we can check the distance of the nails A and B from the heat source is the same.**