

**SINGAPORE CHINESE GIRLS' SCHOOL
SECOND SEMESTRAL ASSESSMENT 2009
PRIMARY 5 SCIENCE**

Name: _____ () Date:

Class: Primary 5

**SCIENCE
BOOKLET A**

30 questions

60 marks

Total Time For Booklets A & B : 1 h 45 min

**DO NOT OPEN THIS BOOKLET UNTIL YOU ARE TOLD TO DO SO.
FOLLOW ALL INSTRUCTIONS CAREFULLY.**

3. Jack tested Materials A, B, C and D for their properties and made the following observations as shown in the table below.

Properties	A	B	C	D
Transparent	x	x	x	✓
Good conductor of heat	✓	x	x	x
Breaks easily when dropped	x	x	x	x
Melts easily	x	✓	x	x

Which of the materials is most suitable for making (handles) of cooking pots?

~~1) A only~~
~~2) C only~~

~~3) A and B only~~
~~4) C and D only~~

4. Xiaoming conducted an experiment and recorded his observations in the table below. Based on the data, what is/are the possible aim/s of the experiment?

Plant	Number of leaves on the plant	Amount of water in the beaker at the start of the experiment	Amount of water in the beaker at the end of the experiment
A	25	200ml	167ml
B	34	200ml	150ml
C	14	200ml	185ml
D	47	200ml	134ml

The aim of the experiment is/are to find out if the _____

- A: type of plant affects the amount of water taken in by the plant
 B: number of leaves on the plant affects the rate of evaporation of the water
 C: the amount of water in the beaker remains the same at the end of the experiment
 D: the number of leaves on the plant affect the amount of water taken in by the plant

1) B only
2) D only

3) A and C only
4) B, C and D only

5. Which of the following statements about our body systems are true?

- A: The digestive system absorbs digested food.
- B: The nose, gullet and lungs are parts of the respiratory system.
- C: The circulatory system transports digested food around our body.
- D: The respiratory system transports oxygen from the lungs to all parts of the body.

- ~~1) A and C only~~
- ~~2) B and D only~~
- ~~3) A, B and C only~~
- ~~4) A, C and D only~~

6. Gopal set up an experiment as shown below.

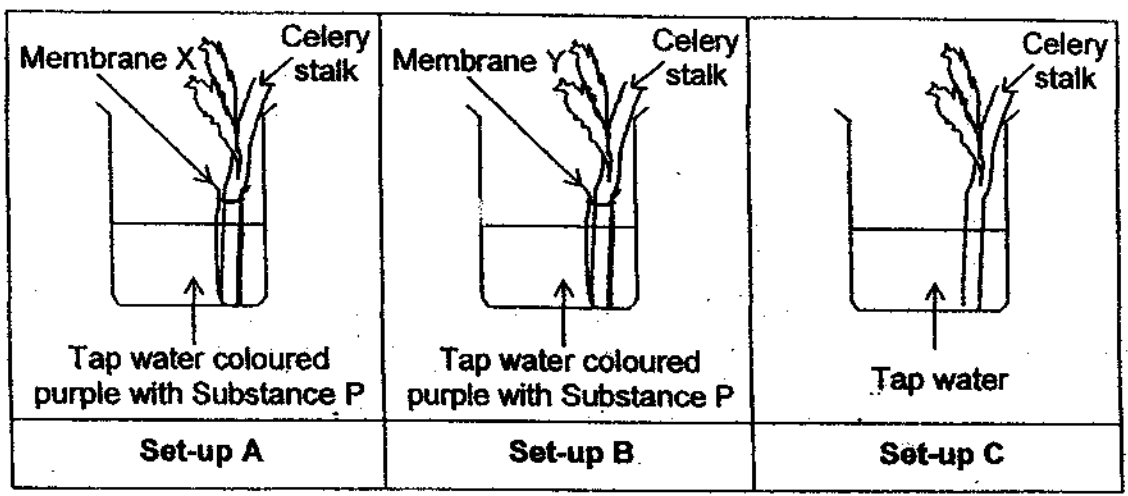

The base of the celery stalks in Set-up A and B are wrapped with Membrane X and Y respectively before placing them into the beaker of tap water that has been coloured purple with Substance P. The celery stalk in Set-up C was placed in tap water. 3 days later, Gopal noted his observations of the 3 celery stalks in the table below.

	Set-up A	Set-up B	Set-up C
Observations	Leaves are green and firm	Leaves are yellowish and floppy	Leaves are green and firm

Which of the following statement/s can be concluded from Gopal's experiment?

- A: Water can pass through Membrane X.
- B: Substance P can pass through Membrane X but not Membrane Y.
- C: Substance P in Set-up B prevented the celery stalk from taking in water.
- D: The leaves of the celery stalk in Set-up B will be firm if the base of the celery stalk was not wrapped with Membrane Y.

- ~~1) A only~~
- ~~2) A and D only~~
- ~~3) B, C and D only~~
- ~~4) A, C and D only~~

7. Study the electric circuit below and determine how wires P and Q could be connected. Which of the connections allow the bulb to light up?

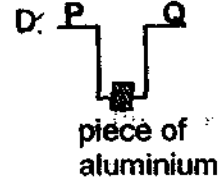
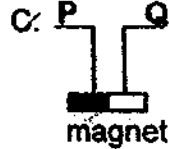
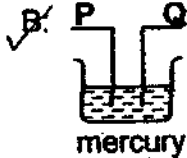
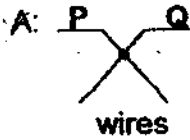
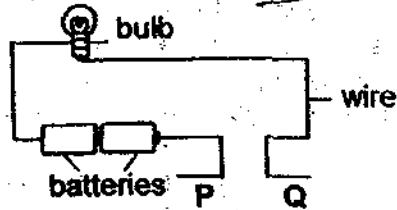

- ~~1~~ A and D only
~~2~~ C and D only

- ~~3~~ A, B and D only
~~4~~ A, B, C and D

8. Study the flowchart below.

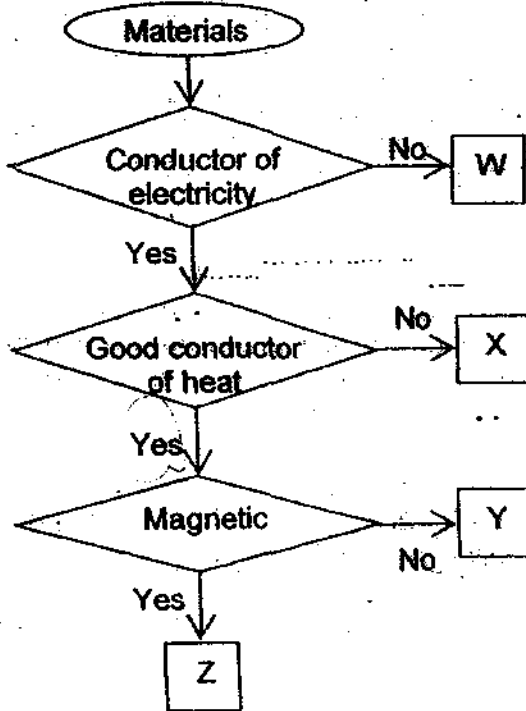

Based on the flowchart above, which of the following statements are definitely true?

- A: W cannot conduct electricity.
 B: Y is a good conductor of heat but is non-magnetic.
 C: Z is magnetic but is a non-conductor of electricity.
 D: X is a poor conductor of heat but is a conductor of electricity.

- ~~1~~ A only
~~2~~ A and B only

- ~~3~~ C and D only
~~4~~ A, B and D only

9. Minah wants to find out which of her 2 magnets has a stronger magnetic strength. Which of the following pair/s of set-up/s should she use in order to carry out a fair test?

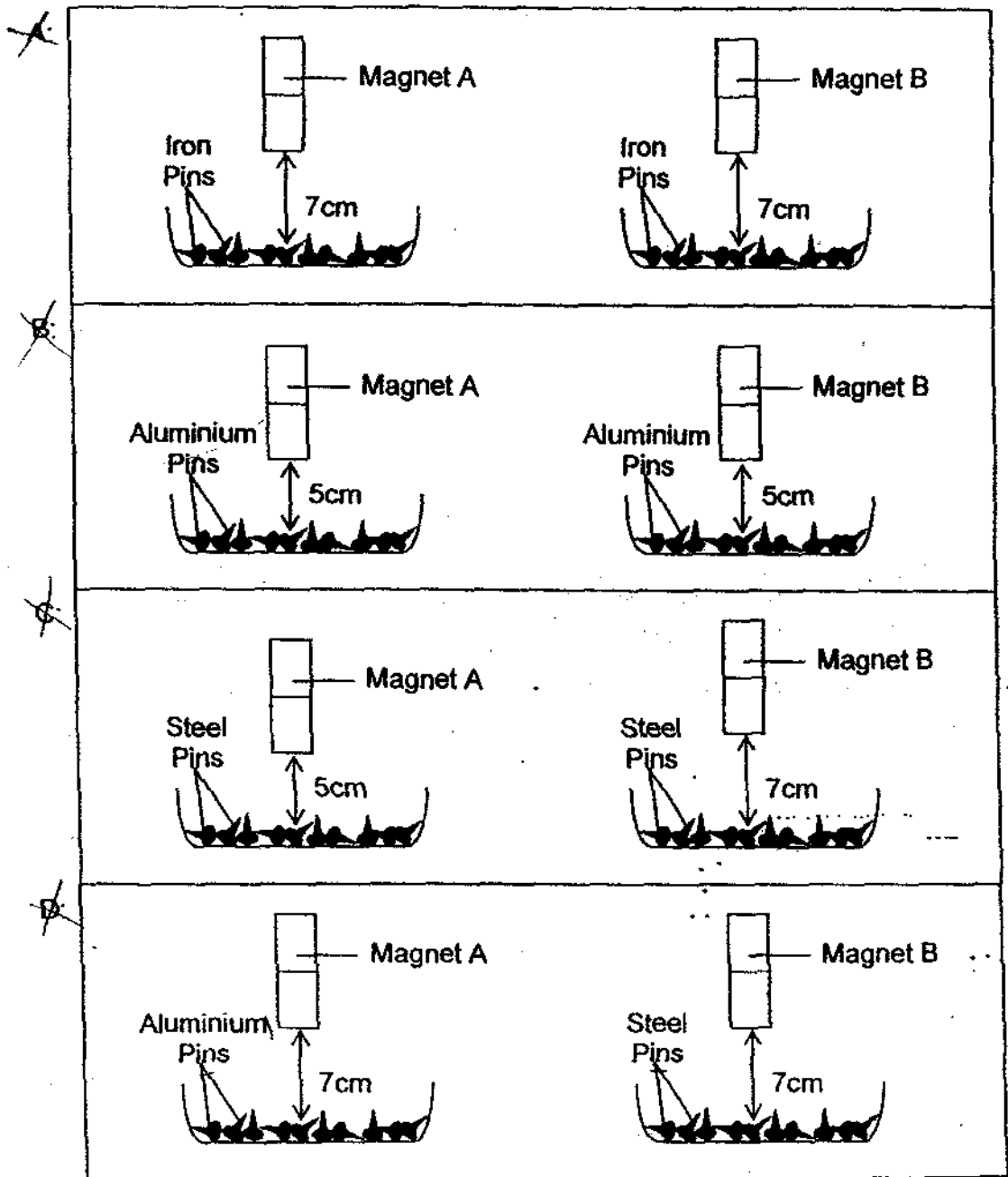

- ~~1) A only~~
 2) A and B only

- ~~3) C and D only~~
 4) A, B and D only

10. Study the circuits below.

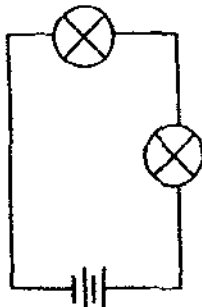

Circuit A

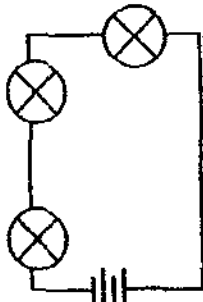

Circuit B

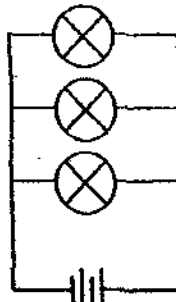

Circuit C

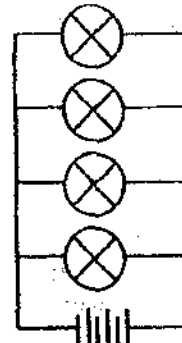

Circuit D

Arrange the circuits in order from the one with the brightest bulbs to the circuit with the least bright bulbs. (Bulbs and batteries in all the circuits are similar)

- 1) A, C, D, B
- 2) B, C, A, D

- 3) C, B, A, D
- 4) D, C, A, B

11. The diagram below shows an electromagnet. The magnet can only attract 2 pins. What can be done to increase the number of pins that the magnets can attract?

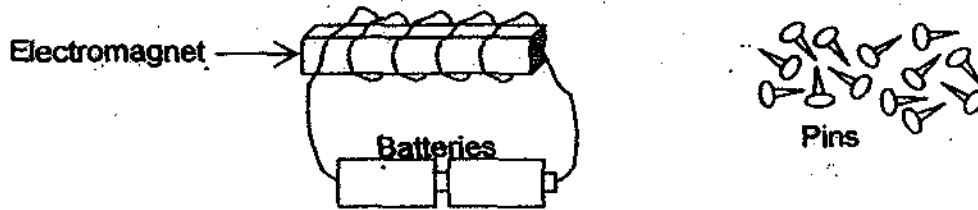

- A: Add more batteries to the circuit.
- B: Increase the number of pins available.
- C: Move the electromagnet closer to the pins.
- D: Increase the number of coils of the wire around the electromagnet.

- ~~1) A and D only~~
- ~~2) B and C only~~

- ~~3) A, C and D only~~
- ~~4) A, B, C and D~~

12. Which of the following statements about heat and temperature is/are correct.

- A: Heat is a form of energy.
- B: Heat is a measure of how hot something is.
- C: Heat travels from a hotter place to a cooler place.
- D: An object has an increase in temperature because it has lost its coldness.

- ~~1) A and C only~~
- ~~2) B and D only~~

- ~~3) A, B and C only~~
- ~~4) A, B, C and D~~

13. Betty wants to find out if the colour or the (type of surface) has a larger impact on the amount of heat absorbed by an object. Which of the following containers should she use to conduct her experiment?

Containers	Colour	Material	Surface
A	Pink	Iron	Shiny
B	Black	Aluminium	Matte
C	Red	Copper	Matte
D	Dark brown	Copper	Shiny
E	Pink	Iron	Matte
F	Dark brown	Iron	Matte
G	Black	Copper	Shiny
H	Red	Aluminium	Shiny

~~1) A, E and F~~
~~2) B, G and H~~

~~3) C, D and E~~
~~4) D, F and G~~

14. Mr Lim placed Material W, X, Y and Z in between 2 glass containers and poured water at 98°C into each of the inner glass containers. He then measured the temperature of water after 40 minutes. The temperature of water in each set-up at the end of the experiment are shown in the diagrams below.

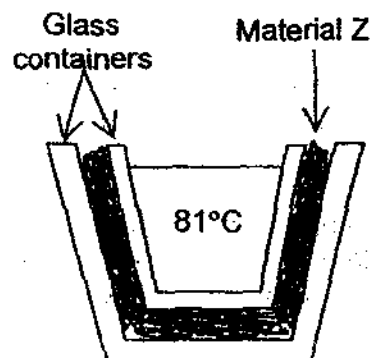
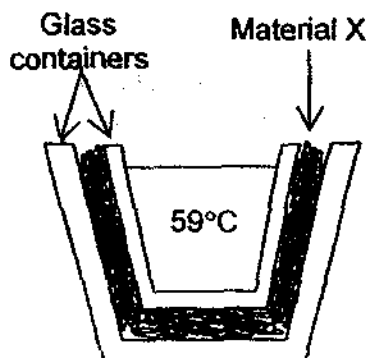
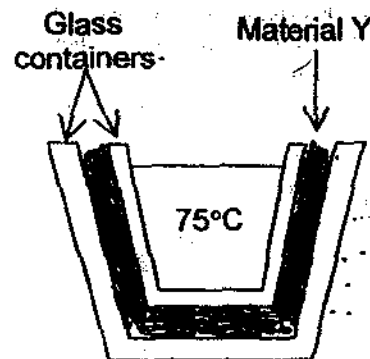
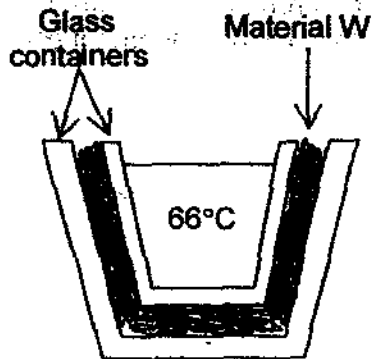

Which material should he use to make an ice container to prevent the ice from melting quickly?

1) W
 2) X

3) Y
 4) Z

15. In each of the set-ups below, the temperature of the water at the start of the experiment was 25°C.

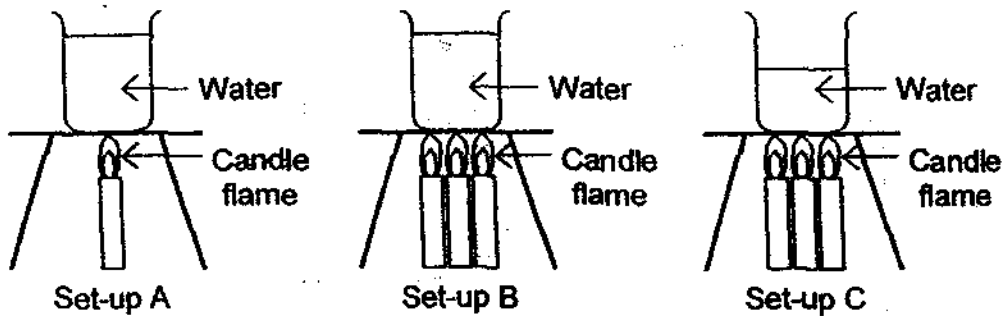

What is the most likely temperature of water in each set-up after 5 minutes?

	Set-up A	Set-up B	Set-up C
1)	47°C	65°C	88°C
2)	61°C	87°C	43°C
3)	90°C	56°C	37°C
4)	45°C	84°C	79°C

16. Samuel attached a rod made of Material P to a rod made of Material Q as shown. He wrapped a piece of cloth over both rods and heated it over a flame for 8 minutes.

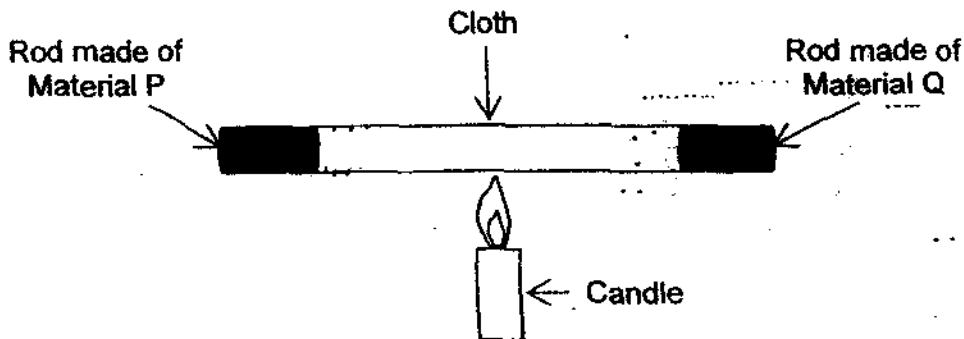

He noticed that only the part of cloth that has been wrapped over the rod made of Material P is scorched. Which of the conclusions can he make from his experiment?

- A: Material P is a poor conductor of heat.
- B: Material P is a good conductor of heat.
- C: Material Q is a poor conductor of heat.
- D: Material Q is a good conductor of heat.

~~X~~ A only
~~X~~ B only

~~X~~ B and C only
~~X~~ A and D only

17. Which of the following graphs correctly shows the rate of photosynthesis and the intensity of light?

1) Rate of photosynthesis

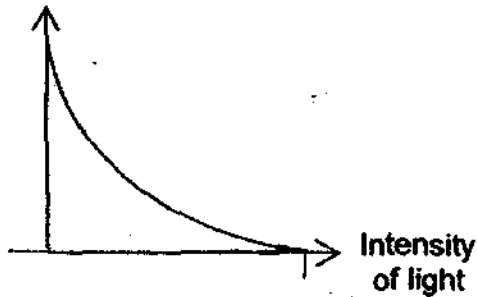

3) Rate of photosynthesis

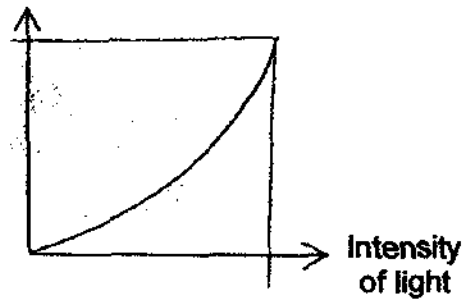

2) Rate of photosynthesis

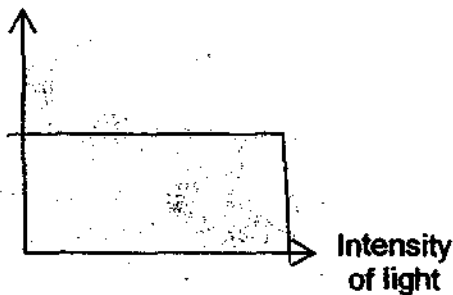

4) Rate of photosynthesis

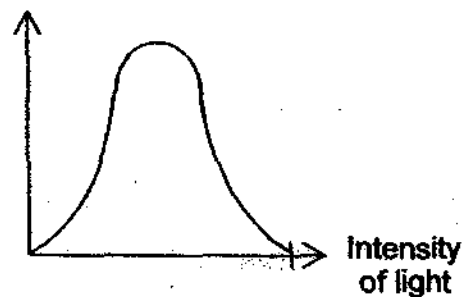

18. Aminah placed some Water Plant X under certain conditions. She used a device to collect the gas given out by Water Plant X and pumped it into a test-tube of lime water. The limewater did not turn chalky. What can be deduced from Aminah's experiment?

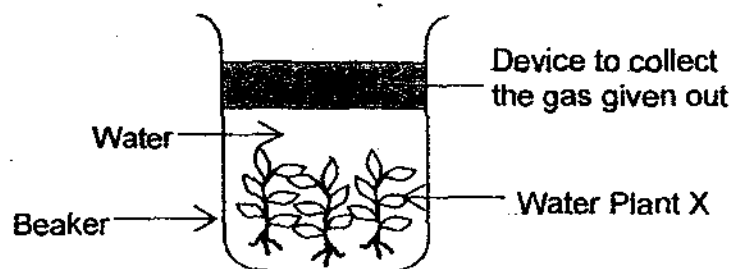

- A: Water Plant X was placed under light.
- B: Water Plant X did not carry out photosynthesis.
- C: Aminah conducted the experiment in the morning.
- D: The water in the beaker has dissolved gases at the start of the experiment.

~~1) A and D only~~
~~2) B and C only~~

~~3) A, B and C only~~
~~4) A, C and D only~~

19. For some plants, not all parts of the leaf contain chlorophyll. The leaf below has been tested for starch and the parts that have been shaded shows that the iodine on the leaf has turned dark blue.

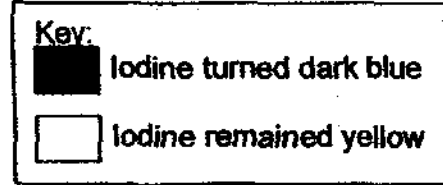

Which one of the following leaves correctly shows the shaded parts of the leaf that contains chlorophyll?

1)



3)



2)

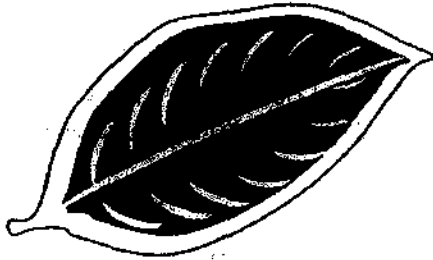

4)

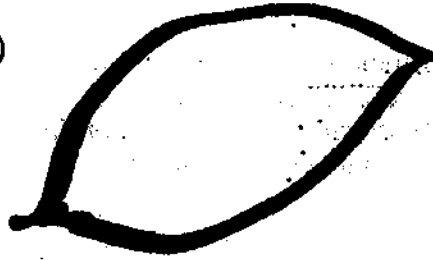

20. James had 4 pieces of paper of different shapes and made of different materials as shown below.

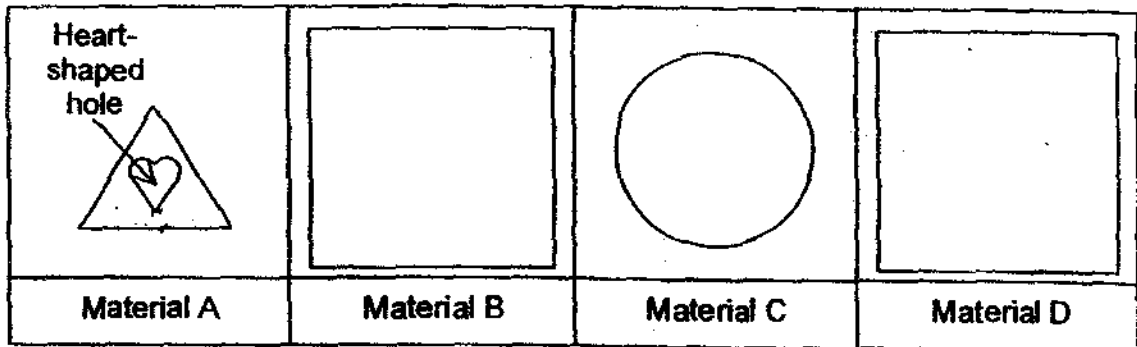

He placed the 4 different materials one in front of the other as shown in the diagram below.

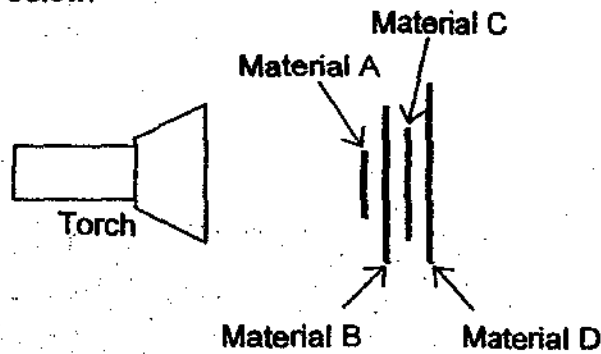

James then recorded his observations on Material C and D as shown below.

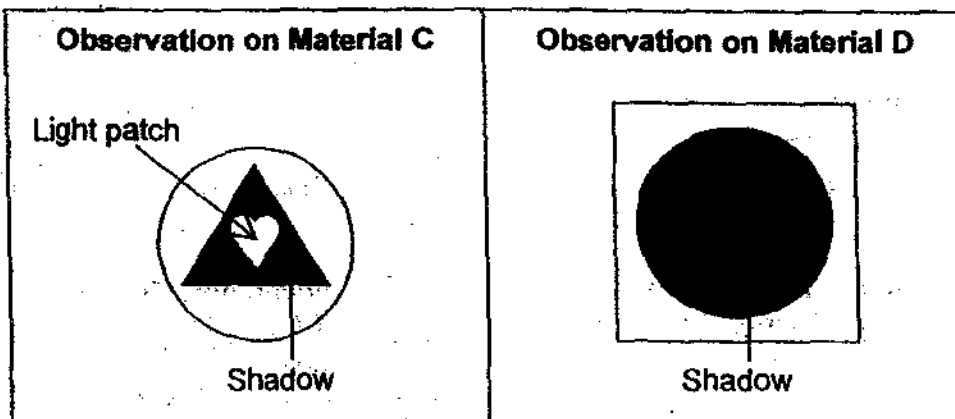

Which of the following shows the degree of transparency of Material A, B, C and D respectively?

	Material A	Material B	Material C	Material D
1)	Transparent	Transparent	Opaque	Opaque
2)	Opaque	Opaque	Opaque	Transparent
3)	Opaque	Transparent	Opaque	Opaque
4)	Opaque	Transparent	Transparent	Opaque

21. The diagram below shows the development of a plant.

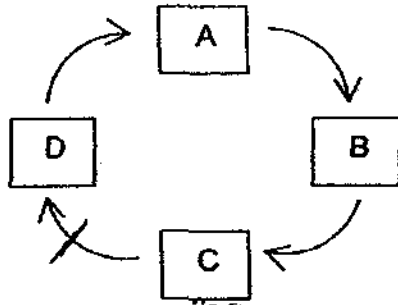

If Stage A stands for germination, between which 2 stages will the fruit and seed start to develop?

- 1) Between Stages A and B
- 2) Between Stages B and C
- 3) Between Stages C and D
- 4) Between Stages D and A

22. The diagrams below show the life cycles of Animal X, Animal Y and Animal Z.

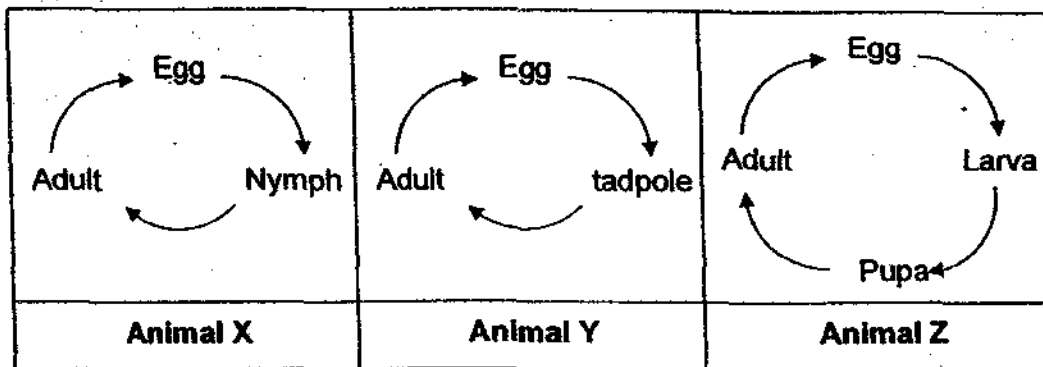

Which of the following similarities and differences of the life cycles above is/are true?

A	Similarities between the life cycles of Animal X and Animal Y	Differences between the life cycles of Animal Y and Animal Z
B	Both have 3 stages in their life cycles.	Animal Y has 3 stages in its life cycle but Animal Z has 4 stages.
C	Both lay eggs in water.	Animal Y lays eggs in water but Animal Z does not.
D	Both their young look like their respective adults.	The young of Animal Y look like its adult but the young of Animal Z does not.

- ~~1) A only~~
- ~~2) A and B only~~

- ~~3) B and C only~~
- ~~4) A, B and C~~

23. The diagram below shows the human reproductive system.

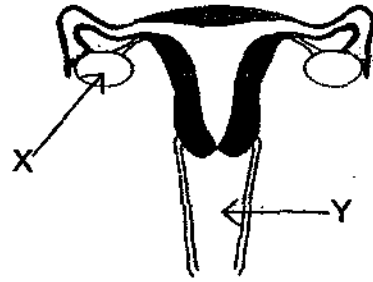

Which of the following correctly indicates parts X and Y respectively?

	X	Y
1)	Ovary	Womb
2)	Testes	Penis
3)	Ovary	Vagina
4)	Penis	Testes

24. The diagram below shows the family tree of Mr Tan.

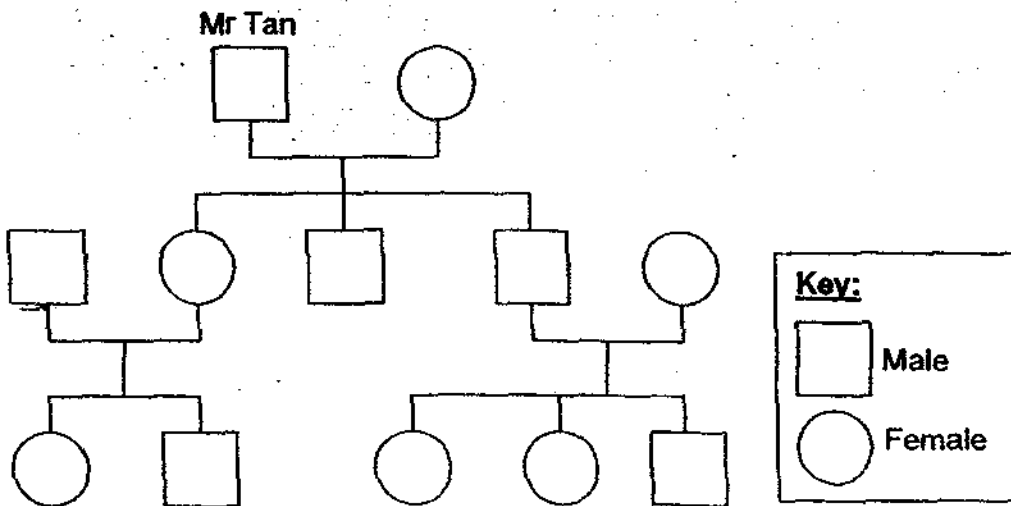

How many granddaughters does Mr Tan have?

- 1) 5
- 2) 2
- 3) 3
- 4) 4

25. Shuhui made some observations of Substance P, Q, R and S in the table below.

Substances	Definite shape	Can be compressed
P	Yes	No
Q	No	No
R	No	Yes
S	Yes	No

Which of the following statements can be concluded from her findings?

- A: Substance R is a gas.
 B: Substance Q is a liquid.
 C: Substance P and S are solids.

- D: Substance Q has no definite volume.
 E: Substance P, Q, R and S have mass.

- ~~1) A and B only~~
~~2) C and D only~~

- ~~3) B, C and D only~~
~~4) A, B, C and E only~~

26. Meiling filled a syringe with 10ml of air and 10ml of water. She placed her thumb over the nozzle and plunged in the plunger.

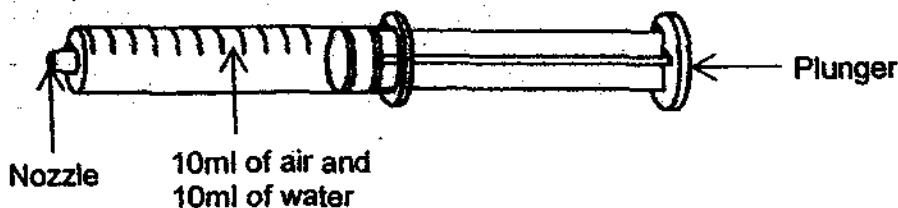

What is the most likely total volume of air and water in the syringe after Meiling has plunged in the plunger?

- 1) 6ml
 2) 10ml
 3) 13ml
 4) 20ml
27. When 100g of Material X is placed into a tank of water, the water level rose up to the level marked 'A' as shown in the diagram below.

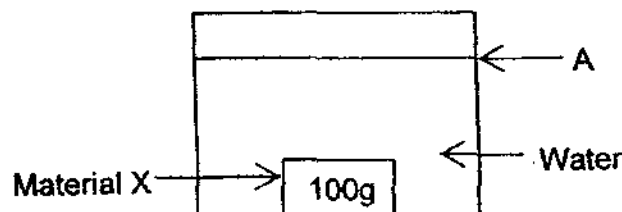

When the 100g of Material X is removed and replaced with 200g of Material Y, what will happen to the water level in the tank?

- 1) The water level will be above 'A'.
 2) The water level will remain at 'A'.
 3) The water level will be lower than 'A'.
 4) It is not possible to tell without doing the experiment.

28. 4 different liquids at 25°C are placed in a trough containing water at 95°C. 4 similar thermometers are placed into the liquids and their temperatures were observed after 10 minutes as shown in the diagram below.

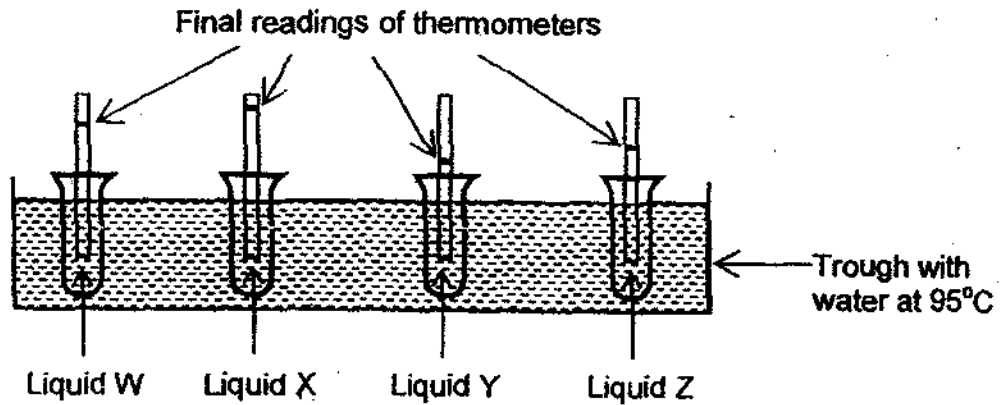

Which of the following conclusions can be made from the experiment?

- A: Liquid W is a better conductor of heat than Liquid X.
 B: Liquid X is a better conductor of heat than Liquid Y.
 C: Liquid Y is a poorer conductor of heat than Liquid Z.
 D: Liquid Z is a poorer conductor of heat than Liquid W.

~~1) A and B only~~
~~2) C and D only~~

~~3) B, C and D only~~
~~4) A, B, C and D~~

29. Linda wants to find out if the exposed surface area of the water will affect its rate of evaporation. Each of the container below contains 100ml of water. Which pair of containers will be the best choice for Linda to conduct her experiment?

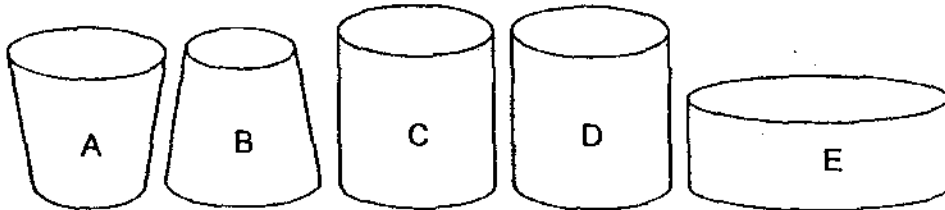

~~1) A and B~~
~~2) B and C~~

~~3) C and D~~
~~4) D and E~~

30. Study the set-ups of an experiment as shown below.

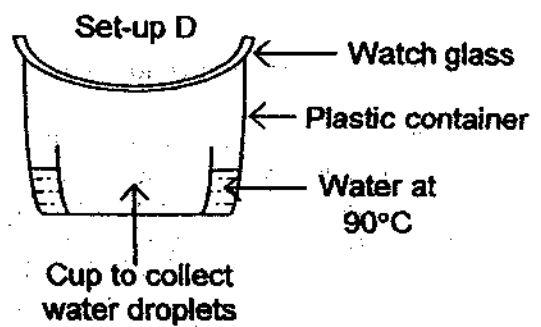
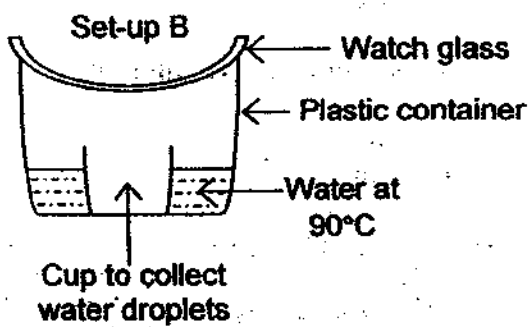
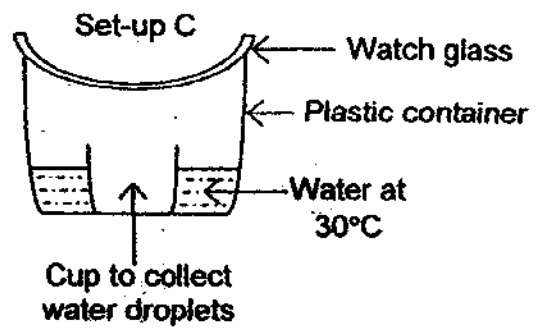
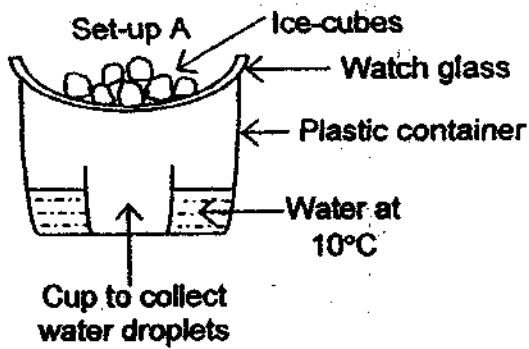

If the room temperature is 30°C, in which set-up will there be the most amount of water in the cup at the end of 15 minutes?

~~1) A~~
2) B

~~3) C~~
4) D

**SINGAPORE CHINESE GIRLS' SCHOOL
SECOND SEMESTRAL ASSESSMENT 2009
PRIMARY 5 SCIENCE**

Name: _____ () Date: _____

Class: Primary 5

Components	Marks Obtained	Total Marks
Booklet A		60
Booklet B		40
Total		100

Parent's Signature

**SCIENCE
BOOKLET B**

16 questions

40 marks

Total Time For Booklets A & B : 1 h 45 min

DO NOT OPEN THIS BOOKLET UNTIL YOU ARE TOLD TO DO SO.

FOLLOW ALL INSTRUCTIONS CAREFULLY

Name: _____ ()
Class: Primary 5

Part II (40 marks)

Answer all the following questions.

31. Study the classification chart below. Write down a suitable heading for each of the boxes. (2m)

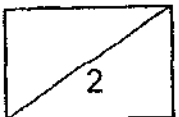
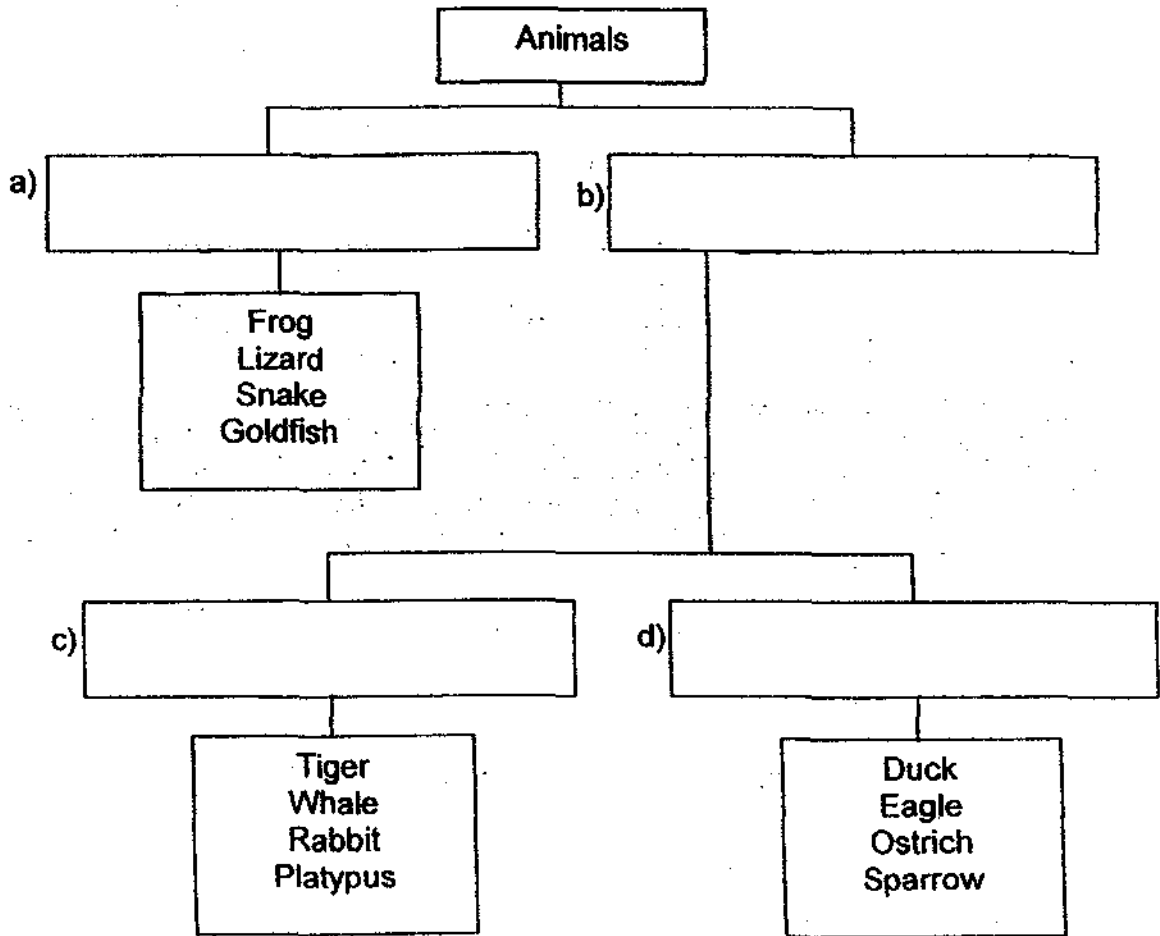

32. Lynn conducted an experiment to find out the rate of reproduction of different organisms at different temperatures.

Temperature	Number of Organism X				
	0 min	2 min	4 min	6 min	8 min
10°C	10	10	10	10	10
25°C	10	18	31	49	66
40°C	10	25	48	70	102
55°C	10	10	14	14	27
70°C	10	10	10	10	10
85°C	10	10	10	10	10

Temperature	Number of Organism Y				
	0 min	2 min	4 min	6 min	8 min
10°C	10	10	10	10	10
25°C	10	10	10	15	15
40°C	10	29	58	86	108
55°C	10	38	64	98	136
70°C	10	20	38	62	97
85°C	10	10	10	10	10

Temperature	Number of Organism Z				
	0 min	2 min	4 min	6 min	8 min
10°C	10	17	34	48	56
25°C	10	23	42	67	89
40°C	10	45	89	121	156
55°C	10	33	56	87	106
70°C	10	25	54	71	88
85°C	10	10	10	10	10

- a) Why did Lynn use 10 organisms at the start of the experiment instead of 1? (1m)

- b) Which organism reproduced the fastest at 55°C? (1m)

- c) Which organism can reproduce in the widest range of temperature? (1m)

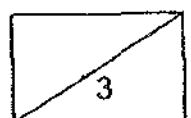

33. The diagram below shows the human cheek cell.

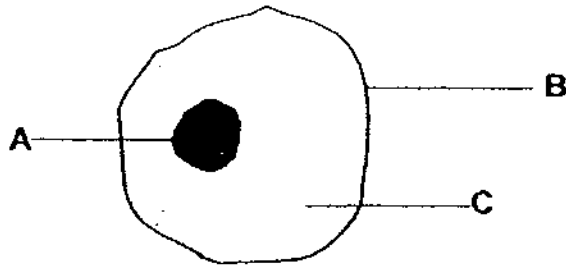

- a) Which part, A, B or C controls the activities in the cell? (½m)
-
- b) Which part, A, B or C controls the substances that can pass in or out of the cell? (½m)
-
- c) Name 2 parts of a plant cell that cannot be found in an animal cell. (1m)
-

34. The diagram below shows human circulatory system.

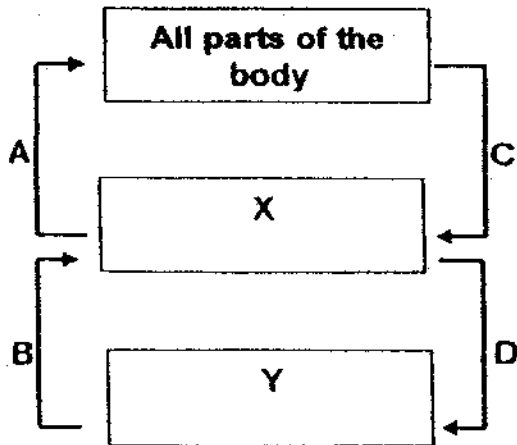

- a) What parts do X and Y represent respectively? (1m)
- X: _____
- Y: _____
- c) Which arrow/s represent/s blood rich in oxygen? (1m)
-

35. Mary used a circuit tester to test a circuit card and tabulated the results in a table as shown below.

Clips tested	Did the bulb light up?
A and B	No
A and E	No
A and F	No
B and C	Yes
C and E	No
D and F	No
E and F	No

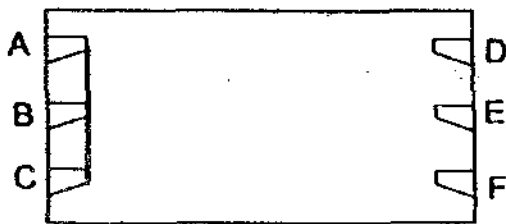

Circuit Card P

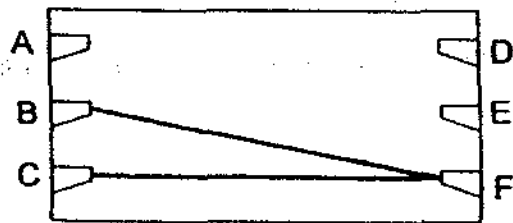

Circuit Card S

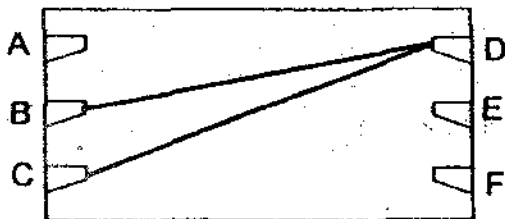

Circuit Card T

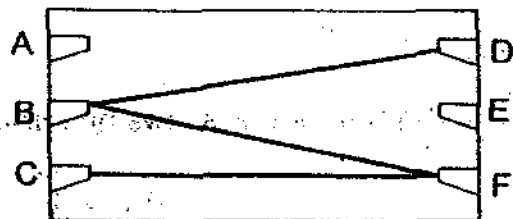

Circuit Card Q

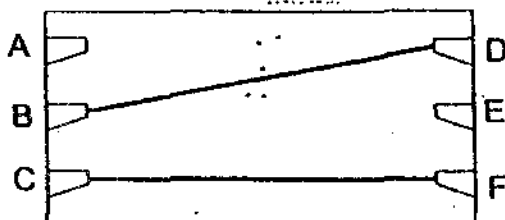

Circuit Card R

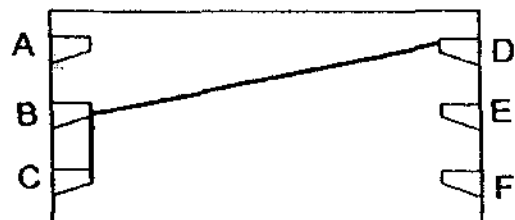

Circuit Card U

- a) Which of the following circuit card/s could she have tested? (2m)
-
- b) What could Mary have done to identify the connections in the circuit card more accurately? (1m)
-
- c) Which 2 cards will have exactly the same results when tested with a circuit tester? (1m)
-

36. Study the circuit diagrams below.

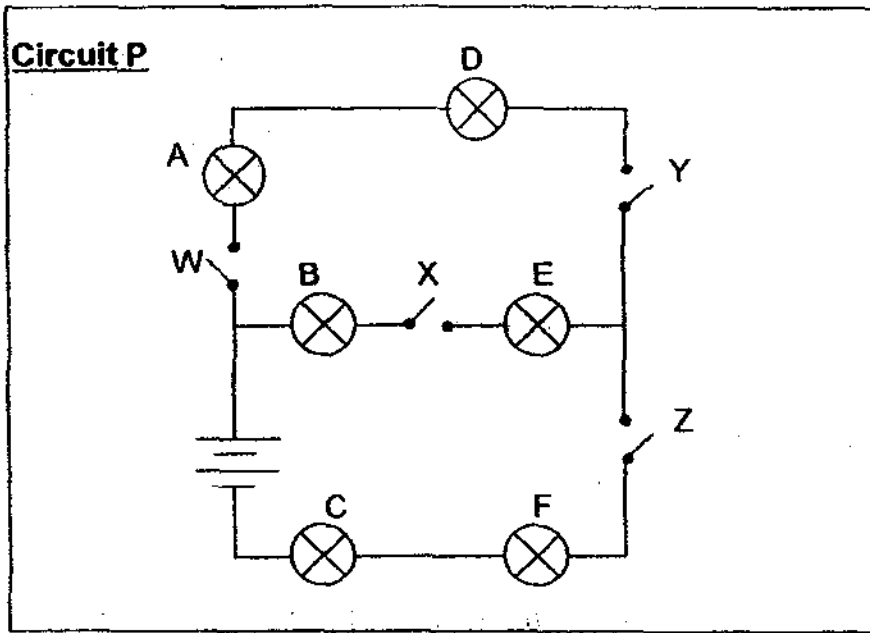

- a) If all the switches in Circuit P are closed and Bulb A is fused, how many bulbs will light up? (1m)
-
- b) If Switch W and Switch X are closed in Circuit P and Switch Y and Switch Z are open, how many bulbs will light up? (1m)
-
- c) Which switch when open, will not allow any bulb to light up? (1m)
-
- d) In Circuit Q below, mark an 'X' on the circuit to indicate where you would place a switch such that the switch will be able to control all the bulbs. (1m)

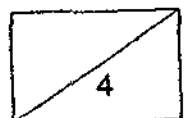
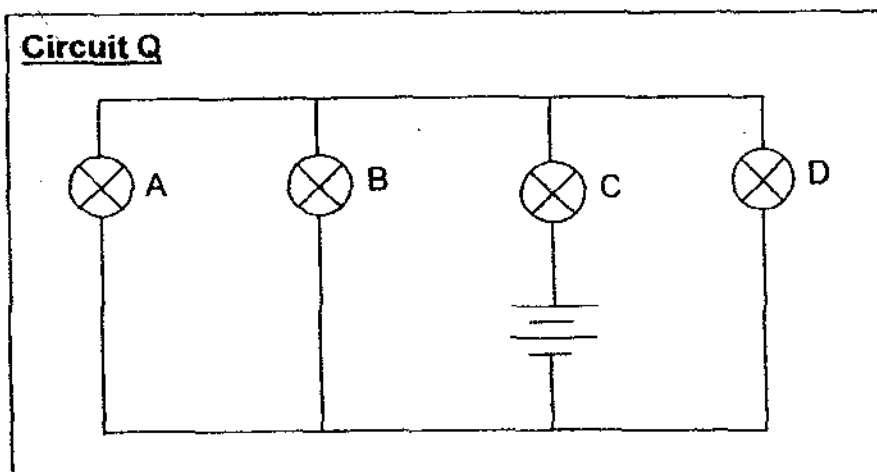

37a. For each of the scenarios, indicate if the bulbs/electrical devices should be connected in series or in parallel. (3m)

Scenarios	Should the bulbs/ electrical devices be connected in series or in parallel?
i) Electrical devices in a house that can be controlled independently.	
ii) Oven connected to a fuse to prevent overheating.	
iii) Toy car that comes with 3-way switch that allows the child to turn on either the blue light or the red light.	

b. Mr Lim wants to be able to switch on a lamp when he is either at the top of the stairs or at the bottom of the stairs.

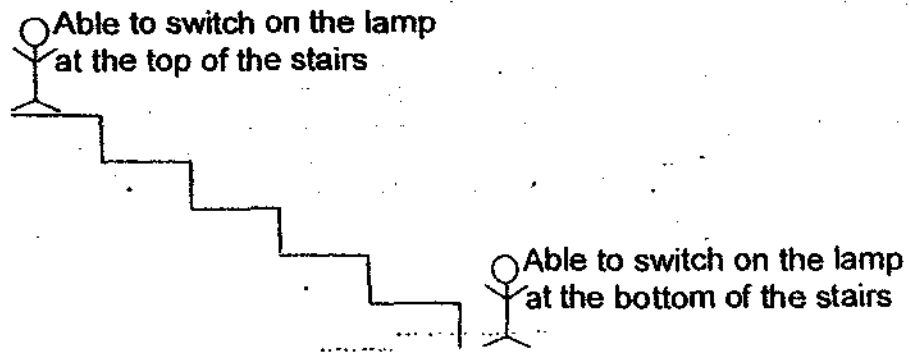

Put a tick (✓) in the correct box below to indicate the circuit diagram that correctly shows the connection of Mr Lim's lamp. (1m)

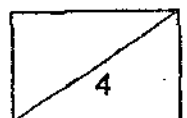
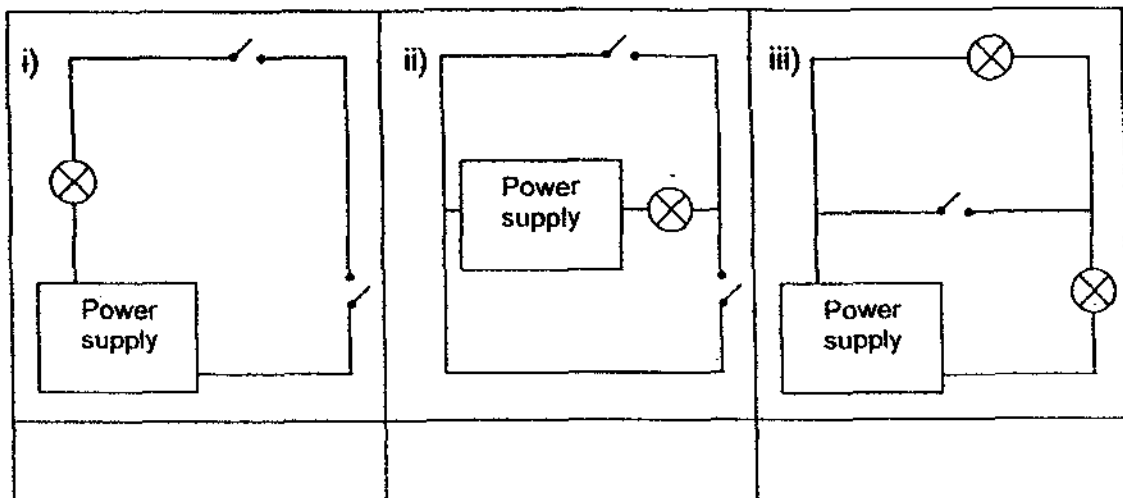

38. Minghua wanted to find out the degree of transparency of Materials P, Q, R and S. He set up his experiment as shown below.

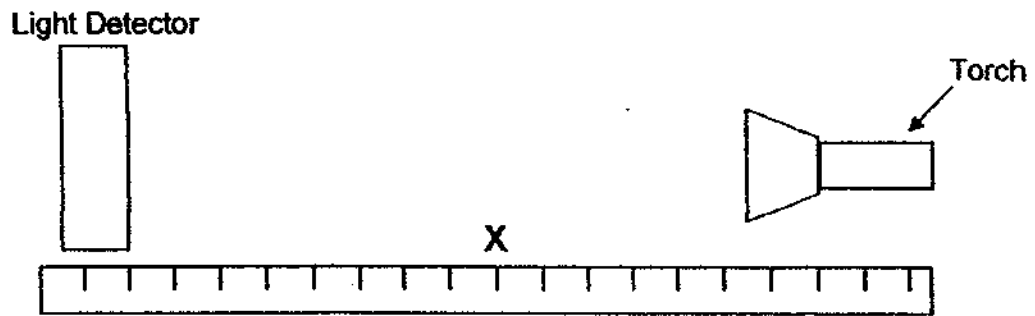

Each material was placed at Position X and the amount of light detected by the light detector was recorded in the table below.

Type of Material	Amount of light detected (Lux)
P	550
Q	320
R	600
S	240

Draw and label a bar graph using the data of Minghua's experiment. Arrange the materials starting with the one that is the most translucent to the material that is the least translucent. (2m)

Degree of Transparency

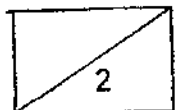
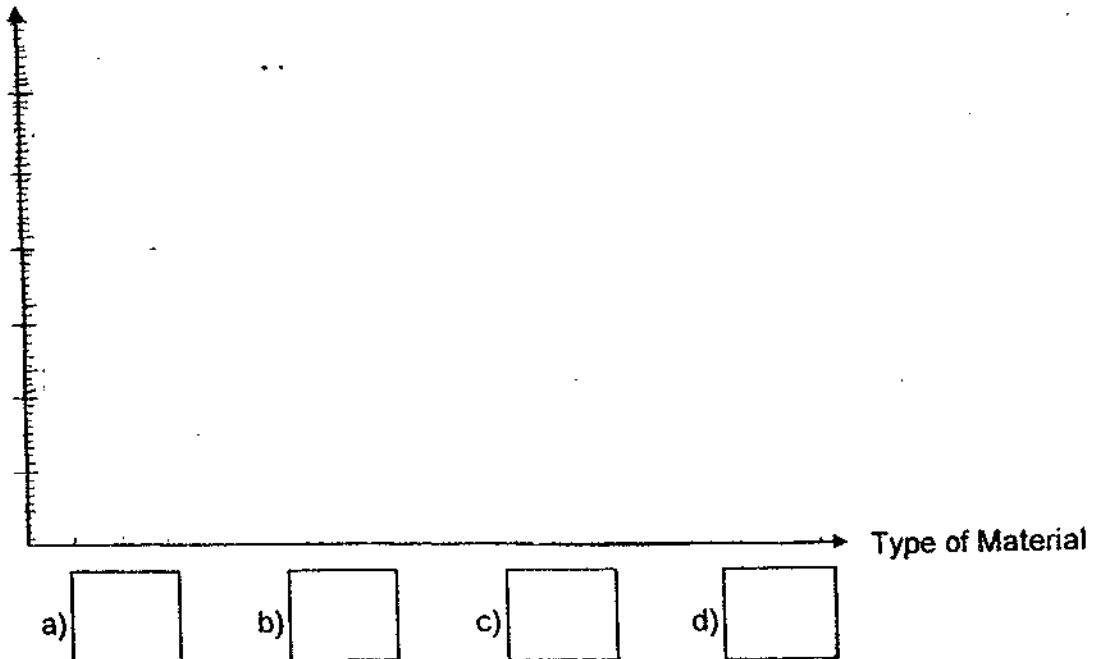

39. In the diagram below, add in 2 arrows to indicate the exchange of gases during photosynthesis. (2m)

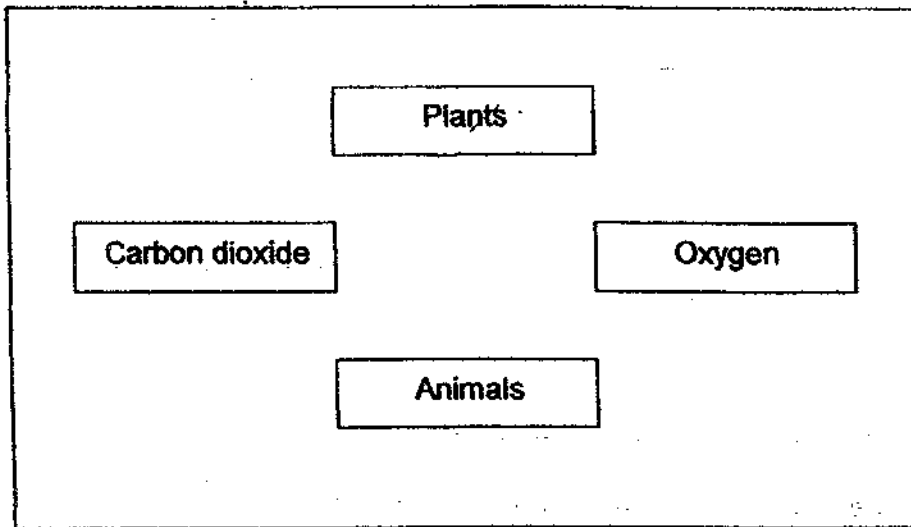

40. Aminah conducted an experiment using different materials to cover ice blocks.

	Covered with Material X	Covered with Material Y	Covered with Material Z
Time taken for ice block to melt	72 minutes	55 minutes	48 minutes

- a) What was the aim of Aminah's experiment? (1m) _____
- b) Name 2 variables that must be kept the same to conduct a fair test. (1m)
- c) Which material, X, Y or Z do you think is the most suitable for making the base of a cooking pot? Give a reason for your answer. (1m)

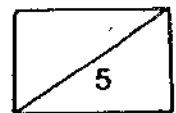

41. Sam carried out an experiment as shown below.

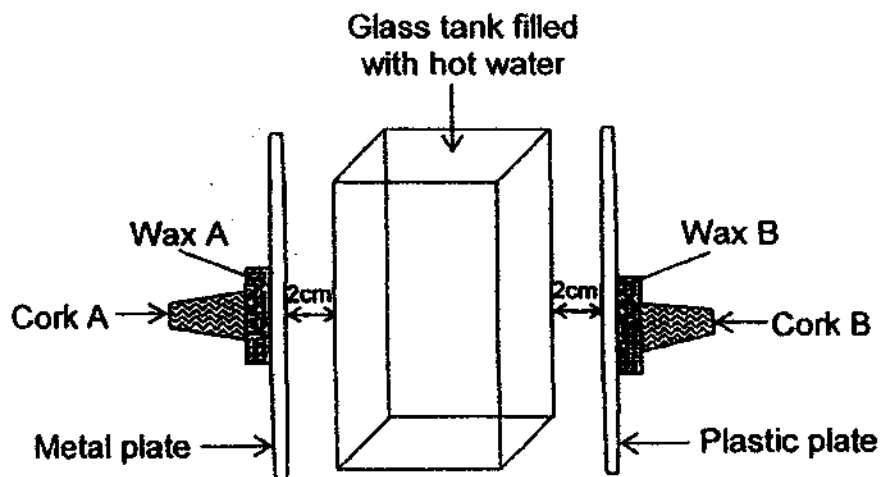

If he kept all the controlled variables the same, which cork would fall off first? Give a reason for your answer. (2m)

42. The diagram below shows the water cycle.

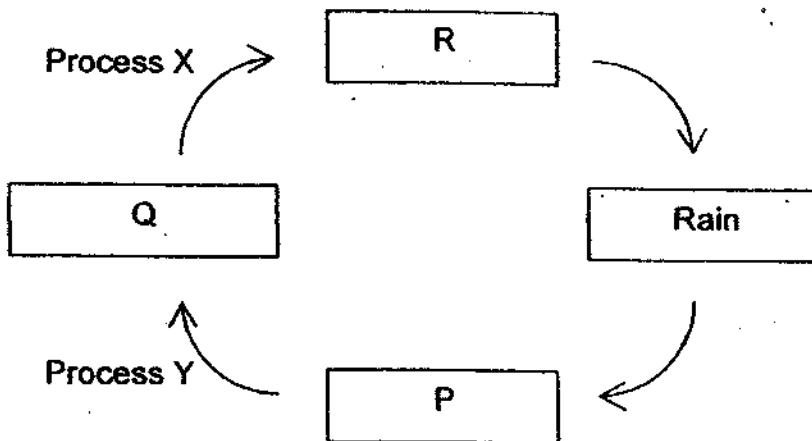

a) Name Process X and Process Y. (1m)

Process X: _____

Process Y: _____

b) In the table below, put a tick (✓) in the appropriate column to indicate if there is heat gain or heat loss in the water when it goes through Process X and Process Y. (1m)

	Process	Heat gain	Heat loss
i)	X		
ii)	Y		

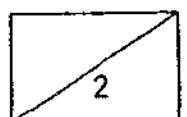

43a. Observe the diagram of the cross-section of the flower below.

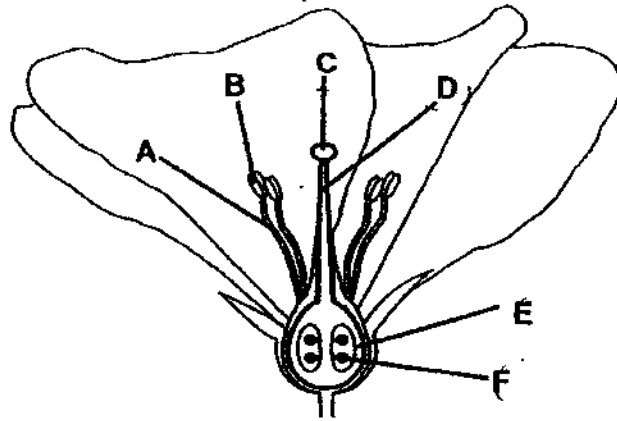

Classify parts A, B, C, D, E and F in the classification chart below. (3m)

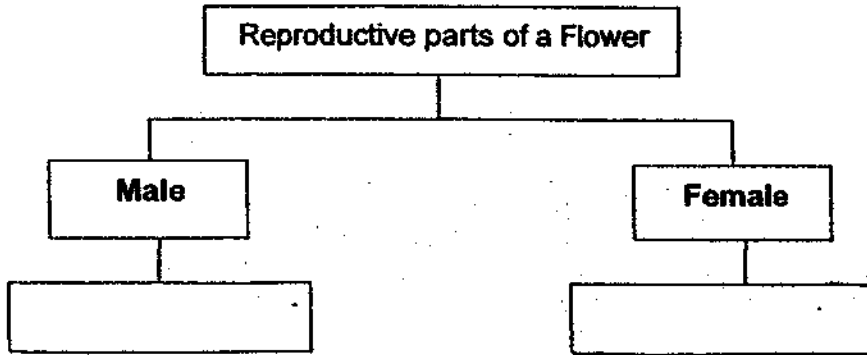

b) Tim said that Part F will develop into a fruit after fertilisation has taken place. Do you agree with him? Give a reason for your answer. (1m)

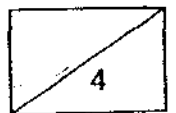

44. Study the diagrams of the fruits below.

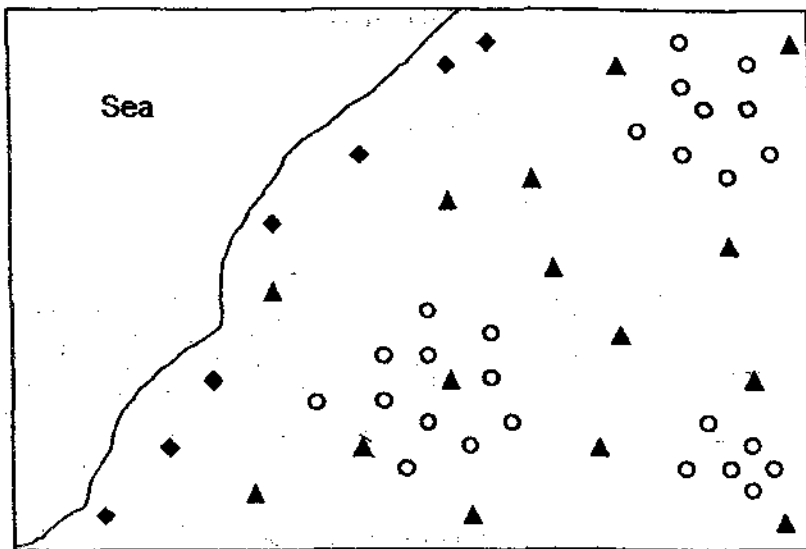
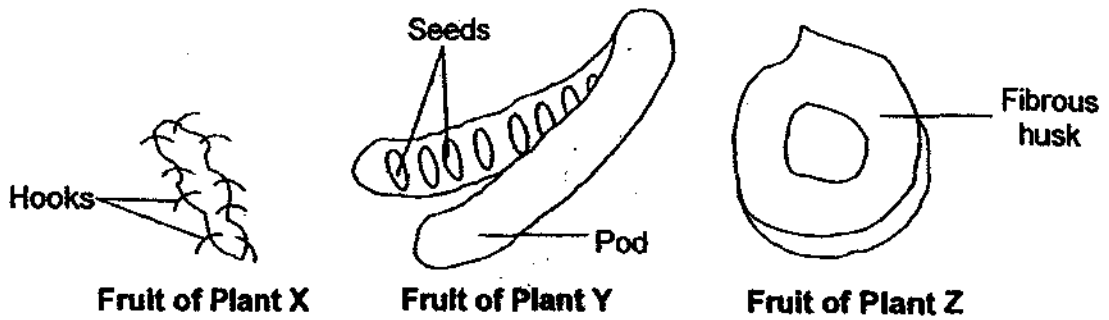

The map above shows the distribution of the Plants X, Y and Z.

a) Which of the following symbols represent Plants X, Y and Z respectively? (1½m)

i) ◆ : _____

ii) ▲ : _____

iii) ○ : _____

b) How does having a fibrous husk help Fruit Z in its dispersal? (½m)

c) Explain how the dispersal of the fruit and seed of Plant X is different from the dispersal of the papaya seeds. (2m)

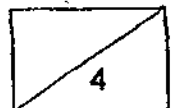

ANSWER SHEET

EXAM PAPER 2009

SCHOOL : SCGS PRIMARY
SUBJECT : PRIMARY 5 SCIENCE

TERM : SA2

Q1	Q2	Q3	Q4	Q5	Q6	Q7	Q8	Q9	Q10	Q11	Q12	Q13	Q14	Q15	Q16	Q17
1	3	4	2	1	2	4	4	1	4	3	1	1	4	1	4	3

Q18	Q19	Q20	Q21	Q22	Q23	Q24	Q25	Q26	Q27	Q28	Q29	Q30
1	2	3	3	1	3	3	4	3	4	3	4	2

31)a)cold-blooded b)warm-blooded c)mammals d)birds

32)a)To ensure accuracy of the results.

b)Organism Y.

c)Organism Z.

33)a)Part A.

b)Part B.

c)Cell wall and chloroplast.

34)a)X: heart Y: lungs

b)Arrows A and B.

35)a)Circuit cards S, T and U.

b)Test more pairs of clips.

c)Cards T and U.

36)a)4 bulbs.

b)0 bulbs.

c)Switch Z.

d)

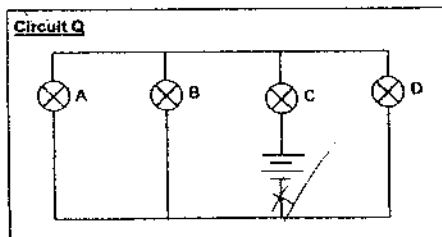

37)a)i)Parallel ii)Series iii)Parallel
 b)ii)

38)a)

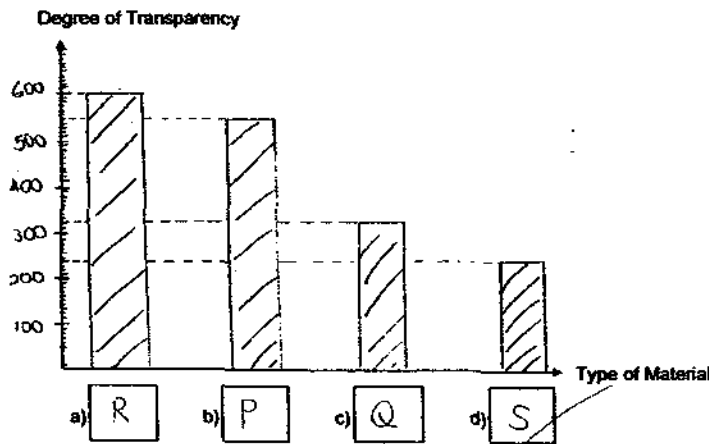

39)

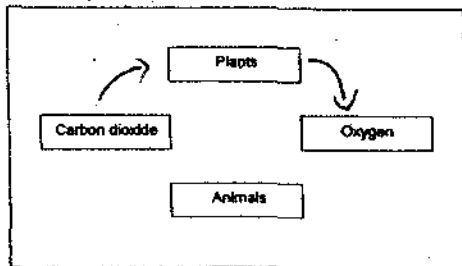

40)a)It was to find out whether material X, Y or Z are better insulators of heat.

b)They are the size of the ice blocks and the place where the ice block were placed.

c)Material Z is the most suitable for making the base of a cooking pot. Material Z is the best conductor of heat among the three materials and heat the fastest.

41)A. Metal is a better conductor of heat than plastic, so it will conductor heat to Wax A faster.

42)a)X: condensation Y: Evaporation

b)i)Heat loss ii)Heat gain

43)a)Male: A, B Female: C,D,E,F

b)No, I do not agree with him. Part F is the ovule of the flower and will develop into a seed and not a fruit after fertilization has taken place.

44)a)i)Plant Z

ii)Plant X

iii)Plant Y

b)It has air in it and allows the seed to float on water.

c)The hooks of plant X cling onto the animals fur, while the papaya seeds are eaten by animals and excreted.