



**RAFFLES GIRLS' PRIMARY SCHOOL**  
**SEMESTRAL ASSESSMENT 2**

**2009**

Name : \_\_\_\_\_ Index No: \_\_\_\_\_ Class: P3 \_\_\_\_\_

**30<sup>th</sup> October 2009**      **SCIENCE**      Att: 1 h 15 min

Section A	48	
Section B	32	
Your score out of 80 marks		
Highest score	Class	Level
Average score		
Parent's signature		

**SECTION A (24 x 2 marks)**

For each question from 1 to 24, four options are given.  
 One of them is the correct answer. Make your choice (1, 2, 3 or 4).  
 Shade the correct oval (1, 2, 3 or 4) on the Optical Answer Sheet (OAS) provided.

1. The classification chart below shows how some things are classified.

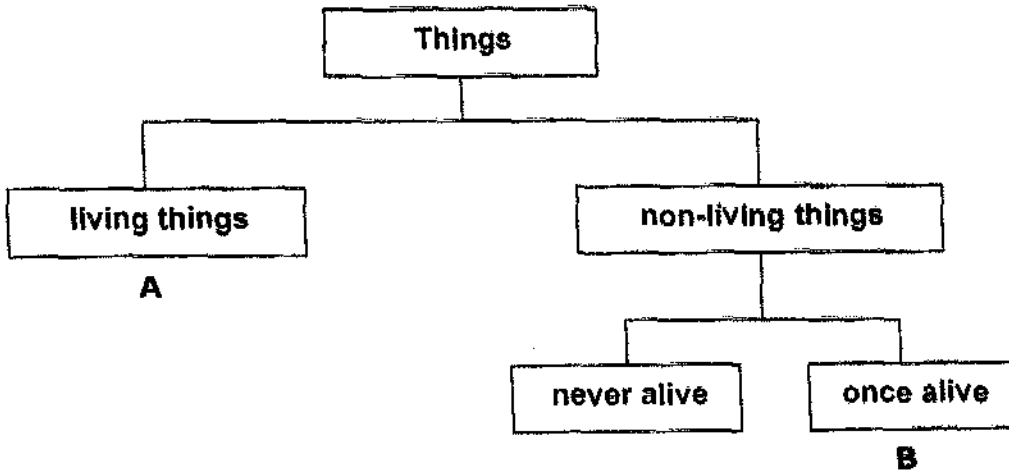

Which one of the following sets represents A and B correctly?

	A	B
(1)	a gorilla	a penguin
(2)	a dolphin	a plastic chair
(3)	a rose plant	a metal can
(4)	bread mould	a story book

1-5

2. Which of the following animals do **NOT** give birth to its young alive?

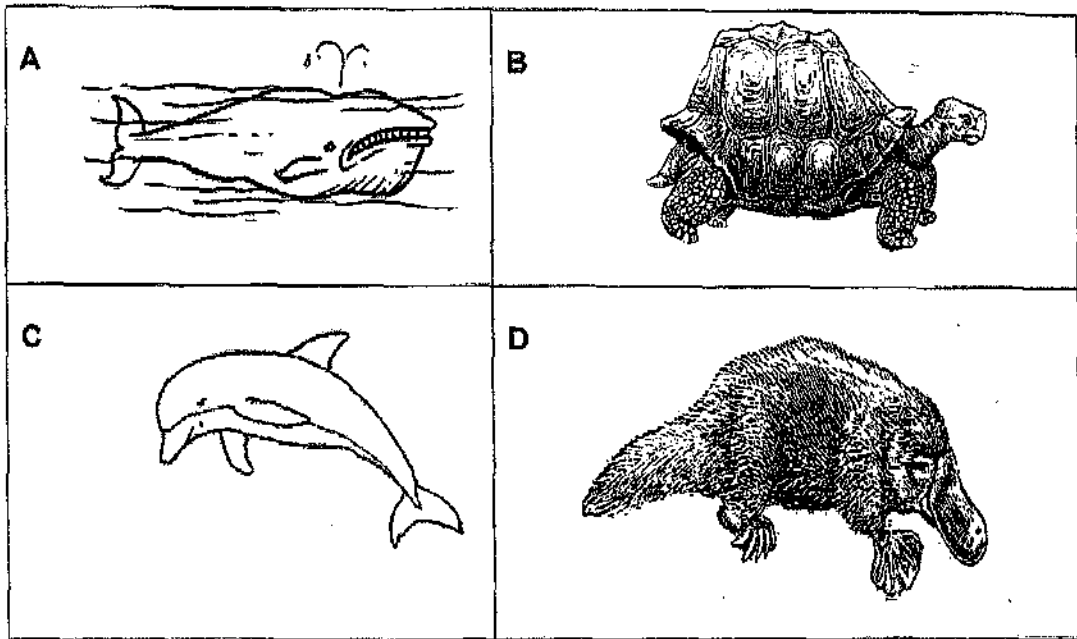

(1) A and B only

(2) A and C only

(3) B and D only

(4) C and D only

3. The diagrams below show organisms X and Y.

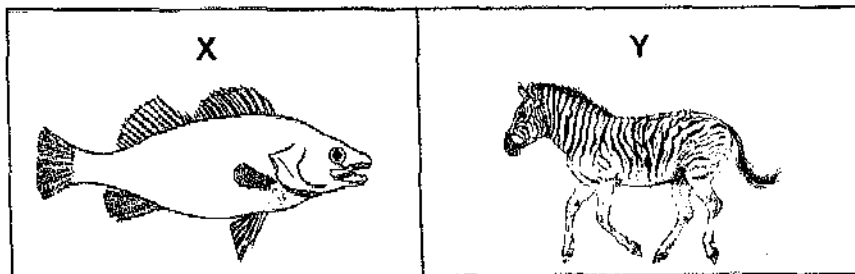

How are both X and Y similar?

A Both need water to survive.

B Both reproduce by laying eggs.

C Both move around to look for food.

D Both have the same outer covering.

(1) A and B only

(2) A and C only

(3) B and C only

(4) C and D only

4. John had four similar plants, A, B, C and D, in four identical pots. He placed each plant under a different set of conditions as shown below.

A tick (✓) shows the presence of the condition.

plant	conditions			
	air	sunlight	water	minerals
A		✓	✓	✓
B	✓	✓	✓	
C	✓	✓		✓
D	✓		✓	✓

Which one of the following sets of plants would **NOT** be able to survive for 2 weeks?

- (1) A, B and C only                      (2) A, B and D only  
 (3) A, C and D only                      (4) B, C and D only

5. The flow chart below shows how some plants are differentiated.

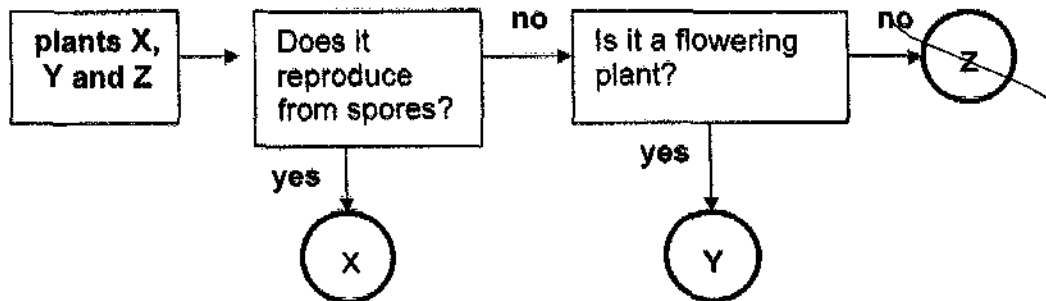

Which one of the following best represents X, Y and Z?  
*and*

	X	Y	Z
(1)	mushroom	rose plant	staghorn fern
(2)	papaya tree	moss	rambutan tree
(3)	rambutan tree	papaya tree	rose plant
(4)	staghorn fern	orchid plant	moss

6. Jenny had four identical clear plastic bags. From the same loaf of bread, she took out 4 pieces of bread of the same size and toasted 2 pieces of bread. She put each piece of bread in a plastic bag as shown in the diagrams below.

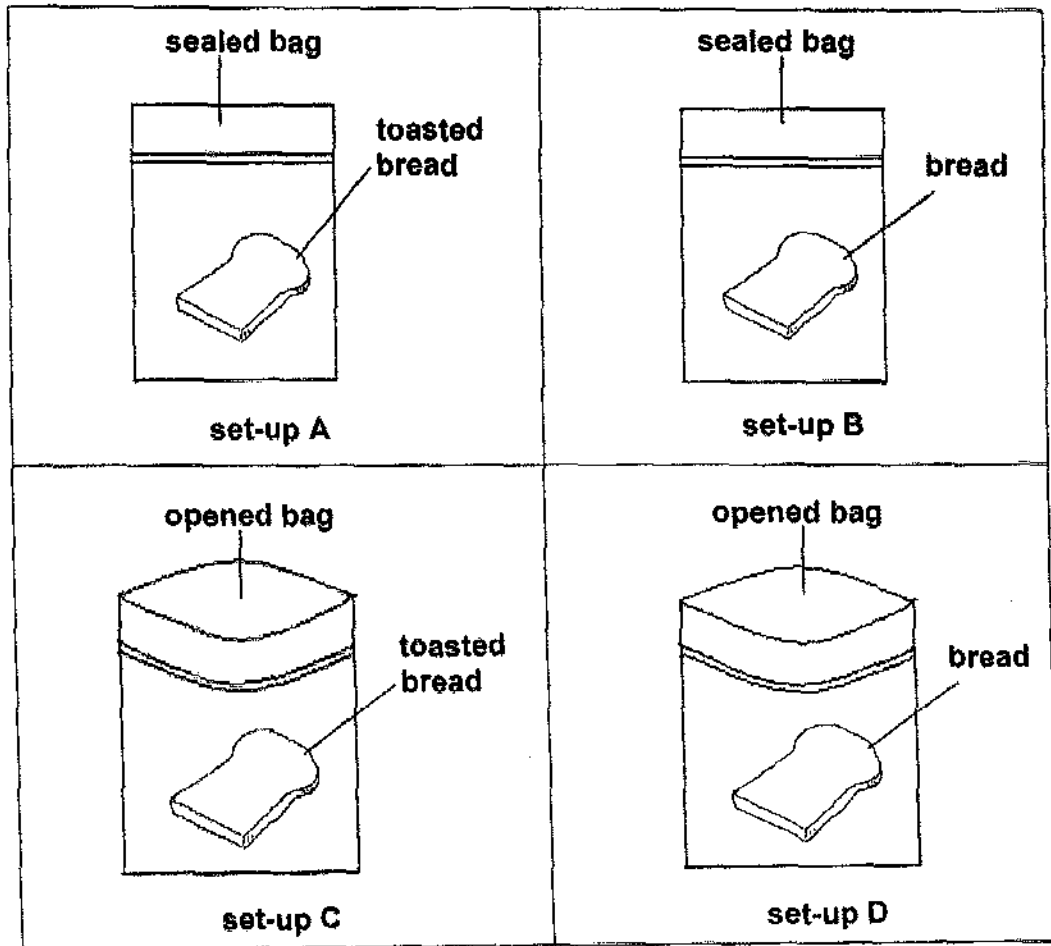

In which of these set-ups would there be the **LEAST** amount of mould growing on the bread after 3 days?

- |              |              |
|--------------|--------------|
| (1) set-up A | (2) set-up B |
| (3) set-up C | (4) set-up D |

7. Sumei grouped some animals as shown in the classification table below.

Group X	Group Y
toad	beetle
cockroach	mosquito
frog	butterfly

The animals are grouped according to \_\_\_\_\_.

- (1) how they reproduce
  - (2) where they are found
  - (3) how they move about
  - (4) the number of stages in their life cycles
8. The diagram below shows the life cycle of an animal X.

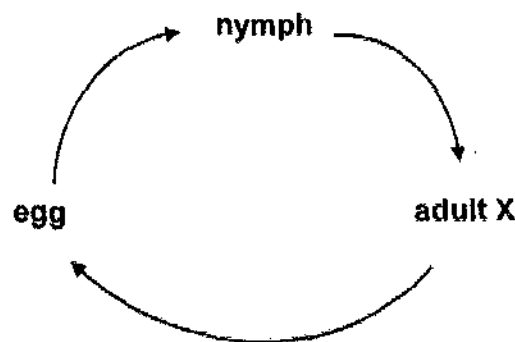

Based on the diagram above, which of the following statements about animal X are correct?

- A Animal X lays its eggs in water.
  - B Animal X has 3 stages in its life cycle.
  - C Animal X does **NOT** give birth to its young alive.
  - D The nymph of animal X has **NO** wings but the adult X has.
- (1) A and B only
  - (2) B and C only
  - (3) C and D only
  - (4) B, C and D only

9. Sumi had 3 identical test tubes. She put in an equal number of seeds in each test tube. Then she placed each test tube in a different location.

Sumi added an equal amount of water to all the test tubes each day.

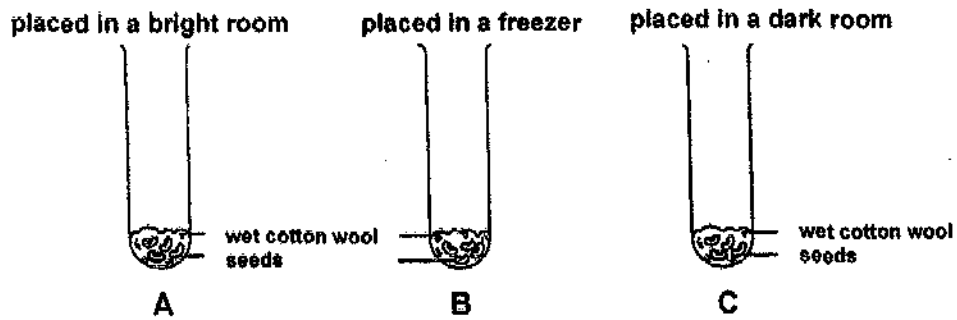

In which of these test tube(s) would the seeds most likely grow after a week?

- (1) A only  
(2) A and C only  
(3) B only  
(4) B and C only

The diagram below shows the growth of one seed over a 5-day period.

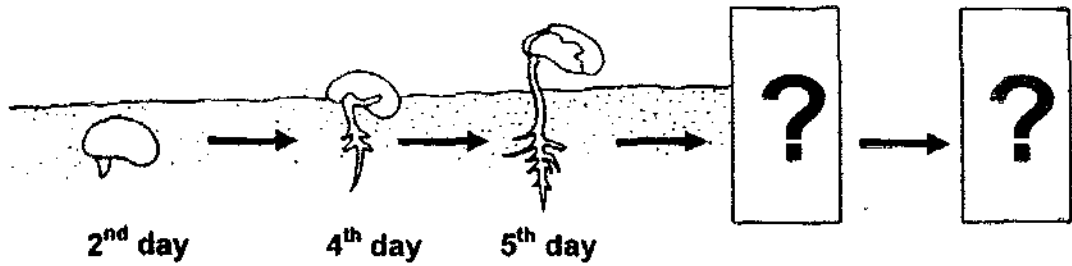

Two stages of the development of the seed are missing.

Based on the information above, answer **questions 10 and 11**.

10. When will the seed be able to make its own food?

- |                         |                                   |
|-------------------------|-----------------------------------|
| (1) 2 <sup>nd</sup> day | (2) 4 <sup>th</sup> day           |
| (3) 5 <sup>th</sup> day | (4) after the 5 <sup>th</sup> day |

11. Which one of the following sets shows the correct missing stages of development of the seed?

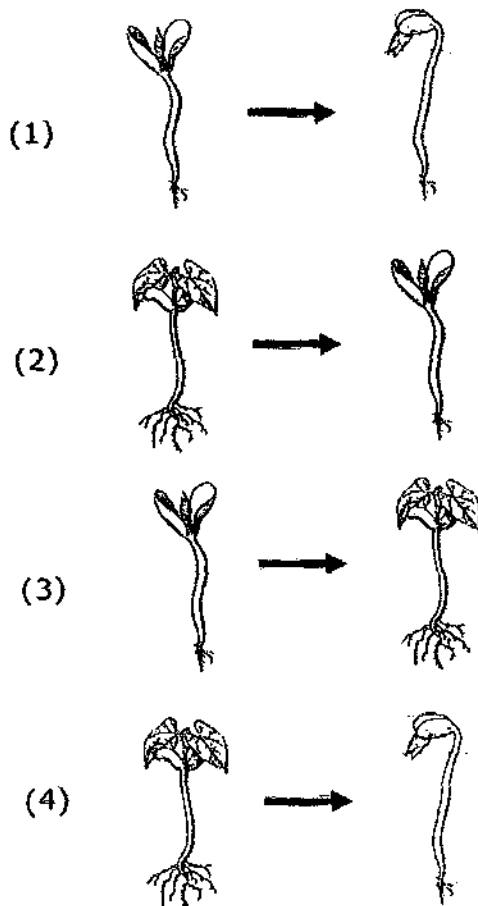

The diagram below shows parts of a young seedling.

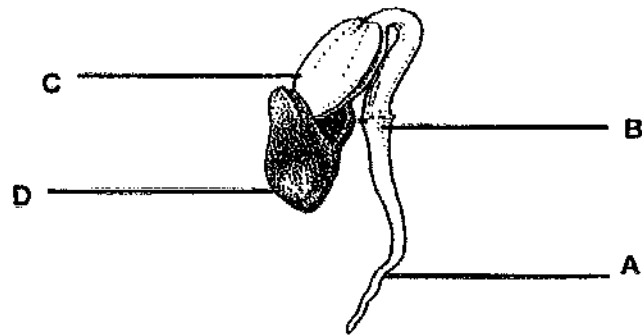

Based on the diagram above, answer questions 12 and 13.

12. Where does the young seedling get its food from?

- |       |       |
|-------|-------|
| (1) A | (2) B |
| (3) C | (4) D |

13. Which one of the following statements about the young seedling is **CORRECT**?

- (1) Part B grows after part A.
- (2) Part A takes in water <sup>and minerals</sup> only.
- (3) The first leaf grows from part D.
- (4) Part C can make food in the presence of light.

The diagram below shows parts of a plant.

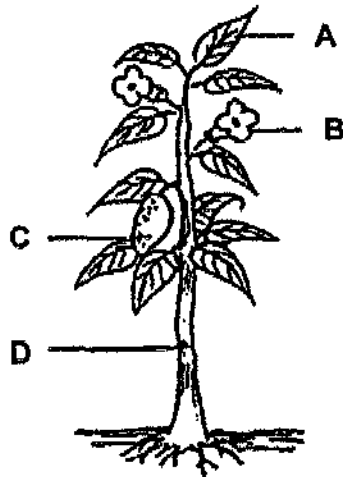

Based on the diagram above, answer **questions 14 and 15**.

14. Which part of the plant protects the seeds?

- |       |       |
|-------|-------|
| (1) A | (2) B |
| (3) C | (4) D |

15. Which of the following is/ are the function(s) of part D of the plant?

- A It takes in minerals.
- B It supports the branches and the flowers only.
- C It carries water from the roots to other parts of the plant.
- D It carries food from other parts of the plant to the leaves.

- |                  |                   |
|------------------|-------------------|
| (1) C only       | (2) B and C only  |
| (3) B and D only | (4) A, B, C and D |

16. Jane set up the following apparatus to conduct an experiment.

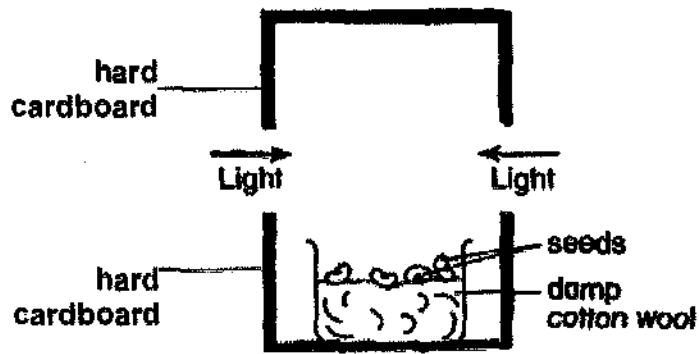

Which one of the following diagrams correctly shows the appearance of the seedlings after one week?

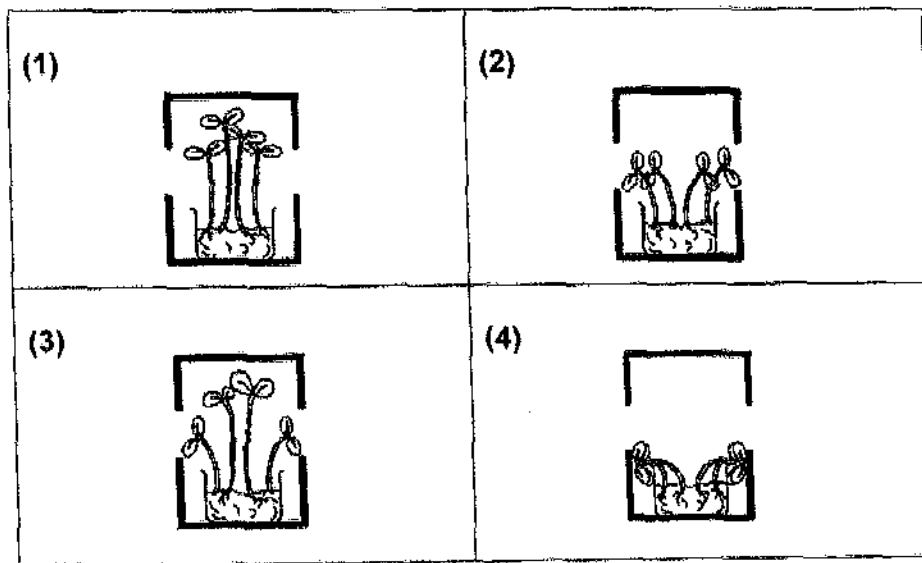

17. The table below shows some objects classified under three different groups: X, Y and Z.

group X	group Y	group Z
shirt	book	nail
handkerchief	newspaper	window grill

The objects in each group are classified according to \_\_\_\_\_.

- (1) how heavy they are
  - (2) what they are made of
  - (3) what they are used for
  - (4) whether they absorb water
18. The diagram below shows a pair of glasses with one of its parts marked Z.



Which one of the following shows correctly what part Z is made of and the reason for the material used?

	material of Z	reason for material used
(1)	glass	It breaks easily.
(2)	plastics	It can bend.
(3)	glass	It allows light to pass through.
(4)	plastics	It absorbs water.



21. Bernice labeled the poles of five bar magnets A to J and arranged them as shown below.

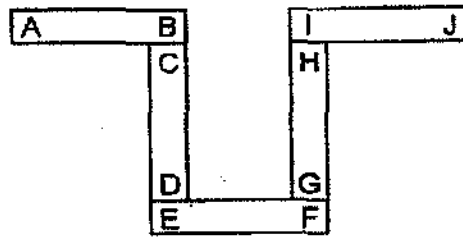

Which one of the following diagrams shows a possible arrangement of two of these magnets?

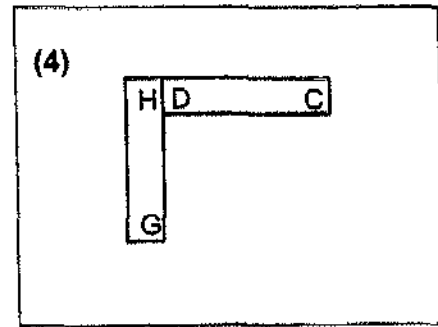
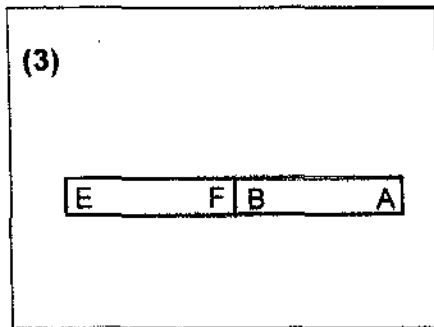
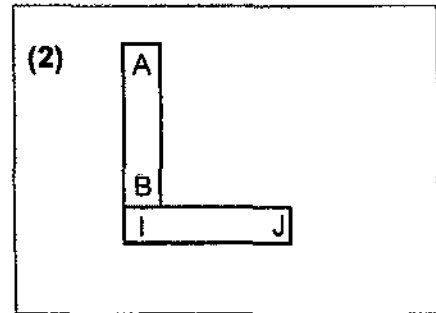
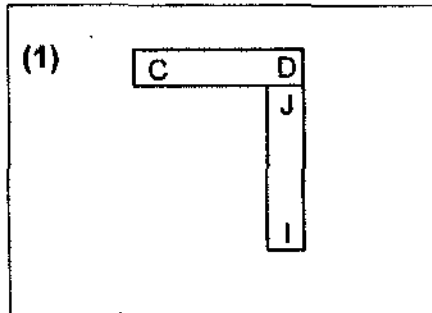

22. Tricia stroked an iron nail with a bar magnet as shown in the diagram below.

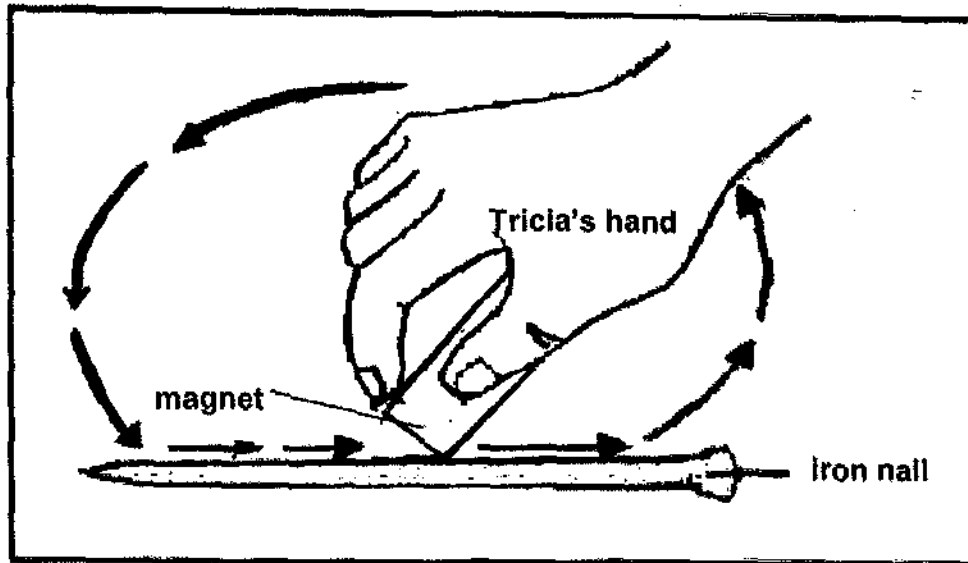

Then she used the iron nail to attract some pins. She repeated the experiment four times, each time increasing 10 strokes in the same direction. She recorded her results in the table as shown below.

number of strokes	number of pins attracted
15	0
25	1
35	1
45	3
55	5

Which of the following actions should Tricia do to increase the number of pins attracted to the iron nail?

- A Hit the iron nail with a hammer.
- B Bring the iron nail further away from the pins.
- C Increase the number of strokes in the same direction.
- D Change the direction in which the iron nail was stroked.

- (1) B only
- (2) C only
- (3) A and B only
- (4) C and D only

23. Genna prepared four set-ups, A, B, C and D, to find out whether the number of coils around an iron affects its magnetic strength.

(Note: All the batteries, wires and iron nails used were the same.)

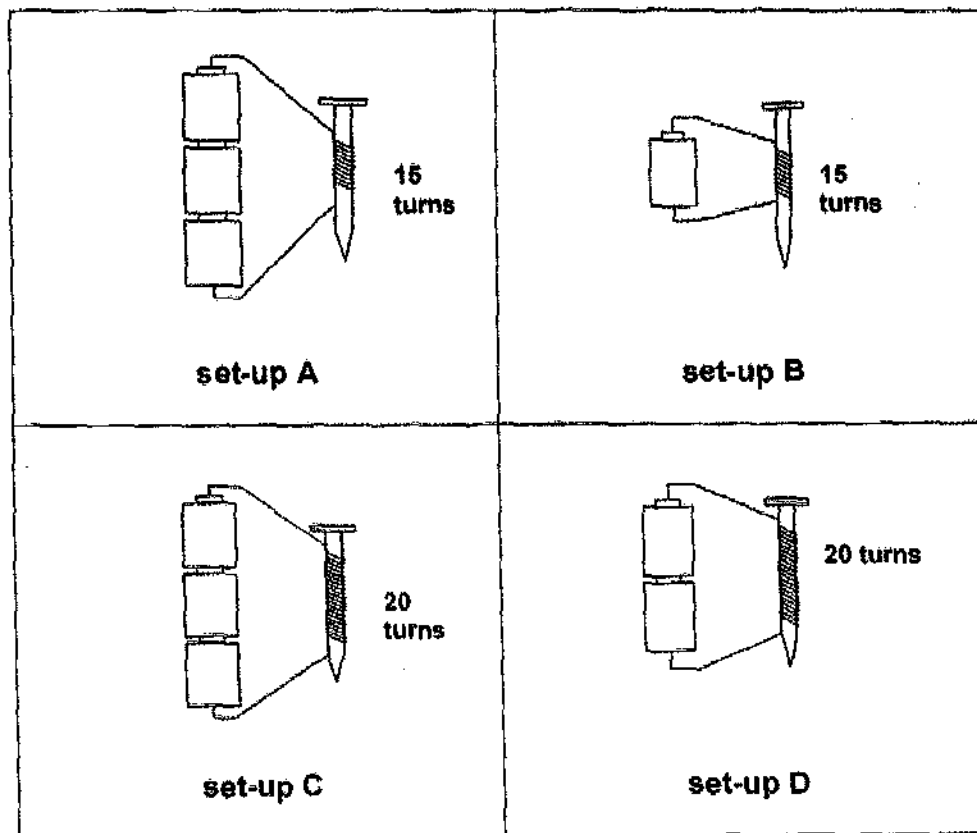

Which two of these set-ups shown above should Genna use to conduct a fair test?

- |             |             |
|-------------|-------------|
| (1) A and C | (2) A and D |
| (3) B and D | (4) C and D |

24. Ali was given the following items: A, B and C.

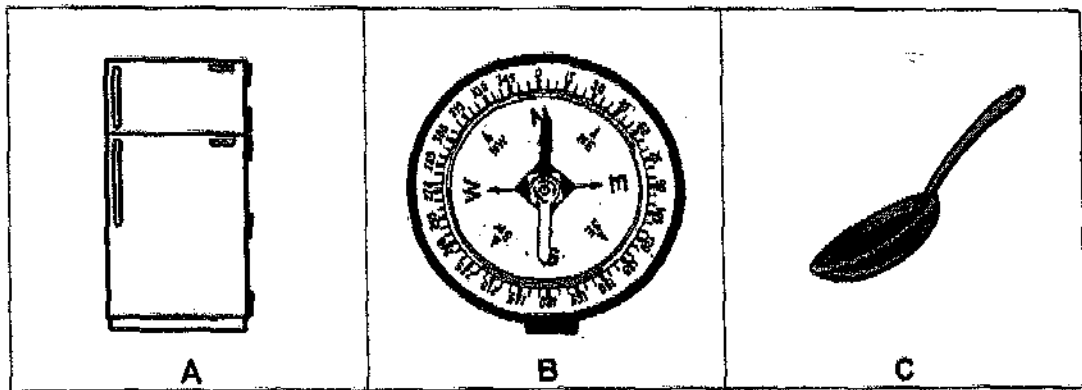

Which of these items make use of magnets?

- (1) A and B only                      (2) A and C only  
(3) B and C only                      (4) A, B and C

**SECTION B (32 marks)**

For questions 25 to 37, write your answers clearly in the spaces provided.

The number of marks available is shown in brackets [ ] at the end of each question or part question.

25. (a) Classify the things (NOT drawn to scale) given in the box below into two groups.

Write letters B, C and D only. Letter A has been written for you.  
Give each group a suitable sub-heading. [3]

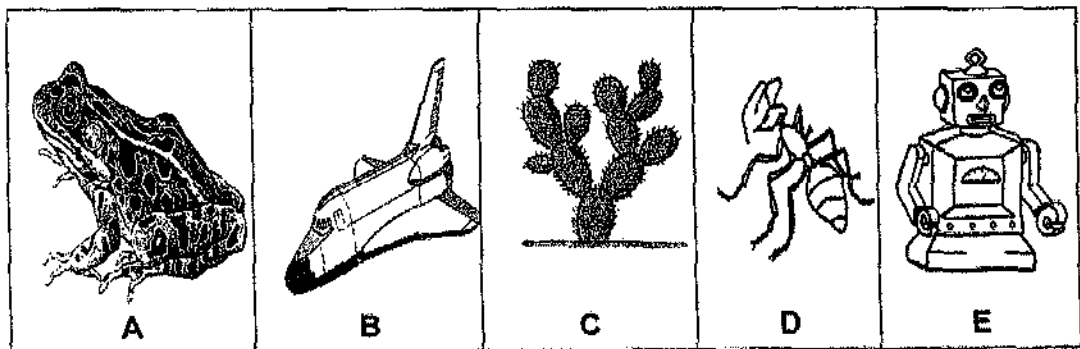

_____	_____
A	

- (b) Name three basic needs of those things grouped with A. [1]

\_\_\_\_\_

- (c) Is there a need for D to move about? Explain your answer. [1]

\_\_\_\_\_  
\_\_\_\_\_

26. The classification table below shows how some animals are grouped.

Complete the classification table with words given in the box below.  
Use each word **ONCE** only.

[2]

bat	pigeon	penguin	seal
-----	--------	---------	------

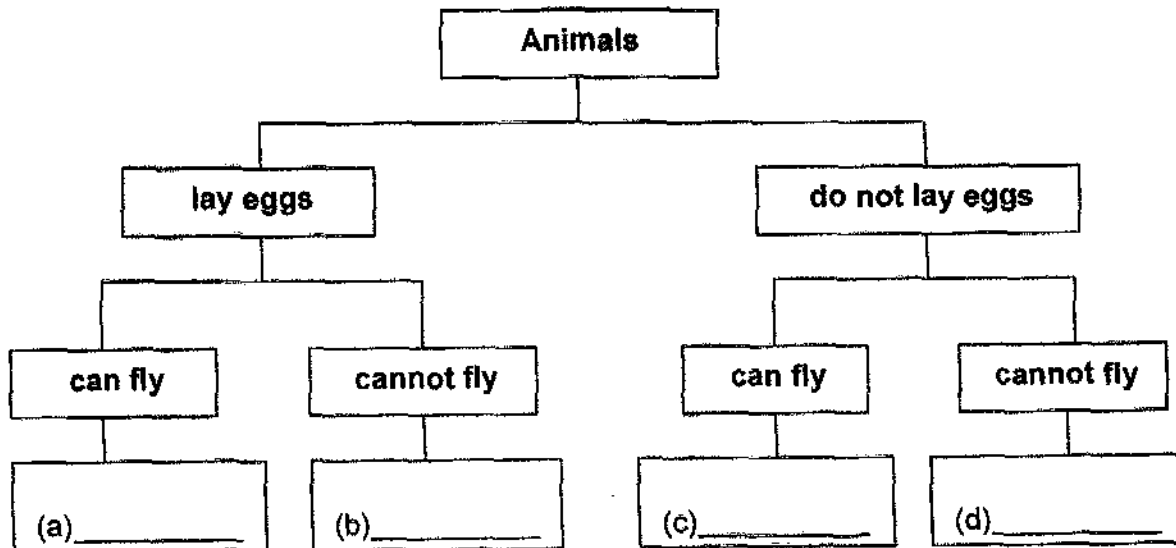

27. The diagrams below show how 8 different types of leaves are grouped according to their physical characteristics.

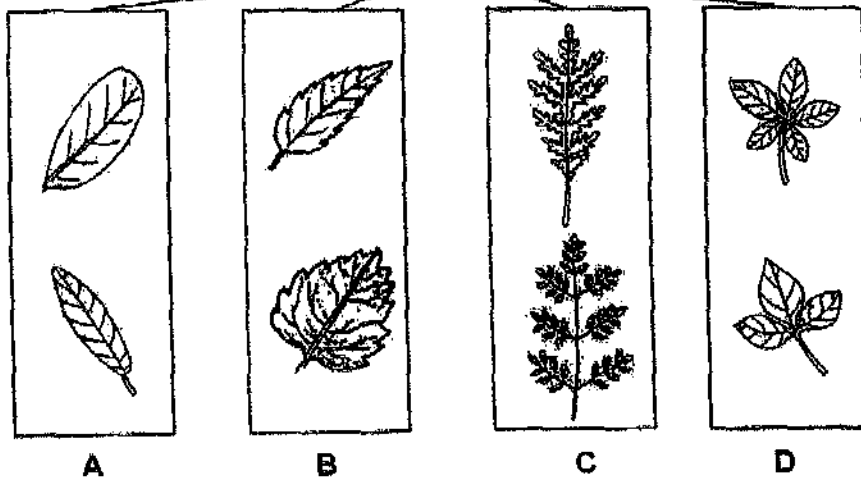
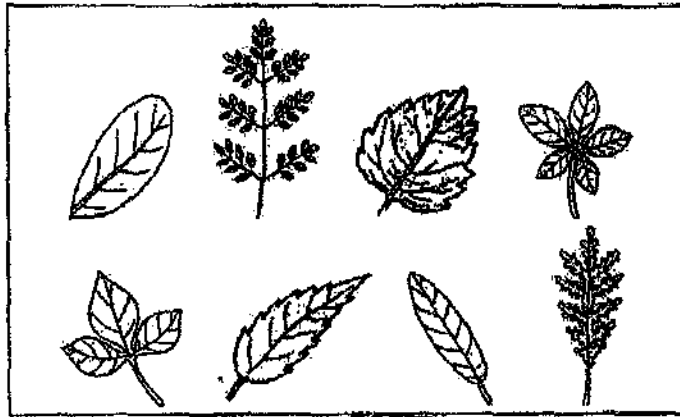

Based on your observations of these leaves, answer the following questions:

- (a) In which one of these groups, A, B, C or D, does the leaf below belong to? [1]



Group \_\_\_\_\_

- (b) State ONE function of leaves. [1]

---



---

28. When Richard touched the mimosa plant, it closed its leaves as shown in Diagram 1 below.

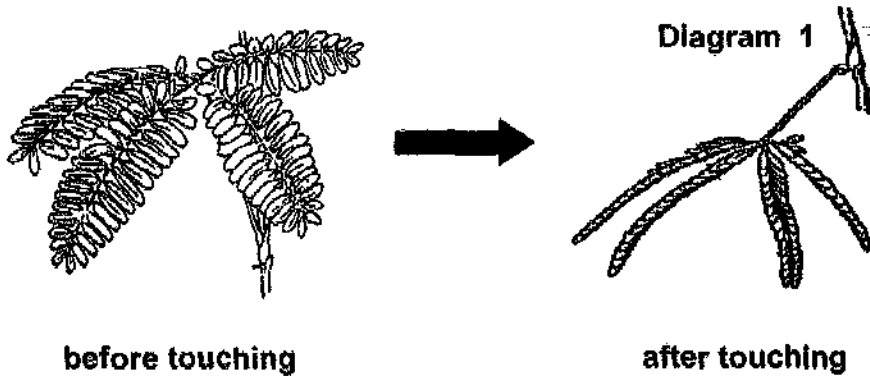

- (a) State **ONE** characteristic of living things based on Richard's observation of the mimosa plant. [1]

---

---

- (b) Richard covered the mimosa plant with a black box. Sufficient water was given to the plant every day.

What would happen to the plant after a week?

Explain your answer. [2]

---

---

---

---

29. The diagrams below show the life cycles of three animals X, Y and Z.

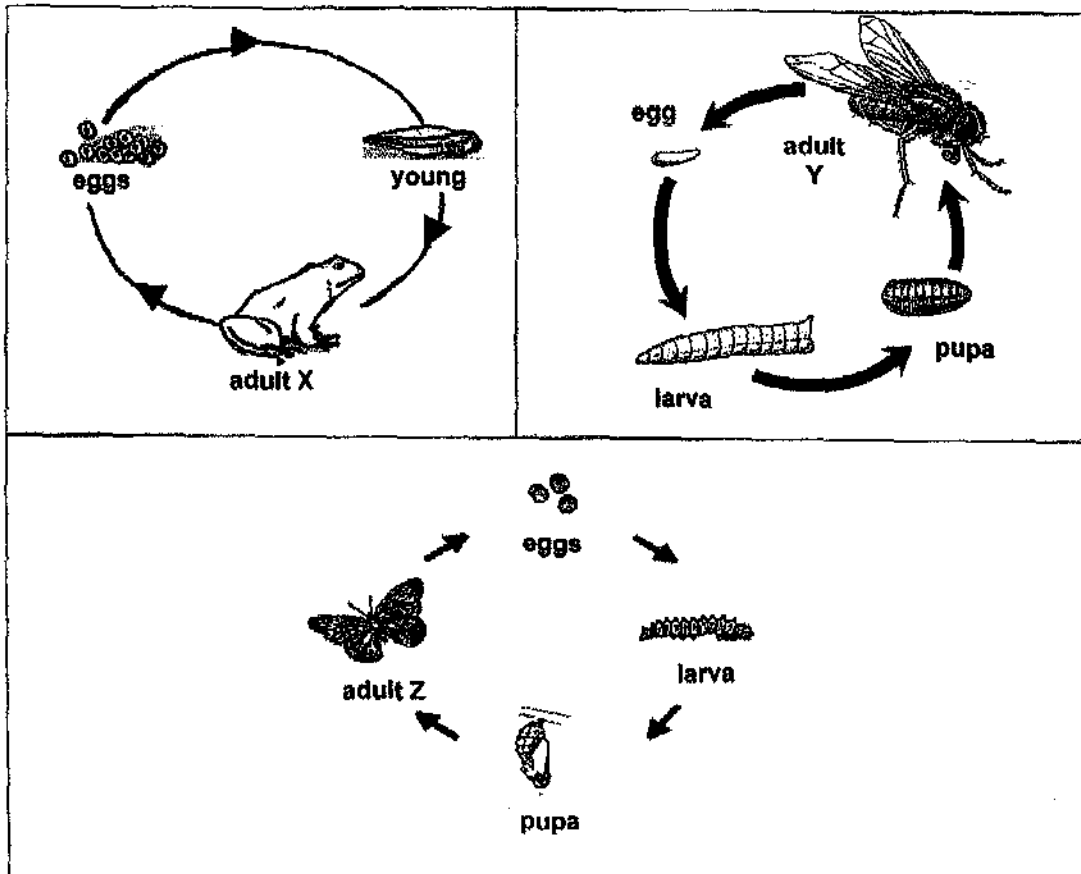

Based on the information above, answer the following questions:

(a) State TWO differences between the life cycles of animals X and Y. [2]

1 <sup>st</sup> DIFFERENCE	
2 <sup>nd</sup> DIFFERENCE	

(b) Give ONE similarity between the life cycles of animals Y and Z. [1]

---

(c) Which of these animals, X, Y and/ or Z, is/ are insect(s)?  
Give a reason for your answer. (Do NOT mention number of legs.) [1]

---



---

30. Harry placed an equal number of seeds in three identical test tubes. Each test tube of seeds was placed under a different set of conditions as shown below.

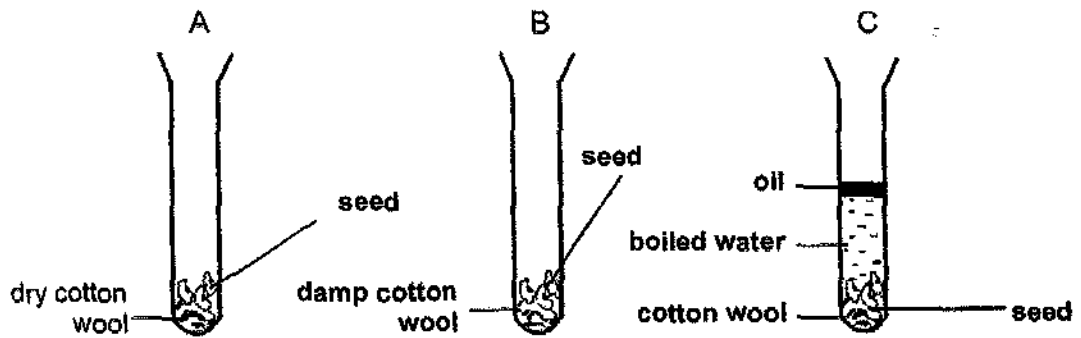

Based on the information above, answer the following questions:

In which of these set-ups, A, B and/ or C, would the seeds **NOT** be able to germinate?

Explain your answer(s).

[2]

---

---

---

---

31. Judy measured and recorded the height of a tree as shown below:

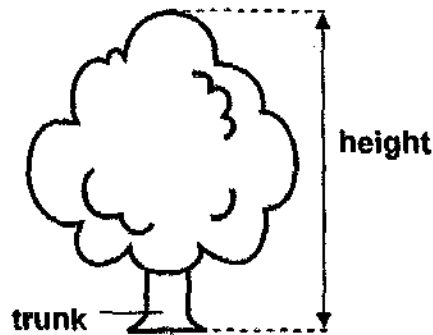

Judy has 5 such trees in her garden. She measured and recorded each of their heights according to their age as shown in the table below:

tree	A	B	C	D	E
age (years)	1	2	3	4	5
height (cm)	100	115	200	220	300

Based on the information above, answer the following questions:

- (a) What can Judy conclude about the height of the trees as they grow older? [1]

---

---

- (b) Judy noticed that there was a layer of thick covering known as the bark on each of the tree trunks.

What is the function of the bark? [1]

---

---

32. Some seedlings were grown in the set-up as shown below.

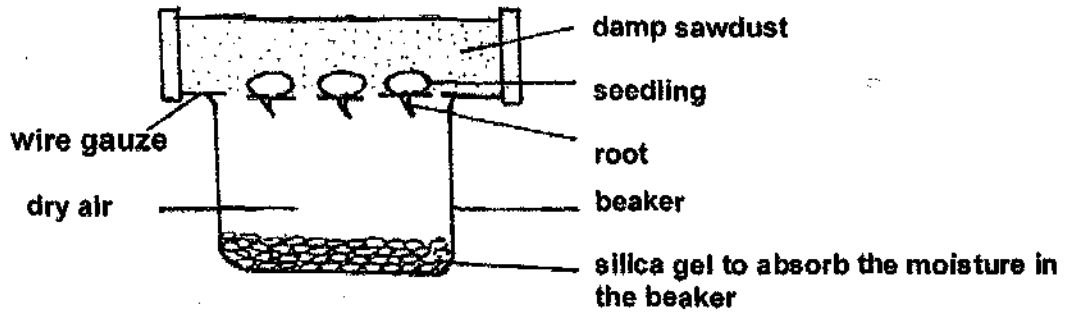

Based on the information above, answer the following questions:

What would be observed of the roots after a few days?

Give a reason for your answer.

[2]

---

---

---

33. The diagrams below show how some plants grow.

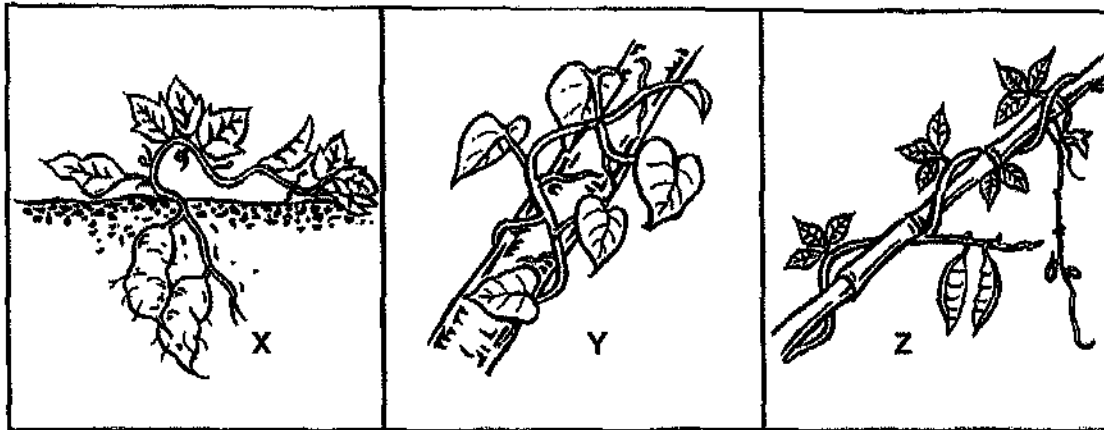

Based on the diagrams above, answer the following questions:

(a) Give a reason why these plants **CANNOT** stand upright.

[1]

---

---

(b) Which **TWO** of these plants can possibly grow on a fence?

[1]

---

34. A carpenter uses a hammer to hit a nail into a piece of wooden plank.

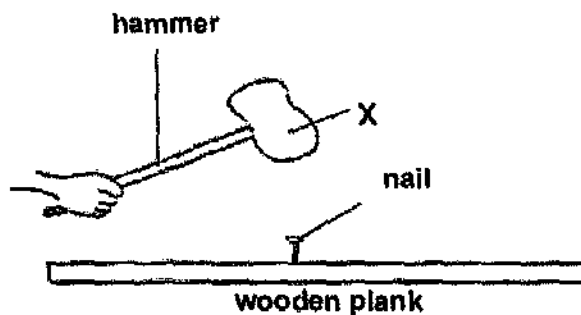

Name a suitable material used to make part X of the hammer.

Give a reason for your choice of material.

[1]

---

---

---

35. Mark has an umbrella with its different parts labelled X and Y as shown in the diagram below.



Answer the following questions to complete the table below.

- (a) Suggest suitable material(s) to make parts X and Y. [1]
- (b) Give a reason for each material selected. [2]

part	material	reason for material used
X		
Y		

36. Two magnets, A and B, of the same size, were used in the following experimental set-ups. Each of the two trays placed below the magnets contained the same number of iron pins at the start of the experiment.

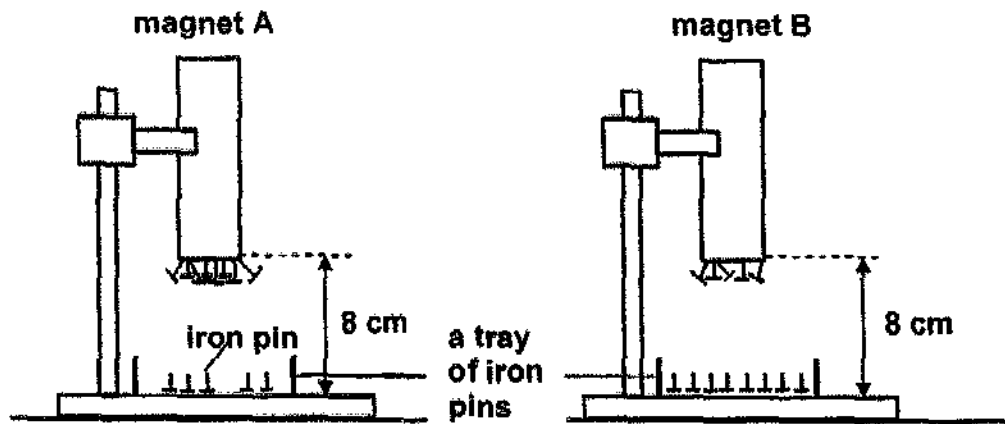

- (a) Based on the experimental set-ups above, compare magnets A and B in terms of their magnetic strength. [1]

In the experiment below, part A of object Q was attracted to the N-pole of magnet X.

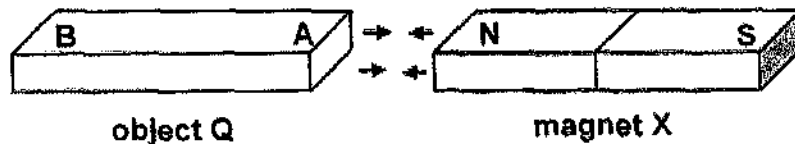

- (b) Based on the information above, which of the following statement(s) is / are 'true', 'false' or 'not possible to tell'?

Put a tick ( ✓ ) in the correct boxes below. [1]

	statement	true	false	not possible to tell
(i)	Object Q is a magnet.			
(ii)	The South pole of the magnet X would attract part B of object Q.			

37. Two identical magnets were each tied to a toy car, W and X, with a string as shown in the diagram below.

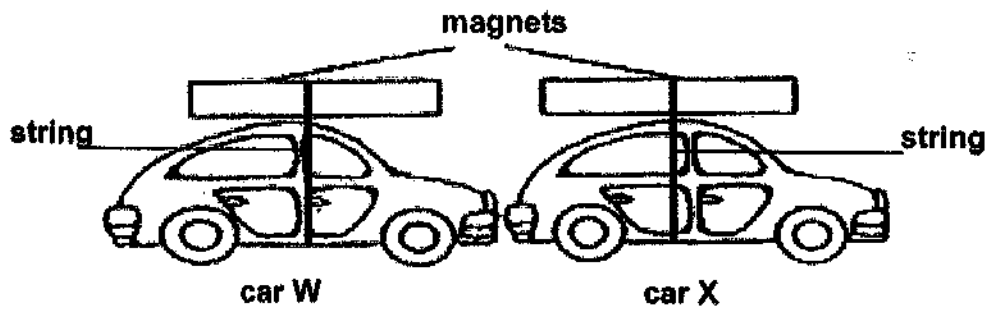

- (a) When car W was brought close to car X, car W moved away from car X.

Explain why this happened.

[1]

---



---

Shannon placed a steel toy car on a plastic sheet and held a magnet under the sheet. When she moved the magnet to the left, she observed that the toy car moved in the same direction, as shown in the diagram below.

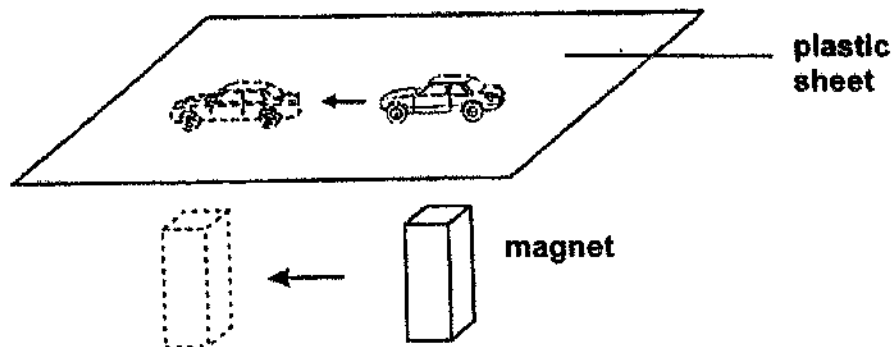

Next, Shannon replaced the plastic sheet with a new sheet made of material K. When she moved the magnet under the sheet made of material K to the left, she observed that the toy car did **NOT** move.

- (b) Based on the information above, suggest what material K could be.

Explain your answer based on Shannon's observation.

[1]

---



---



---

- END OF PAPER -

Setters: Mrs Elaine Lim, Ms Chong V, Mr Darren Lau



# RAFFLES GIRLS' PRIMARY SCHOOL

## 2009 PRIMARY 3 SEMESTRAL ASSESSMENT 2 ANSWER KEY

Setters: Mrs Elaine Lim, Ms Vin Chong, Mr Darren Lau

### SECTION A (24 X 2 marks)

1.	4
2.	3
3.	2
4.	3
5.	1

6.	2
7.	4
8.	2
9.	2
10.	4

11.	3
12.	3
13.	Void
14.	4
15.	1

16.	2
17.	2
18.	3
19.	4
20.	3

21.	2
22.	2
23.	1
24.	1

### SECTION B (32 marks)

No	Marks	Answers	Remarks									
25.	(a)	3	<p><b>Concept / idea:</b> To observe, compare and classify things into living and non-living things.</p> <table border="1" style="margin-left: auto; margin-right: auto;"> <tr> <th style="width: 50%;">living things</th> <th style="width: 50%;">non-living things</th> </tr> <tr> <td style="text-align: center;">A</td> <td style="text-align: center;">B</td> </tr> <tr> <td style="text-align: center;">C</td> <td style="text-align: center;">E</td> </tr> <tr> <td style="text-align: center;">D</td> <td></td> </tr> </table>	living things	non-living things	A	B	C	E	D		<p>-[½] for wrong spelling of words in bold</p> <p>[½] for each correct</p> <ul style="list-style-type: none"> <li>▪ sub-heading</li> <li>▪ group of letters</li> </ul> <p>NO partial marks</p>
	living things	non-living things										
	A	B										
C	E											
D												
(b)	1	<p><b>Concept / idea:</b> To state the three basis needs of living things</p> <ul style="list-style-type: none"> <li>▪ air (oxygen)</li> <li>▪ water</li> <li>▪ food</li> </ul>	<p>Max. deduction: -[½] for wrong spelling</p> <p>NO partial marks</p>									
(c)	1	<p><b>Concept / idea:</b> To state the reasons why living things especially animals need to move.</p> <p>Yes.</p> <p>D needs to move about to</p> <ul style="list-style-type: none"> <li>▪ look for food</li> <li>▪ look for water</li> <li>▪ look for shelter</li> <li>▪ get away from its enemies</li> <li>▪ get away from its predators</li> </ul>	<p>NO marks for wrong choice of answer</p> <p>-If no legs cannot find food. [0m]</p> <p>Accept any one of the reasonable answer</p>									

26.		2	<p><b><u>Concept / Ideas:</u></b>  <b>To be able to classify animals according to their groups and know how they reproduce.</b></p> <p>a) pigeon  (b) penguin  (c) bat  (d) seal</p>	<p>[½] for each correct answer</p> <p><b>NO</b> marks for wrong spelling</p>
27.	(a)	1	<p><b><u>Concept / idea:</u></b>  <b>To classify leaves based on their physical characteristics e.g the type of edge</b></p> <p><b>B</b></p>	
	(b)	1	<p><b><u>Concept / idea:</u></b></p> <p><b>To state the characteristics of living things based on the information given</b></p> <p>It responds to changed around it.</p> <p>Award [½] for any one of the following:</p> <ul style="list-style-type: none"> <li>▪ It can move when touched.</li> <li>▪ It responds to touch.</li> </ul>	<p>- [½] for wrong spelling of word in bold</p> <p>Other non-living things can also move when touched.</p>

28.	(a)	1	<p><b>Concept / idea:</b> To state the characteristics of living things based on the information given.</p> <p>It responds to changes around it/stimuli/changes/ changes in the environment</p> <p><b>Not accepted:</b></p> <ul style="list-style-type: none"> <li>it responds/ responds to environment (0 m)</li> </ul>	<p>-[½] for wrong spelling of word in bold</p> <p>Other non-living things can also move when touched.</p>
	(b)	2	<p><b>Concept / idea:</b> To be able to predict what happens when plants do not get enough sunlight.</p> <p><b>Prediction:</b> It would wither/ turn yellow. (1m)</p> <p><b>Explanation:</b> It needs sunlight to make food. (1m) It can't make food without sunlight. (1m) It can't get sunlight. (1/2 m) It can't get air and sunlight (1/2m)</p> <p><b>NOT accepted.</b> It needs air, warmth, water and sunlight. (0m)</p>	<p>Mark independently</p> <p>-[½] for wrong spelling of word in bold</p>

No	Marks	Answers	Remarks
29.	(a)	<p><b>Differences (accept one of the following)</b></p> <ul style="list-style-type: none"> <li>- Animal X has 3 stages in its lifecycle but animal Y has 4 stages in its life cycle.</li> <li>- Animal Y has larval stage but animal X does not have.</li> <li>- Animal Y has larval and pupa stages but X does not have.</li> <li>- Animal Y develops wings in its adult stage but NOT animal X.</li> </ul> <p><b>NOT accepted</b></p> <ul style="list-style-type: none"> <li>- Animal Y has wings but animal X does not have.</li> </ul> <p>* Description of the development of the different stages of the animal in its life cycle can be accepted as answer, but not mere physical appearance difference.</p>	<p>→ NOT acceptable from 2009 onwards</p>
	(b)	<p><b>Similarity</b></p> <ul style="list-style-type: none"> <li>- Both have 4 stages in their life cycles. (1m)</li> <li>- Both have an egg stage</li> <li>- Both have larval stage/ pupa stage. (1m)</li> <li>- Both go through egg stage, larval stage, pupa and adult stage.</li> <li>- Both reproduce from eggs / by laying eggs.</li> <li>- Their young do not resemble the adult.</li> </ul>	<p>→ NOT acceptable from 2009 onwards.</p>

			<p><b>Not accepted</b> Both start from egg stage.(0m)</p>	
	(c)		<p>Answer Y and Z ( 1/2m) Explanation</p> <p>Both animals have (a pair of) feelers/ antennae (1/2 mark) Both have three body parts. (1/2m) Both develop from egg to larva.</p> <p>*Correct insect Y or Z with correct explanation is given half mark. e.g Y is an insect as it has a pair of feelers. (1/2 m only)</p> <p><b>Not accepted</b> Both have wings/ Both go through larva and pupa stage (0m)</p>	→ NOT acceptable from 2009 onwards (?)
30.		2	<p><b>Concept / idea:</b> <b>To compare all the given set-ups and state the conditions necessary for seeds to germinate</b></p> <p>Setup A: it did not have water / it needs water to grow(1 mark) Setup C: it did have oxygen/air , air cannot go in as it is blocked by the oil (1m)</p> <p>* NO mark for correct setups with wrong explanation.</p>	<p><b>NO</b> partial marks.</p> <p><b>NO</b> marks for wrong set-ups chosen.</p> <p>Marks awarded for each set of correct answer i.e. choice set-up A and explanation for it <b>MUST</b> be correct</p> <p>For full marks: <b>BOTH</b> set-ups must be mentioned.</p>

31.	(a)	1	<p>As the trees grow older, they <u>grow taller</u>. OR The trees <u>grow taller</u> as they grow older.</p> <hr/> <p>Other acceptable answers:</p> <p>Their height <u>increased</u> [1] Their height is <u>taller/ longer / higher</u> [½]</p> <p><b>[0] for the following answers:</b> - Number of height gets bigger - Their height can grow</p>	<ul style="list-style-type: none"> <li>• ½ for each underlined word</li> <li>• no deduction for wrong spelling of height</li> </ul> <p><b>Action needed by Science teacher:</b></p> <p><b>Pupils with the following answer:</b></p> <p>- Their height can grow</p>
-----	-----	---	---	--

			→ Teacher deducts ½ that was originally given by Vin
	(b)	1 To <b>protect</b> the <b>trunk</b>  [½] for this answer: - Protect the <b>trees</b> (which part of the tree?)  [0] for the following answer:  - Protect <b>xylem and phloem</b> / <b>phloem</b> (½ for protect), (-½ for wrong concept)	-[½] for ▪ To protect the stem ▪ wrong spelling: trunk or protect
32.		2 <b>[1] Observation:</b> They would <b>grow upwards</b> [½] towards the <b>damp sawdust</b> [½].  <b>[1] Reason:</b> The roots <b>take in water</b> [½] in order for the seeds to <b>germinate/grow</b> [½].  <i>The roots absorb water as the seeds need water, warmth, oxygen to germinate.</i> ----- Other acceptable reasons but ½ point: - roots grow towards water - roots were looking for water  <b>[0] for the following reason:</b> - <i>roots need water, oxygen, warmth to germinate</i>	2 keywords must be in place to receive ½: • grow, upwards • damp, sawdust  <b>1<sup>st</sup> action needed by Science teacher:</b> - check that 'damp' is written along with 'sawdust'  →
33.	(a)	1 ▪ They have <b>weak stems</b> . / <b>not have strong stems</b> ----- [½] for: <i>they are creepers</i> (no reference to plant part: stem)  [0] for: <b>vines</b> too weak <b>they</b> are weak <b>they</b> have <b>thin</b> stems / <b>flexible</b> stems <b>they</b> are <b>non-woody</b> stems [Justification: balsam is non-woody but it can support itself]	<b>1<sup>st</sup> action needed by Science teacher:</b>  - 1 pupil with "do not have hard stem" → Teacher deducts 1 point
	(b)	1 Y and Z	[½] for each correct answer

34.		1	<p><b>Concept / Idea:</b> To state the material used based on its properties</p> <p><b>Choice of material:</b> metal</p> <p><b>ACCEPT:</b> any mention of any specific metal e.g. iron, steel</p> <p><b>Explanation:</b> X is strong</p>	<p><b>NO</b> marks for wrong choice of material even if explanation is correct</p> <p>Mark the question as a <b>WHOLE</b></p> <p>-[½] for wrong spelling of metal</p>													
35.		3	<p><b>Concept/ Idea:</b> To state the material used based on its properties</p> <table border="1" data-bbox="373 947 995 1491"> <thead> <tr> <th>Part</th> <th>[½m each] Material</th> <th>[1m each] Reason</th> </tr> </thead> <tbody> <tr> <td rowspan="2">X</td> <td>Wood</td> <td>It gives structural support.</td> </tr> <tr> <td>Metal Plastic(s)</td> <td>It is hard / strong</td> </tr> <tr> <td rowspan="2">Y</td> <td>Plastic(s) Nylon</td> <td>It is waterproof. It does not absorb water.</td> </tr> <tr> <td>Metal</td> <td>To hold onto the plastic firmly, giving the umbrella its shape.</td> </tr> </tbody> </table>	Part	[½m each] Material	[1m each] Reason	X	Wood	It gives structural support.	Metal Plastic(s)	It is hard / strong	Y	Plastic(s) Nylon	It is waterproof. It does not absorb water.	Metal	To hold onto the plastic firmly, giving the umbrella its shape.	<p>[½] For each correct material</p> <p>[1] For each correct reason of the material selected</p> <p>Award marks for (a) and (b) independently.</p> <p>(a) / (b) mark holistically. i.e. reason must match material chosen.</p>
Part	[½m each] Material	[1m each] Reason															
X	Wood	It gives structural support.															
	Metal Plastic(s)	It is hard / strong															
Y	Plastic(s) Nylon	It is waterproof. It does not absorb water.															
	Metal	To hold onto the plastic firmly, giving the umbrella its shape.															
36.	(a)	1	<p><b>Concept / Idea:</b> To compare the magnetic strength of magnet based on the number of pins that each can attract</p> <p>Magnet A is stronger than magnet B. <b>OR</b></p> <p>Magnet A has a greater magnetic strength than magnet B.</p>	<p><b>NO</b> partial marks</p> <p>Do <b>not</b> accept more magnetism.</p>													

	(b)	1	<p><b>Concept / idea:</b>  <b>To read from the information / diagram given and deduce that only a magnet can repel another magnet when their like poles face each other</b></p> <p>(i) not possible to tell  (ii) true</p>	[½] for each correct answer
37.	(a)	1	<p><b>Concept / idea:</b>  <b>To know that like poles repel from each other</b></p> <p>Like poles of magnets on cars W and X were facing each other [½] and they / like poles repelled. [½]</p>	
	(b)	1	<p><b>Concept / Idea:</b>  <b>To name the magnetic material and explain that magnetism cannot pass through magnetic materials based on the information given</b></p> <p>Material K could be</p> <ul style="list-style-type: none"> <li>▪ iron</li> <li>▪ steel</li> <li>▪ nickel</li> <li>▪ cobalt</li> </ul> <p>▪ Magnetism / Magnetic force of the magnets  -cannot pass through  -is blocked by magnetic materials.</p>	<p>[½] for correct material.  [½] for correct explanation.</p>