



RED SWASTIKA SCHOOL

RED SWASTIKA SCHOOL

2009 SEMESTRAL ASSESSMENT 2

SCIENCE

Name : _____ ()

Class : Primary 3/ ____

Date : 29 October 2009

BOOKLET A

30 Questions

60 Marks

Duration of Paper : 1 h 15min

Note:

1. Do not open this Booklet until you are told to do so.
2. Questions 1 to 30 are to be done on the OAS provided.
3. Read carefully the instructions given at the beginning of each part of the Booklet.
4. Do not waste time. If a question is difficult for you, go on to the next one.
5. Check your answers thoroughly and make sure you attempt every question.

SECTION A – Multiple Choice Questions (30 X 2 marks each)

Read the following questions carefully. Choose the best answer (1, 2, 3 or 4) and shade the corresponding oval on the Optical Answer Sheet (OAS).

1. Living things _____ to ensure the continuity of their kind.

- (1) die
- (2) grow
- (3) reproduce
- (4) respond to changes

2. Which of the following are the functions of the circulatory system?

- A. Enables the body to move.
- B. Enables the exchange of gases with the surroundings.
- C. Carries oxygen and digested food to all parts of the body.
- D. Carries waste materials away from all parts of the body to be removed.

- (1) A and B only
- (2) B and C only
- (3) B and D only
- (4) C and D only

3. The animals below are grouped according to their outer covering. What is X?

Group A	Group B	Group C
crocodile	jaguar	eagle
snake	bear	emu
molly	spiny anteater	X

- (1) penguin
- (2) platypus
- (3) swordfish
- (4) grasshopper

4. Study the two pictures carefully.

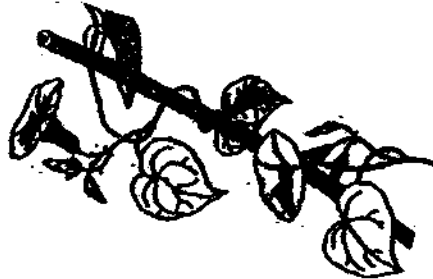

Morning glory

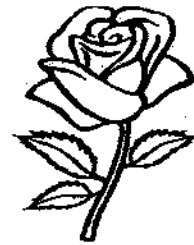

Rose plant

Which of the following statements are true?

- A. They have different types of stems.
- B. Their leaves are of different types of edges.
- C. One of them can make food but the other cannot.
- D. One of them is a land plant but the other is a water plant.

- (1) A and B only
- (2) A and C only
- (3) B and C only
- (4) B and D only

5. The following statements describe what happens after the food we eat has travelled down the gullet into the stomach. They are not in the correct order.

- A. The digested food passes into the blood.
- B. After a few hours, the food goes into the small intestine.
- C. The solid waste is passed out of the body through the anus.
- D. The undigested food goes into the large intestine and water is removed from it.

Which of the following shows the correct order?

- (1) A → D → C → B
- (2) B → A → D → C
- (3) C → B → A → D
- (4) D → C → B → A

6. Study the table below carefully and determine which one of the following is correct.

		<i>Taken in by</i>	<i>Given out by</i>
(1)	Water	Roots	Roots
(2)	Mineral salts	Roots	Flowers
(3)	Air	Leaves	Leaves
(4)	Water	Stem	Roots

7. The table below provides information on the characteristics of four plants, W, Y, X and Z.

	W	X	Y	Z
<i>Grows on land</i>	No	No	Yes	Yes
<i>Have flowers</i>	Yes	No	Yes	No

Study the following classification chart.

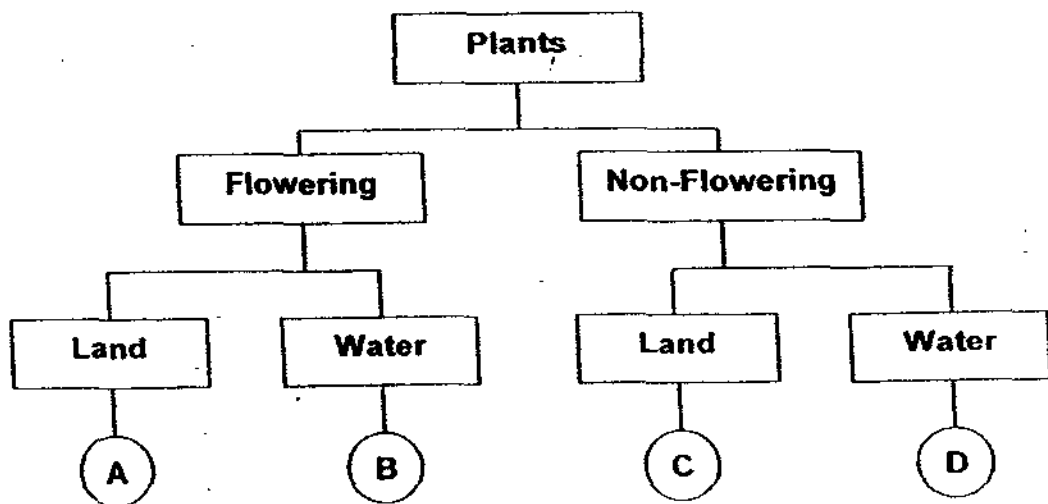

Based on the information given in the table above, Plant Z belongs to Group _____ in the classification chart.

- (1) A
 (2) B
 (3) C
 (4) D

8. Which of the following organ systems work together with the respiratory system to enable us to breathe?

- A. Skeletal
- B. Muscular
- C. Circulatory

- (1) A and B only
- (2) B and C only
- (3) C and D only
- (4) A, B and C

9. Study the flowchart carefully.

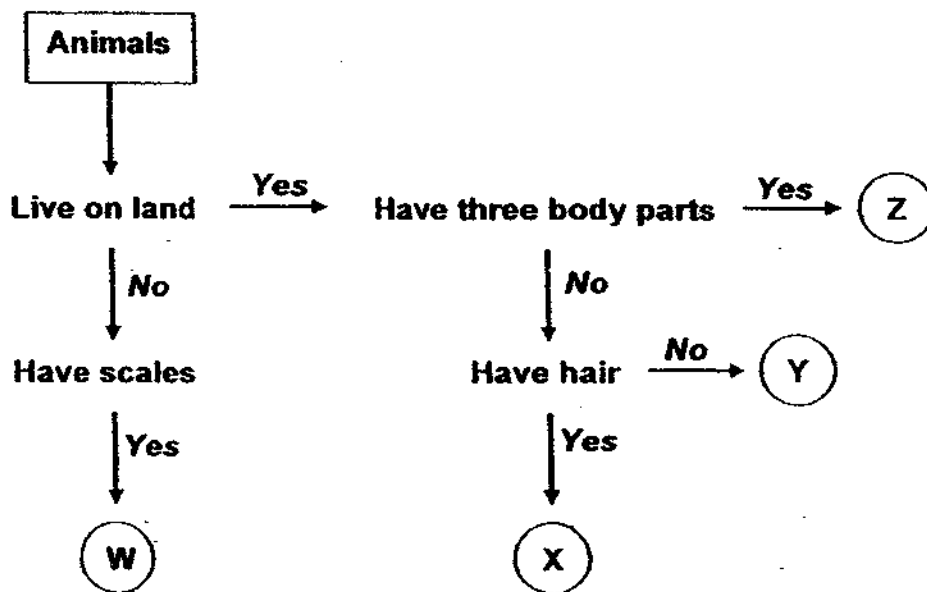

Which of the following is correct?

	W	X	Y	Z
(1)	Bird	Insect	Mammal	Fish
(2)	Insect	Bird	Fish	Mammal
(3)	Mammal	Fish	Insect	Bird
(4)	Fish	Mammal	Bird	Insect

10. John had two pots of similar plants. They were given enough water and covered with boxes made from different materials. Then, they were placed in an open field for one week. After one week, he observed that only the plant in the box made of wood died.

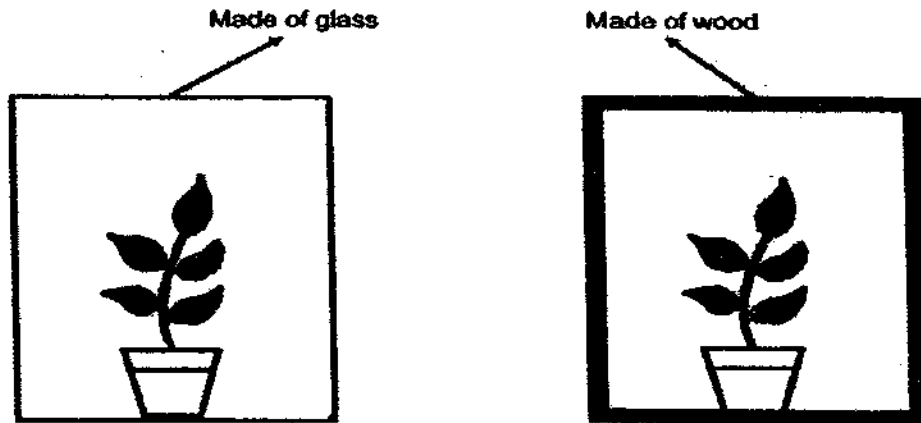

This experiment tells us that plants need _____ to survive.

- (1) food
- (2) water
- (3) light
- (4) fertiliser

11.

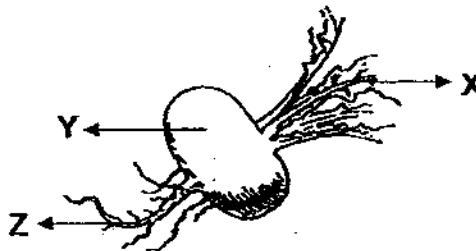

The above shows a picture of a turnip plant. How is the part 'Y' useful to the plant?

- A. It serves as food storage organ.
- B. It prevents soil from being washed away by the rain easily.
- C. It provides support by holding the plant firmly to the ground.
- D. It helps to take in water and mineral salts needed for growth.

- (1) A only
- (2) B only
- (3) B and D only
- (4) C and D only

12. Study the classification chart as shown below.

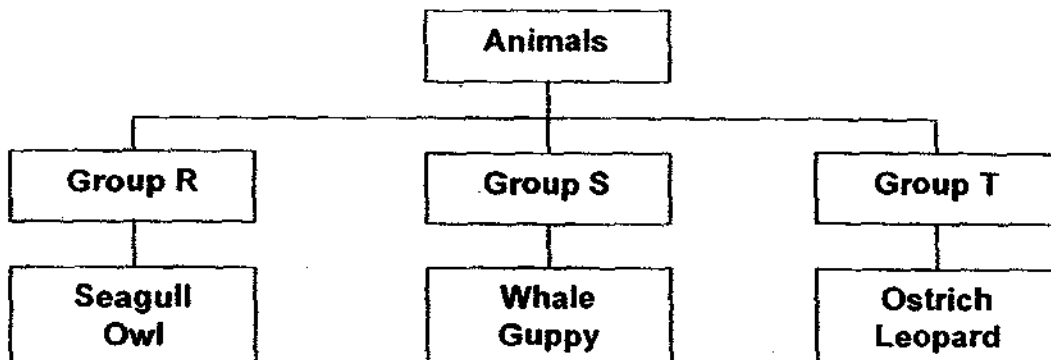

These animals are classified according to _____.

- (1) the place they live
- (2) the way they move
- (3) their outer coverings
- (4) the way they reproduce

13. Jeremy fed a chick with some food. He then placed the chick in a wooden box as shown below.



The chick died after a while. Which one of the following systems will be the **first** to be affected directly?

- (1) Muscular system
- (2) Digestive system
- (3) Circulatory system
- (4) Respiratory system

14. The diagram below shows some parts of a plant.

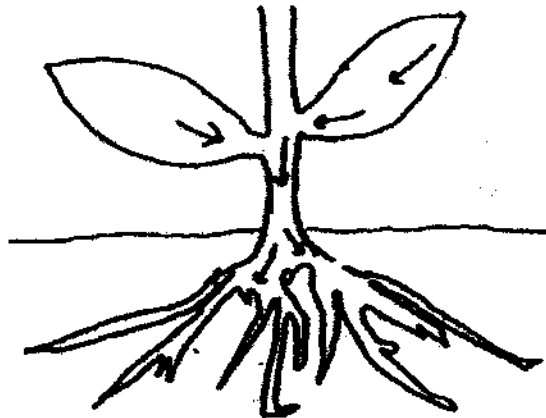

The arrows in the diagram show the path taken by _____ in the plant.

- (1) food
 - (2) water
 - (3) sunlight
 - (4) mineral salts
15. Which of the following statements is correct?
- (1) All bacteria are harmful.
 - (2) All bacteria can be used to produce food.
 - (3) Bacteria only need warmth and air to live.
 - (4) Some types of bacteria can make their own food.

16. The stem of the plant shown below was ***bent accidentally*** before it was planted into the pot. The plant was given water and it received enough sunlight. However, it died a few days later.

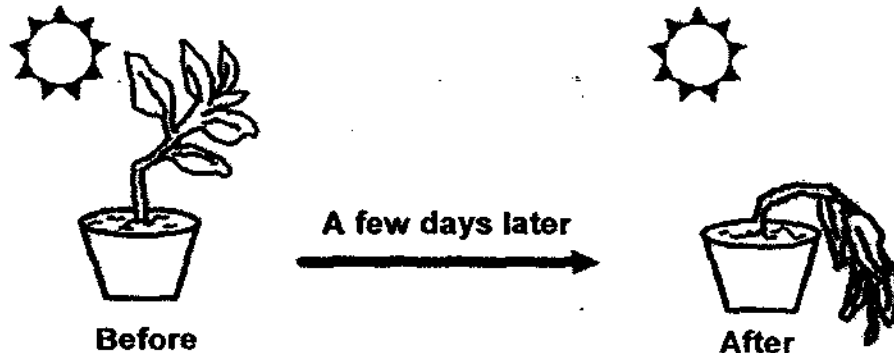

Which of the following statements **best** describes what had happened to the above plant?

- (1) The plant was not held firmly to the soil.
 - (2) The leaves did not make enough food for the plant.
 - (3) The broken tubes in the stem could not transport water.
 - (4) The roots did not take in enough mineral salts and water from the soil.
- 17.



Look at the above picture. Which system(s) in the man's body is/are involved in helping him to play football?

- A. Skeletal
 - B. Muscular
 - C. Circulatory
 - D. Respiratory
- (1) B only
 - (2) A, B and D only
 - (3) B, C and D only
 - (4) A, B, C and D

18. The diagram below shows what happens when three ring magnets are placed around a wooden stick.

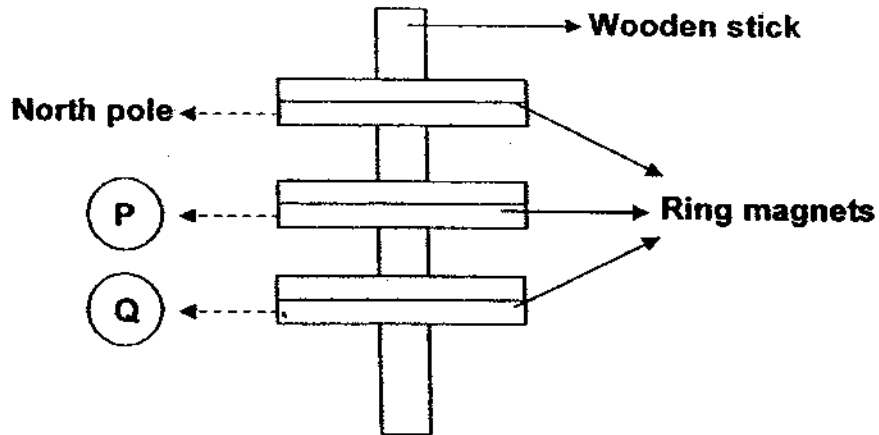

Which poles could be P and Q be?

	P	Q
(1)	North	North
(2)	North	South
(3)	South	North
(4)	South	South

19. The picture below shows some balloons.

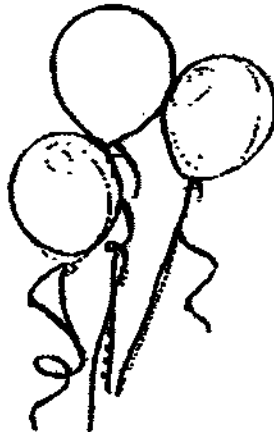

Rubber is used to make the balloons because it is _____.

- (1) hard
- (2) strong
- (3) flexible
- (4) smooth

20. Two magnets are placed next to each other as shown. If Q is the South pole of the magnet, what will most likely happen to the toy car?

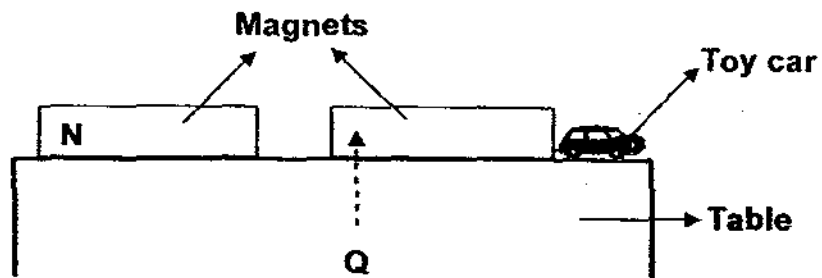

The toy car will _____.

- (1) stay where it is
- (2) become a magnet
- (3) move nearer to the magnet
- (4) be knocked off the edge of the table

21. Ali wants to find out if an object is a magnet, he can _____.

- A. hit it with a magnet
- B. drop to see if it breaks
- C. test if it heats up quickly
- D. check if it attracts a nickel coin

- (1) C only
- (2) D only
- (3) A and B only
- (4) C and D only

22. Which one of the following groups does not consist of living things?

- (1) fire, wind, rain
- (2) yeast, mushrooms, ferns
- (3) tadpoles, crabs, dolphins
- (4) maggots, moths, peacocks

23. Four toy fishes of different materials were placed into a large tank of water as shown below.

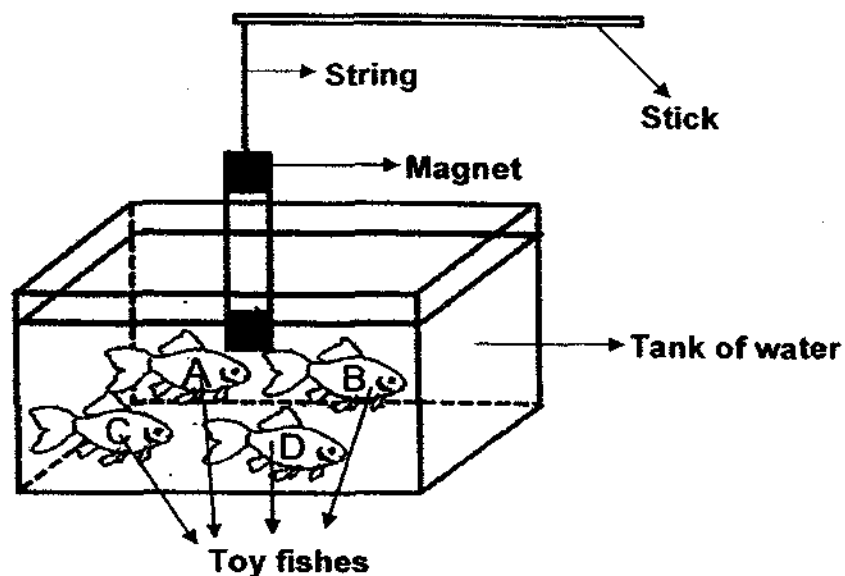

Only Toy fish A and D were attracted by the magnet. What materials could Toy fish A and D be made of?

- (1) iron and steel
 - (2) iron and copper
 - (3) steel and copper
 - (4) steel and aluminium
24. When making a magnet using the 'stroke' method, the strength of the magnet can be increased by _____.
- (1) stroking it repeatedly in all directions
 - (2) stroking it more times in the same direction
 - (3) heating it with a flame in the same direction
 - (4) dropping it several times from different heights

25. Study the flow chart carefully.

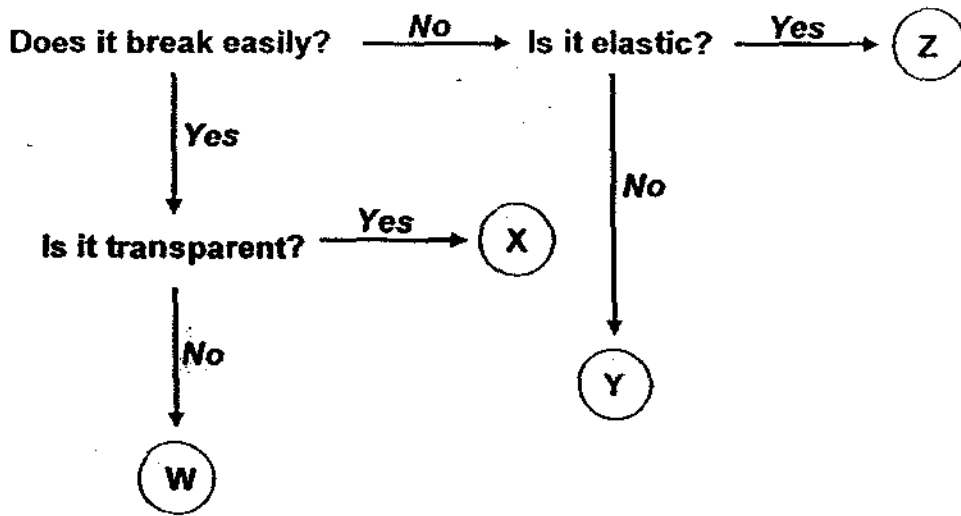





Which of the following is correct?

	W	X	Y	Z
(1)	Clay	Glass	Metal	Rubber
(2)	Rubber	Clay	Glass	Metal
(3)	Metal	Rubber	Clay	Glass
(4)	Glass	Metal	Rubber	Clay

26. Which direction will the N-pole of a freely suspended bar magnet point to when it is at rest?

- (1) North-South direction
- (2) North-West direction
- (3) South-East direction
- (4) East-West direction

27. Which of the following does not make use of magnets?

(1)  Toaster oven	(2)  Refrigerator
(3)  Telephone	(4)  Battery

28. Four magnets, W, X, Y and Z are hanging from strings of two different lengths as shown in the diagram below.

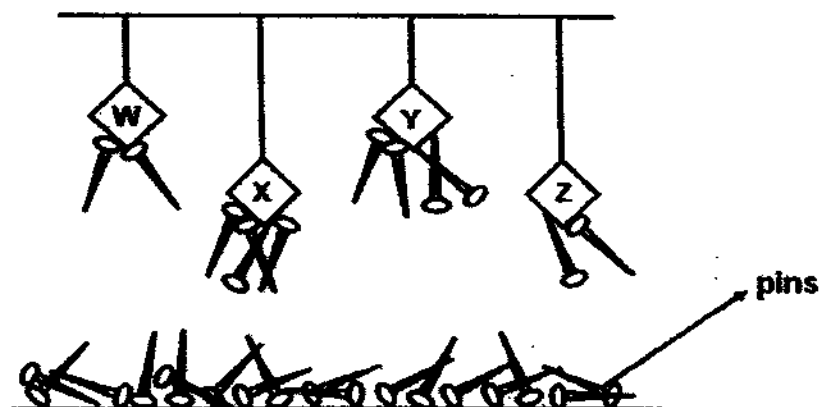

Pins are placed below the magnets and different numbers of pins are attracted to the magnets. Which is the strongest magnet?

- (1) W
- (2) X
- (3) Y
- (4) Z

29. Four sheets of materials, M, N, O and P of the same size, were weighed individually before they were put into four beakers until they were covered completely by equal amounts of water in each beaker. After 5 minutes, each sheet was weighed again. The measurements were recorded in the table below.

Material	Weight before putting into the beaker	Weight after 5 minutes
M	6g	12g
N	10g	23g
O	13g	20g
P	16g	17g

Which material is most suitable for use in making an umbrella?

- (1) M
- (2) N
- (3) O
- (4) P

30. Study the flowchart carefully to find out whether an unknown object, P, Q, R, S, is a magnet, magnetic or non-magnetic material.

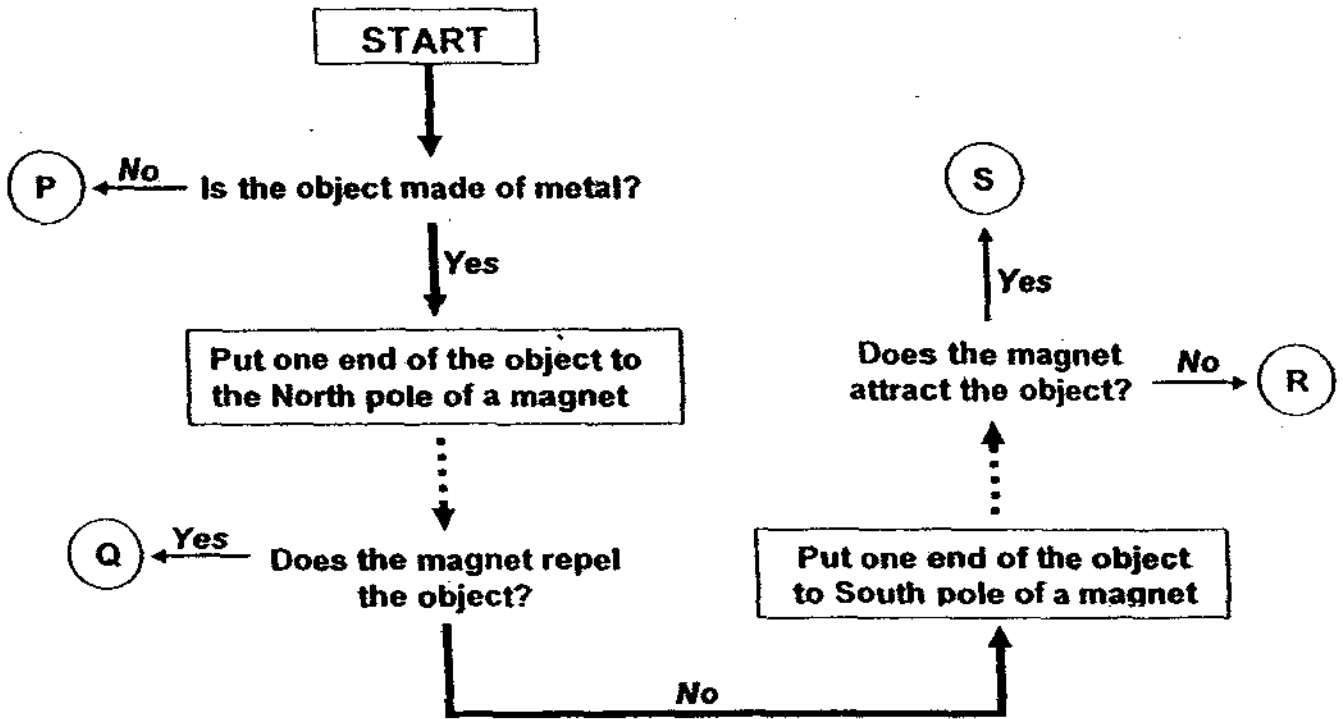

Which object best represents a steel rod?

- (1) P
- (2) Q
- (3) R
- (4) S

End of Section A



RED SWASTIKA SCHOOL

RED SWASTIKA SCHOOL

2009 SEMESTRAL ASSESSMENT 2

SCIENCE

Name : _____ ()

Class : Primary 3/ _____

Date : 29 October 2009

BOOKLET B

14 Questions
40 marks

MARKS

	OBTAINED	POSSIBLE
BOOKLET A		60
BOOKLET B		40
TOTAL		100

Parent's Signature : _____

SECTION B : Open-Ended Questions (14 Questions: 40 marks)

Write your answers to the following questions in the spaces provided.

31. Study the classification chart.

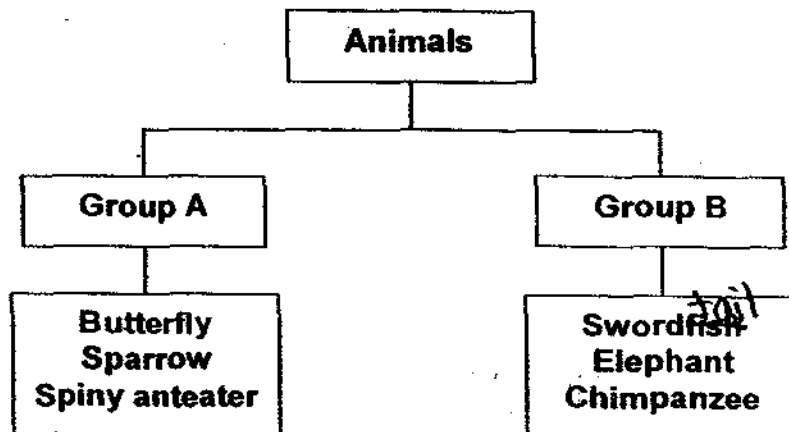

a) Give a suitable heading for each group. (1 mark)

i) Group A: _____

ii) Group B: _____

b) Which group will the following animals be classified under? Write the group letter (A or B) in the space provided. (1 mark)

i) Guppy: Group _____

ii) Silverfish: Group _____

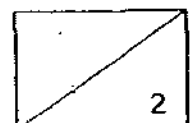

32. The diagram below shows a leaf with one of its parts missing.

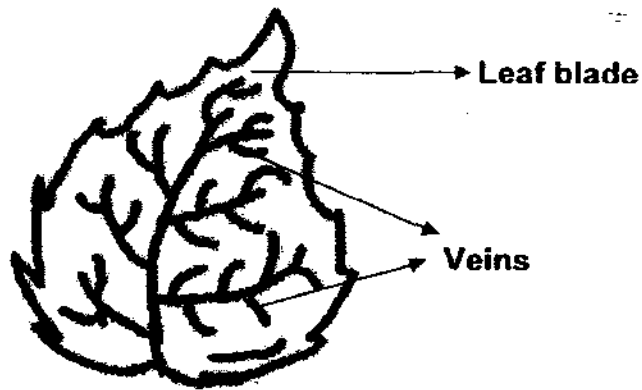

a) Draw the missing part on the diagram above. (1 mark)

b) Why is the missing part of the leaf mentioned in part (a) important?
(1 mark)

c) Write down the main function of the leaf. (1 mark)

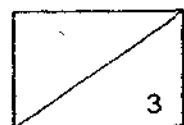

33. Look at the pictures below.

Ant

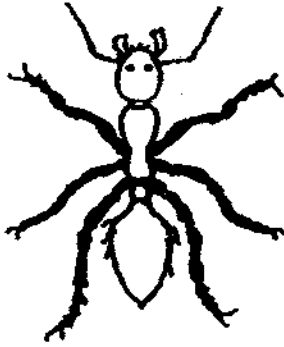

Bee



a) Name the group of animals they belong to. (1 mark)

b) **Based on the pictures only**, write down one similarity and one difference between the body parts of the two animals. (Do not compare colour, shape and size.) (2 marks)

i) Similarity: _____

ii) Difference: _____

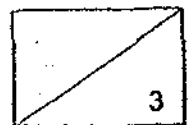

34. The diagram below shows a human digestive system. Study it carefully and answer the questions that follow.

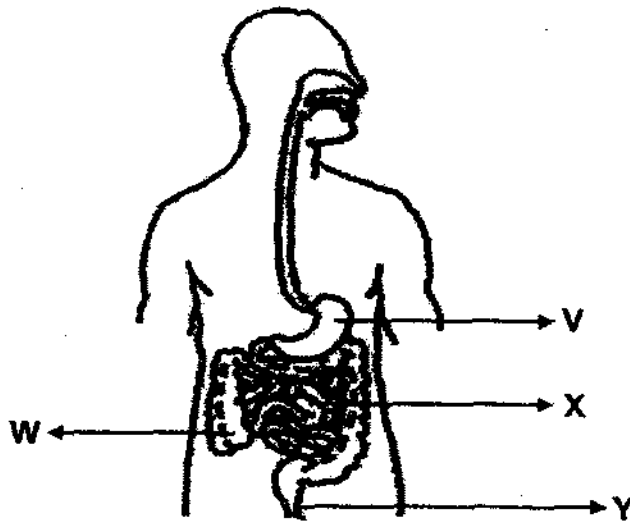

Name _____

- a) Part V and Part W. (1 mark)

i) V: _____

ii) W: _____

- b) What is found in Parts V and X that causes the change in the amount of undigested food? (1 mark)

- c) At which part (V, W, X, Y) will the digestion be completed? (1 mark)

Part _____

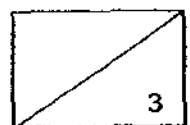

35. One day, Xiao Ming removed a plant from the ground to be replanted into a pot. The pot was then placed in the garden where there was enough sunlight. Xiao Ming also gave the plant sufficient water.

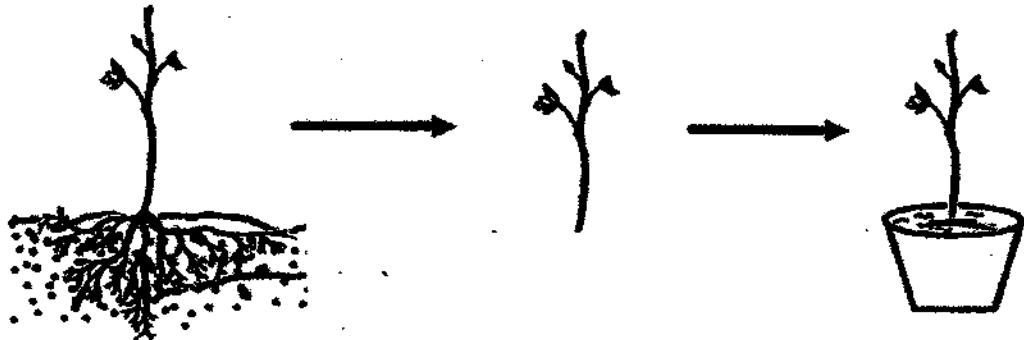

- a) Based on the pictures, which part of the plant was missing after the plant was taken out of the soil? (1 mark)

- b) What will happen to the plant a week later? (1 mark)

- c) Explain your answer in part (b). (1 mark)

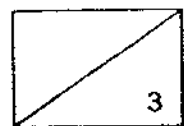

36. Two stalks of sunflower were cut in two different ways as shown below. Each stalk was put into a beaker of 300ml of water with 50ml of red colouring added. Both beakers were left at the same location.

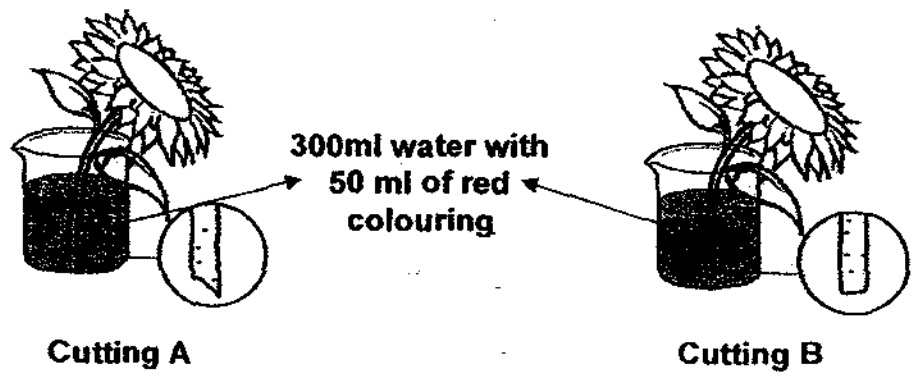

a) After one day, the amount of water remaining in each beaker was as shown in the table below.

	<i>Cutting A</i>	<i>Cutting B</i>
Amount of red coloured water remaining in the beaker	300 ml	325 ml

From the table above, which cutting, A or B, took in more water? (1 mark)

Cutting _____

b) Other than observing the change in the water level in each beaker, how else can we determine which stalk had taken in more water? (1 mark).

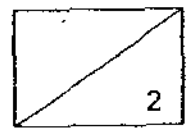

- c) Linda repeated the experiment for both cuttings. She replaced the sunflowers with plastic flowers. The plastic flowers were of the same size, shape and weight. Each stalk was also put into a beaker of 300ml of water with 50ml of red colouring added. Both beakers were then left at the same location.

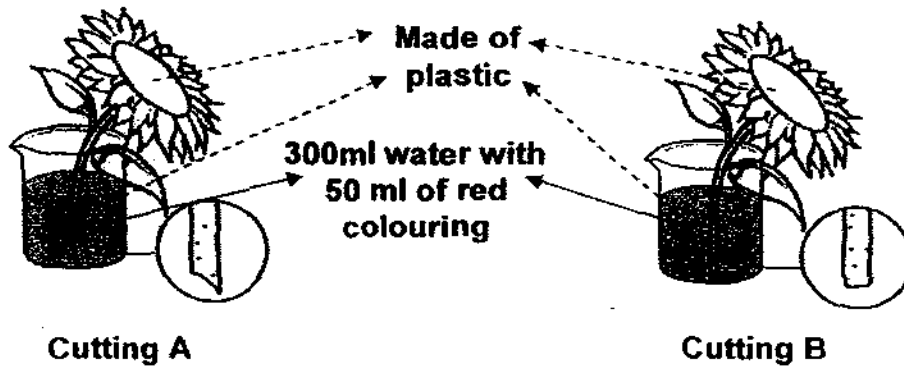

What will happen to the amount of water remaining in the beakers after one day? (1 mark)

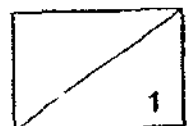

37a) Label the skeletal system using the words in the box below. (1 mark)

Rib cage Backbone Hip bone Skull

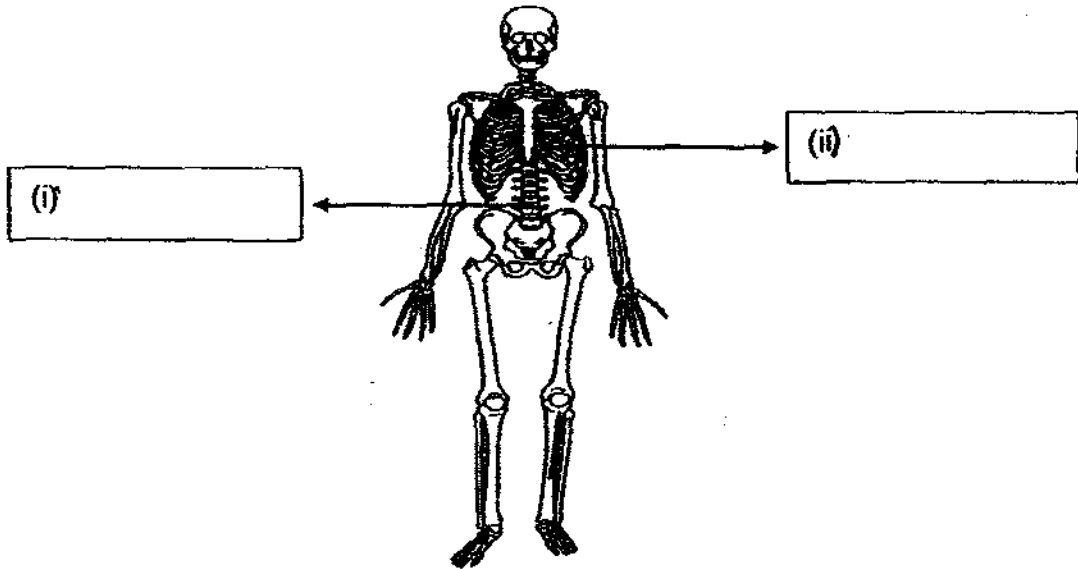

b) What is the function of the rib cage? (1 mark)

c) What happens when the skeletal system and the muscular system work together? (1 mark)

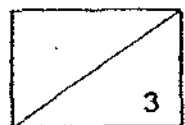

38. Three different materials, D, E and F were dipped into a container of coloured water at the same time. The materials are of the same size and thickness. The diagram below shows the amount of water absorbed by the different materials after 10 minutes.

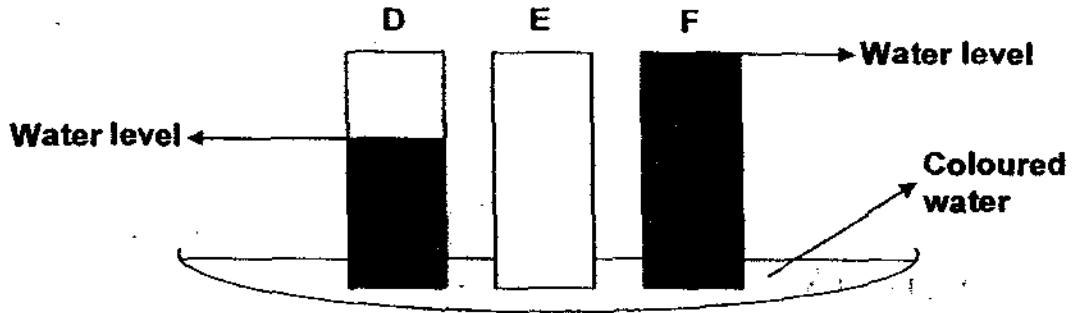

- a) Based on the result, what can you conclude about material F? (1 mark)

- b) What materials could D and E be if F is a piece of cotton cloth? Write the letters (D and E) into the correct box below. (1 mark)

<i>Paper</i>	<i>Plastic</i>	<i>Cotton Cloth</i>
		F

- c) Which material, D, E or F is most suitable for making a camping tent? Explain your answer. (1 mark)

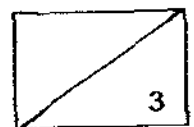

39.

A: Safety pin



B: Copper coin



C: Thumb tack



D: Aluminium foil

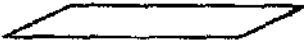

E: Eraser



F: Plastic ruler



Fill in the following table accordingly using the letters, A, B, C, D, E and F. Use each letter only once. (2 marks)

Objects that will be attracted by a magnet	Objects that will not be attracted by a magnet

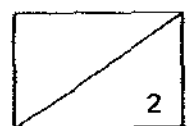

40a) Jane used a magnet to attract some iron filings. First, she placed a piece of paper between the magnet and the tray of iron filings as shown in Set-up A. Next, she removed the piece of paper so that the magnet is just above the tray of iron filings as shown in Set-up B.

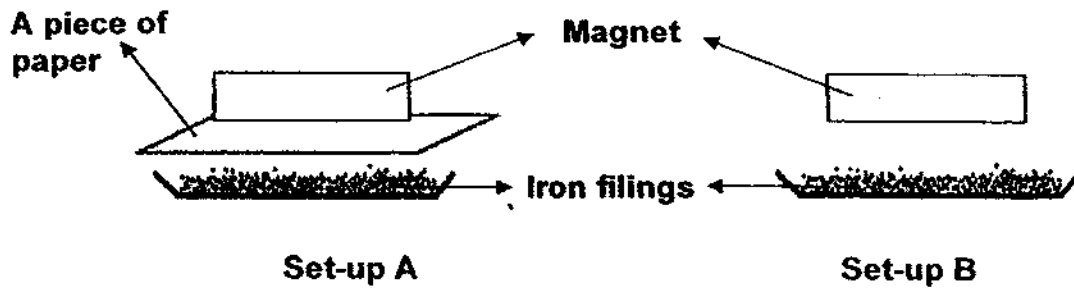

- i) Jane found out that the magnet attracted the same amount of iron filings in both set-ups. What does this experiment tell us? (1 mark)

- ii) What material could be used to replace the piece of paper to get the same result mentioned in Part (i)? (1 mark)

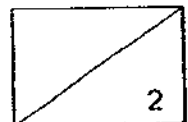

- b) In another experiment, Jane placed a magnet a distance away from a paper clip as shown below. The paper clip could still be attracted to the magnet.



The magnet was strong enough to attract the paper clip even though it did not touch the paper clip. Explain why. (1 mark)

41. 20g-weights were added one at a time on three similar strings, A, B and C until each string broke. The observations were recorded in the table below.

<i>String</i>	<i>Number of 20g-weights added</i>
A	6
B	8
C	3

- a) Arrange the strings in terms of their strength from the weakest to the strongest. (1 mark)
-
- b) Which string could be used to tie a 150g object without breaking the string? (1 mark)

String _____

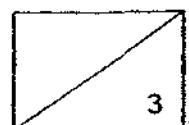

42. The following is a set-up to magnetise a steel rod as shown below.

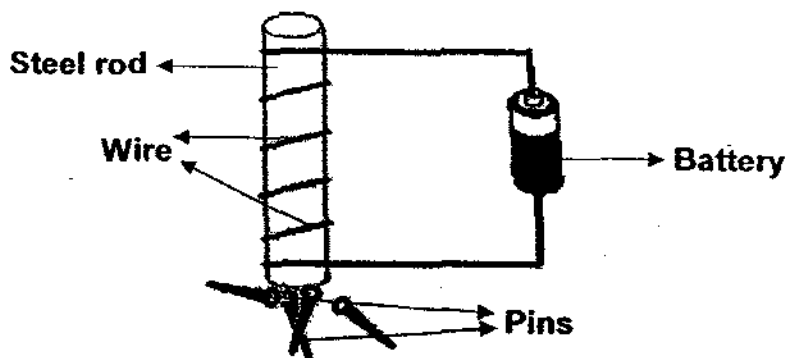

Four similar steel rods, W, X, Y and Z were used. Different results were observed when the number of turns of the wire on the steel rod changed.

Steel rod	Number of turns of wire on the steel rod	Number of pins attracted
W	10	2
X	13	5
Y	18	9
Z	25	13

a) Which steel rod has the greatest number of pins attracted? (1 mark)

Steel rod _____

b) What conclusion does this experiment tell you about the strength of an electromagnet? (1 mark)

c) Besides changing the number of turns of wire around the steel rod, write down one other way to produce a stronger magnet. (1 mark)

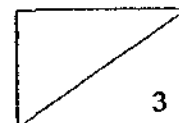

- d) Mr Tan replaced the pins with erasers. Would the erasers be attracted? Why? (1 mark)

43. The four items in the table below were put into a tank of water. They were then classified into the two groups based on their behaviour in the tank of water.

<i>Group A</i>	<i>Group B</i>
Rubber toy duck Empty plastic bottle	Safety pin Copper coin

- a) Write a suitable heading for each group. (1 mark)

A: _____

B: _____

- b) The table below shows the properties of three materials.

<i>Material</i>	<i>Waterproof</i>	<i>Breaks easily</i>	<i>Floats on water</i>
X	√	X	√
Y	√	√	X
Z	X	√	√

- i) Describe Material Y using all the properties listed above. (1 mark)

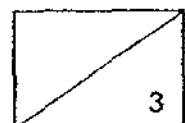

- ii) Which material (X, Y or Z) is the most suitable material for making a water bottle? Explain your answer. (1 mark)

44. A bar magnet was lowered into a tray of iron nails as shown below.

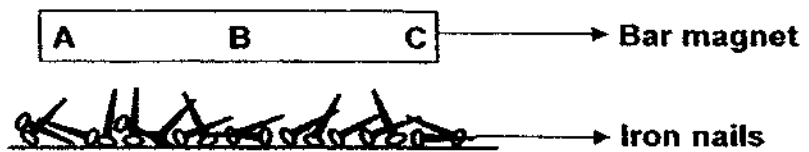

- a) Which part(s), A, B or C will attract more iron nails? (1 mark)

- b) Explain your answer for part (a). (2 marks)

End of Section B
Please check your answers.

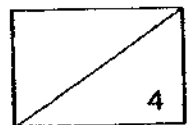

ANSWER SHEET

EXAM PAPER 2009

**SCHOOL : RED SWASTIKA PRIMARY
SUBJECT : PRIMARY 3 SCIENCE**

TERM : SA2

Q1	Q2	Q3	Q4	Q5	Q6	Q7	Q8	Q9	Q10	Q11	Q12	Q13	Q14	Q15	Q16	Q17
3	4	1	1	2	3	3	4	4	3	1	2	4	1	4	3	4

Q18	Q19	Q20	Q21	Q22	Q23	Q24	Q25	Q26	Q27	Q28	Q29	Q30
3	3	4	2	1	1	2	1	1	4	3	4	4

31) a) i) A: lay eggs ii) gave birth
b) i) B ii) A

32) a)



b) It can hold the leaf upright to get more sunlight.
c) It is for making food for the plant.

33) a) It belongs to insects.
b) i) They both have three pairs of legs.
ii) The bee has a pair of wings but an ant does not have a pair of wings.

34) a) i) stomach b) large intestine
b) Digestive juices.
c) X.

35) a) It is the roots.
b) The plant will die a week later.
c) The roots help the plant firmly to the ground and to take in water and mineral salt to all parts of the plant.

- 36) a) A.
 b) We should observe which stalk were turned reddish.
 c) It will remain the same.
- 37) a) i) backbone ii) Rib cage
 b) To protect our heart and lungs.
 c) We can move.
- 38) a) It absorbed most of the coloured water.
 b) D, E
 c) E. It is waterproof.
- 39) C, A. B, D, E, F
- 40) a) i) This experiment fell as that magnet force through a piece of paper.
 ii) It is cotton.
 b) Magnetic can attract from a distance.
- 41) a) String C, String A, String B.
 b) B.
- 42) a) Z.
 b) The strength of the electromagnet increase with the number of turns of wire on the steel iron.
 c) It should put more battery.
 d) No. It is not a magnetic.
- 43) a) A: Things that float.
 B: Things that sink.
 b) i) Material Y is waterproof, break easily and does not float on water.
 ii) It is material X. It is waterproof, does not break easily and it float on water.
- 44) a) A and C will attract more iron nails.
 b) A and C is north-south pole so the north-south pole is the strongest pole of the magnet so it will attract more iron nail.