

Name: \_\_\_\_\_ ( )

Class: Primary 4 \_\_\_\_\_

## CHIJ ST NICHOLAS GIRLS' SCHOOL

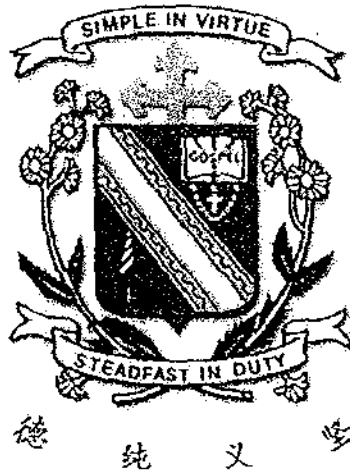

**Primary 4**

**First Continual Assessment – 2009**

**SCIENCE**

**BOOKLET A**

**4<sup>th</sup> March 2009**

**Total Time for Booklets A and B: 1 hour 30 minutes**

**30 questions  
40 marks**

**Do not open this booklet until you are told to do so.  
Follow all instructions carefully.  
Answer all questions.**

**Section A : ( 30 x 2 MARKS )**

For each question from 1 to 20, 4 options are given. One of them is the correct answer. Make your choice (1, 2, 3 or 4). Shade the correct answer (1, 2, 3 or 4) in the Optical Answer Sheet (OAS) provided.

1. Which one of the following animals has a life cycle like the one shown below?

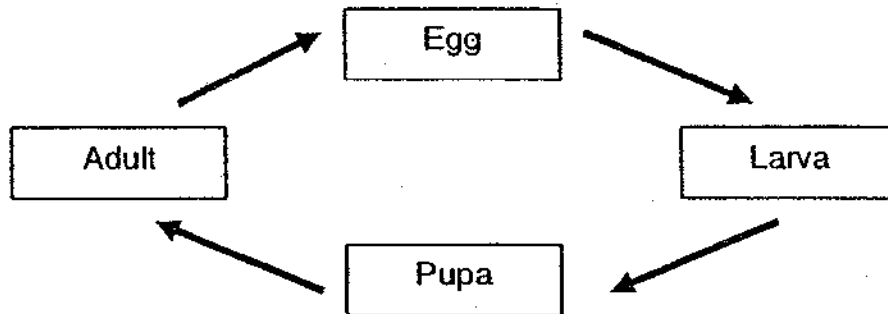

- (1) Cockroach and Butterfly  
(2) Grasshopper and Mosquito  
(3) Mealworm and Chicken  
(4) Mosquito and Butterfly
2. Which are the conditions needed for the seeds to grow into a seedling.
- A) Air  
B) Light  
C) Water  
D) Warmth
- (1) A only  
(2) A and B only  
(3) B, C and D only  
(4) A, C and D only
3. Jamie decides to wait and observe a chicken egg to find out if it has been fertilised after she had witnessed a chicken laid it. He put the egg in an incubator. How long should she wait to get her answer?
- (1) 2 days  
(2) 2 weeks  
(3) 21 days  
(4) 21 weeks

4. Which one of the following shows the stages of development of a bean seed when it germinates?

- (1) Seed → Root → Green leaves
- (2) Seed → Leaves → Roots
- (3) Seed → Root → Seed Leaves
- (4) Seed → Seed Coat → Seed Leaves

5. Below are some opinions of four children about their understanding about seeds.  
*whose opinion is <sup>is</sup> correct?*

Names of children	Opinions
Karlyn	All plants have seeds.
Jenny	Flowering plants have seeds.
Tammy	Only green plants have seeds.
Shanice	Only trees have seeds.

- (1) Karlyn only
- (2) Jenny only
- (3) Karlyn and Jenny only
- (4) Tammy and Shanice only

6. Pamela did a study on two animals, X and Y. She wrote her observation as shown below.

Observation	Animal X	Animal Y
Eggs are laid in water	X	✓
There are 3 stages in the life cycle.	X	✓
It has six legs.	✓	X
Its young looks like its adult.	X	X

Which one of the following names Animals X and Y correctly?

	Animal X	Animal Y
(1)	Beetle	Frogs
(2)	Butterfly	Mosquito
(3)	Chicken	Guppy
(4)	Grasshopper	Duck

7. Look at the picture below.

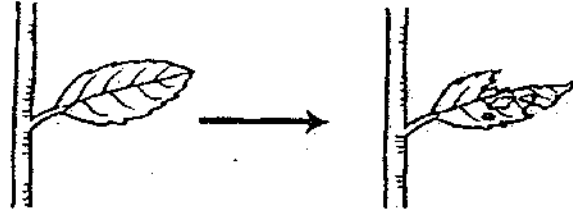

The change in the leaf is caused by an animal. Name the stage of the animal that could have caused the change in the leaf.

- (1) Egg
- (2) Larva
- (3) Pupa
- (4) Adult

8. Which one of the following is the life cycle of grasshopper correctly drawn?

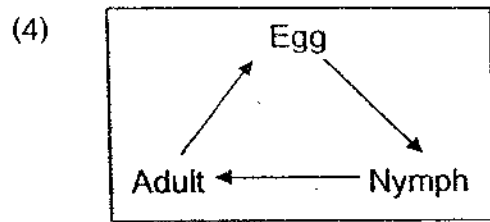
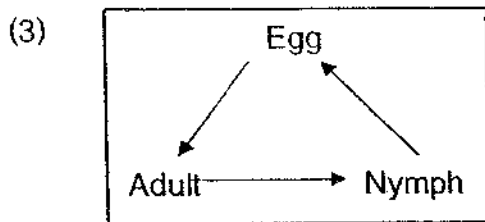
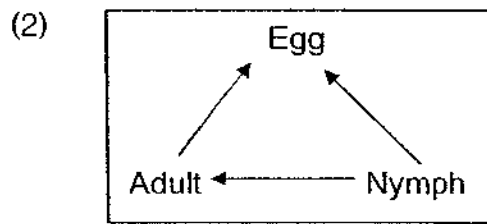
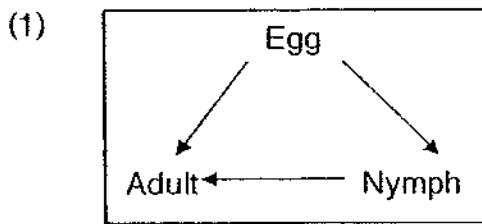

9. Below are some views of four children about their understanding about eggs.

*Whose opinion is the correct?*

Names of children	Opinions
Alice	All eggs will grow into young animals.
Belle	All eggs have shells.
Janice	Only fertilised eggs will grow into young animals.
Zoe	Only birds lay eggs.

- (1) Alice only
- (2) Zoe only
- (3) Janice only
- (4) Janice and Zoe only

10. Study the classification diagram carefully.

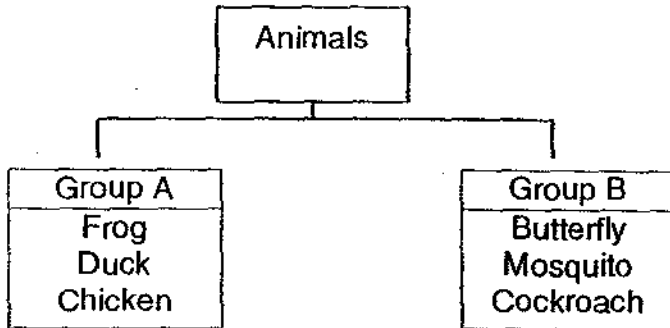

Which one of the animals above is in the wrong group in terms of the number of stages in their life cycles?

- (1) Duck
- (2) Butterfly
- (3) Cockroach
- (4) Chicken

11. Look at the diagram shown below carefully.

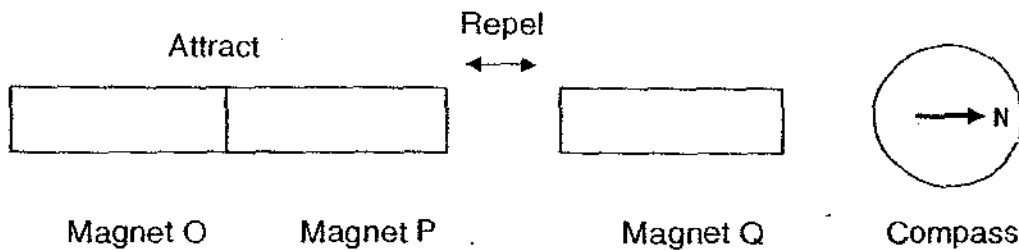

When the three magnets are placed near one another, Magnet O and Magnet P attract each other but Magnet P and Magnet Q repel each other. Which one of the diagrams shows the correct poles for Magnet P and magnet Q?

- (1) Magnet P: S N      Magnet Q: N S
- (2) Magnet P: N S      Magnet Q: S N
- (3) Magnet P: S N      Magnet Q: S N
- (4) Magnet P: N S      Magnet Q: N S

12. Study the experimental set-up below carefully.

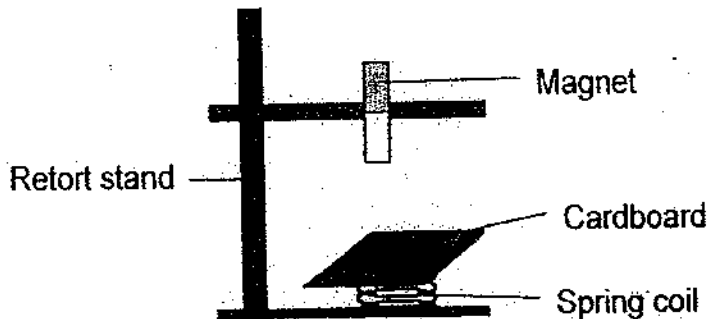

Jasmine used the above set-up to test four different objects S, T, U and V by taping them on a piece of cardboard as shown above. She recorded her observation as shown below.

Object	Length of spring
S	No change
T	Extended
U	Extended
V	Compressed

Based on the observations above, what could be the objects S, T, U and V.

	S	T	U	V
(1)	Iron nail	Steel cup	Magnet	Eraser
(2)	Plastic cup	Magnet	Steel cup	Eraser
(3)	Magnet	Steel paper clip	Iron nail	Plastic cup
(4)	Plastic cup	Iron nail	Steel paper clip	Magnet

13. Which one of the following objects is made from **once alive** material?

- (1) Silk tie
- (2) Leather belt
- (3) Porcelain vase
- (4) Magnetic whiteboard

14. Marianne conducted an experiment as shown below. The metal clip was found floating in the air. What could be the reason for the metal clip to remain in the air?

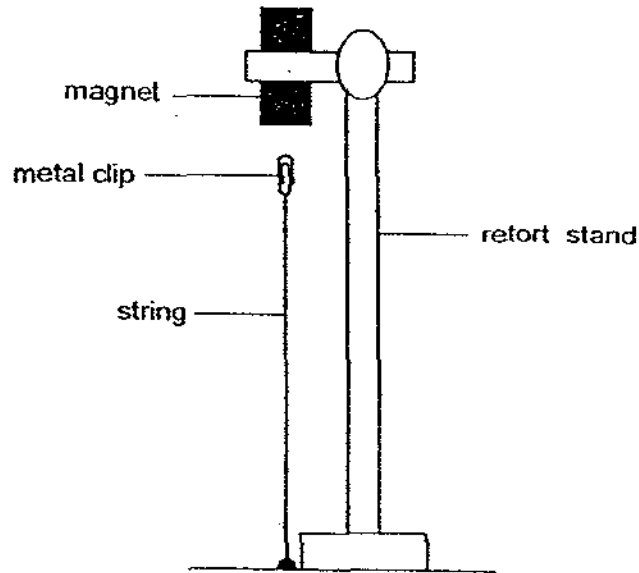

- (1) The magnet is attracting the metal clip.
  - (2) The metal clip is attracting the magnet.
  - (3) The magnet is repelling the metal clip.
  - (4) The metal clip is repelling the magnet.
15. Look at the diagram below and state the similarity between an ant and a ladybird.



Ant



Ladybird

- (1) Both can fly.
- (2) Both can lay eggs.
- (3) Both have eight legs.
- (4) Both have three body parts.

16. Below are some descriptions of micro-organisms from four children. Whose description(s) is/are true?

Names of children	Opinions
Alvin	They are also called germs.
Calvin	They only spread diseases.
Joshua	They can only spread by sneezing.
Ahmad	They can only be seen using a microscope

- (1) Calvin only  
(2) Ahmad only  
(3) Alvin and Calvin only  
(4) Ahmad and Joshua only
17. Which one of the following statements explains why fungi are not classified as plants?
- (1) Fungi reproduce by spores  
(2) Fungi cannot grow big in size.  
(3) Fungi do not have chlorophyll.  
(4) Fungi do not need a lot of light to grow.
18. The door of the refrigerator is designed to prevent the cool air from escaping from within. What is used to enable the door to do its function.
- 1) Rubber strip  
2) Magnet strip  
3) Plastic handle  
4) Aluminium handle
19. Which one of the following is **not** true?
- (1) All animals have legs.  
(2) Animals feed on different kinds of food.  
(3) Different animals have different outer coverings.  
(4) Animals reproduce to prevent their kind from extinction.

20. Study the diagram below. Which one of the set-up will be the strongest electromagnet?

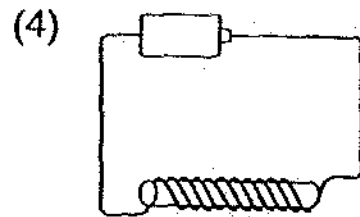
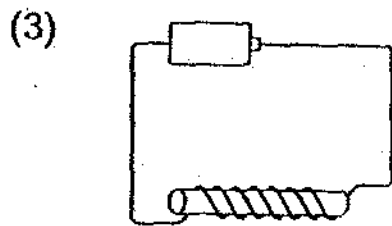
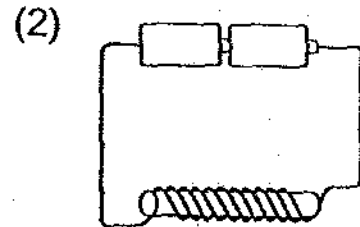
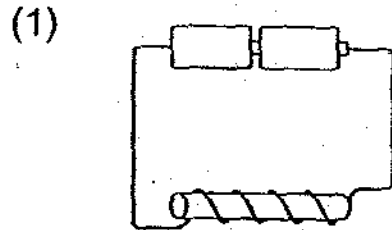

21. Which one of the following statements about magnets is/are **correct**?

- A) Lodestones are natural magnets.
- B) A round magnet does not have any poles.
- C) A mixture of copper wires and iron nails can be separated by using a magnet.
- D) The compass needle always points to the North direction.

- (1) A and B only
- (2) A, B and C only
- (3) A, C and D only
- (4) A, B, C and D

22. Where does the water taken in by the roots of plants go to?

- A) Fruits
- B) Stems
- C) Leaves
- D) Flowers

- (1) A only
- (2) A and B only
- (3) B, C and D only
- (4) A, B, C and D

23. Which of the following names below classify broad groups of living things correctly.

- (1) Animals, mammals, fish and plants.
- (2) Animals, bacteria, fungi and plants.
- (3) Mammals, fungi, mushrooms and plants.
- (4) Micro-organisms, fungi, bacteria and plants.

24. The diagrams below show four human body systems. Which two systems enable us to move when work together?

A:

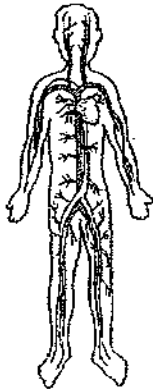

B:

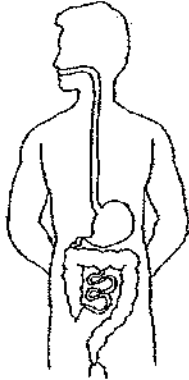

C:

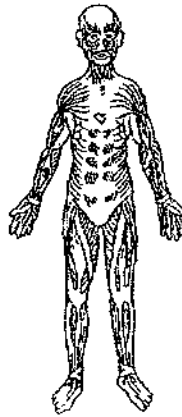

D:

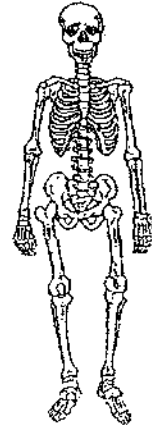

(1) A and B

(2) A and C

(3) B and D

(4) C and D

25. Study the diagram below carefully and state what happens when our arm is bent?

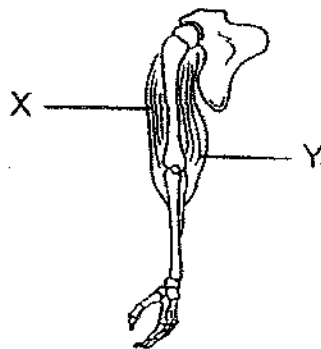

- (1) Both X and Y relax.
- (2) Both X and Y contract.
- (3) X relaxes and Y contracts.
- (4) X contracts and Y relaxes.

26. What is system A in the diagram as shown below.



- (1) Skeletal system
- (2) Digestive system
- (3) Circulatory system
- (4) Respiratory System

27. Sally observed an animal and recorded her observation in her notebook. It reads, "Animal Z has webbed feet. It lays eggs and it has hair on its body."

From the above description, which group of animals does animal Z belong to?

- (1) Bird
- (2) Fish
- (3) Insect
- (4) Mammal

28. Study the classification chart below.

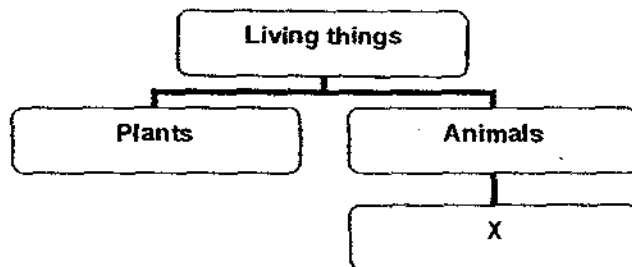

Which one of the things listed below can be filled in the box marked 'X'?

- (1) Bird nest
- (2) Toadstool
- (3) Grasshopper
- (4) Zebra crossing

29. Jane did an experiment to find out the properties of an object. She dropped it on the floor and it changed its shape but it did not break. She could knead the object back to its original shape with her hands. What was the object she was testing?

- (1) Eraser
- (2) Plasticine
- (3) Table tennis ball
- (4) Plastic water bottle

30. Bernice planted some bean seeds and recorded her observations as shown below.

Number of days	Observations
Day 1	Nothing happens
Day 2	Nothing happens
Day 3	Nothing happens
Day 4	Nothing happens

Why are the seeds **not** germinating?

- (1) Bernice did not water the seeds.
- (2) Bernice did not provide light to the seeds.
- (3) Bernice had used an opaque plastic container.
- (4) Bernice had used tissue paper instead of cotton wool.

- End of Section A -

Name: \_\_\_\_\_ ( )

Class: Primary 4 \_\_\_\_\_

## CHIJ ST NICHOLAS GIRLS' SCHOOL



**Primary 4**

**First Continual Assessment – 2009**

**SCIENCE**

**BOOKLET B**

**4<sup>th</sup> March 2009**

**Total Time for Booklets A and B: 1 hour 30 minutes**

**14 questions  
30 marks**

Booklet A	60
Booklet B	40
Total	100

**Do not open this booklet until you are told to do so.  
Follow all instructions carefully.**

\_\_\_\_\_  
Parent's Signature/Date

**Section B : (40 marks)**

For questions 31 to 44, write your answers in this booklet. The number of marks is shown in [ ] at the end of each question or part question.

31. a) Complete the diagram below to show the life cycle of a cockroach. [2]

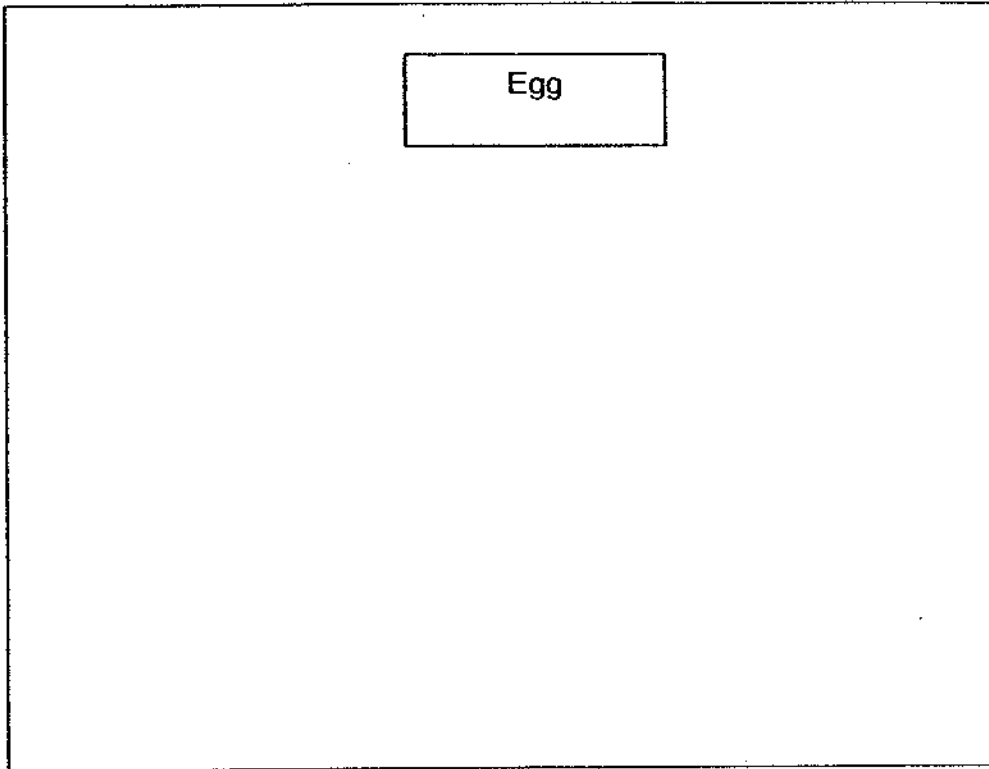

- (b) Cockroaches are pests. At which stage of its life cycle is it most difficult to kill the cockroaches? [1]

---

---

- (c) Explain your answer in (b). [1]

---

---



32. A magnet is used to pick up nail X. Nail Y is picked up too as shown in the diagram below.

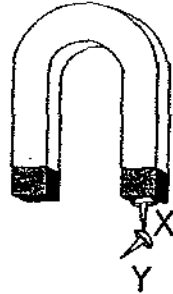

Explain how nail X is able to lift nail Y.

[2]

---

---

---

33. Study the diagram below.

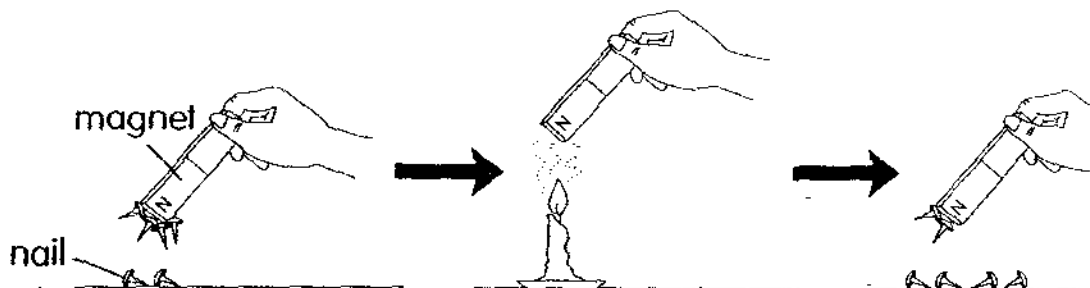

What does the above experiment show about the magnet?

[1]

---

---



34. The diagram below shows one of the magnets that had dropped and broken into two pieces, X and Y.

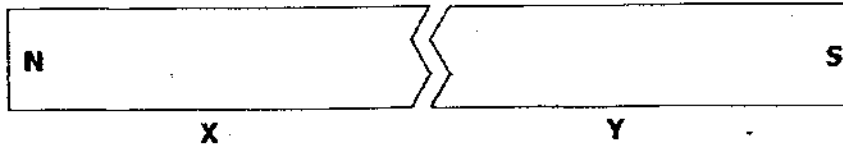

This is what happens when magnet X is brought to magnet R.

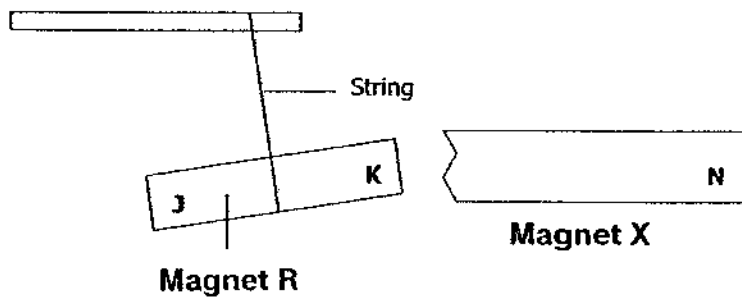

Name the poles with the letter 'N' (for North pole) or 'S' (for South pole) in the blanks. [2]

- (i) J : \_\_\_\_\_ (ii) K : \_\_\_\_\_

35. Shireen was given a magnet and an object. How can she prove that the object is also a magnet? [4]

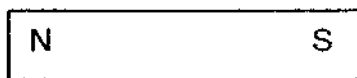

Magnet

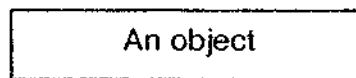

---



---



---



---



---



36. Sharon sets up an experiment as shown below. The nail can attract some paper clips.

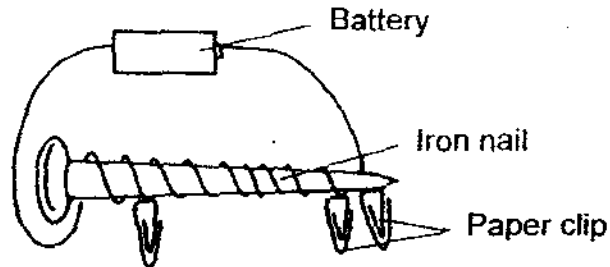

- (a) Name the method of making the nail into a magnet. [1]

\_\_\_\_\_

- (b) Name the material used to make the paper clips. [1]

\_\_\_\_\_

- (c) What can Sharon do to the set-up above to make the nail to attract more paper clips? [1]

\_\_\_\_\_

\_\_\_\_\_

37. The diagram below shows a stack of four bar magnets.

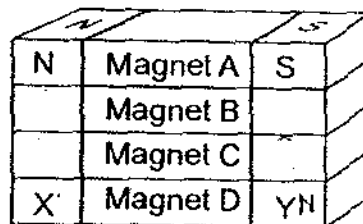

- (a) What are poles X and Y of Magnet D? [2]

X: \_\_\_\_\_ Y: \_\_\_\_\_

- (b) Which type(s) of magnetic force is/are demonstrated in the diagram above? [1]

\_\_\_\_\_

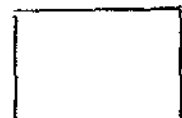

38. Study the classification chart below.

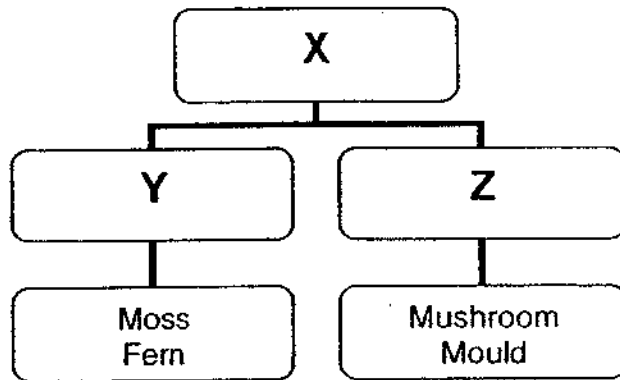

Based on the chart above, write appropriate headings for the following:

- i) X: \_\_\_\_\_
- ii) Y: \_\_\_\_\_
- iii) Z: \_\_\_\_\_

[3]



39. Mariam conducted an experiment as shown below with an iron bar using magnet X as shown below.

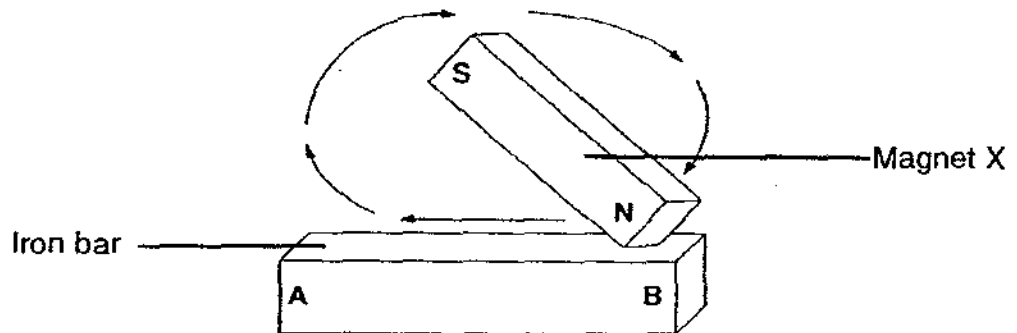

- (a) Name the poles A and B of the iron rod after some time. [1]

A: \_\_\_\_\_

B: \_\_\_\_\_

- (b) Describe what Mariam should do to increase the magnetic force of the iron bar in the same experiment as shown in the diagram above. [2]

\_\_\_\_\_

\_\_\_\_\_

\_\_\_\_\_

\_\_\_\_\_



40. Study the diagram below carefully.

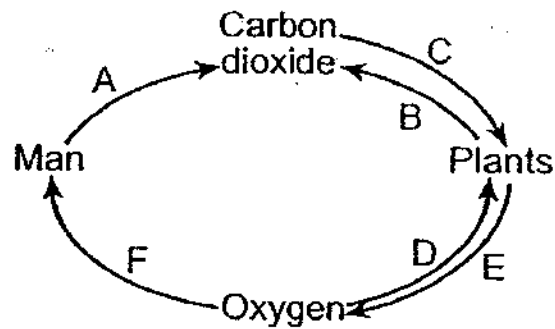

Arrows A, B, C, D, E, F show exchanges of gases between living things and their surrounding.

a) Name the processes taking place shown by the following arrows,

i) A, C & E: \_\_\_\_\_

ii) D & B: \_\_\_\_\_ [1]

b) State when the process named in (i) happens. [1]

\_\_\_\_\_

c) State when the process named in (ii) happens. [1]

\_\_\_\_\_



41. The diagram below shows the germination process of a bean.

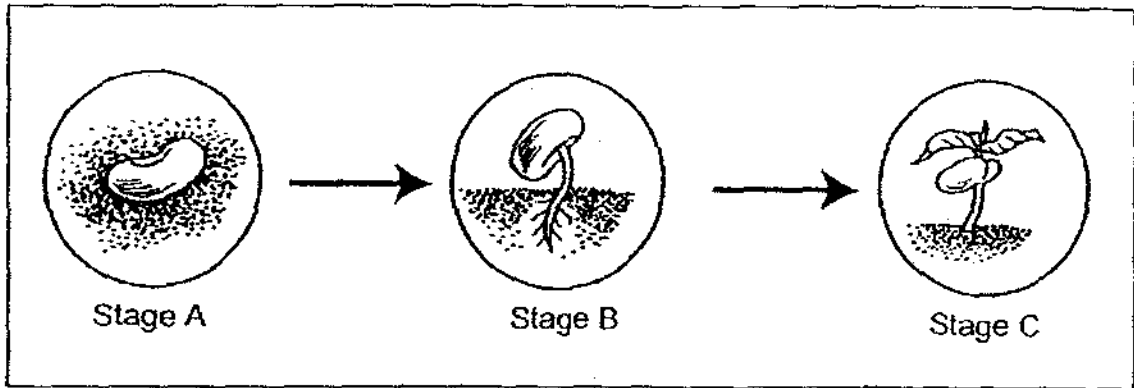

- a) At stage B, where does the young seedling get its food from? [1]

\_\_\_\_\_

- b) At which stage, A, B or C will the seed be able to make its own food? [1]

\_\_\_\_\_

- c) At which stage, A, B or C will the seed need light energy to grow? [1]

\_\_\_\_\_



42. The diagram below shows the life cycles of a plant and an animal.

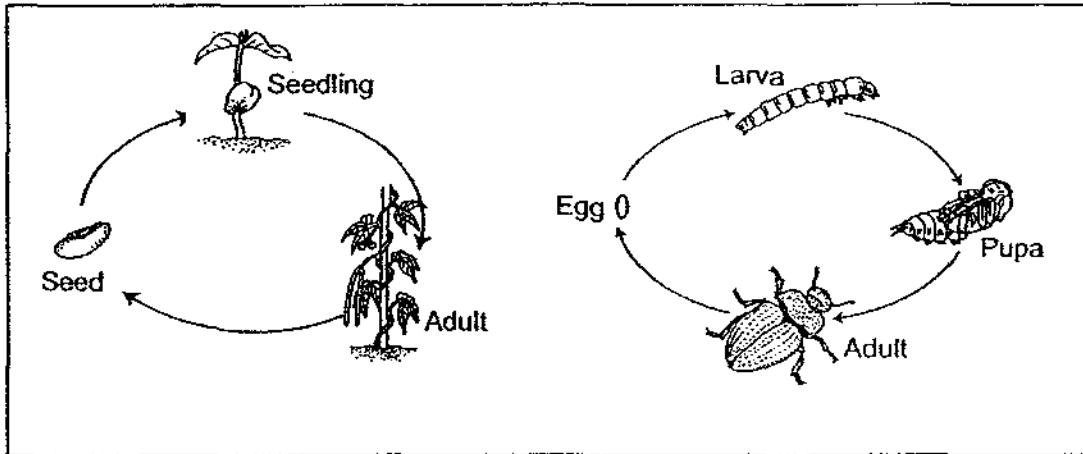

a) Based on the above diagram, state 2 differences between the life cycle of a plant and an animal. [2]

Difference 1: \_\_\_\_\_  
 \_\_\_\_\_  
 \_\_\_\_\_

Difference 2: \_\_\_\_\_  
 \_\_\_\_\_  
 \_\_\_\_\_

b) Explain why both plants and animals need to reproduce. [1]

\_\_\_\_\_  
 \_\_\_\_\_



43. Four iron nails labelled A, B, C and D were attracted to a bar magnet as shown below.

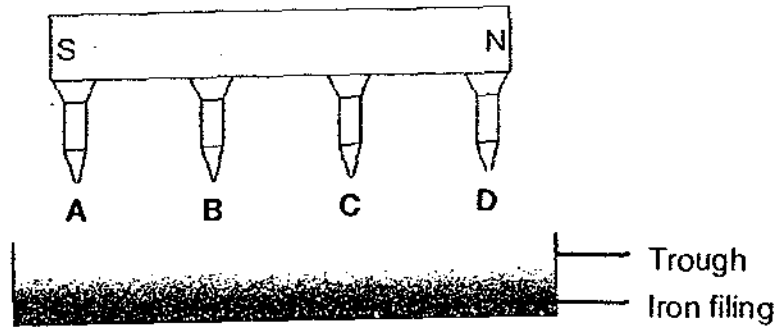

- a) Describe how to prove which part(s) of the magnet has/have the strongest magnetic force? [2]

---

---

---

---

---

- b) Which nail(s), A, B, C and D is/are able to attract the largest amount of iron filing? [1]

---



44. Study the diagram carefully.

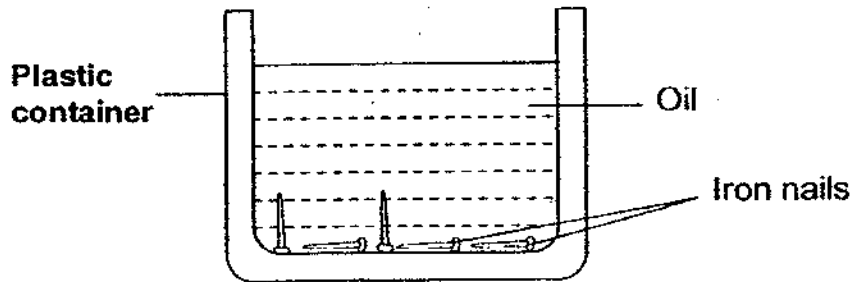

Ashley wanted to take the nails out of the container without getting her hands oily.

- a) What can she use to take the nails out? [1]

- b) Explain your answer in (a). [2]

---

---

---

--- End of Paper ---

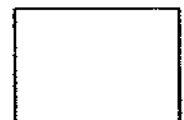

# ANSWER SHEET

EXAM PAPER 2009

SCHOOL : CHIJ PRIMARY SCHOOL  
SUBJECT : PRIMARY 4 SCIENCE

TERM : CA 1

Q1	Q2	Q3	Q4	Q5	Q6	Q7	Q8	Q9	Q10	Q11	Q12	Q13	Q14	Q15	Q16	Q17
4	4	3	3	2	1	2	4	3	3	2	4	2	1	2	2	3

Q18	Q19	Q20	Q21	Q22	Q23	Q24	Q25	Q26	Q27	Q28	Q29	Q30
2	1	2	3	4	2	4	4	4	4	3	2	1

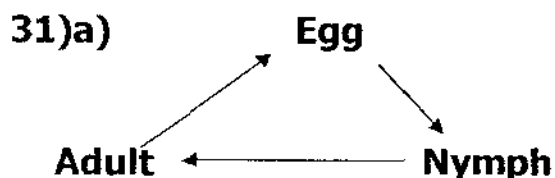

- b) It is most difficult to kill the cockroach at the adult stage.  
c) The cockroach can crawl and fly at the adult stage.

32) The magnetic force from the magnet passes through Nail X and the magnet attracts Nail Y too.

33) The magnetic force of the magnet became weaker when heated.

34) i) S ii) N

35) Use both the ends of the object to attract the magnet. If one end attracts and the other end repels, then the object is a magnet.

36) a) The electrical method.

b) Iron.

c) Sharon can add more batteries or make more coils around the nail.

37) a) X: South pole      Y: North pole  
b) The force of attraction.

38) i) Living things.  
ii) Non-flowering plants.  
iii) Fungi.

39) a) A: South pole      B: North pole  
b) Mariam should stroke the iron bar more times in the same direction.

40) a) i) Photosynthesis.      ii) Respiration.  
b) Photosynthesis happened when there is light.  
c) Respiration happens all the time.

41) a) It gets its food from the seed.  
b) The seed will be able to make its own food at stage C.  
c) It needs light energy to grow at stage C.

42) a) 1) The plant grows from seed whereas the animal grows from eggs.  
2) The animal grows from eggs but the plant grows from seeds.  
b) They reproduce to make sure that their own kind continue to be on Earth and also prevents.

43) a) Lower the magnet with the nails until the nails attract some iron filing. Raise the magnet with the nails, and observe with nails attracted the most amount of iron filing.  
b) Nails A and D will attract the largest amount of iron filing.

44) a) She can use a magnet to take the nails out.  
b) The magnetic force of the magnet can pass through non-magnetic material and attract the iron nails in the plastic container.