

Pei Chun Public School  
Semestral Assessment 1 – 2009  
Science  
Primary 4

Name : \_\_\_\_\_ ( )

Date : 15 May 2009

Class : Pri..4 ( )

Science Teacher : \_\_\_\_\_

Time : 1 h 30 min

**Section A (25 × 2 marks)**

For questions 1 to 25, choose the most suitable answer and shade its number (1, 2, 3 or 4) on the Optical Answer Sheet (OAS) provided.

1. Study the diagrams below.



morning glory



hibiscus

Based on the diagrams, which of the following statements about the two living things are definitely true?

- A Both plants have lobed leaves.
- B Both flowers have five petals each.
- C Both plants have purple coloured flowers.
- D The morning glory has a weak stem while the hibiscus has a strong stem.

- (1) A and B only
- (2) A and D only
- (3) B and C only
- (4) C and D only

( )

2. Which of the following is not true about roots?

- They take in mineral salts.
- They hold the plant upright.
- They take in water from the soil.
- They hold the plant firmly to the soil.

( )

3. Study the two groups of animals below.

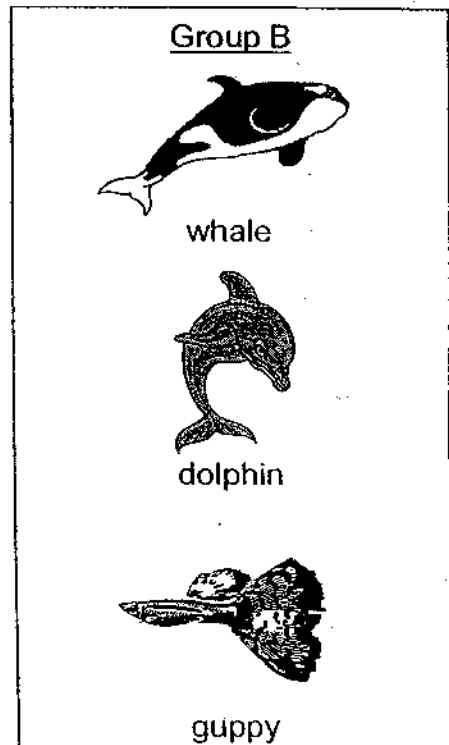
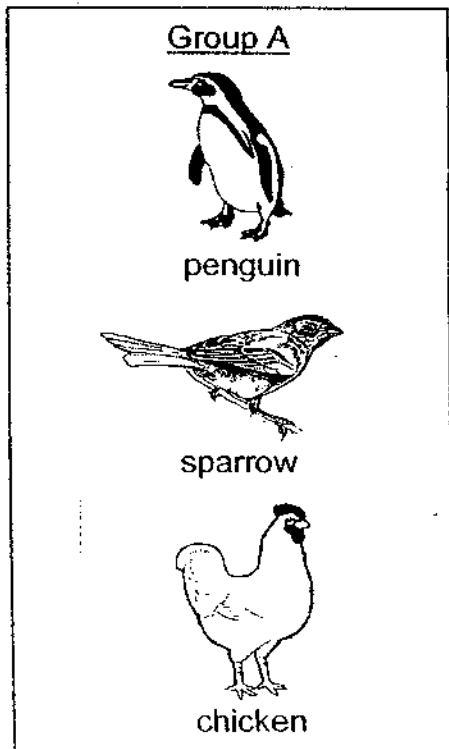

They are classified according to \_\_\_\_\_.

- the way they reproduce
- how they move
- where they live
- what they eat

- A and B
- A and C
- B and D
- C and D

( )

4. Four identical magnets were placed under different conditions as shown in the diagrams below. Which of them will remain strong after half an hour?

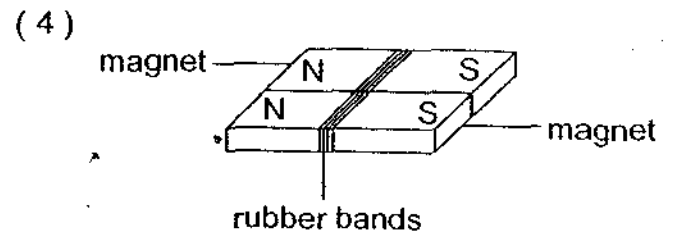
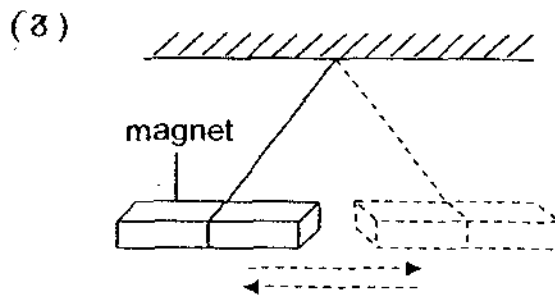
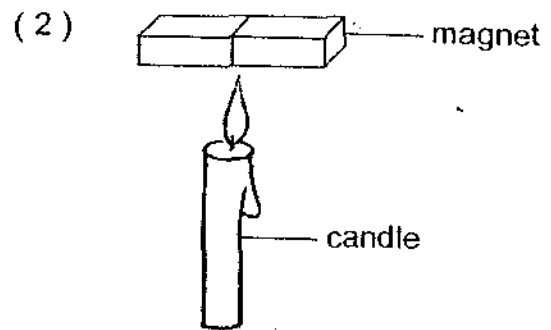
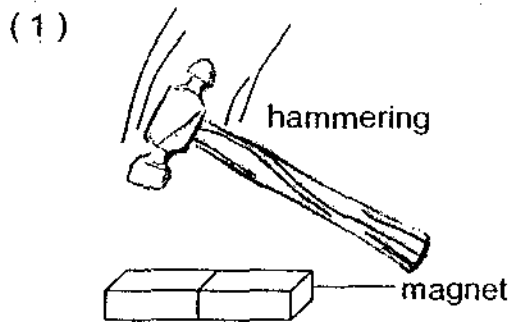

( )

5. Wei Han put a frog and a small dish of water into a clear glass container. He then replaced the lid and sealed it tightly. One week later, the frog in the container died.

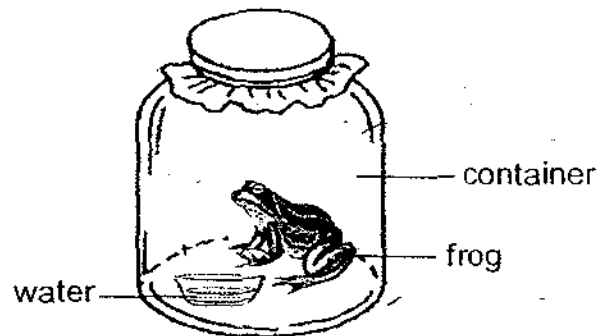

What were the possible reasons?

- A: There was not enough air in the container.
- B: There was not enough light in the container.
- C: There was not enough water in the container.
- D: There was no food for the frog in the container.

- (1) A and D only
- (2) B and C only
- (3) A, B and C only
- (4) A, C and D only

( )

6. Aeroplanes used to be made of wood. However, aeroplanes nowadays are made of a special type of aluminium.

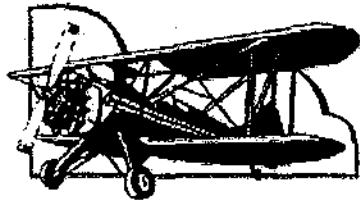

old aeroplane



new aeroplane

Which properties of aluminium make it a better choice than wood for making aeroplanes?

- A: Aluminium is lighter than wood.
- B: Aluminium is stronger than wood.
- C: Aluminium is more flexible than wood.
- D: Aluminium sinks in water whereas wood floats.

- (1) A and B only
- (2) B and D only
- (3) C and D only
- (4) A, B and C only

( )

7. Study the classification chart below.

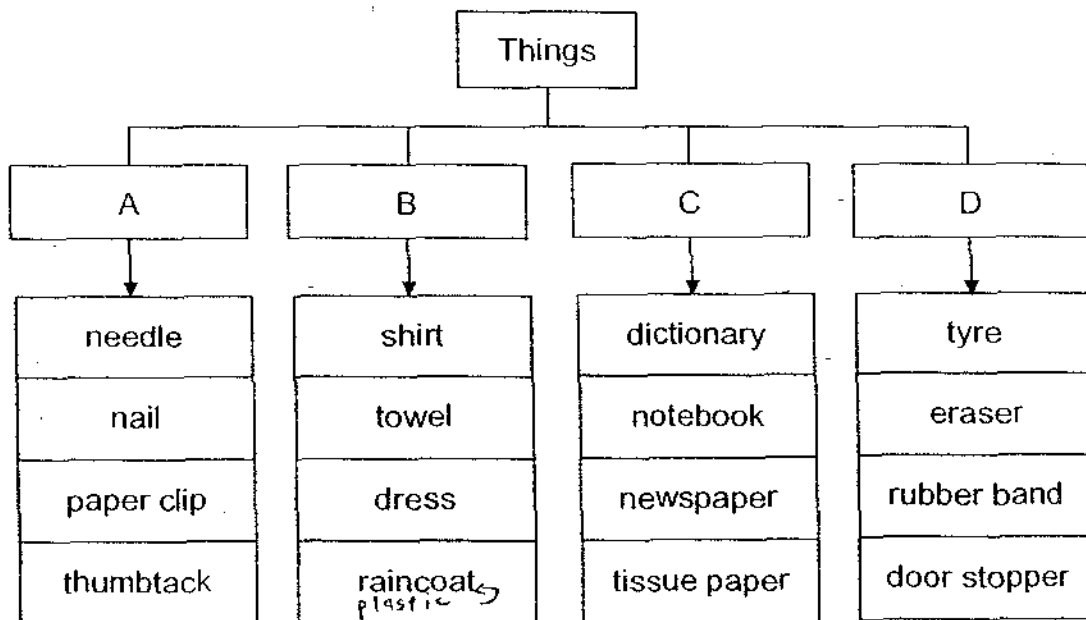

Which of the above items is classified wrongly?

- (1) paper clip
- (2) notebook
- (3) raincoat
- (4) tyre

( )

8. Four thin pieces of materials W, X, Y and Z of the same size, were weighed individually before they were put into the beakers of water shown.

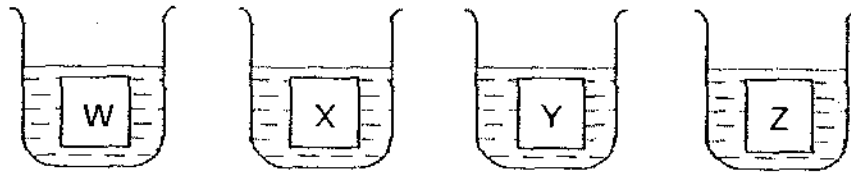

After 15 minutes, each piece was weighed again. Their masses were recorded in the table below.

Material	Mass at the beginning (g)	Mass after 15 minutes (g)
W	8	10 $\leftarrow \rightarrow$
X	10	20
Y	12	12
Z	13	18

Which material is the most suitable for making a disposable cup?

- (1) W
- (2) X
- (3) Y
- (4) Z

( )

9. Matthew used identical batteries, wires and iron bars to make four electromagnets as shown in the diagrams below. Which of them would attract the most number of pins?

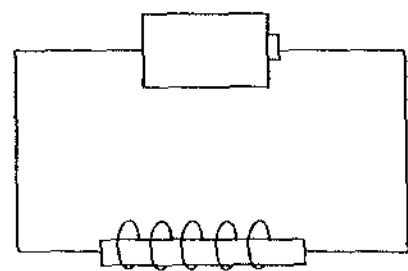
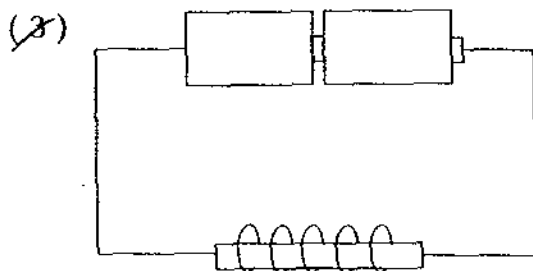
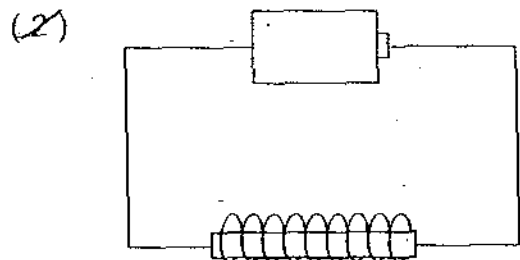
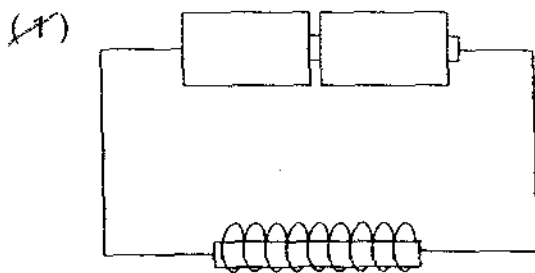

( )

10. Look at the two set-ups below.

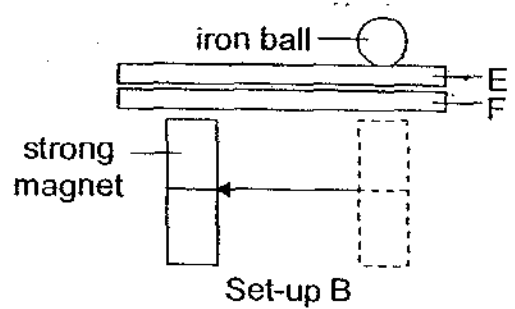
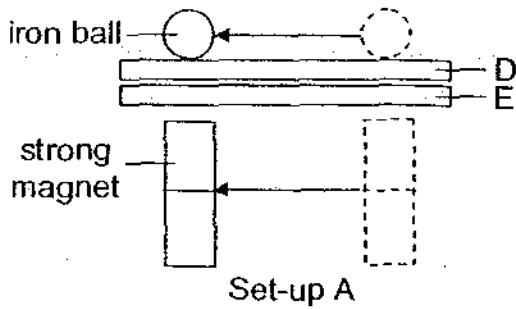

When Siti moved a strong magnet under materials D and E in set-up A, the iron ball moved in the same direction as the magnet.

However, when she moved the same magnet under materials E and F in set-up B, the iron ball did not move.

Which of the materials is/are definitely magnetic?

- E only
- F only
- D and E
- E and F

( )

11. Two iron nails are magnetised by a strong bar magnet as shown in the diagram below. G is one end of the magnet.

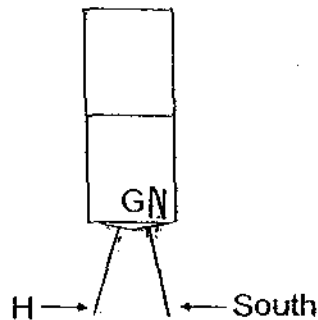

What are the poles of the parts marked G and H?

	G	H
(1)	North	South
(2)	North	North
(3)	South	South
(4)	South	North

( )

12. Look at the classification chart below.

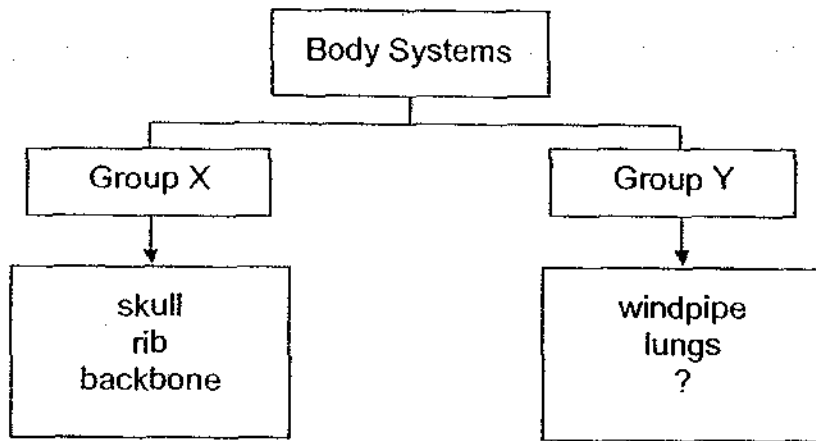

Which of the following is missing from the chart?

- (1) nose
- (2) heart
- (3) gullet
- (4) muscles

( )

13. Rahmat is singing and dancing. Which of the following systems is/are mainly responsible for his movements?

- A: skeletal
- B: digestive
- C: muscular
- D: circulatory

- (1) A only
- (2) A and B only
- (3) A and C only
- (4) B, C and D only

( )

14. Which of the following is/are matter?

- A: light
- B: heat
- C: wind
- D: shadow

- (1) C only
- (2) A and C only
- (3) B and D only
- (4) A, B and D only

( )

15. Gopal put a few drops of red ink into a beaker of water. He placed a white rose into the beaker as shown below.

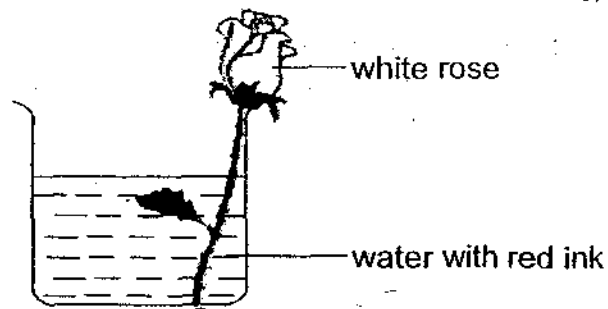

After a few hours, he noticed that the flower had turned red. The experiment showed that the coloured water was carried by the \_\_\_\_\_.

- (1) leaf to the flower
- (2) roots to the flower
- (3) stem to the flower
- (4) flower to the stem

( )

16. Jia Hao pumped air into a balloon. Then he squeezed the balloon in the middle as seen in the diagram.



Which of the following statements about air were Jia Hao trying to prove?

- A: Air can be compressed.
- B: Air has no definite shape.
- C: Air has no definite volume.

- (1) A and B only
- (2) A and C only
- (3) B and C only
- (4) A, B and C

( )

17. A 100-ml measuring cylinder was filled with 30 ml of water. Four pebbles of different sizes were dropped into the water one at a time. The new water level was recorded after each pebble was dropped. The table below shows the readings that were recorded.

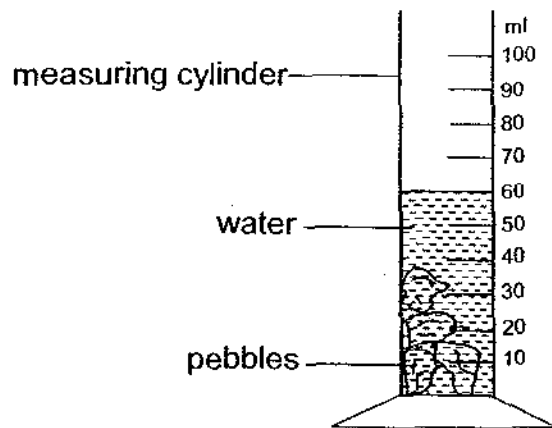

Pebble	New water level (ml)
J	35
K	45
L	52
M	60

Arrange the pebbles from the smallest to the biggest.

- (1) J, K, L, M  
 (2) L, J, K, M  
 (3) J, L, M, K  
 (4) K, M, L, J

( )

18. The diagrams below show what happens to a lever balance each time two objects are placed on it.

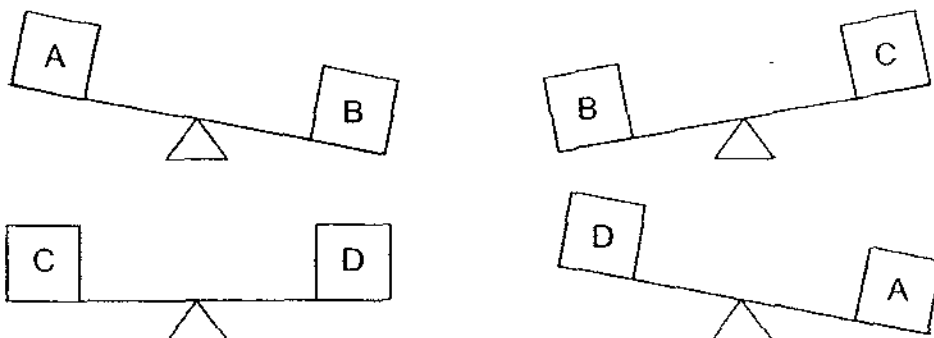

Which object has the greatest mass?

- (1) A  
 (2) B  
 (3) C  
 (4) D

( )

19. Andy, Bob, Clara and Desmond made a statement each about the three objects shown below.



500 g of flour



500 g of sand



500 g of marbles

- Andy: The three objects have the same mass.  
Bob: The three objects have the same volume.  
Clara: The three objects have definite masses.  
Desmond: The three objects have definite volumes.

Which of their statements is/are correct?

- (1) Andy only  
(2) Bob and Clara only  
(3) Andy and Desmond only  
(4) Andy, Clara and Desmond only

( )

20. Scuba divers carry tanks containing compressed air when they dive as shown below.



tank containing compressed air

Why is the air in the tank compressed?

- (X) To make the tank lighter  
(X) To reduce the mass of the air  
(X) To change the shape of the air  
(4) To decrease the volume of the air

( )

21. The apparatus below is half-filled with water.

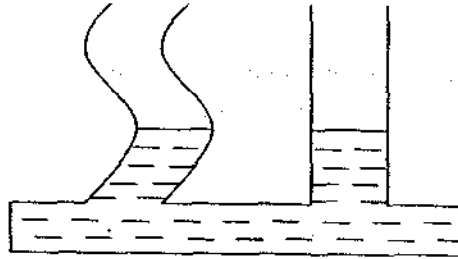

Which of the following correctly shows the water level when the apparatus is tilted?

(1)

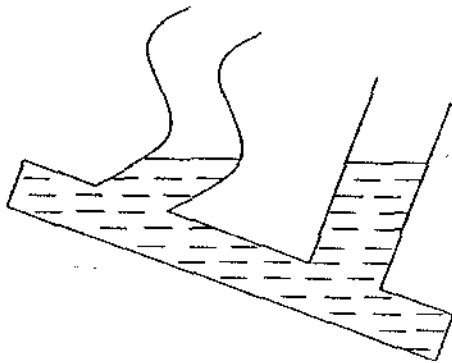

(2)

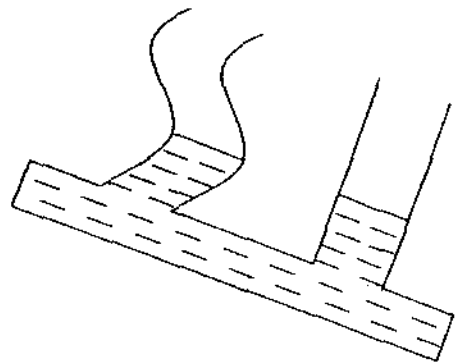

(3)

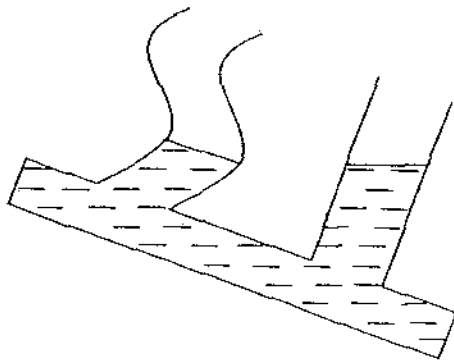

(4)

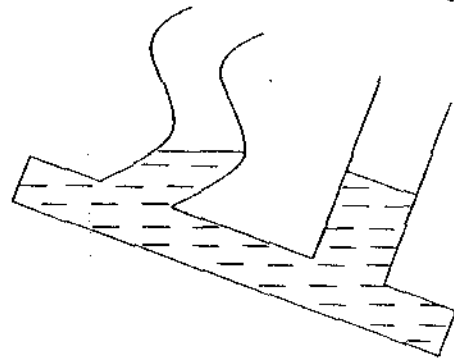

( )

22. Study the classification chart below.

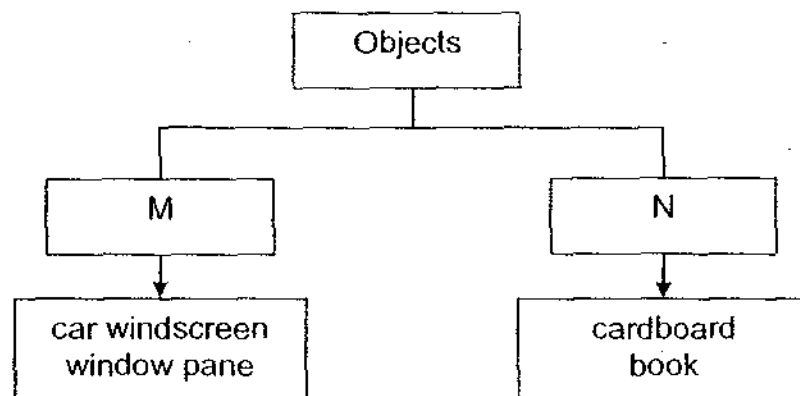

Which object can you put in Group M?

- (1) tissue paper
- (2) frosted glass
- (3) wooden block
- (4) spectacle lens

( )

23. Look at the diagram below.

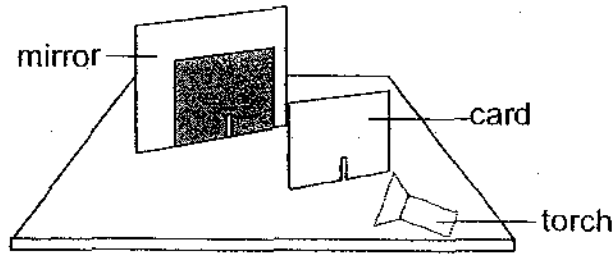

When the torch is switched on, light from the torch goes through the slit and is reflected by the mirror. Which of the following correctly shows the direction of the reflected ray of light?

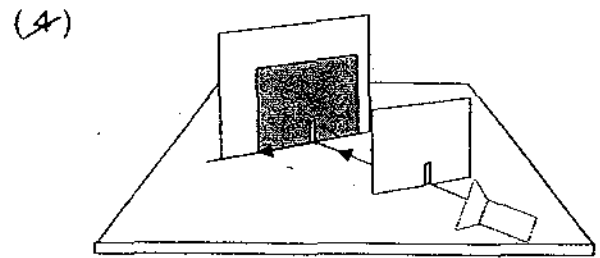
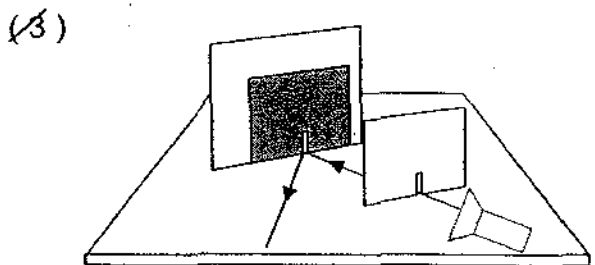
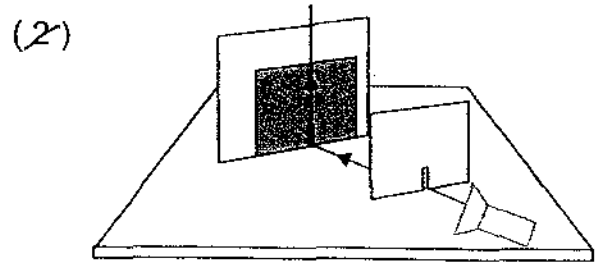
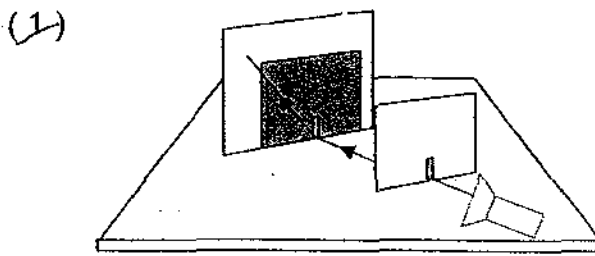

( )

24. A shadow is formed when light shines on a pole. Which of the following diagrams shows correctly what the shadow looks like?

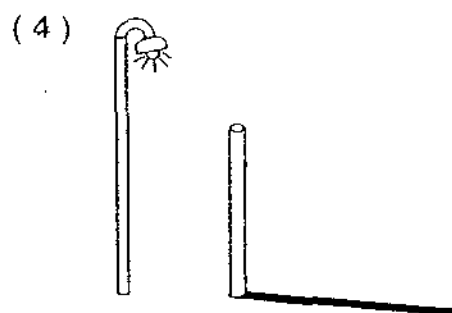
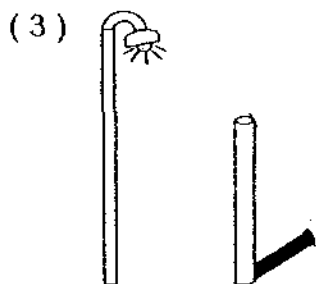
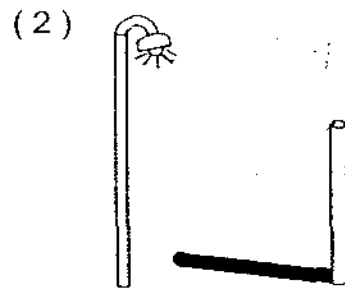
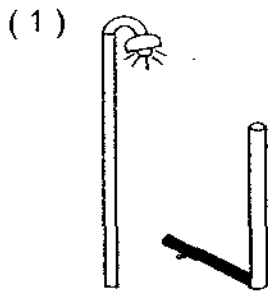

( )

25. In the following experiment, only the torch and the screen were in fixed positions.

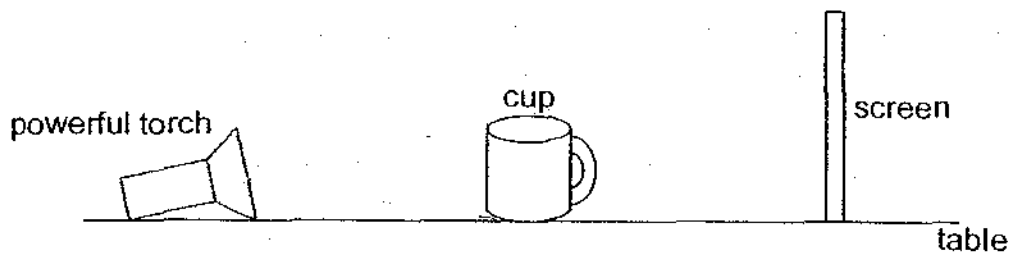

Which of the following shadows could not be projected on the screen?

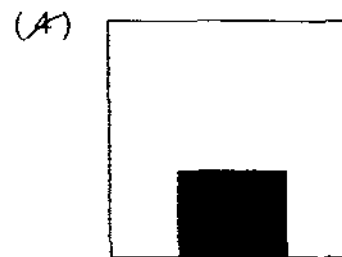
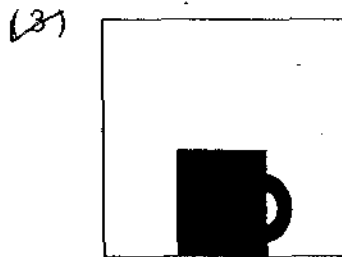
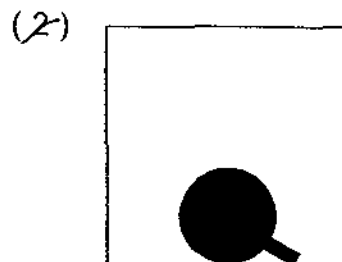
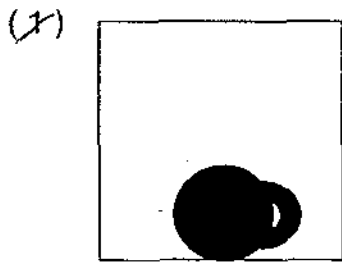

( )

For Questions 26 to 30, please refer to Booklet K.

End of Section A

**Pei Chun Public School**  
**Semestral Assessment 1 – 2009**  
**Science**  
**Primary 4**

Name: \_\_\_\_\_ (     )

Class: Pri. 4 (     )

Date: 15 May 2009

Time: 1 h 30 min

Science Teacher: \_\_\_\_\_

Parent's Signature: \_\_\_\_\_

Section A	60
Section B	30
Booklet K (excludes MCQs)	10
Total	100

**Section B (30 marks)**

For questions 31 to 40, write your answers in the spaces provided.

31. The diagram below shows a light bulb.

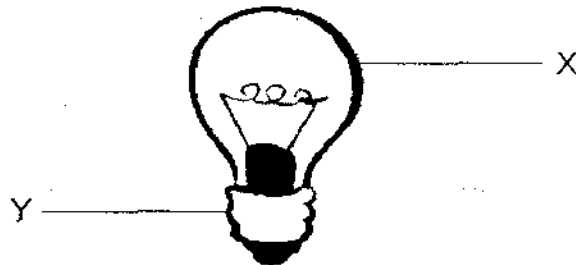

(a) What materials are parts X and Y made of? ( 1 m )

(i) X: \_\_\_\_\_

(ii) Y: \_\_\_\_\_

(b) Why is X made of this material? ( 1 m )

\_\_\_\_\_

\_\_\_\_\_

32. Study the flowchart below carefully.

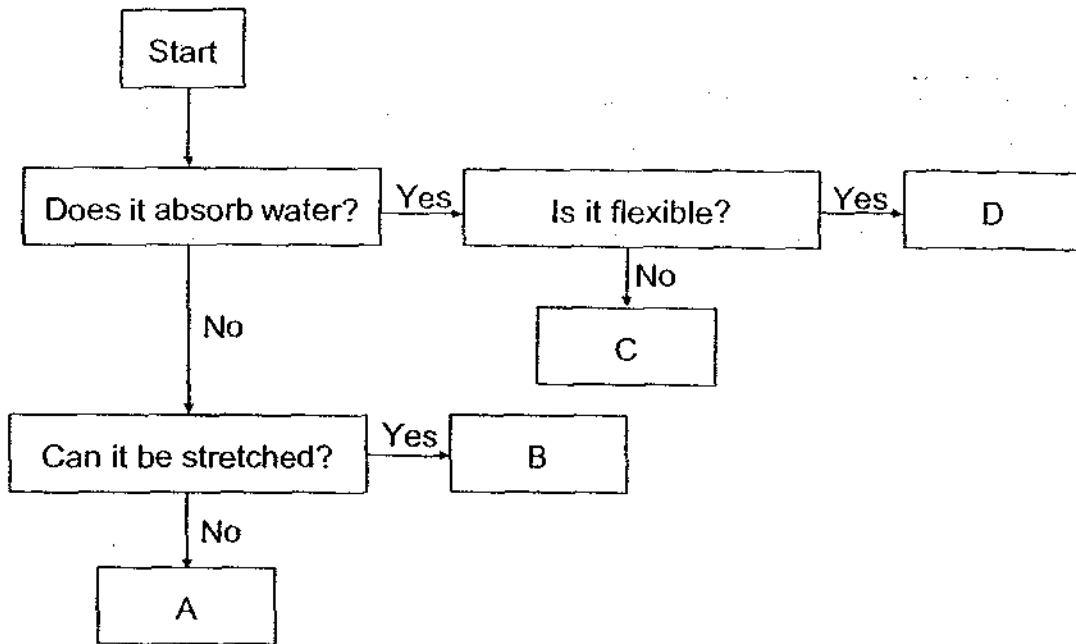

Match the following objects with the letters A, B, C and D. Each object can only be used once.

(2 m)

rubber band      wooden block      plastic cup      canvas shoe

Box	Object
A	
B	
C	
D	

Handwritten mark

33. Mary has two containers of the same size. She fills up container A with marbles and container B with water as shown below.

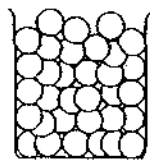

container A

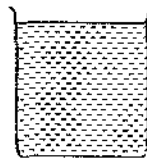

container B

- (a) What will happen when Mary pours all the water from container B into container A? (1 m)

---



---

- (b) What will happen when Mary pours all the marbles from container A into container B? (1 m)

---



---

- (c) What property of matter can Mary observe from these experiments? (1 m)

---

34. An inverted plastic cup with some dry tissue paper attached is slowly pushed into a basin of water.

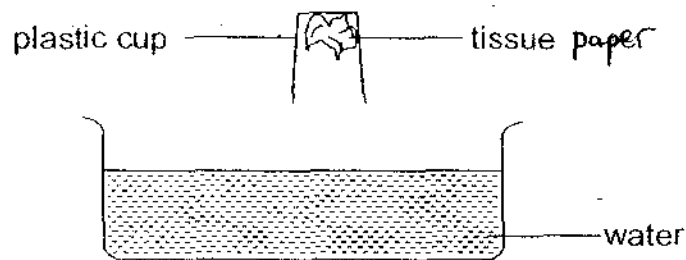

- (a) What will happen to the tissue paper? (1 m)

---

- (b) Explain your answer in (a). (2 m)

---



---

- (c) What property of air is shown in this experiment? (1 m)

35. In the diagram below, A, B and C represent the three states of matter.

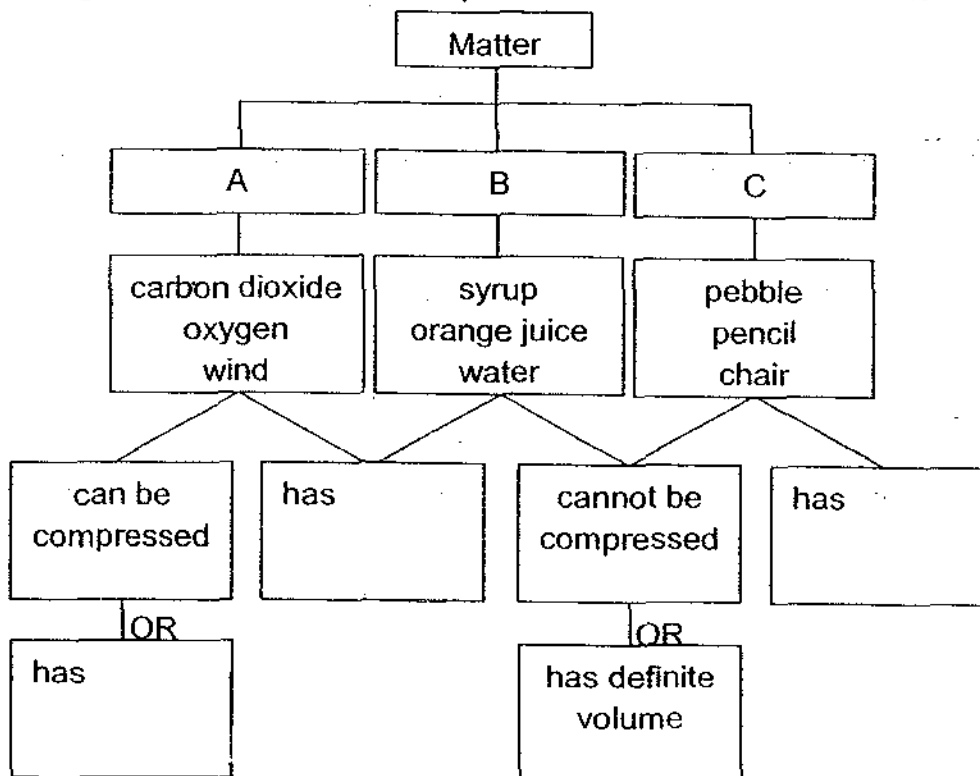

(a) Fill in each box with the correct property that describes the matching state(s) of matter. (1½ m)

(b) What state of matter is represented by B? (½ m)

36. Look at the diagram below.

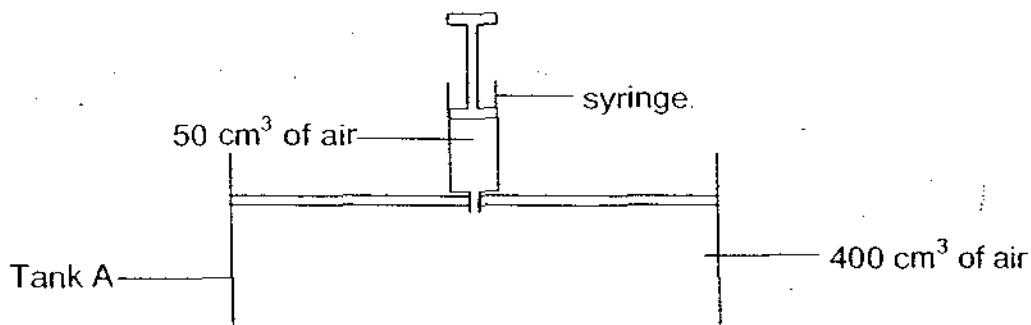

(a) What will the volume of air in Tank A be when the plunger of the syringe is pushed in completely? (1 m)

(b) Explain your answer in (a). (1 m)

(c) What does this experiment tell you about air? (1 m)

205

37. The diagram below shows the digestive system of the human body.

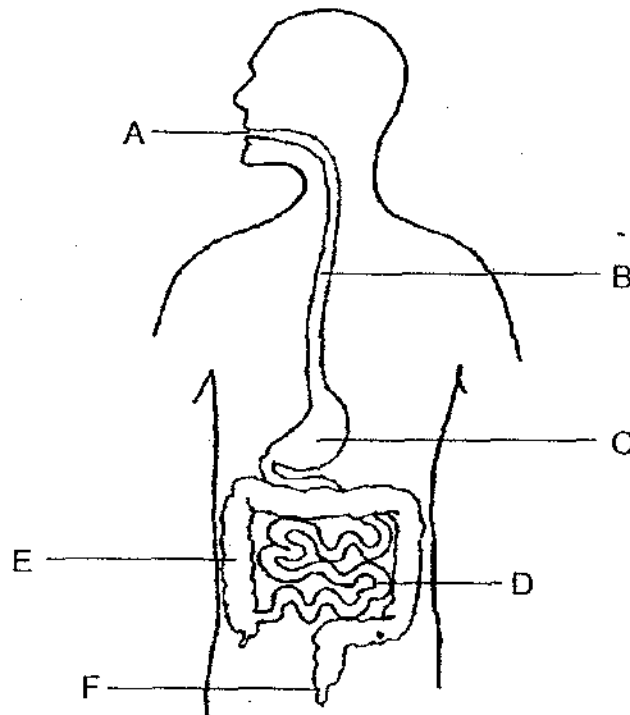

Write the correct letters in the boxes below.

(2 m)

	Function	Part of the digestive system
(a)	Absorbs water from undigested food	
(b)	Digestion of food is completed here	
(c)	Digestion of food starts here	
(d)	Undigested food is stored here temporarily	

38. The diagram below shows an ostrich.



(a) Elbie says an ostrich is not a bird because it cannot fly.  
Is he correct? Explain your answer.

(2 m)

---

---

(b) Place the following birds in the boxes below.

(2 m)

seagull	duck	emu	hummingbird
---------	------	-----	-------------

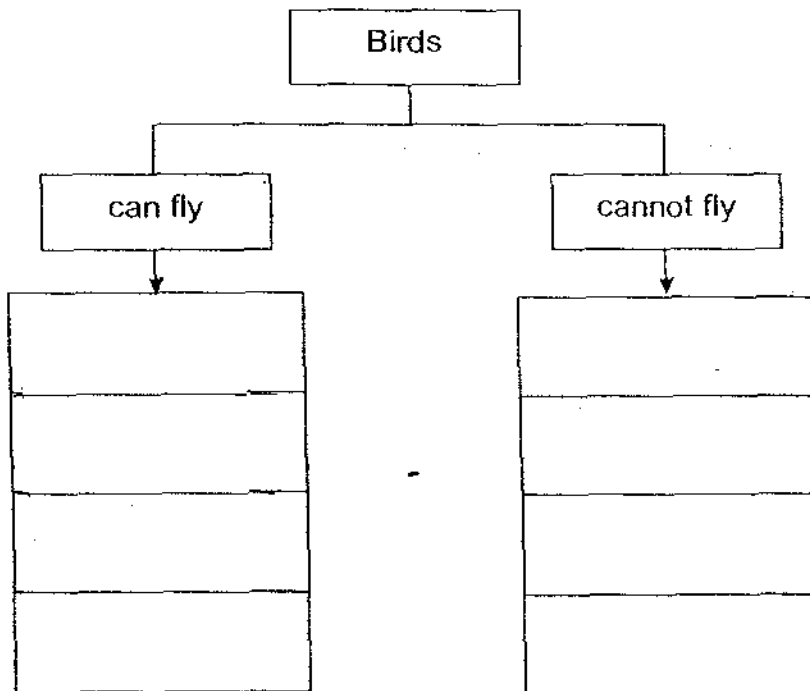

39. Look at the set-ups below. Two identical magnets, Y and Z, were suspended using two identical springs. Object M was placed below each magnet.

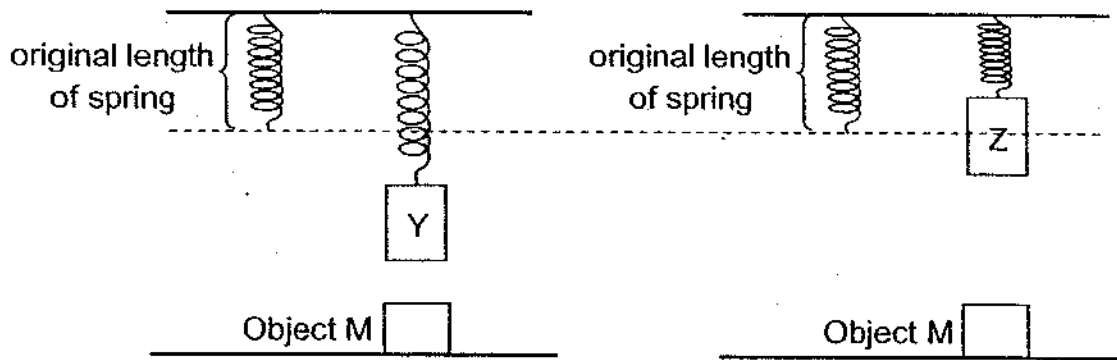

- (a) What could object M be? (1 m)

---

- (b) Explain why the spring attached to magnet Z was shorter than the spring attached to magnet Y. (3 m)

---

---

---

---

40. Susan conducted an experiment.

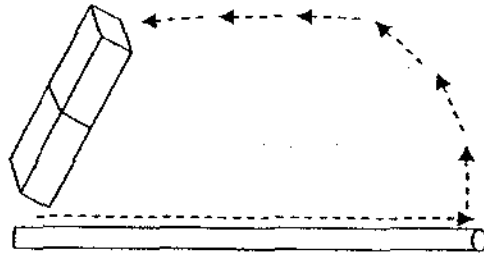

- Step 1: She stroked an iron rod with a strong magnet several times.  
Step 2: She then placed the iron rod in a dish of paper clips.  
Step 3: She recorded the number of paper clips the iron rod attracted.  
Step 4: She repeated Steps 1 to 3 with three other identical iron rods.  
Step 5: She recorded her findings in the table below.

Iron rod	Number of strokes	Number of paper clips attracted
S	10	2
T	20	5
U	30	7
V	40	9

- (a) What was the relationship between the number of strokes given to the iron rods and the number of paper clips attracted by the iron rods? (2 m)

---

---

- (b) Was Susan's experiment a fair test? Why? (1 m)

---

---

- (c) Could Susan carry out the experiment using aluminium rods of the same size as the iron rods? Why? (1 m)

---

---

For Questions 41 to 44, please refer to Booklet K.

End of Section B

Set by : Mdm Melissa Tan  
Vetted by: P4 Science Committee teachers

409



37)a)E      b)D      c)A      d)F

38)a)No, he is wrong because an ostrich cannot fly, the characteristics of a bird is having feather. An ostrich has feathers, determining that it is a bird.

<u>b)can fly</u>	<u>cannot fly</u>
humming bird	emu
seagull	
duck	

39)a)A magnet.

b)Unlike poles of Y and M are facing each other. They attract so the spring attached to Y is stretched .

Like poles of Z and M are facing each other. They repel so the spring attached to Z is compressed.

40)a)As the number of strokes given to the iron rods increases, the number of paperclips attracted by the iron rods increases.

b)Yes, because nothing was different besides the number of strokes.

c)No, she cannot because aluminium is non-magnetic and it cannot be magnetized.