



CATHOLIC HIGH SCHOOL
PRIMARY 4
SEMESTRAL ASSESSMENT 2, 2009

SCIENCE

Name: _____

Class : Primary 4 _____

Date : 29 Oct 2009

BOOKLET A

30 Questions
60 Marks

Total Time for Booklets A & B : 1 hour 30 minutes

Instructions to Candidates

Do not open this booklet until you are told to do so.
Follow all instructions carefully.
Answer all questions.

4047

147

Section A: Multiple Choice Questions (60 marks)

For each question from 1 to 30, four options are given. One of them is the most suitable answer. Make your choice (1, 2, 3 or 4) on the Optical Answer Sheet.

1. The picture shows of a koala.



Which one of the following statements tells you that the koala is a mammal?

- (1) It has hair covering its body.
- (2) It has two arms and two legs.
- (3) Its sharp eyes can see in the dark.
- (4) Its sharp claws help it to climb trees.

2. Study the classification table below.

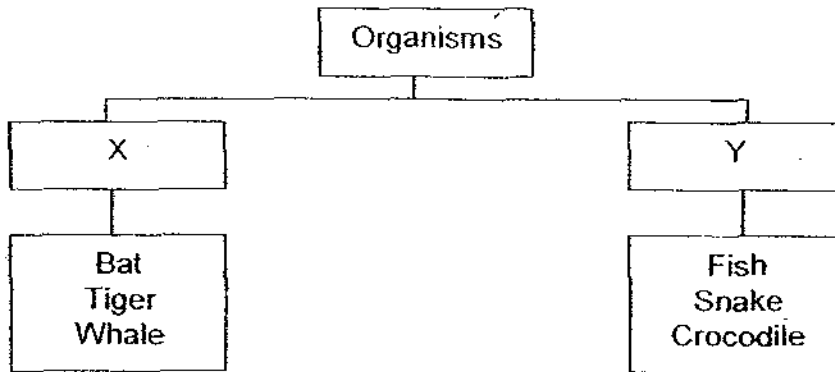

The organisms are classified according to _____.

- (1) the food they eat
- (2) the body coverings
- (3) the place they live in
- (4) the way they breathe

3. Specimen X was placed on the table with a brief description on it. The description reads:

- A It has a stalk.
- B It has no chlorophyll.
- C It cannot move from place to place.
- D It has no flowers.

Based on the description above, which one of the following would most likely be Specimen X?

- ~~(1)~~ Fern
- ~~(2)~~ Moss
- ~~(3)~~ Cactus
- ~~(4)~~ Toadstool

4. How is the part labelled X useful to the plant during photosynthesis?

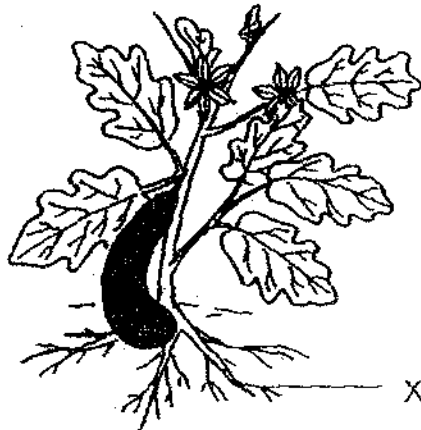

- ~~(1)~~ It contains chlorophyll.
- ~~(2)~~ It produces carbon dioxide.
- ~~(3)~~ It carries water up to the leaves.
- ~~(4)~~ It takes in water from the surroundings.

5. Kandy wants to investigate how the amount of light affects the growth of a type of plant. The diagram below shows each of her set-ups in a clear glass tank.

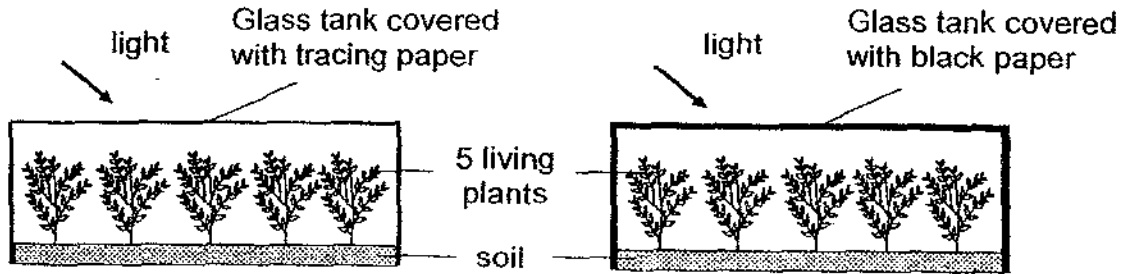

Which one of the following could she use as a control for her experiment?

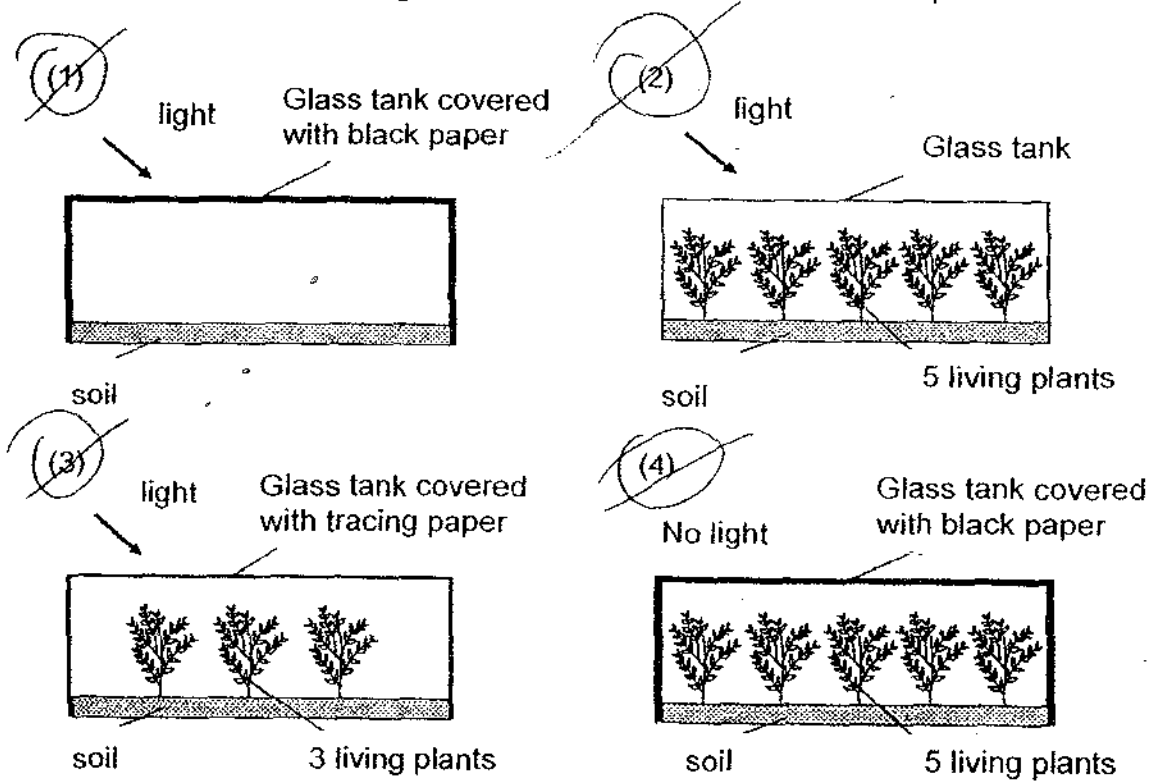

6. In an investigation, only the top of the leaves of a plant are covered with black paper.

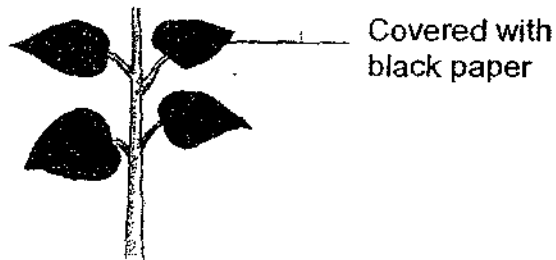

How will this affect the plant?

- A The plant cannot give out excess water.
- B The plant will not be able to get enough air.
- C The plant will not be able to make much food.
- D The plant cannot absorb much energy from the Sun.

- ~~(1)~~ A only
- ~~(2)~~ A and B only
- ~~(3)~~ B and C only
- (4) C and D only

7. In what way is the plant transport system and human transport system similar?

- A Both systems transport food and water.
- B Both systems have tubes to transport materials.
- C Both systems transport oxygen and carbon dioxide.
- D Both systems need an organ to pump the materials in the tubes to different parts.

- ~~(1)~~ A and B only
- ~~(2)~~ B and C only
- ~~(3)~~ A, B and C only
- (4) A, B and D only

8. I am an organ in the human body. I produce digestive juices to further break down partly digested food that I received. The environment inside me is acidic. I also churn, crush and mash food till they become a thick liquid. Then, I send the food to another part for further digestion.

Which organ am I?

- ~~(1)~~ Gullet
- ~~(2)~~ Stomach
- ~~(3)~~ Small intestine
- ~~(4)~~ Large intestine

9. Our hearts and lungs are protected by the _____ and our brain is protected by the _____.

- ~~(1)~~ ribcage...backbone
- ~~(2)~~ ribcage...skull
- ~~(3)~~ backbone...skull
- ~~(4)~~ chest...head

10. Most digested food are absorbed in A and carried by B to all parts of the body.
Which one correctly represents A and B?

A	B
(1) Large intestine	Gullet
(2) Small intestine	Blood
(3) Gullet	Small intestine
(4) Small intestine	Digestive juices

11. The organs below are supposed to be grouped according to the body system that they belong to.

Skeletal System	Digestive System
Skull	Stomach
Ribcage	Heart
Lungs	Intestines

Which of the above organs are wrongly placed ?

- (1) Skull and Heart
 (2) Lungs and Heart
 (3) Lungs and Intestines
 (4) Ribcage and Stomach

12. Study the life cycles of the two animals below.

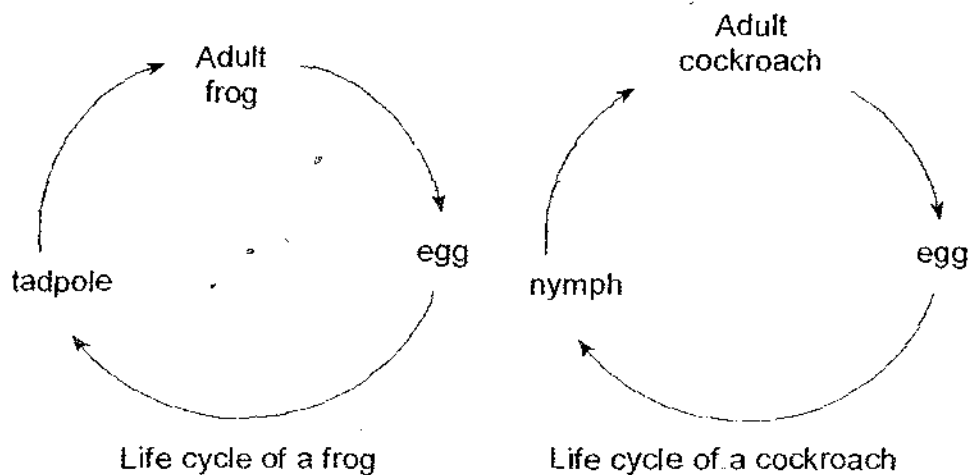

Which of the following statements are true about the two life cycles?

- A Both have 3 stages of life cycle.
 B The eggs are laid in water.
 C Both animals hatch from eggs.
 D The young of both animals look like the adult.

- (1) A and C only
 (2) A, B and C only
 (3) B, C and D only
 (4) A, B, C and D

13. Vivian placed a seed in a container of soil and observed the seed for a few days. She recorded her observations in the table below.

Day	Observations
1	Seed swells.
2	Roots appear.
3	Two leaves appear between the seed leaves. The roots grow longer.
4	The shoot grows longer. The first two leaves spread open and become greener. The roots grow longer. The seed leaves drop off.
5 to 14	The shoot grows even longer. More leaves appear. The roots become even longer.
15	The first flower bud appears.
16	The first flower blooms.

Which one of the following statements about Vivian's observations is correct?

- (1) The plant produced a fruit on day 15.
- (2) The plant made its own food on day 2.
- (3) The plant will be able to bear fruits after Day 16.
- (4) The young plant depended on the seed leaves for food for 14 days.

14. Study the classification table below.

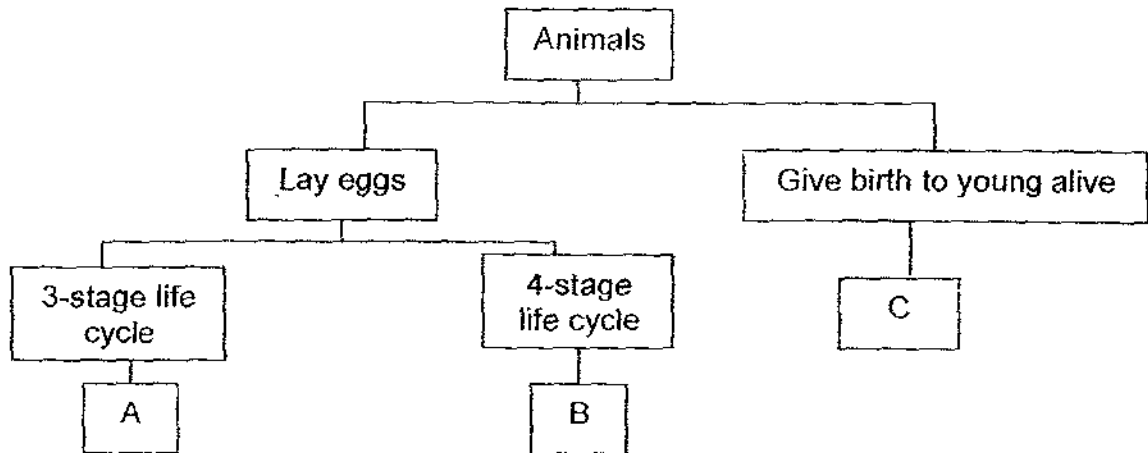

What could A, B and C represent?

	A	B	C
(1)	Chicken	Mosquito	Tiger
(2)	Mosquito	Cockroach	Rabbit
(3)	Grasshopper	Chicken	Guppy
(4)	Dragonfly	Cockroach	Grasshopper

15. What do solids, liquids and gases have in common?

- (1) All of them occupy space and have mass.
- (2) All of them occupy space but have no mass.
- (3) All of them have definite shape and definite volume.
- (4) All of them have definite volume but no definite shape.

16. A measuring cylinder contains some water. The following diagram shows what happens to the level of water when the different objects are dropped into the same cylinder of water.

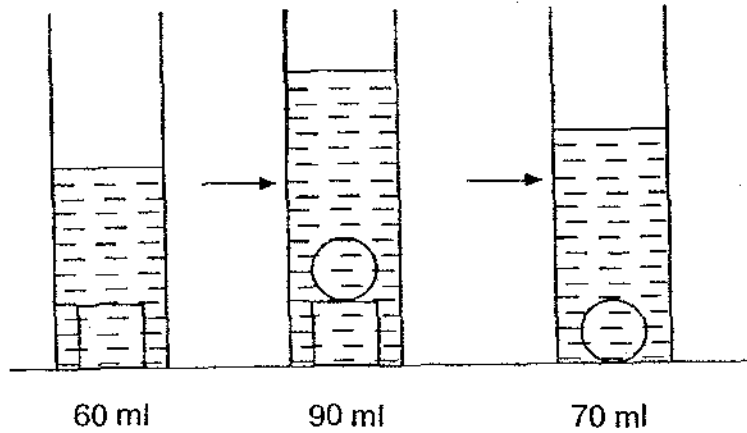

Observe the change in level of water in the diagram above. How much water was in the measuring cylinder before the objects were dropped into it?

- (1) 20 ml
- (2) 30 ml
- (3) 40 ml
- (4) 50 ml

17. The table below shows the properties of W, X, Y and Z.

	Matter	Definite shape	Definite volume	Can be compressed
W	X	X	X	X
X	✓	✓	✓	X
Y	✓	X	✓	X
Z	✓	X	X	✓

Study the table above and identify W, X, Y and Z.

	W	X	Y	Z
(1)	Wind	Coin	Water	Oxygen
(2)	Wind	Coin	Oxygen	Water
(3)	Heat	Water	Coin	Oxygen
(4)	Heat	Coin	Water	Oxygen



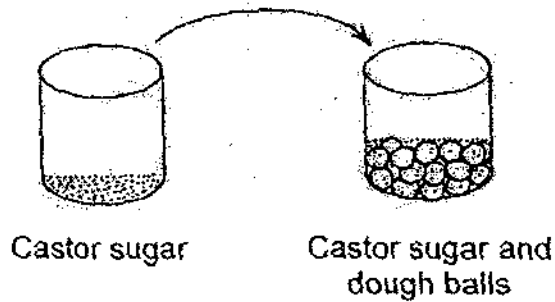

18. Aminah poured 30 cm^3 of castor sugar into a beaker that contained 70 cm^3 of dough balls. She then shook the beaker gently. She found that the total volume of the castor sugar and dough balls was less than 100 cm^3 .

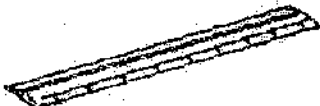

- What conclusion can Aminah draw from this experiment?
- ~~(1)~~ The dough balls were compressed.
 - ~~(2)~~ Some of the castor sugar overflowed.
 - ~~(3)~~ Air filled up the spaces among the castor sugar.
 - ~~(4)~~ Some of the castor sugar filled the spaces between the dough balls.

19. Daniel was investigating the properties of a metal ruler, a plastic spoon, a rubber band and a porcelain mug. He found that one of these objects was able to float, was flexible and did not break easily.

Which one of the objects has the properties described above?

- | | | | |
|----------------|---|----------------|---|
| (1) |  | (2) |  |
| | metal ruler | | plastic spoon |
| (3) |  | (4) |  |
| | rubber band | | porcelain mug |

20. Amanda used an iron nail to scratch on four different pieces of tiles. What is she trying to find out?

- ~~(1)~~ She is trying to find out how strong the iron nail is.
- ~~(2)~~ She is trying to find out how flexible the iron nail is.
- ~~(3)~~ She is trying to find out which piece of tile is the hardest.
- ~~(4)~~ She is trying to find out which piece of tile is the most flexible.

21. Josephine places three ring magnets through a wooden support. The magnets push each other as shown in the diagram below.

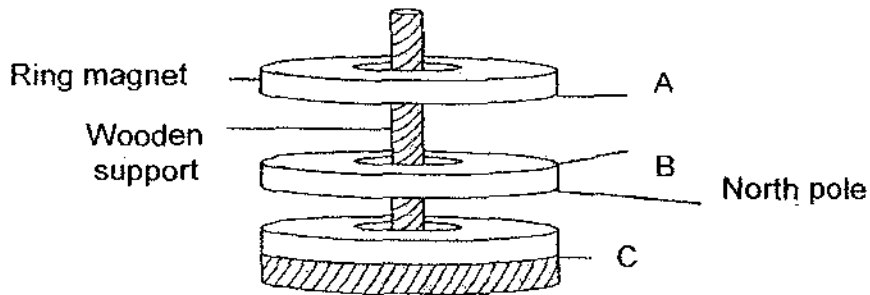

Which one of the following represents the poles of the magnets labelled A, B and C?

	A	B	C
(1)	North pole	North Pole	South pole
(2)	North pole	South pole	North pole
(3)	South pole	South pole	South pole
(4)	South pole	North pole	North pole

22. The graph and notes below are taken from Damien's Science notebook.

Materials used for the experiment: Horse shoe magnet, paper clips made of iron, ruler

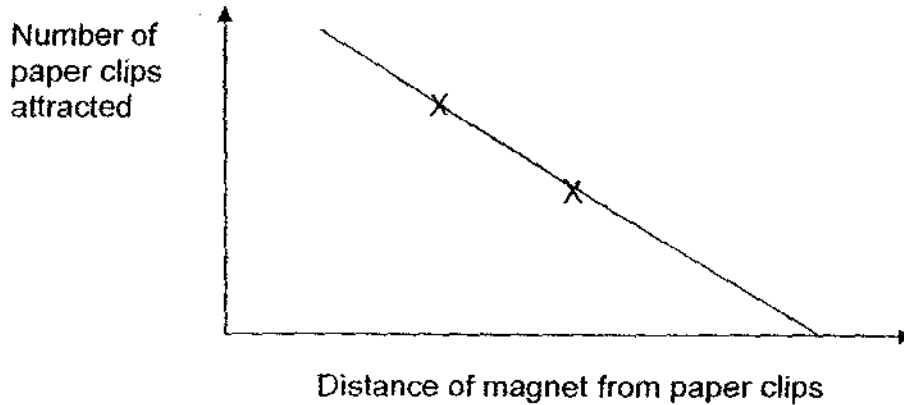

What are the possible conclusions that Damien can draw from the experiment?

- A Iron is a magnetic material.
- B The strongest magnet is the horse shoe magnet.
- C If the magnet is too far away, it will be too weak to attract objects.
- D The further the magnet is to an object, the stronger the magnetism.

- ~~(1)~~ A only
- ~~(2)~~ A and C only
- ~~(3)~~ A, B and C only
- ~~(4)~~ A, B, C and D

23. Which one of the examples below is a light source?

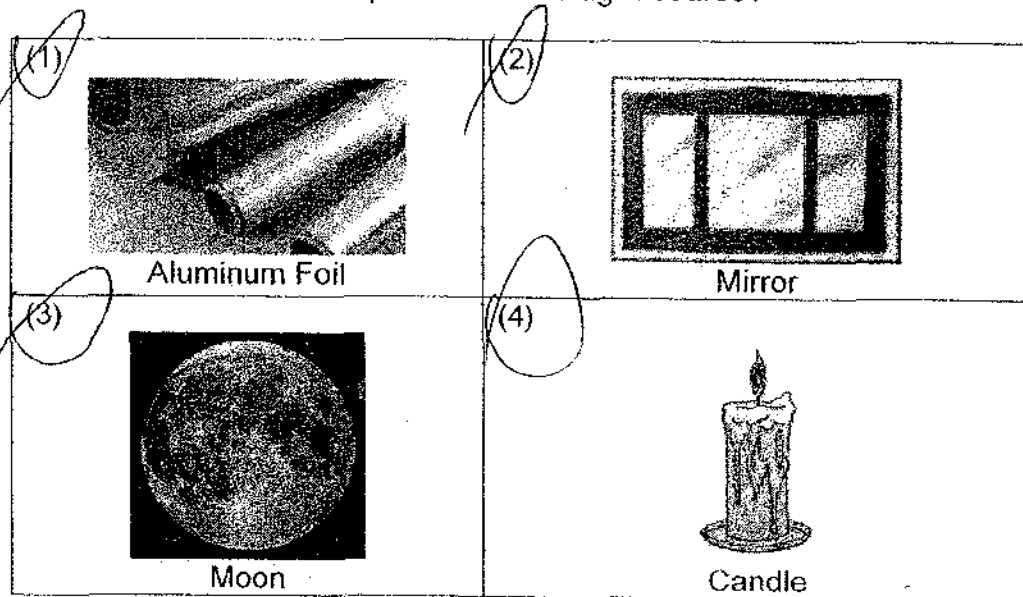

24. Four similar torches with equal brightness were shone at four different discs. Their shadows could be seen on the screens. What could these four discs be?

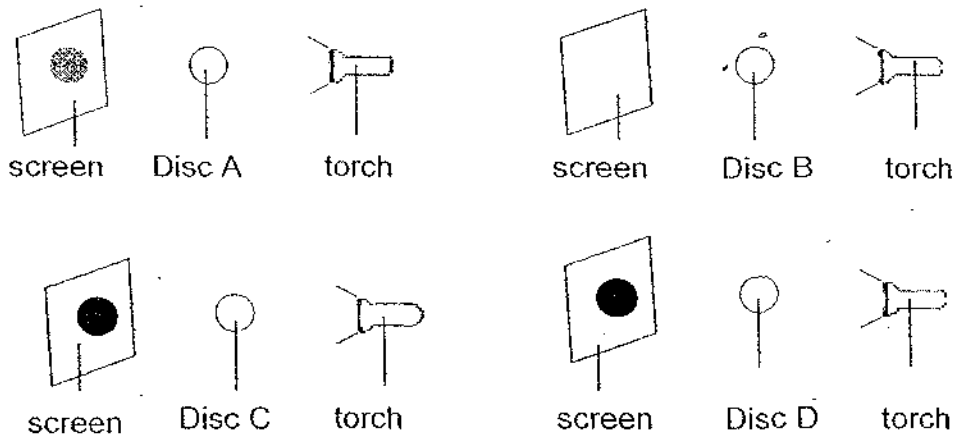

	Disc A	Disc B	Disc C	Disc D
(1)	Tracing paper	Mirror	Book	Clear glass
(2)	Book	Clear glass	Tracing paper	Mirror
(3)	Mirror	Tracing paper	Clear glass	Book
(4)	Tracing paper	Clear glass	Book	Mirror

25. In the experiment shown below, a periscope is placed in front of a signboard.

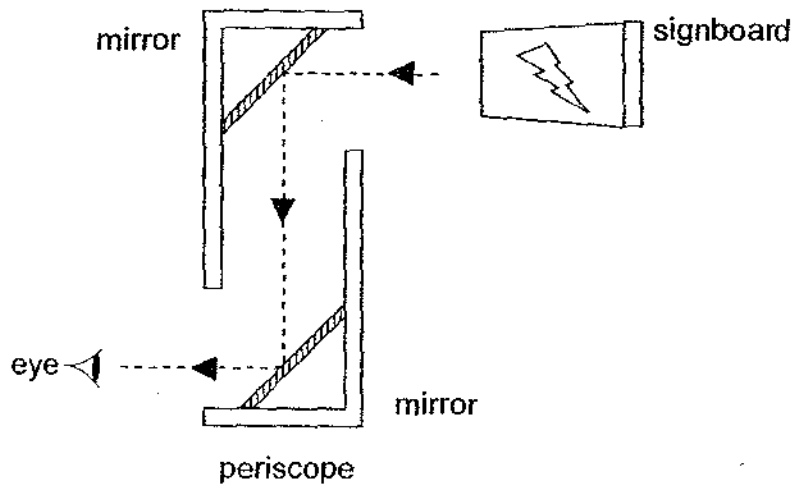

Which one of the following shows the correct image as seen by the eye?

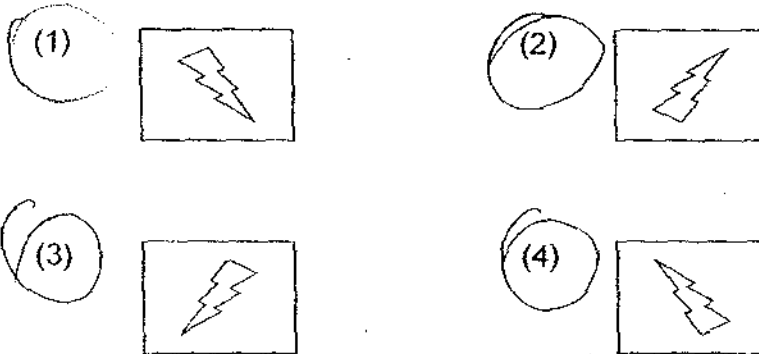

26. Shasha wants to carry out an experiment to find out if the hot water in a glass with a thicker wall, would take a longer time to cool.

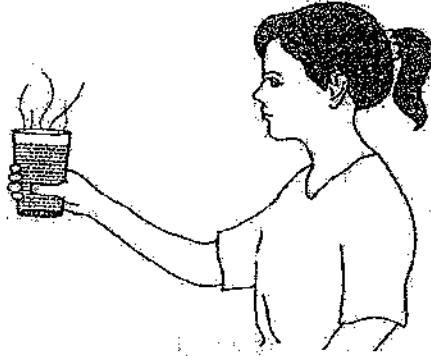

Shasha should keep all the variables in her experiment the same except for one variable. Which one of the following variables should she change?

- (1) The size of the glasses.
- (2) The amount of water in the glasses.
- (3) The thickness of the walls of the glasses.
- (4) The starting temperature of the water in the glasses.

27. Ali carried out an experiment as shown below.

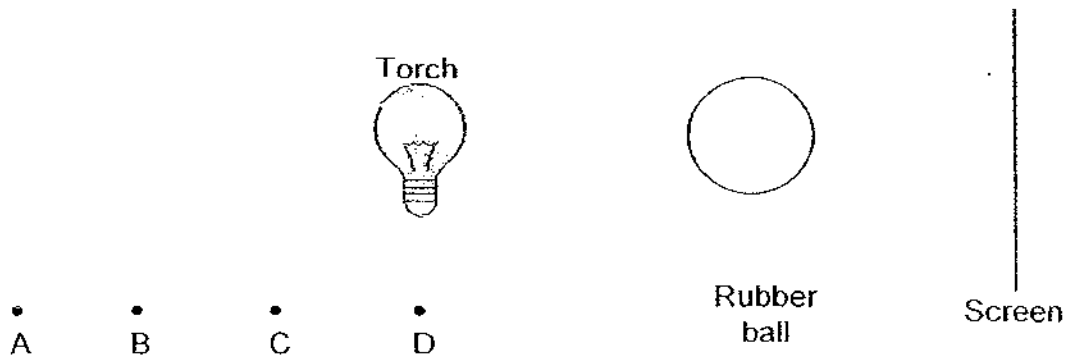

Ali placed the torch at position D and drew the size of the shadow the rubber ball formed on the screen. He did the same for positions A, B and C. He recorded the size of the shadows in the table below.

Drawing of Shadow	Position of Torch			
	A	B	C	D

Which one of the following could be his final answer?

	Position of Torch			
	A	B	C	D
(1)				
(2)				
(3)				
(4)				

28. Anne attached a wooden rod to a steel iron. She wrapped a piece of paper tightly round both materials in the centre of the rod. After that, she placed the rod over a flame as shown in the diagram below. What will she observe?

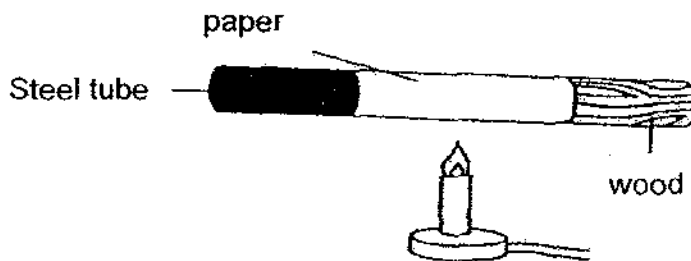

- (1) The steel tube was burnt.
- (2) Only the paper on the steel rod is scorched.
- (3) Only the paper on the wooden rod is scorched.
- (4) The paper on the wooden side and steel side is scorched.

29. A piece of aluminium foil and thick towel were placed on a table. The palm of one hand was on the aluminium foil and the other on the towel. Why does the foil feel colder than the towel, although both are at room temperature?

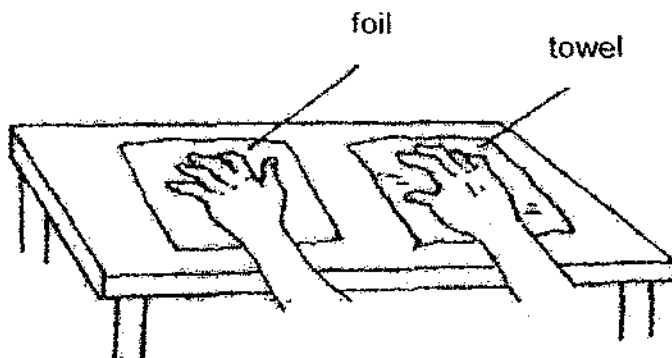

- (1) The foil radiates heat from our palm while the towel does not.
- (2) The towel receives heat and reflects it back to the palm and hence, the palm feels warm.
- (3) The foil is a better conductor of heat than the towel, and hence, conducts the heat faster from our palm.
- (4) The towel conducts heat faster and when we place our hand on it, the heat from our palm is passed on quickly to the foil.

30. P, Q, R and S are blobs of wax on a piece of metal shaped in the form of a rectangle of length 26 cm and breadth 10 cm, as shown in the diagram below.

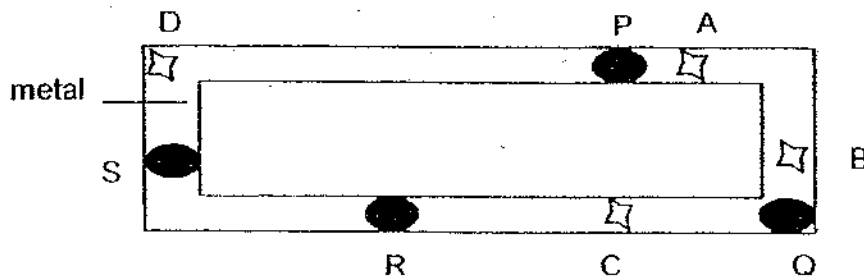

When a certain part of the metal is heated, the blobs of wax melted in the order of Q, R, P and S, at which point, A, B, C and D is the wire heated?

- (1) A
 (2) B
 (3) C
 (4) D

- END OF SECTION A -



**CATHOLIC HIGH SCHOOL
PRIMARY 4
SEMESTRAL ASSESSMENT 2, 2009**

SCIENCE

Name: _____ ()

Class : Primary 4 _____

Date : 29 Oct 2009

BOOKLET B

16 Questions
40 Marks

Total Time for Booklets A & B: 1 hour 30 minutes

Instructions to Candidates

Follow all instructions carefully.
Answer all questions.

Parent's Signature: _____

Date: _____

Score	
Section A	/
	60
Section B	/
	40
Total	/
	100

Section B: Open-Ended Questions (40 marks)

Read the following questions carefully and write your answers in the space provided. The maximum marks that can be awarded is shown at the end of each question or part-question.

31.



Toadstool



Tree fern

- (a) Give one difference between the two organisms shown above in terms of their nutrition. [1]

- (b) List one similarity between the two organisms. [1]

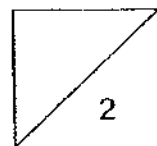

32. Mei Ling set up the experiment shown below. She wanted to find out how much water would be absorbed by the plant in five days.

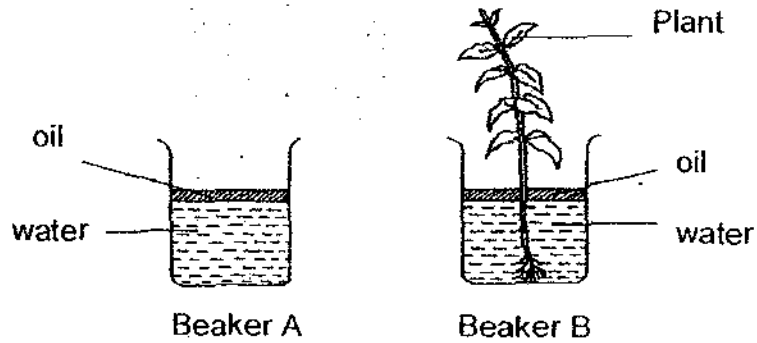

Beaker	Volume of water at the start of experiment	Volume of water at the end of experiment
A	300 ml	?
B	300 ml	160 ml

- (a) How much water will remain in Beaker A at the end of the experiment? [1]
- _____
- (b) What is the volume of water absorbed by the plant in five days? [1]
- _____
- (c) What is the purpose of setting up beaker A? [1]
- _____
- _____

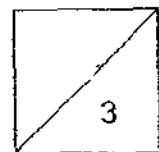

33. While food is in our mouth, it is partly digested. The partly-digested food is then swallowed and is passed down our gullet.

(a) What substance in our mouth helps to partly digest the food? [1]

(b) Why is food not further digested in our gullet? [1]

34. The diagrams below show the life cycles of two animals.

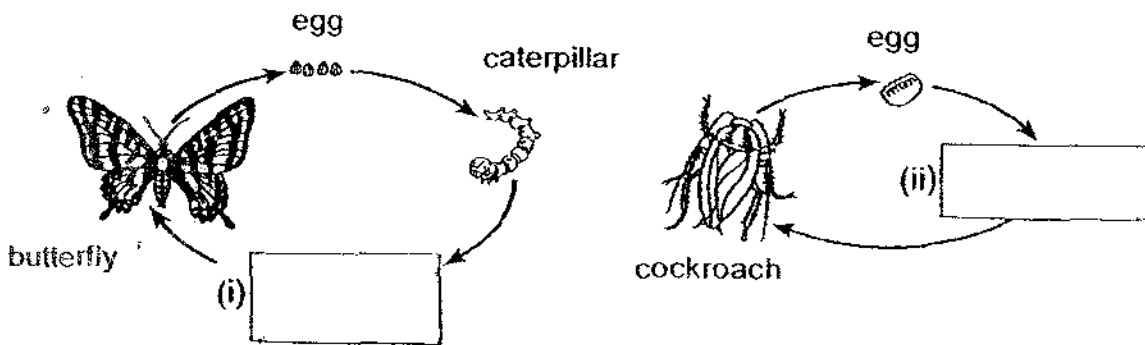

(a) Write the names of the stages in the boxes provided. [1]

(b) How is the life cycle of the two animals different? [1]

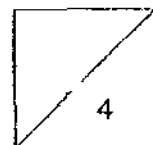

35. A bean seed was soaked in water for two days and then split open and a young plant was found inside it. Below is a diagram of the young plant.

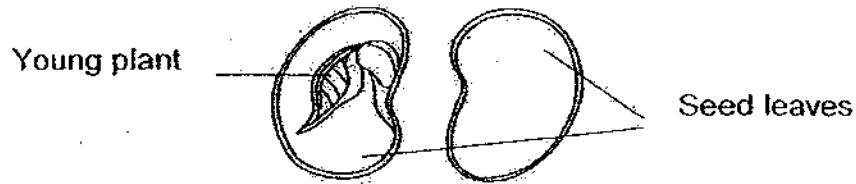

- (a) If the seed leaves are removed from the young plant, the plant will not continue to grow. Explain why. [2]

- (b) What conditions must be present for seeds to germinate? [1]

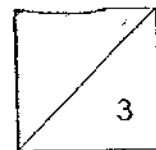

36. Study the set up below.

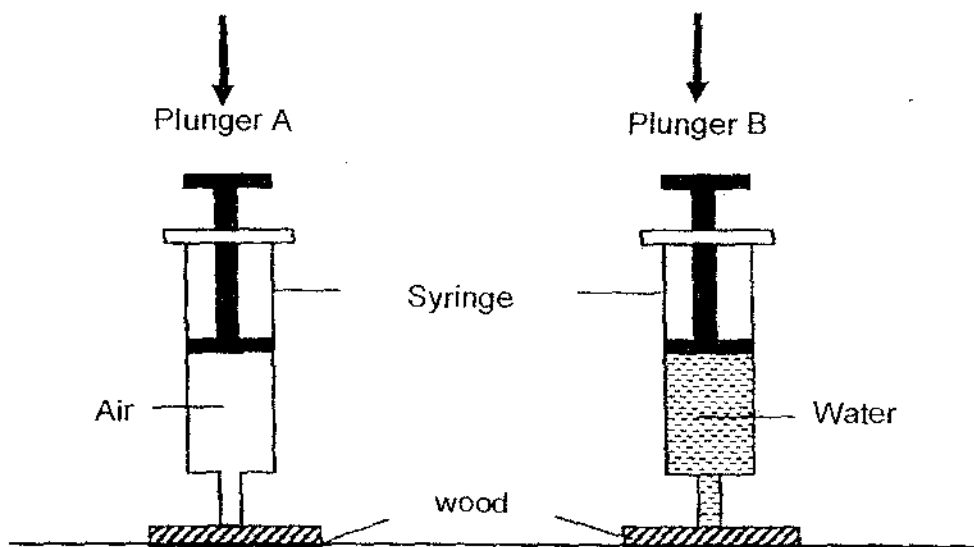

- (a) What will happen if the plungers of both syringes are pushed in at the same time? [2]

- (b) Explain your answer for part (a). [1]

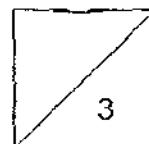

37. Study the diagram below.

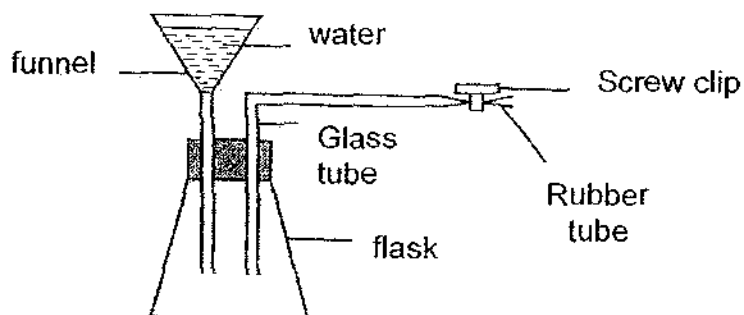

- (a) The screw clip is screwed tightly. When water is poured into the funnel, it does not flow into the conical flask. Explain this. [2]

- (b) What has to be done to allow the water to flow into the flask? [1]

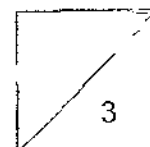

38. Angie makes a 'soap-holder'. She pushes a piece of steel rod into a bar of soap. The bar of soap is then fixed to a piece of metal Z that is attached to a plastic fixture just above the kitchen sink.

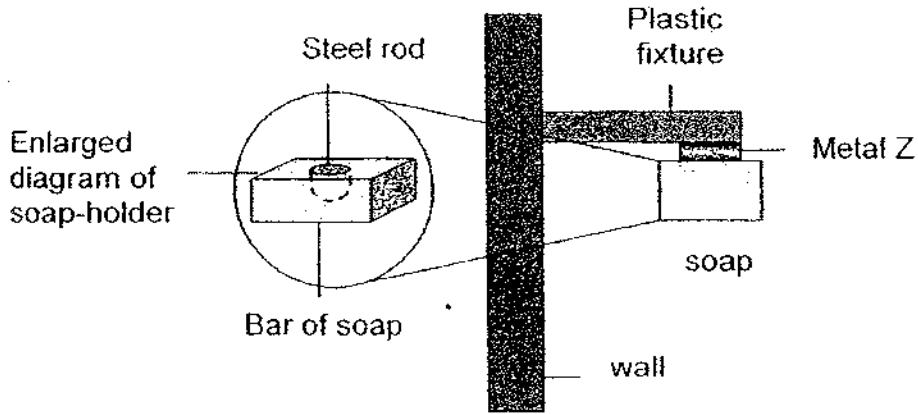

- (a) What property must Z have to ensure the bar of soap does not drop into the sink? [1]

- (b) Angie also holds the knives in her kitchen as shown in the diagram below.

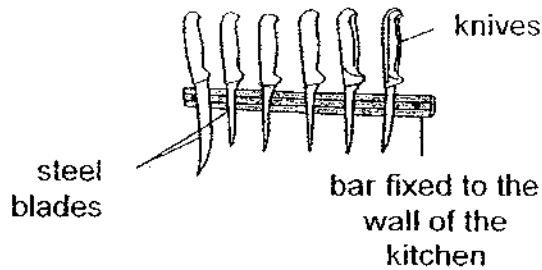

- Explain why the knives would not fall off the wall. [2]

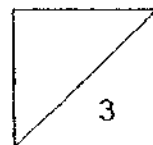

39. Amy shone a torch onto a wooden block from different positions and measured the length of the shadows formed. She recorded the values in the table below.

Position of torch	1	2	3	4	5	6	7
Length of shadow / cm	10	8	6	1	4	7	9

- (a) Present the above information in the graph below. [2]

Length of shadow (cm)

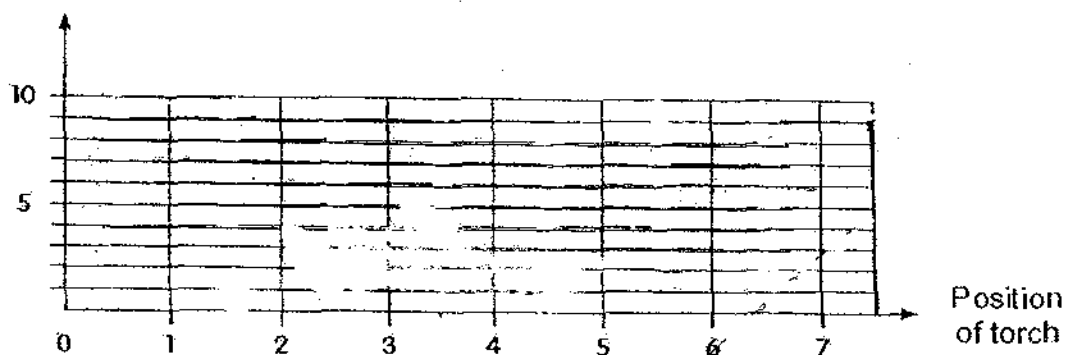

- (b) From your bar chart, what is the difference in length between the longest and shortest shadow? [1]

- (c) The diagram below shows the set up for Amy's experiment. The positions of the torch can be mapped onto path AC.

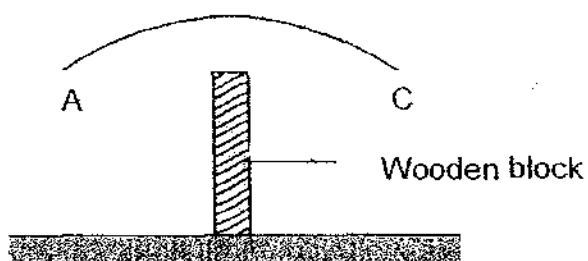

With a cross (X), mark on the path AC, a possible location of position 4. [1]

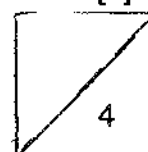

40. Gary performed an experiment using the set-up shown below.

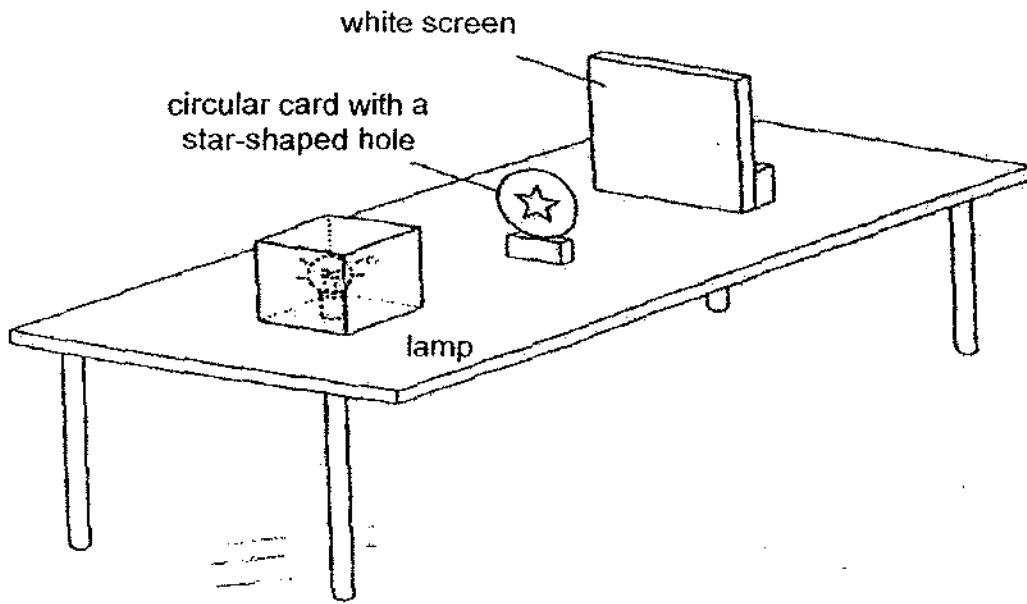

A shadow was formed on the white screen.

(a) How did the shadow form on the screen? [2]

(b) Shade on the diagram below to show the shadow that was formed on the white screen. [1]

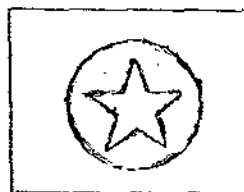

(c) Gary placed the circular card nearer to the white screen. Write down one change he would observe about the shadow. [1]

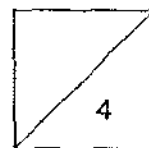

41. Study the diagram below.

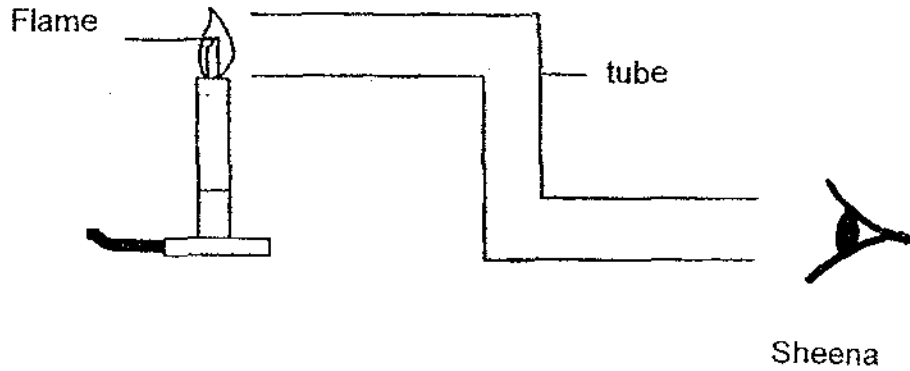

- (a) When Sheena looked through the tube shown above, she was unable to see the flame. Explain why this is so. [1]

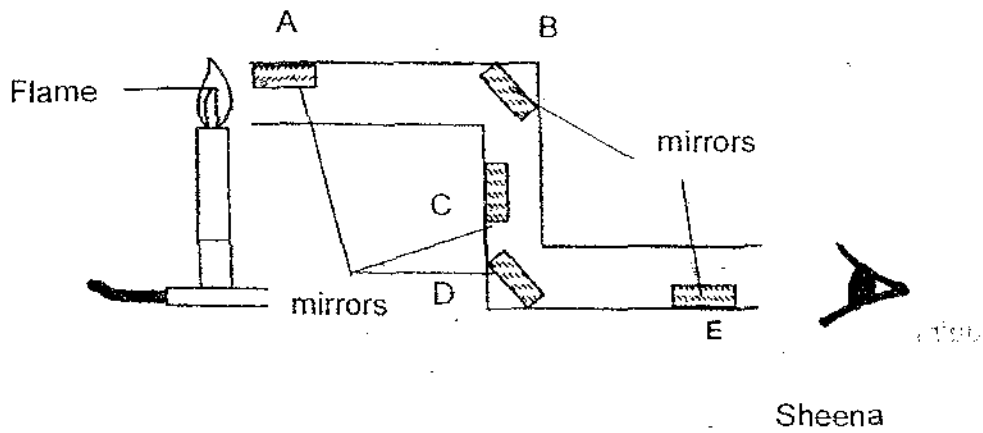

- (b) In order to see the candle, Sheena should place two mirrors at positions _____ and _____ [2]

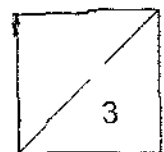

42. Jaime poured 100 ml of water into 4 similar beakers. The temperature of the water in all the beakers was 75°C. She wrapped each beaker with a different material. After 15 minutes, she measured the temperature of the water in each beaker and recorded her findings in the table below.

Beaker	Material	Temperature of water after 15 minutes
1	A	40°C
2	B	55°C
3	C	49°C
4	D	57°C

- (a) What was Jaime trying to find out in this experiment? [1]

- (b) Why was there a decrease in the temperature of water in each beaker? [1]

- (c) Jaime wanted to take some ice-cream from her freezer to her friend's house. From the above experiment, which material should the container be made of, so that the ice-cream would not melt when she reach her destination? [1]

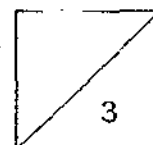

43. Jeremiah used a datalogger to measure the temperature of wax.

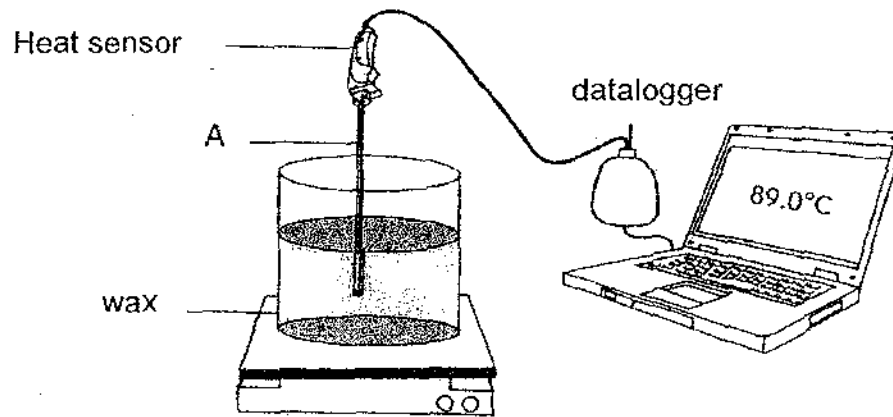

The melting point of wax is 79°C.

(a) What is the state of the wax in the container? [1]

(b) When the heat sensor is lifted from the wax, Jeremiah notices a thin solid layer around it. Explain how this solid layer came about. [2]

3

44. Three similar cans containing the same amount of X, Y and Z are left standing in the field on a sunny day for the same period of time. They are then moved to a room and the temperatures of the substances are taken every two minutes. The results are shown in the graph below.

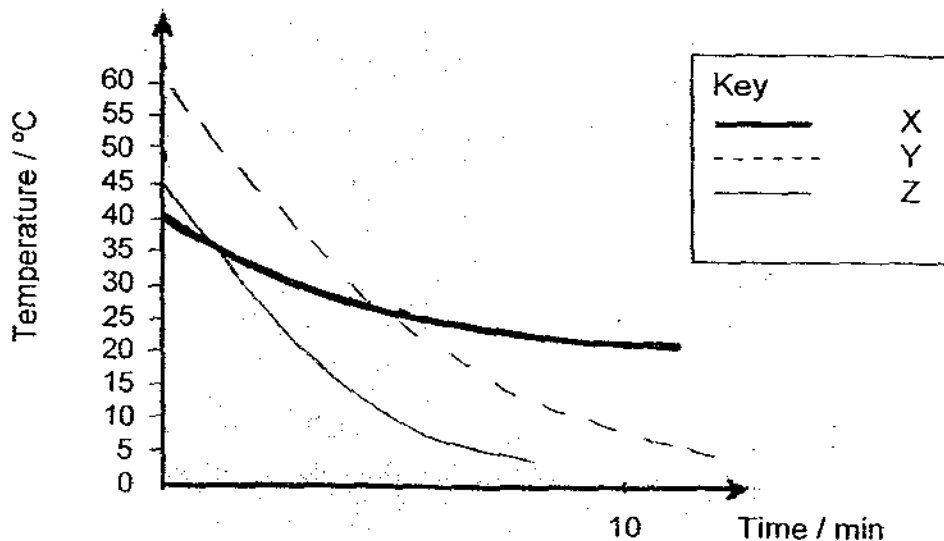

- (a) Based on the above graph, which one of the three substances is best for retaining heat? [1]

- (b) Give a reason for your answer in (a). [1]

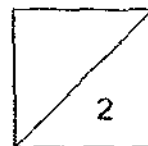

-END OF PAPER-

ANSWER SHEET

EXAM PAPER 2009

SCHOOL : CATHOLIC HIGH PRIMARY
SUBJECT : PRIMARY 4 SCIENCE

TERM : SA2

Q1	Q2	Q3	Q4	Q5	Q6	Q7	Q8	Q9	Q10	Q11	Q12	Q13	Q14	Q15	Q16	Q17
1	2	4	4	2	4	3	2	2	2	2	1	3	1	1	3	4

Q18	Q19	Q20	Q21	Q22	Q23	Q24	Q25	Q26	Q27	Q28	Q29	Q30
4	3	3	3	2	4	4	1	3	3	3	3	3

31)a) Toadstools do not make their own food, they absorb food from other organisms while tree ferns make their own food.

b) They both reproduce by spores.

32)a) 300ml b) 140ml

c) It acts as a control to show the difference in the volume of water which is due to the plants taking in water.

33)a) The substance is saliva.

b) The gullet does not have digestive juice to digest the food.

34)a) i) Pupa ii) Nymph

b) The life cycle of the butterfly has four stages while the life cycle of the cockroach has three stages.

35)a) The leaves have appeared yet and it cannot make its own food so it needs the seed leaves to get food.

b) Water, oxygen and suitable temperature.

36)a) Plunger A could be pressed down while plunger B could not.

b) Air can easily be compressed and fixed while water cannot be compressed as it has a definite volume.

37)a) When the screen clip is screwed tightly, air cannot get out of the flask and as it takes up space thus, when the water is poured into the funnel, the water cannot push the air out of the flask.

37)b)The screw clip has to be unscrewed so that water can flow into the flask.

38)a)It must have the magnetic property to ensure the bar of soap does not drop into the sink.

b)The bar fixed to the wall of the kitchen must be a magnet as steel is a magnetic material so that is why the knives would not fall off the wall.

39)a)

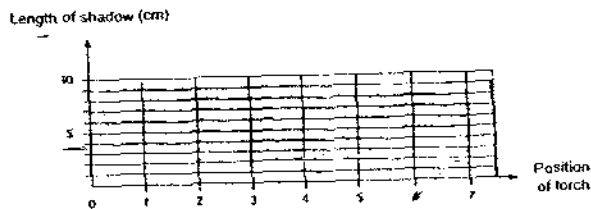

b)9cm.

c)

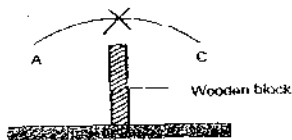

40)a)As the circular card and the white screen dice opaque objects light cannot pass through and so, a shadow was formed.

b)

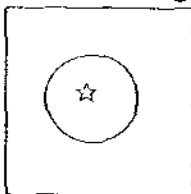

c)The shadow would become smaller.

41)a)Light travels in straight line.

b)D,B

42)a)Which material is a poor conductor of heat.

b)Heat from the beaker and the material, thus there was a heat in the beaker.

c)Material D.

43)a)It is in the liquid state.

b)When the rod is lifted from the liquid wax layer of liquid wax coats the rod, it will lose heat and thus changes into the solid state.

44a)Substance X.

b)When it was out in the sun for that period of time it lose the least heat.

183