

METHODIST GIRLS' SCHOOL (PRIMARY)

Founded in 1887



PRIMARY 4 END-OF-YEAR EXAMINATION 2009 SCIENCE

BOOKLET A

Total Time : 1 hour 45 minutes

INSTRUCTIONS TO CANDIDATES

Do not open the booklet until you are told to do so.

Follow all instructions carefully.

Answer all questions.

Name: _____ ()

Class: Primary 4 _____

Date: 12 October 2009

Booklet A	/ 50
Booklet B1	/ 18
Booklet B2	/ 22
Practical Test	/ 10
TOTAL	/ 100

This booklet consists of 18 printed pages.

Section A : (25 x 2 marks)

For each question, four options are given. Choose the most suitable option and shade your answer in the Optical Answer Sheet (OAS) provided.

1. Charmaine prepared the set-up as shown in the diagram below.

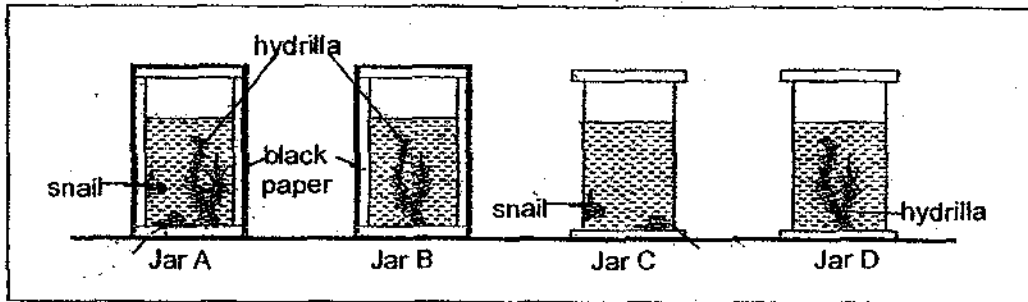

She filled four identical glass jars with some water and placed some snails or hydrilla into Jars B, C and D. In Jar A, she placed both, water snails and hydrilla. Jars A and B were then completely covered with black paper. The four jars were sealed and left to stand near a window for a week.

In which jar above would the level of carbon dioxide be the highest?

- (1) Jar A
(2) Jar B
(3) Jar C
(4) Jar D
2. Four rats were trapped inside a box for 1 hour. There was no fresh air entering the box. Which of the following shows the changes in the amount of gases in the box after 1 hour?

	Oxygen	Carbon dioxide	Water vapour
(1)	decrease	increase	increase
(2)	increase	decrease	increase
(3)	increase	decrease	decrease
(4)	decrease	increase	decrease

3. The table below shows the characteristics of some animals.

Characteristics	Animal A	Animal B	Animal C
Has fins	√	X	X
Has wings	X	√	√
Has beak	X	√	X
Has scales	√	X	X
Has three body parts	X	X	√
Has six legs	X	X	√
Has feathers	X	√	X

From the table above, what are Animal A, B and C likely to be?

	Animal A	Animal B	Animal C
(1)	Fish	Insect	Bird
(2)	Insect	Fish	Bird
(3)	Bird	Fish	Insect
(4)	Fish	Bird	Insect

4. The diagram below shows a system found in the human body.

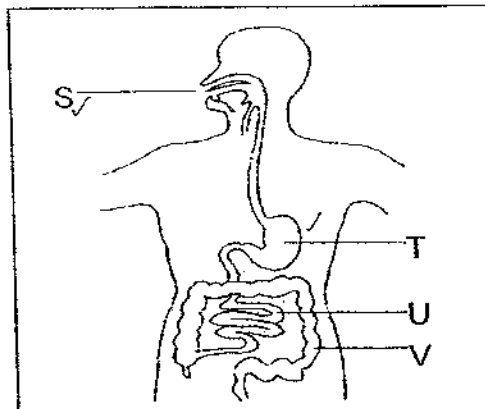

In which of the part/s above is/are digestive juice produced?

- (1) S only
- (2) T only
- (3) S, T and U
- (4) S, T, U and V

5. Animal X has the following characteristics:

- It lays eggs.
- It has a beak.
- It has a pair of wings.
- It has feathers on its body.

Which of the following shows the **correct** order of stages in the life cycle of the animal described above?

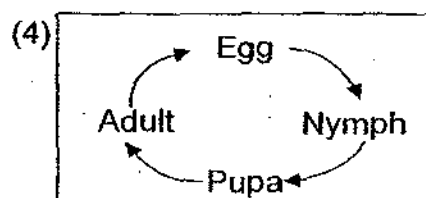
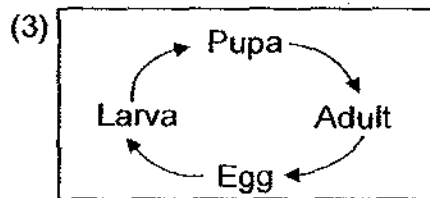
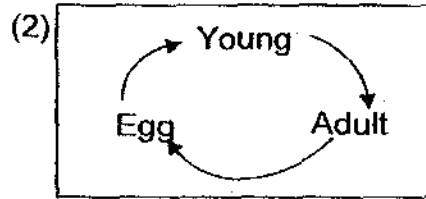
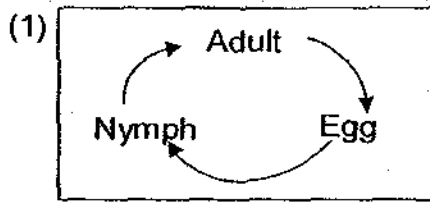

6. The flowchart below represents the human body systems working together to maintain a healthy body.

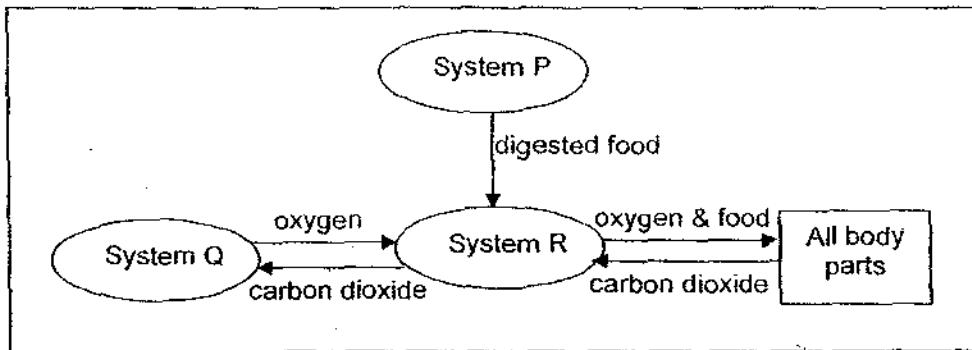

What do System P, Q and R above represent?

	System P	System Q	System R
(1)	Digestive System	Circulatory System	Respiratory System
(2)	Digestive System	Respiratory System	Circulatory System
(3)	Respiratory System	Circulatory System	Digestive System
(4)	Circulatory System	Digestive System	Respiratory System

7. The diagram below shows what happened in a leaf of a plant during photosynthesis.

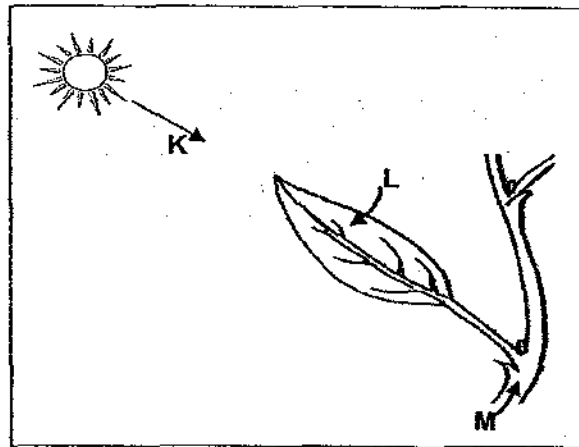



The arrows, K, L, and M indicate the substances that are needed by the leaf to photosynthesize.

Which of the following describes the things carried by the arrows correctly?

	Arrow K	Arrow L	Arrow M
(1)	It is a gas found in the air.	It is the liquid that is taken in by the roots of the plant.	It is a form of energy.
(2)	It is a form of energy.	It is a gas found in the air.	It is the liquid that is taken in by the roots of the plant.
(3)	It is a form of energy.	It is the liquid that is taken in by the roots of the plant.	It is a gas found in the air.
(4)	It is the liquid that is taken in by the roots of the plant.	It is a gas found in the air.	It is a form of energy.

8. Sarah conducted an experiment to find out at which temperature would mould grow best. She put equal-sized pieces of cheese into four clear plastic bags. She then left the bags in four different places where the temperature was monitored and kept constant.

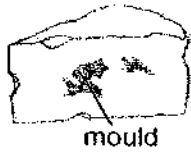
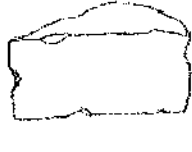
After two weeks, she recorded her observation in a table as shown below.

	Cheese in plastic bag 1	Cheese in plastic bag 2	Cheese in plastic bag 3	Cheese in plastic bag 4
Temperature where cheese was left	18°C	5°C	25°C	12°C
Condition of cheese after 2 weeks	 mould		 mould	 mould

Based on her observation above, which of the statements below **best** explains the relationship between temperature and the growth of mould?

- (1) Lower temperature promotes growth of mould.
- (2) As the temperature rises, the growth of mould lessens.
- (3) The temperature has no effect on the growth of mould.
- (4) As the temperature rises, the amount of mould increases.

9. Deborah collected four leaves A, B, C and D as shown below from her house garden.

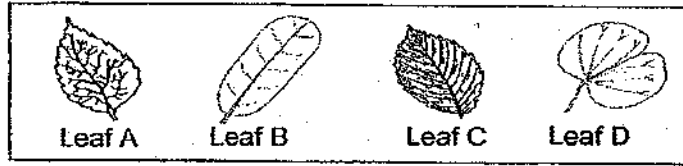

She then grouped the leaves in the table as shown below.

Group X	Group Y
Leaf A	Leaf B
Leaf C	Leaf D

Which one of the following would be the **most suitable** headings for Group X and Group Y?

	Group X	Group Y
(1)	Round shape	Oval shape
(2)	Parallel veins	Network veins
(3)	Toothed-edge	Smoothed-edge
(4)	Compound leaf	Single leaf

10. Study the flowchart below.

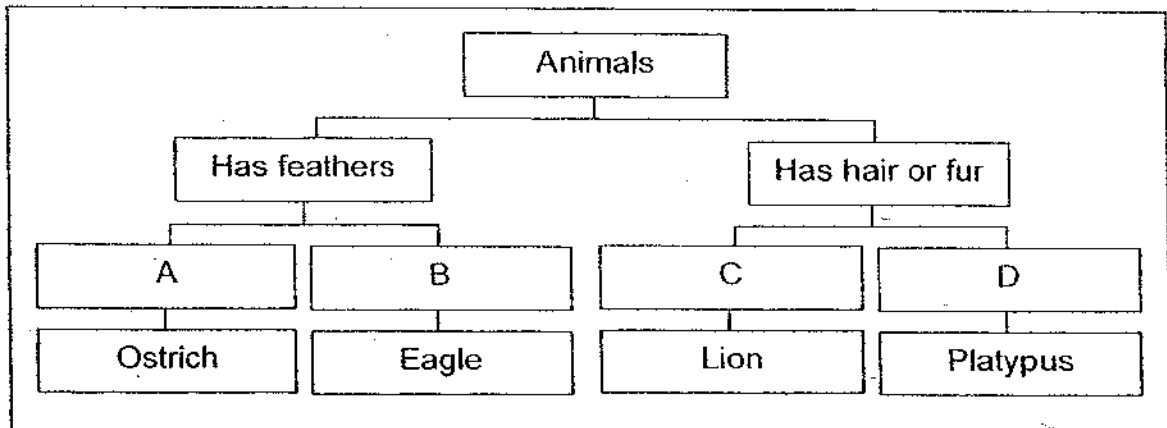

Which of the following sets would be the most suitable headings for A, B, C and D?

	A	B	C	D
(1)	Can fly	Cannot fly	Lay eggs	Give birth
(2)	Cannot fly	Can fly	Give birth	Lay egg
(3)	Lay eggs	Can fly	Cannot fly	Give birth
(4)	Cannot fly	Lay eggs	Give birth	Cannot fly

11. Which one of the graphs below shows the likely relationship between the number of stomata on the leaves of plants growing in deserts and its surrounding temperature?

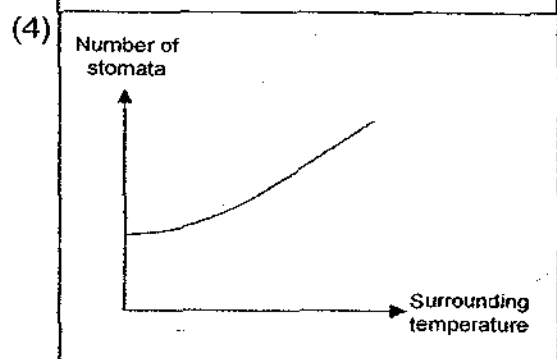
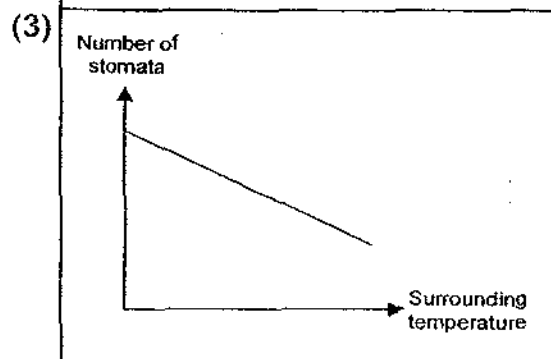
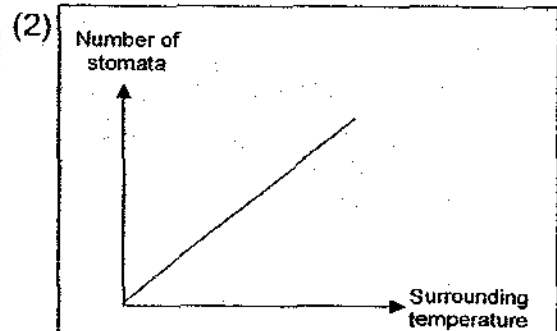
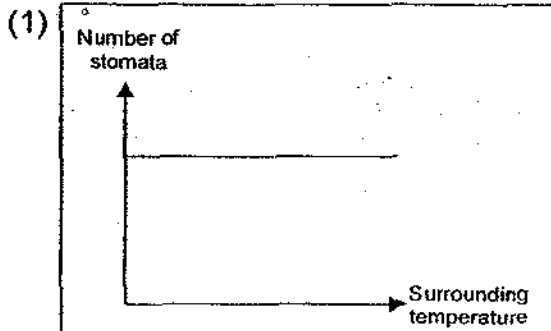

12. Four blood samples, W, X, Y and Z were taken from different parts of the blood vessels in the body. The graph below shows the amount of oxygen in each of these blood samples.

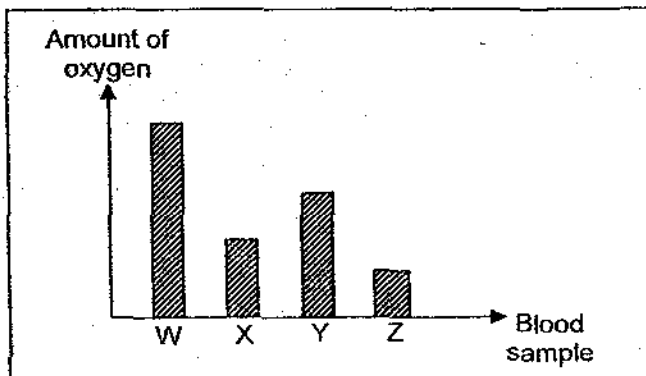

Which blood sample was most probably taken from blood vessels carrying blood from the lungs to the heart?

- (1) W
- (2) X
- (3) Y
- (4) Z

13. Study the flowchart below carefully.

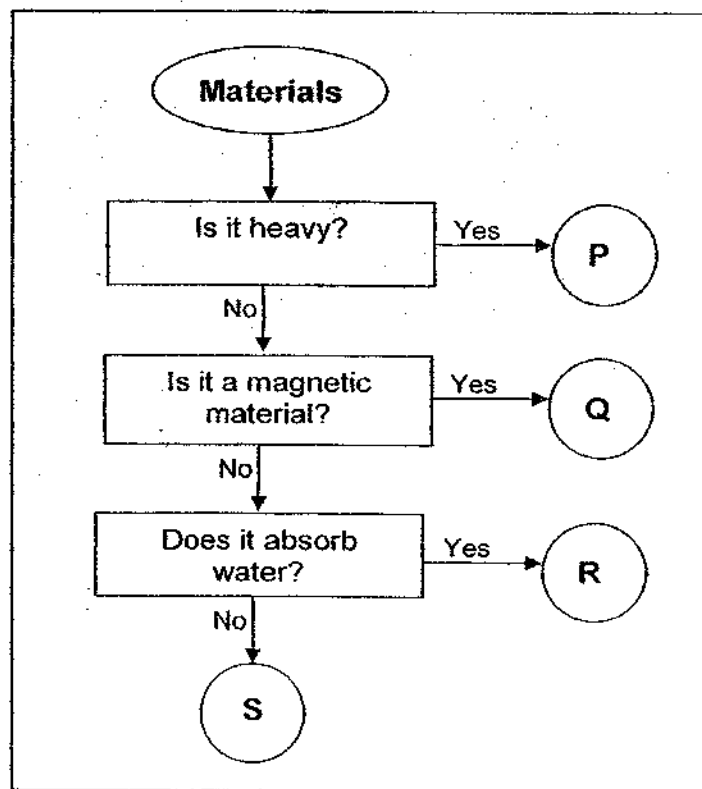

Which one of the following is a suitable material for making a raincoat?

- (1) P
- (2) Q
- (3) R
- (4) S

14. Magnet A was placed in a paper cup. The paper cup was then hung onto a retort stand by a spring. Another magnet, Magnet B was placed under the paper cup as shown in the diagram shown below.

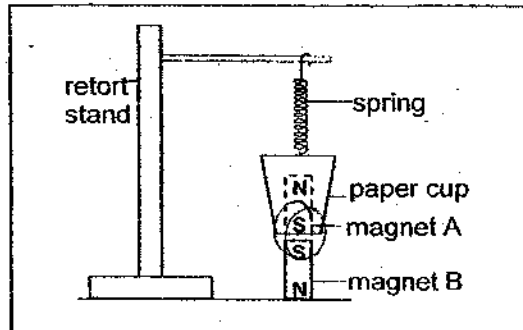

Which of the following will happen to the magnets and the spring?

- (1) The magnets will attract each other and the spring will stretch.
 - (2) The magnets will repel each other and the spring will compress.
 - (3) The magnets will repel each other but nothing will happen to the spring.
 - (4) Magnet B will be attracted to the paper cup and the spring will stretch.
15. The volume of an irregular-shaped stone can be obtained by measuring the volume of water displaced by the stone as shown in the diagram below.

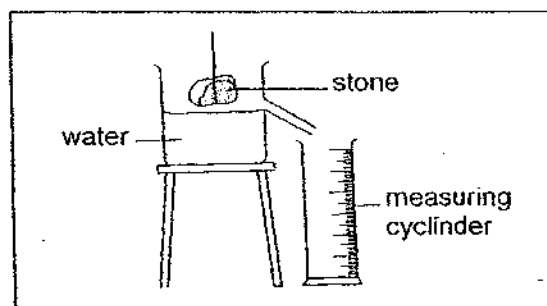

Observe the set-up carefully. Which one of the following **does not** explain why this displacement method can be used to find the volume of the stone?

- (1) Water has a fixed shape.
- (2) The stone can sink in water.
- (3) The stone does not have a regular shape.
- (4) Water flows and takes the shape of the container it fills.

16. The diagrams below show objects R and S when they were placed in containers of oil and water respectively.

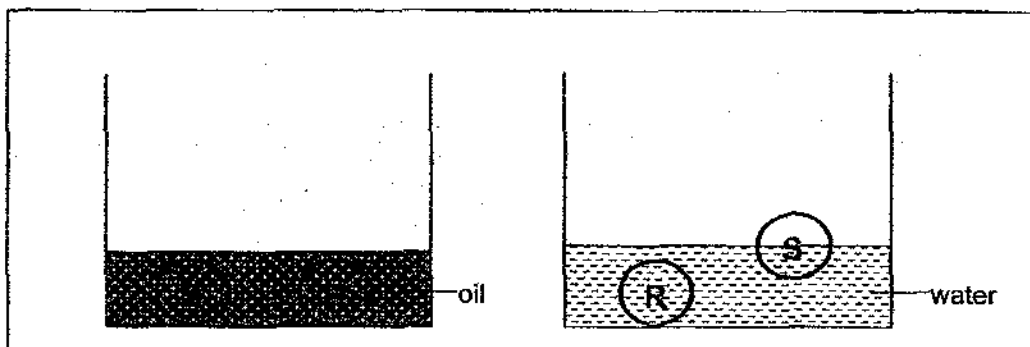

Oil floats on water. Which one of the following shows what happens when objects R and S were placed in a container containing both oil and water?

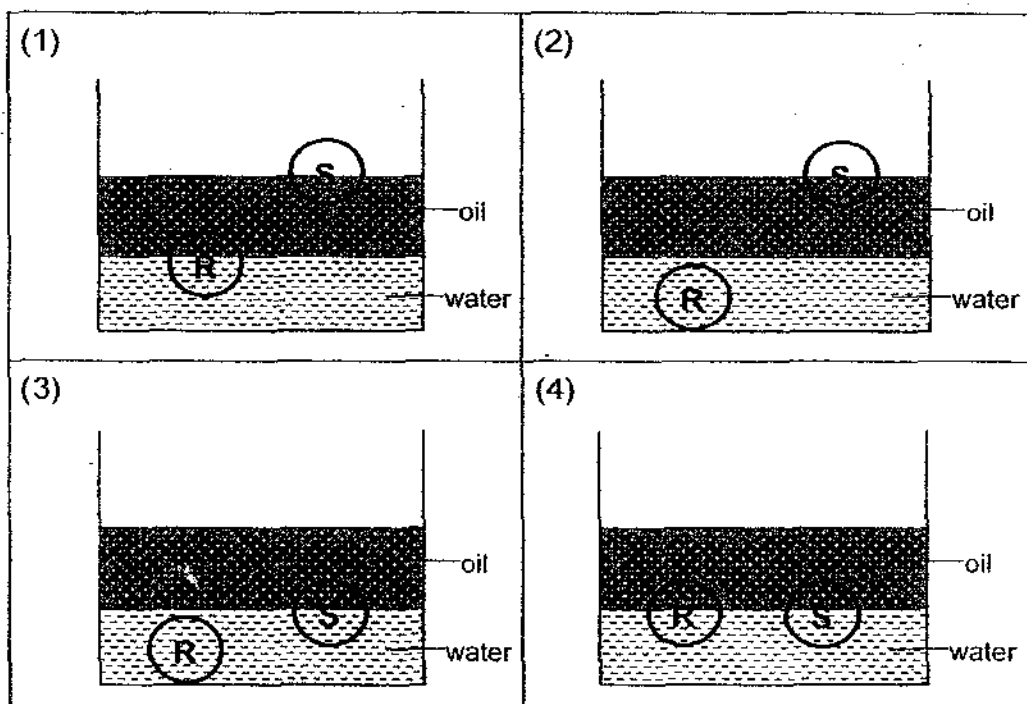

17. Sandy had 2 containers, X and Y. Both containers have the same mass. She filled Container X to the brim with water as shown in the diagram below.

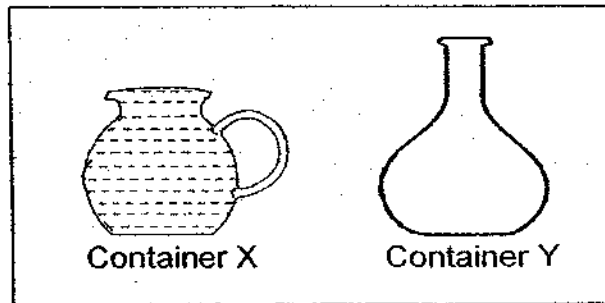

Which of the following statements **correctly** states what would happen if she were to pour all the water in Container X into Container Y? (Assuming that there was no spillage.)

- A : The water level will change and the shape of the water will change.
- B : The shape of the water will change and the mass of the water will change.
- C : The water level will change while the mass of the water will remain unchanged.
- D : The shape of the water will change while the mass of the water will remain unchanged.

- (1) A and B only
(2) C and D only
(3) A, B and C only
(4) A, C and D only

18. Study the diagram below.

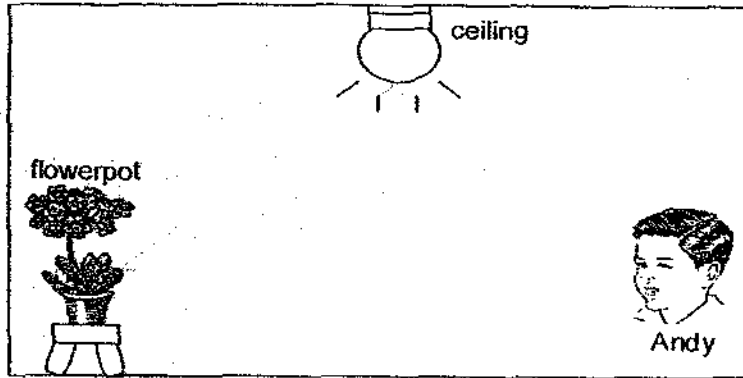

Andy is looking at the flowerpot in the room. The only light source in the room is the ceiling light.

Which of the following **correctly** shows the path of light in the room?

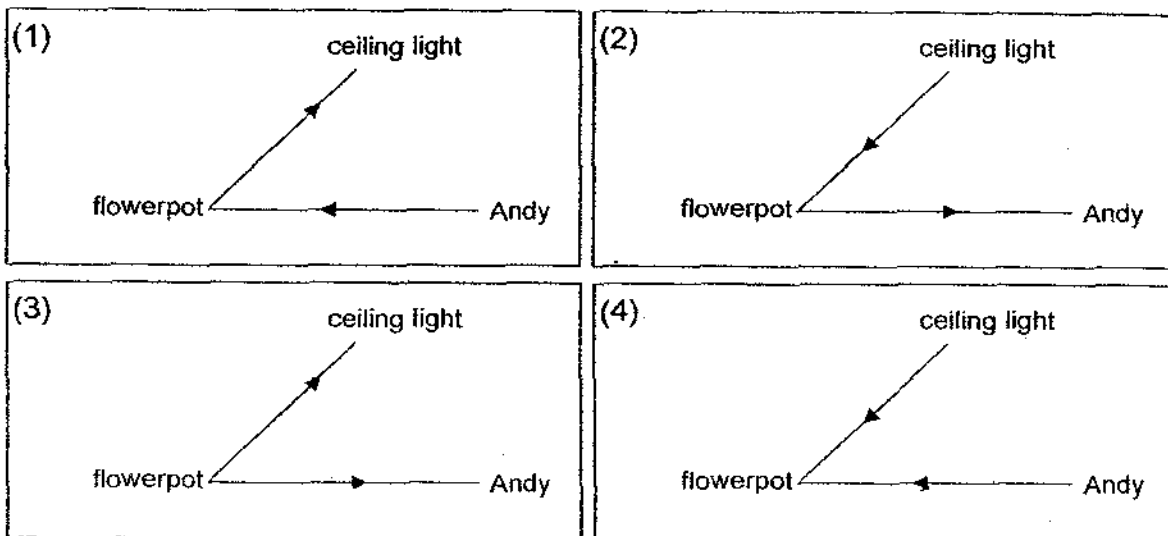

19. The diagram below shows four cars, A, B, C and D.

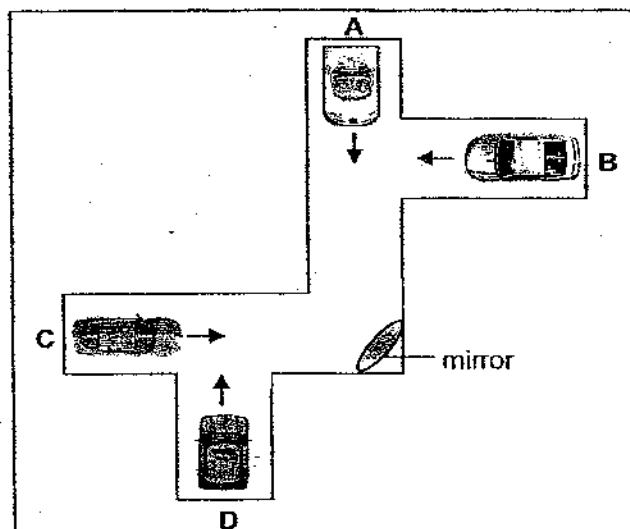

The four cars are travelling in the directions shown by the arrows. Which two drivers can see each other in the mirror?

- (1) A and B
- (2) B and C
- (3) C and D
- (4) A and C

20. Four similar beakers, A, B, C and D are placed on the same table. Each beaker is filled with water at the temperature as shown below.

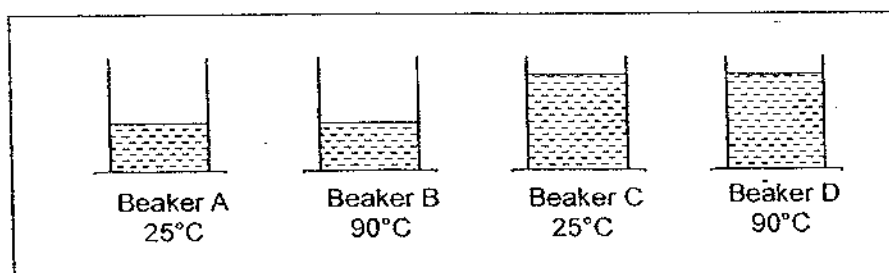

After ten minutes, which beaker contains water with the most heat?

- (1) Beaker A
- (2) Beaker B
- (3) Beaker C
- (4) Beaker D

For question 21 and 22, refer to the graph given below.

The graph below shows the changes in temperature of four beakers of water over a period of 15 minutes.

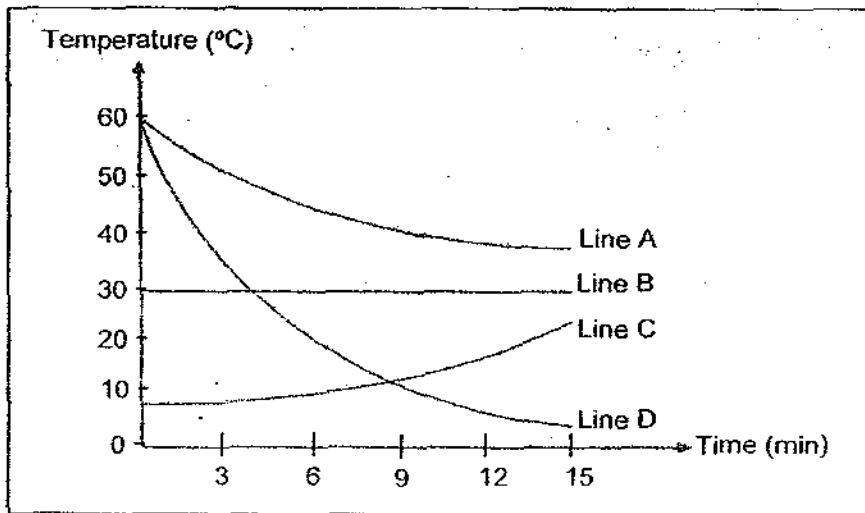

21. Which line in the graph above represents the temperature of a beaker of ice water that was left in a room?
- (1) Line A
 - (2) Line B
 - (3) Line C
 - (4) Line D
22. Line D represents the change in temperature of a beaker of water at 60°C. What was done to the beaker of water to result in this change in temperature?
- (1) A heated spoon was placed in the beaker of water.
 - (2) A burning candle was placed under the beaker of water.
 - (3) 100ml of boiling water was added into the beaker of water.
 - (4) 10 pieces of ice cubes were added into the beaker of water.

23. The diagram below shows two thin strips of metal made of different materials, X and Y. Material X is a good conductor of heat while Material Y is a poor conductor of heat. Both strips were heated for 20 minutes. The lengths and breadths of the metal strips before heating were 10 cm by 2 cm respectively.

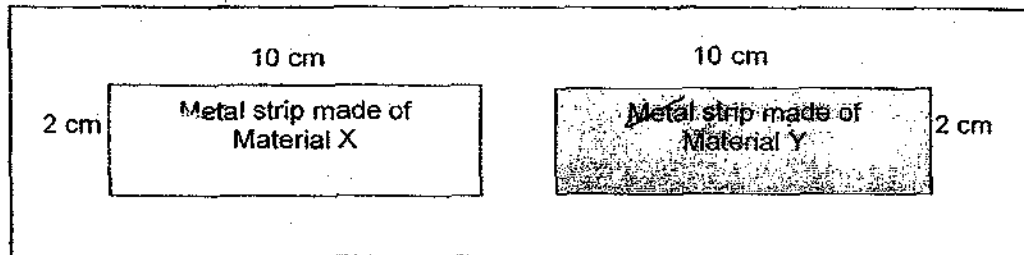

Which of the following shows the likely sizes of the metal strips after heating?

	Length and breadth of metal strip made of Material X respectively	Length and breadth of metal strip made of Material Y respectively
(1)	9 cm by 1 cm	9 cm by 1 cm
(2)	10 cm by 2 cm	14 cm by 4 cm
(3)	14 cm by 4 cm	10 cm by 1 cm
(4)	14 cm by 4 cm	11 cm by 3 cm

24. Esther poured some hot water with temperature of 80°C into a beaker. She then placed a metal spoon into the beaker of hot water for 5 minutes as shown in Diagram A below.

Later, she added some ice cubes into the beaker as shown in Diagram B.

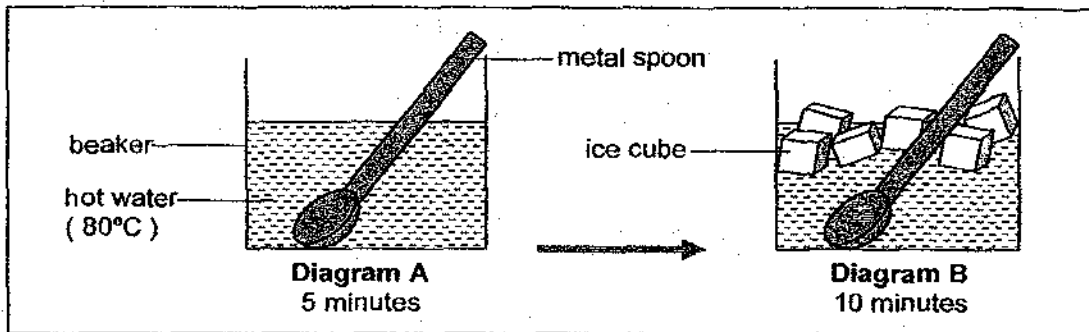

She observed the set-up for ten minutes. Then, she identified the things that had lost heat and the things that had gained heat into a table as shown below.

Which one of the following has Esther identified wrongly?

		First 5 minutes		Next 10 minutes	
		Gained Heat	Lost Heat	Gained Heat	Lost Heat
(1)	Beaker	✓			✓
(2)	Hot water		✓	✓	
(3)	Metal spoon	✓			✓
(4)	Ice cubes				✓

25. An equal amount of hot water at 90°C was poured into each of two similar metal containers, P and Q. Each container was wrapped with different materials, an aluminium foil and a bubbled plastic sheet as shown in the diagram below. The containers were then left on the table to cool for one hour.

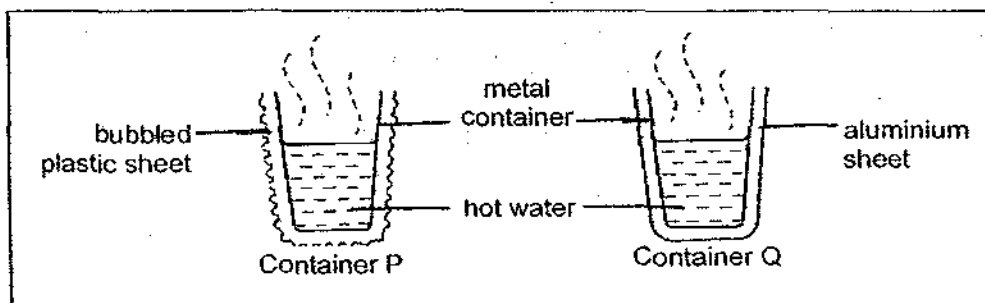

The initial and final temperatures of water in both containers were measured and recorded in the table as shown below.

Container	Initial temperature (°C)	Final temperature (°C)
P	90	75
Q	90	45

Which of the following sentence/s correctly explain/s why the water in Container P cooled down more slowly?

- A : There was no wind.
- B : Plastic is a poor conductor of heat.
- C : The water in both containers was too hot.
- D : The air in the bubbled plastic sheet is not a good conductor of heat.

- (1) A only
- (2) B only
- (3) B and D only
- (4) B, C and D only

METHODIST GIRLS' SCHOOL (PRIMARY)

Founded in 1887



PRIMARY 4 END-OF-YEAR EXAMINATION 2009 SCIENCE BOOKLET B1

Total Time : 1 hour 45 minutes

INSTRUCTIONS TO CANDIDATES

Do not open the booklet until you are told to do so.

Follow all instructions carefully.

Answer all questions.

Name: _____ ()

Class: Primary 4. _____

Date: 12 October 2009

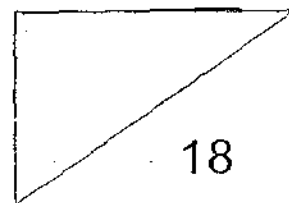

This booklet consists of 6 printed pages.

Section B1 : (18 marks)

Write the answers in the blanks provided.

26. The following flowchart shows how organisms are classified. Study the chart carefully.

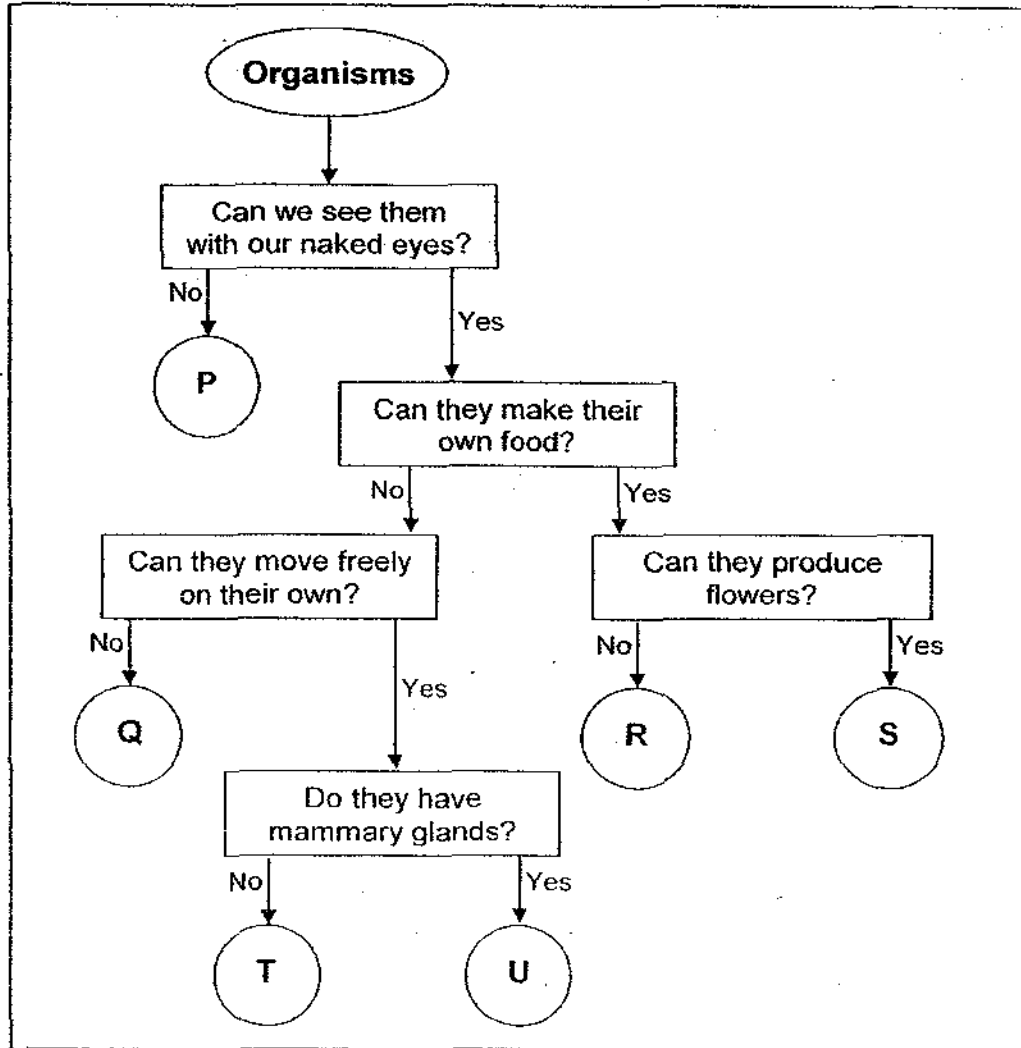

Write the letters P, Q, R, S, T and U in the table below to match the group they belong to. (3m)

	Group	Letters
(a)	Fish	
(b)	Fungi	
(c)	Mammals	
(d)	Micro-organisms	
(e)	Flowering plants	
(f)	Non-flowering plants	

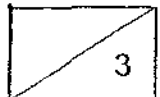

27. Sally wanted to find out how the presence of roots of a plant affects the amount of water taken in by the plants. She set up an experiment as shown in the figure below.

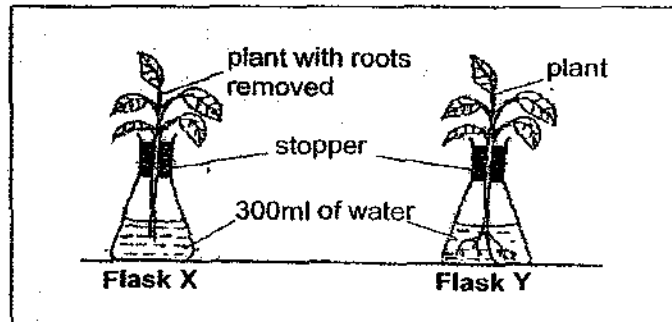

Flask X and Y were left in the open for 5 days. The volume of water in the flask was measured at 11 p.m. each day and recorded as shown in the table below.

	Volume of water in Flask X	Volume of water in Flask Y
Monday	300 ml	300 ml
Tuesday	295 ml	285 ml
Wednesday	286 ml	261 ml
Thursday	272 ml	246 ml
Friday	263 ml	234 ml

- (a) What conclusion could Sally draw from the data in the table? (1m)

- (b) What was the volume of water taken in by the plant in Flask Y on Friday? (1m)

28. The diagram below shows a leaf.

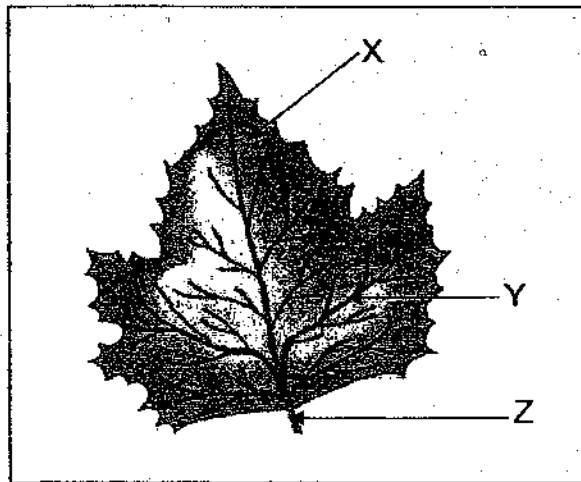

(a) Name the parts of the leaf labelled X, Y and Z. (1m)

(i) X: _____

(ii) Y: _____

(iii) Z: _____

(b) How is the part labelled Y similar to the blood vessels in your body? (1m)

(c) What is the main function of a leaf? (1m)

29. A cut celery stalk was put into a beaker of red-coloured water as shown in the diagram below.

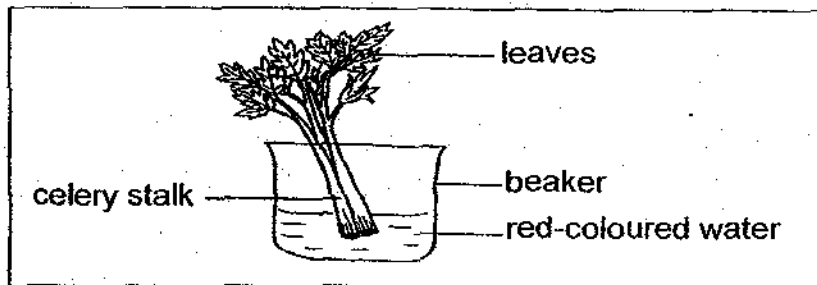

- (a) What happened to the leaves after a week? (1m)

- (b) What is the function of the stem in the experiment above? (1m)

- (c) Other than the one you have mentioned in (b), give another function of the celery stalk. (1m)

30. The diagram below shows the life cycle of a moth.

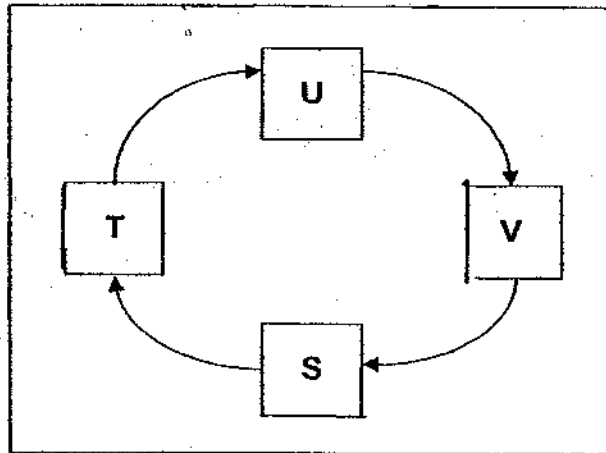

(a) If Letter V represents the adult stage of a moth, which letter represents the pupal stage correctly? (1m)

(b) Give one difference in characteristics between stages T and U. (1m)

(c) At which stage (S, T, U or V) is it a pest to farmers? Give a reason for your answer. (1m)

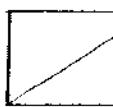

31. Read the following statements and put a tick (✓) if the statement/s is/are true and cross (X) if the statement/s is/are false in the column given below. (2m)

	Statements	True or False
(a)	Water is absorbed in the small intestine.	
(b)	Digestion begins in the mouth and ends in the stomach.	
(c)	Digestion takes place in every part of the organ in the digestive system.	
(d)	Food is broken down into simpler substances that can be absorbed by the body.	

32. The diagram below shows the human skull.

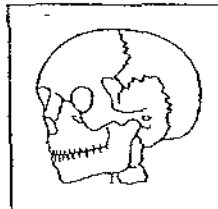

- (a) What is the function of the human skull? (1m)
- _____
- (b) Is the skull designed for movement? Give a reason for your answer. (1m)
- _____
- _____

METHODIST GIRLS' SCHOOL (PRIMARY)

Founded in 1887



PRIMARY 4 END-OF-YEAR EXAMINATION 2009 SCIENCE BOOKLET B2

Total Time : 1 hour 45 minutes

INSTRUCTIONS TO CANDIDATES

Do not open the booklet until you are told to do so.
Follow all instructions carefully.
Answer all questions.

Name: _____ ()

Class: Primary 4. _____

Date: 12 October 2009

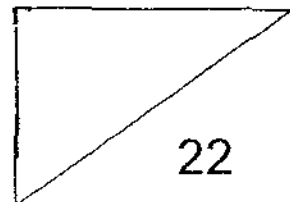

This booklet consists of 8 printed pages.

Section B2 : (22 marks)

Write the answers in the blanks provided.

33. Three identical candles, A, B and C were used in the set-up below. They were lit at the same time.

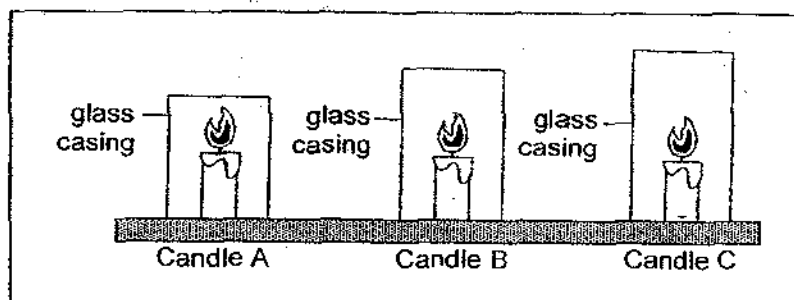

- (a) Arrange in ascending order how fast the candle would burn. (1m)

- (b) Explain why there was a difference in the burning time of the three candles. (1m)



34. An experiment was carried out to find out which type of cup was better for keeping coffee hot. An equal amount of hot coffee was poured into a plastic cup and a styrofoam cup of the same size. The temperatures of the coffee in both cups were taken every 5 minutes. The results are shown in the two separate graphs below.

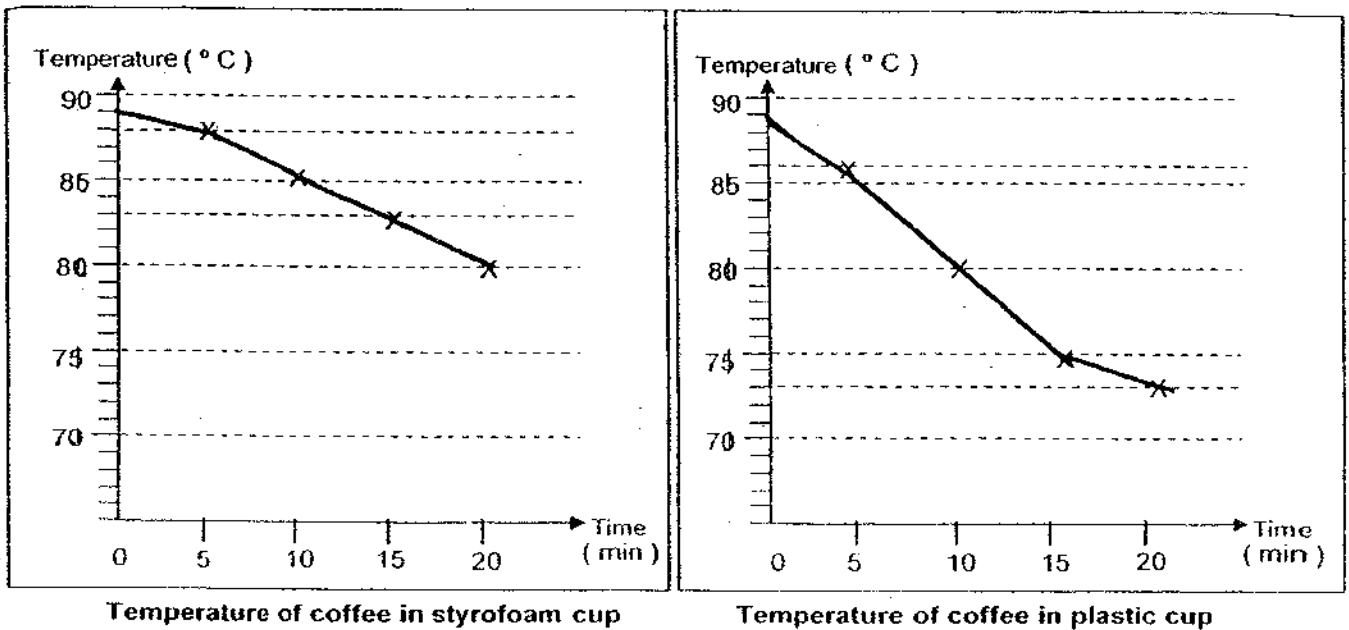

- (a) Based on the graphs above, which cup would you choose if you want your coffee to stay hot longer? (1m)

- (b) After 20 minutes, what was the temperature of the coffee in the plastic cup? (1m)

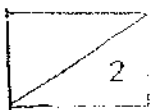

35. Sally set up an experiment as shown in the diagram below.

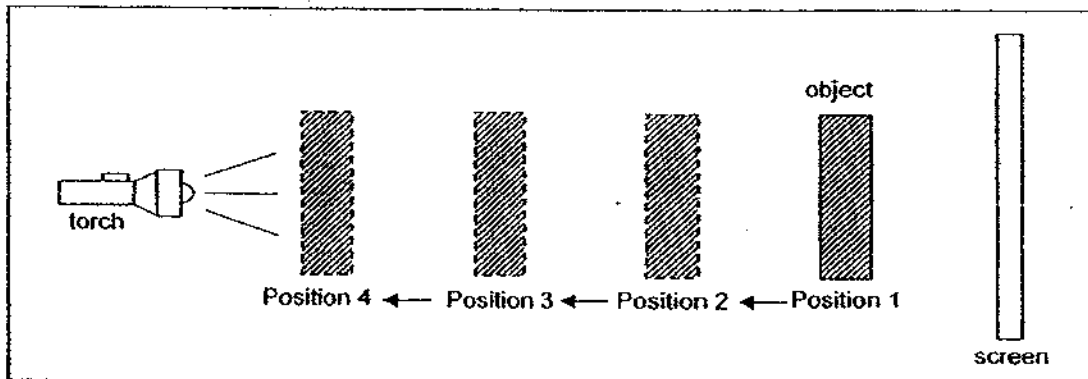

Fixing the torch and the screen, she moved the object ^{further away from} towards the screen from position 1 to 4. Then she measured the length of the shadow at each position and plotted a graph to show her results.

- (a) In the box provided below, complete the graph to show the relationship between the length of the shadow and the position of the object by drawing in the bars correctly. (1m)

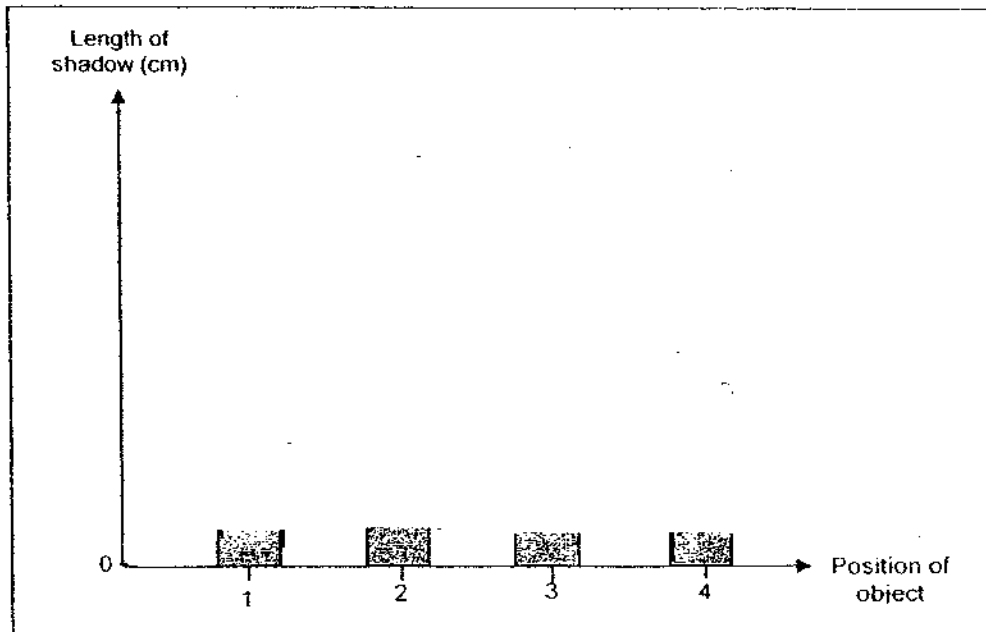

- (b) What is the relationship between the position of the object and the length of its shadow? (1m)

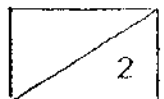

36. When an object was placed between the light source and the white screen, a shadow was seen on the white screen as shown below.

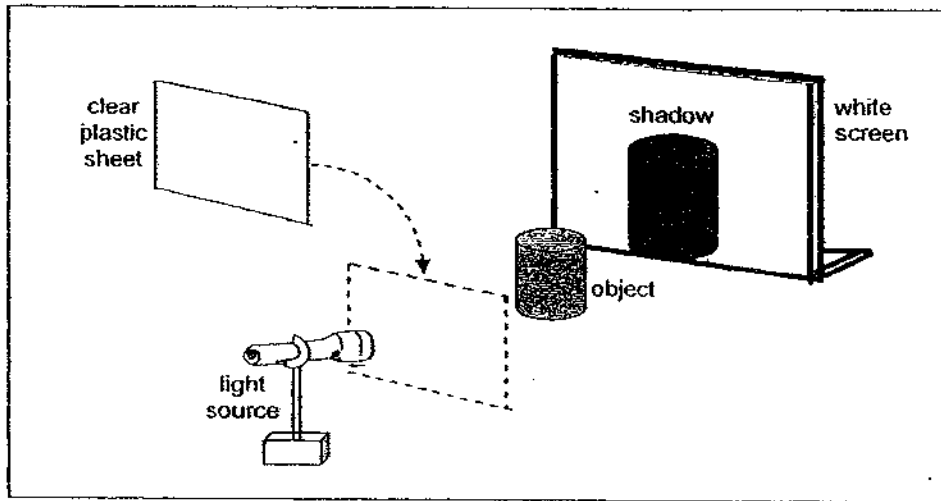

Alina wanted to find out if the colour of the clear plastic sheet placed in front of the light source would affect the colour of shadow formed. She conducted the experiment by using a clear red plastic sheet first, followed by a clear yellow plastic sheet and then a clear blue plastic sheet. Then, she recorded her observations in the table as shown below.

Colour of plastic sheet	Colour of shadow formed
Red	Black
Yellow	Black
Blue	Black

- (a) What was the variable that Alina change to conduct her experiment?

- (b) Give the 2 variables that Alina needed to keep the same to make her test fair? (2m)

(i) _____

(ii) _____

- (c) What conclusion could Alina make from the observations? (1m)

37. David inverted a plastic cup into a basin of water as shown in the diagram below.

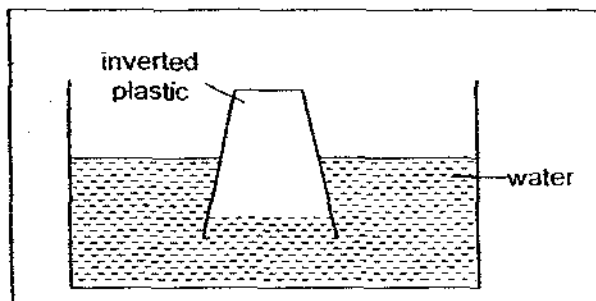

As he pushed the plastic cup into the basin of water, he observes that the water in the basin **did not completely** enter the cup.

- (a) What could David conclude from the experiment above? (1m)

Then David made a big hole at the base of the inverted cup and pushed the cup into the basin of water again as shown in the diagram below.

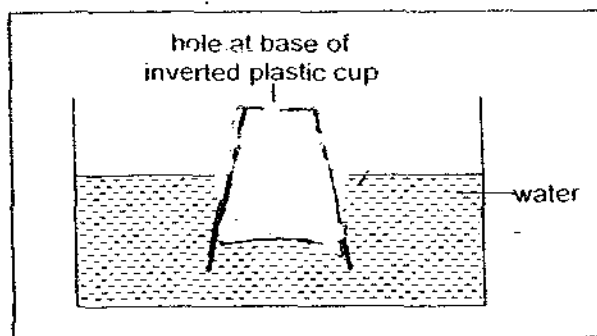

- (b) Draw the new water level in the cup in the diagram above. (1m)

- (c) Explain your answer in (b). (1m)



38. Study the flowchart below.

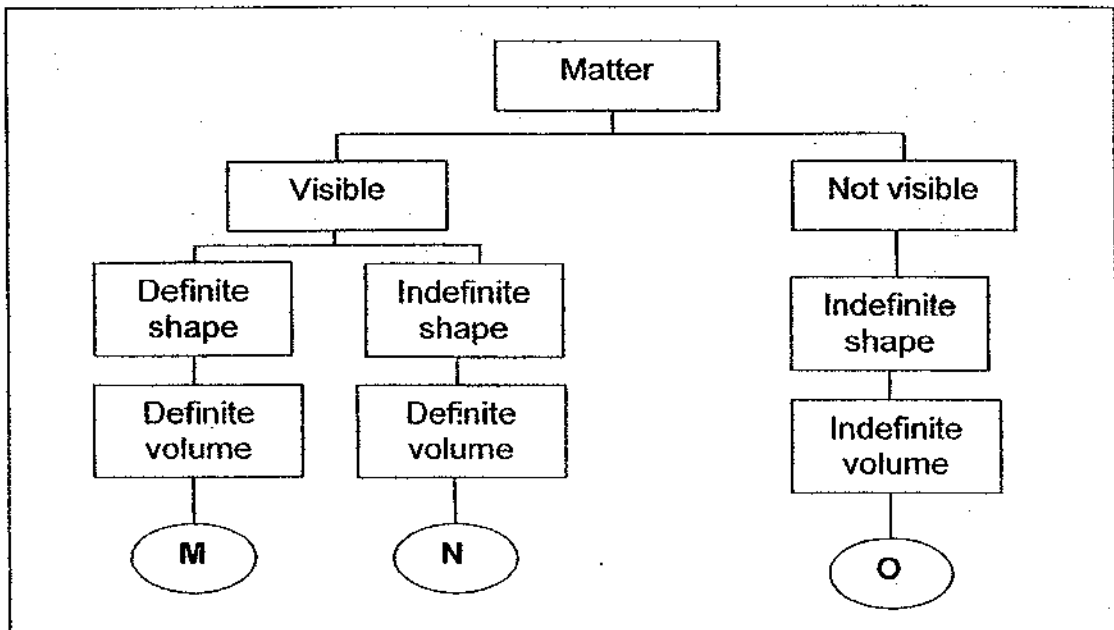

(a) What are the characteristics of N? (1m)

(b) N and O are both matter. Give another similarity of N and O. (1m)

(c) In what state is O in? (1m)

(d) In which group, M, N or O would you place a sponge under? (1m)

39. The diagram below shows what happened to four identical bar magnets when they are hung on a pole. The ends of the bar magnets are marked P to W.

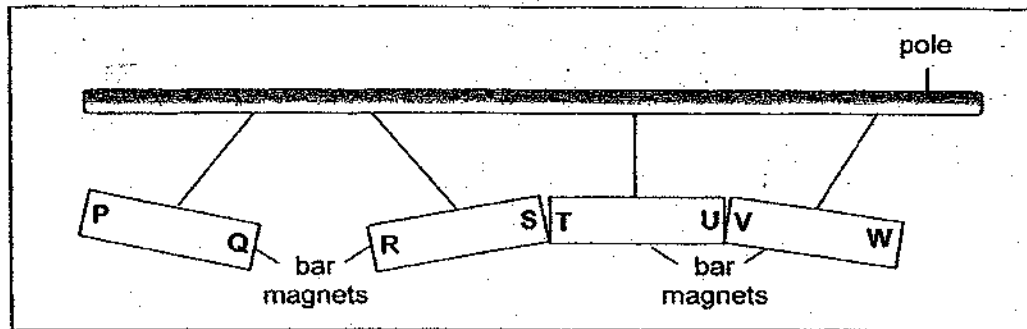

The diagram below shows a possible arrangement of the four bar magnets.

Write the letters, P, Q, R, U, V and W in the correct poles of the magnets. The letter T and S are done for you. (3m)

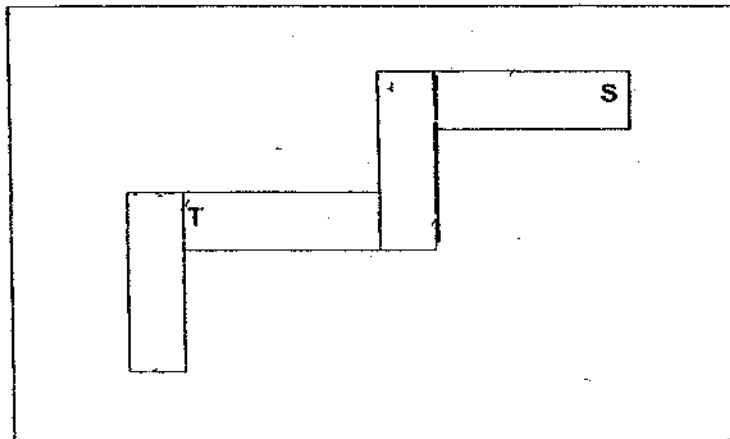

40. Rachel filled two identical containers, A and B with the same amount of water, but of different temperatures as shown in the diagram below.

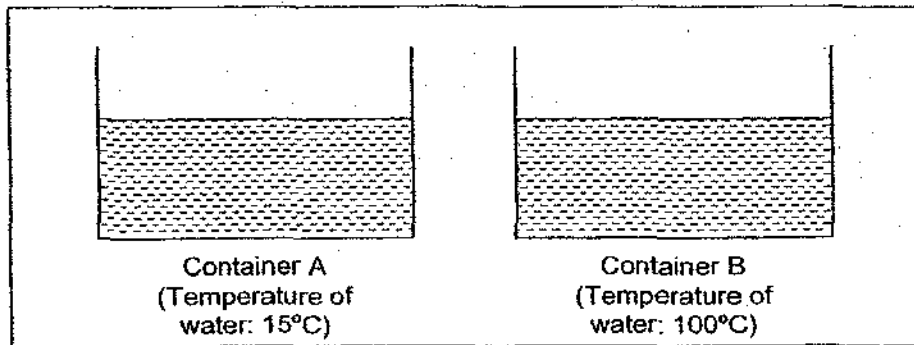

She was given the following materials.

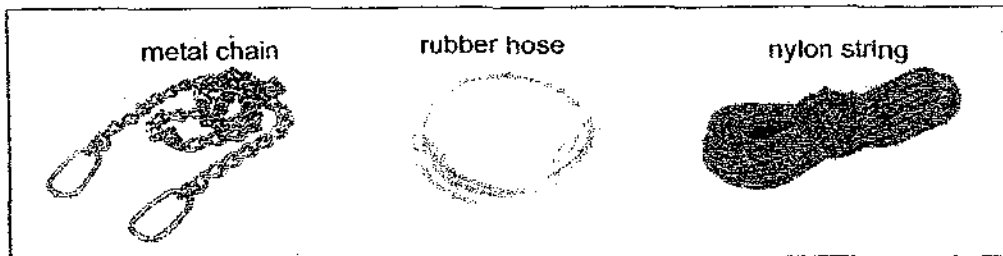

- (a) In the box below, **draw** a diagram using **only one** of the materials that was given to Rachel above, to show how heat could be transferred from one container to another, without pouring or transferring any water over. (1m)

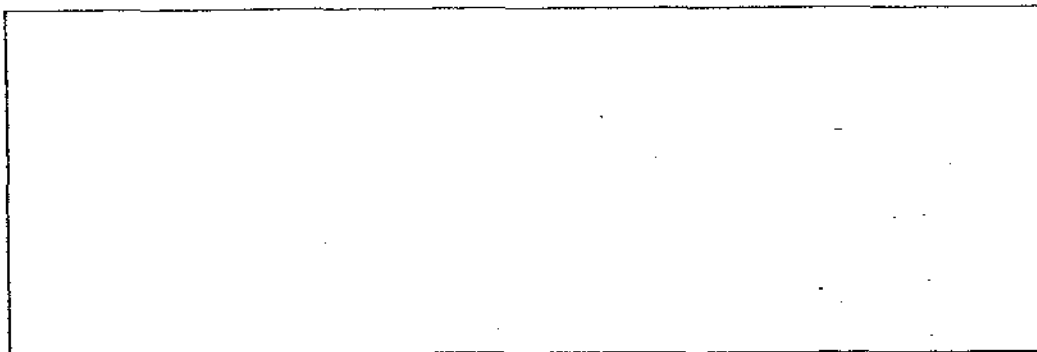

- (b) Explain how heat is transferred between the two containers in the method you drew above. (1m)

ANSWER SHEET

EXAM PAPER 2009

**SCHOOL : MGS PRIMARY
SUBJECT : PRIMARY 4 SCIENCE**

TERM : SA2

Q1	Q2	Q3	Q4	Q5	Q6	Q7	Q8	Q9	Q10	Q11	Q12	Q13	Q14	Q15	Q16	Q17
1	1	4	3	2	2	2	4	3	2	3	1	4	2	1	3	4

Q18	Q19	Q20	Q21	Q22	Q23	Q24	Q25
2	4	4	3	4	4	2	3

26)a)T b)Q c)U d)P e)S f)R

27)a)The presence of roots allow the plant to take in more water.
b)12ml

28)a)i)leaf blade ii)leaf veins iii)leaf stalk
b)If transport the water and food to the leaf just like the blood vessels transport minerals and oxygen to other parts of the body.
c)To photosynthesize.

29)a)They funned red.
b)It transport water to the other parts of the plant.
c)It is to store food.

30)a)U.
b)In stage T, the moth eats and moults a lot but in stage U, it does not eat or moult at all.
c)T. It is because it eats the crops that the farmer grows.

31)a)X b)X c)X d)✓

32)a)To protect the brain.
b)No, because there are no movable joints.

33)a)Candle A, B, C.

b)It is because fire needs oxygen to burn. So, candle C has more oxygen, therefore, it can burn longer not like candle B and A.

34)a)Styrofoam cup.

b)73°C

35)a)

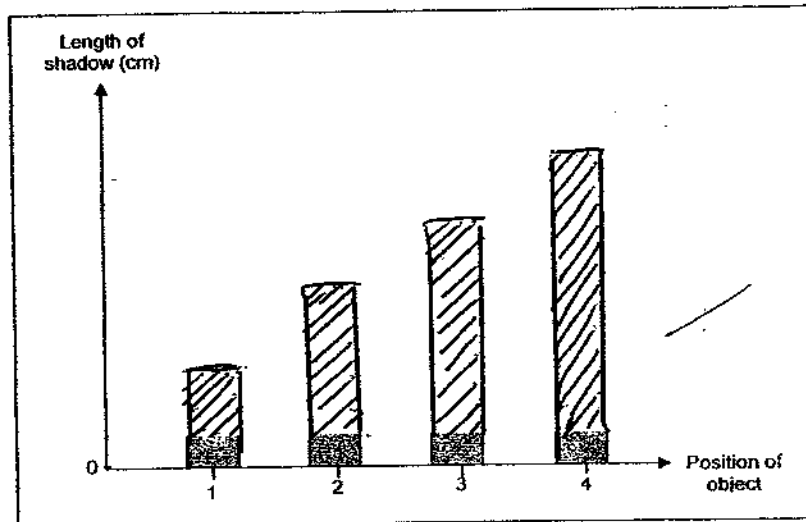

b)The further the object is from the screen, the longer the shadow.

36)a)The colour of the plastic sheet.

b)i)The colour of the screen.

ii)The amount of light given out from the light source.

c)The colour of the plastic sheet does not affect the colour of the shadow.

37)a)The air inside the cup is occupying the space inside so the water cannot go in.

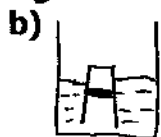

c)It is because when the cup was inverted, the air inside was still occupying the space. So, if the air was let out, the water inside will be able to enter the cup.

38)a)It is visible it has an indefinite shape and has a definite volume.

b)Both have an indefinite shape.

c)Gas.

d)M.

39)

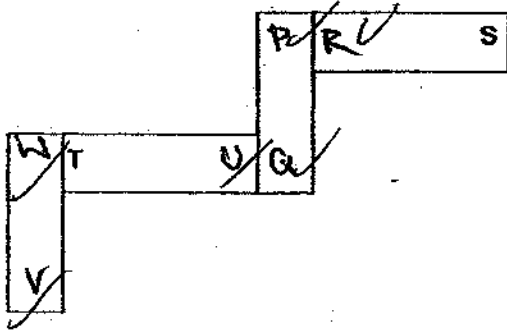

40)a)

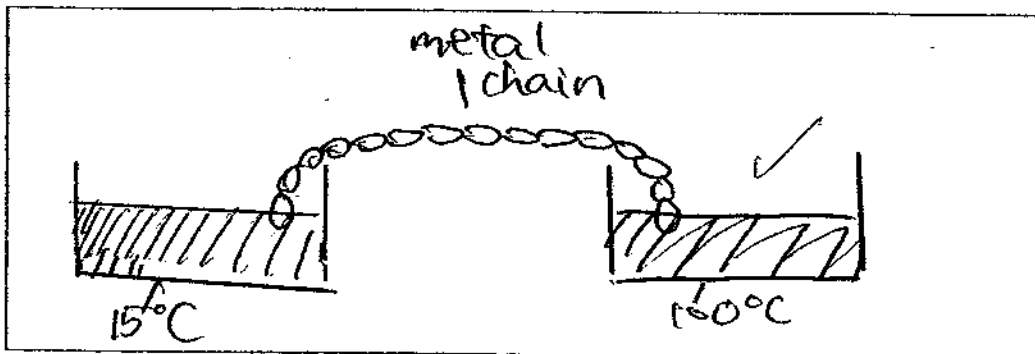

b) Heat is transferred from the hotter, hotter container to the cooler contain through the metal chain, which is a good conductor of heat.