



NAN HUA PRIMARY SCHOOL
SEMESTRAL ASSESSMENT 2 – 2009
PRIMARY 4

SCIENCE

BOOKLET A

30 Multiple Choice Questions (60 marks)

Total Time for Booklets A and B : 1 hour 45 minutes

INSTRUCTIONS TO CANDIDATES

1. Write your name and index number in the space provided.
2. Do not turn over the page until you are told to do so.
3. Follow all instructions carefully.
4. Answer all questions.
5. Shade your answers in the Optical Answer Sheet (OAS) provided.

Marks Obtained

Booklet A		/ 60
Booklet B		/ 40
Total		/100

Name: _____ ()

Class: P 4 _____

Date : 29 October 2009

Parent's Signature: _____

Section A: (30 x 2 marks = 60 marks)

For each question from 1 to 20, four options are given. One of them is the correct answer. Make your choice (1, 2, 3 or 4). Shade the correct oval (1, 2, 3 or 4) on the Optical Answer Sheet.

1. Y is made from a material that comes from plants and is opaque. Which one of the following is Y?

- 1) Silk scarf
- 2) Wool sweater
- 3) Tracing paper
- 4) Vanguard sheet

2. The following diagram shows a laboratory thermometer, which one of the following arrows points to the part where the alcohol is stored?

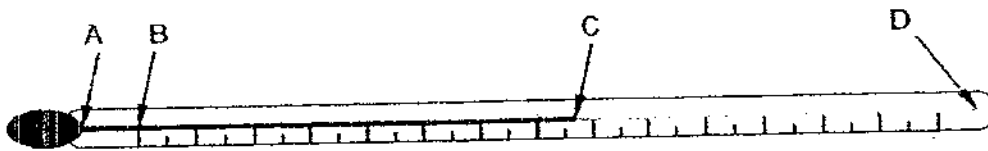

- 1) A
- 2) B
- 3) C
- 4) D

3. Mary heated a beaker of water and recorded the temperature change in the graph shown below. At one point in the experiment, she added some ice cubes into the beaker of water.

At which point of the graph shows that the ice cubes were added to the beaker of water?

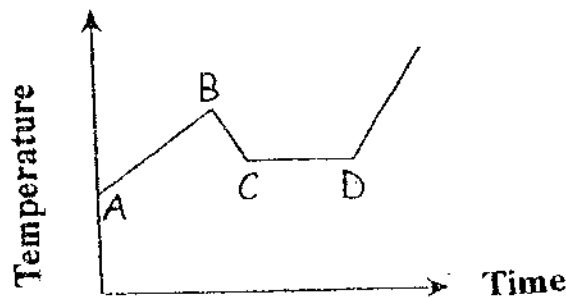

- 1) A
- 2) B
- 3) C
- 4) D

4. When a tadpole becomes an adult frog, what changes does it go through?

- A: Appearance
- B: Feeding habits
- C: Method of breathing

- 1) A and B only
- 2) A and C only
- 3) B and C only
- 4) A, B and C

5. What is the function of the part labelled 'X'?

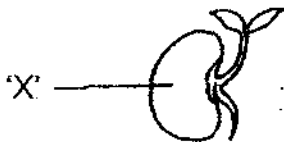

- 1) It gives the young seedling support.
- 2) It makes food for the young seedling.
- 3) It traps sunlight for the young seedling.
- 4) It provides the young seedling with stored food.

6. Peter's basketball was filled with air but he still could pump more air into it. The basketball did not become bigger. It became harder instead. What property does it show about air?

- 1) Air takes up space.
- 2) Air can be compressed.
- 3) Air has a definite volume.
- 4) Air has no definite volume.

7. What are the common characteristics of oxygen, glass and plastic?

- A: They have mass.
- B: They have a definite shape.
- C: They have a definite volume.

- 1) A only
- 2) A and C only
- 3) B and C only
- 4) A, B and C

8. Which of the following statements about our skeletal and muscular system is false?

- 1) They give the body its shape.
- 2) They pump blood to all parts of the body.
- 3) They allow the body to move by having joints.
- 4) They protect the important organs inside the body.

9. Which of the following shows the correct sequence of food digestion?

- 1) Mouth → Gullet → Stomach → Small intestine → Large intestine
- 2) Mouth → Gullet → Stomach → Large intestine → Small intestine
- 3) Gullet → Stomach → Mouth → Small intestine → Large intestine
- 4) Stomach → Small intestine → Gullet → Large intestine → Mouth

10. Which part of the magnet has the weakest magnetic force?

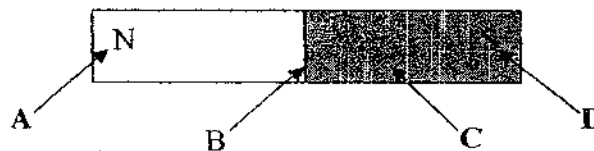

- 1) A
- 2) B
- 3) C
- 4) D

11.

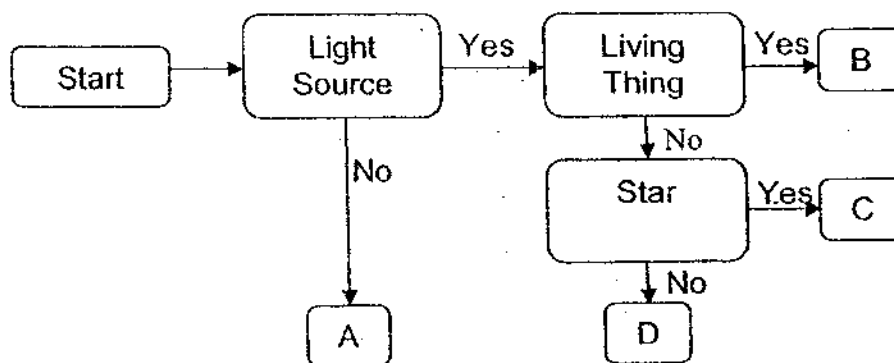

Which of the following best represent A, B, C and D respectively?

	A	B	C	D
1)	Photograph	Firefly	Moon	Fire
2)	Photograph	Dragonfly	Sun	Moon
3)	Pencil	Firefly	Sun	Lightning
4)	Pencil	Moon	Lightning	Sun

12. Why are reflectors placed on roads?

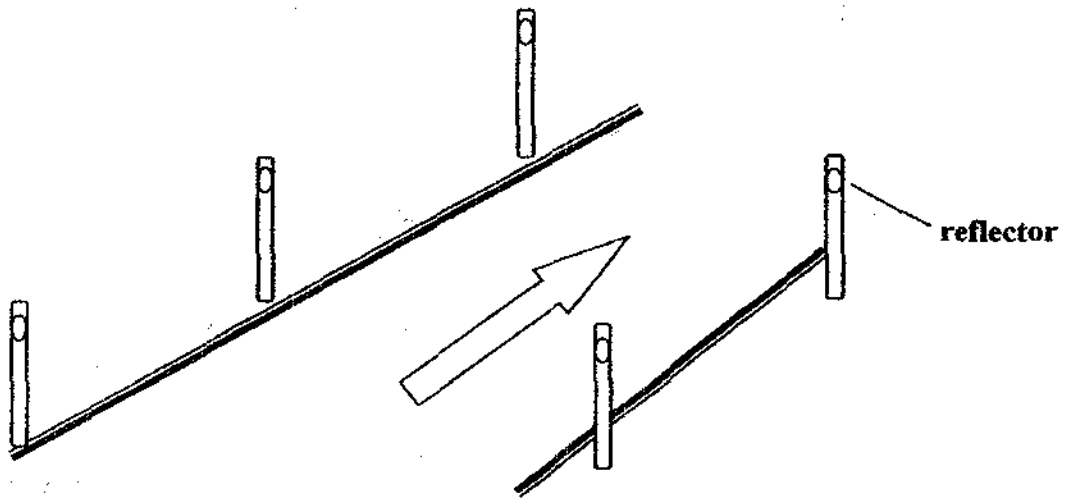

They are placed on the roads to _____

- 1) absorb the Sun's energy
- 2) produce glittery roads so that they are attractive to look at
- 3) reflect light at night so that the lanes can be spotted easily
- 4) enable us to see when the car's headlamps are not working

13. Shadows cast by the Sun change in length and position at different times of the day. Which of the following shows the shadow being cast at 5.00 pm?

1)

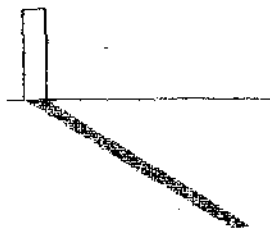

2)



3)

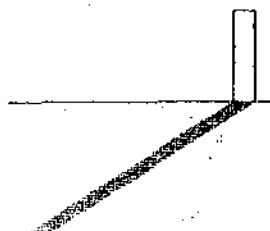

4)

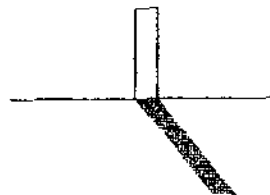

14. The picture below shows a metal ball and ring apparatus. The ring was just big enough for the ball to pass through at the start of the experiment.

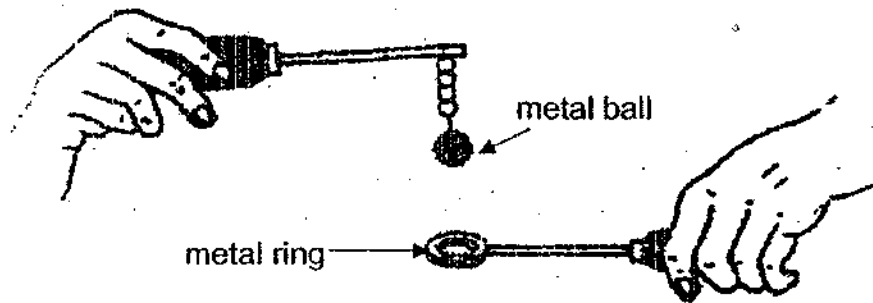

What should be done to the metal ball and ring apparatus to prevent the ball from passing through the ring?

- 1) The ring should be dipped into hot water.
 - 2) The ball should be dipped into cold water.
 - 3) The ring should be heated over a bunsen burner.
 - 4) The ball should be heated over a bunsen burner.
15. The diagram below shows a metal kettle.

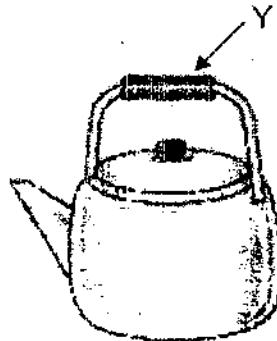

Which one of the following materials and its stated property is most suitable to make the part labelled 'Y'?

- 1) Metal should be used because it is a good conductor of heat.
- 2) Plastic should be used because it is a good insulator of heat.
- 3) Metal should be used because it is more durable than plastic.
- 4) Plastic should be used because it allows light to pass through it.

16. Study the classification chart below.

Group A	Group B
Frog	Giraffe
Housefly	Grasshopper
Mealworm beetle	Goldfish

What one of the following best represents Group A and Group B respectively?

	Group A	Group B
1)	Insects	Not insects
2)	Lay eggs	Give birth to young alive
3)	Have a 4-stage life cycle	Have a 3-stage life cycle
4)	Have young that do not resemble their parents	Have young that resembles their parents

17. The following diagrams show the development of a fertilized hen's egg into a chick. Choose the arrangement of the diagrams that will correctly show the stages of development.

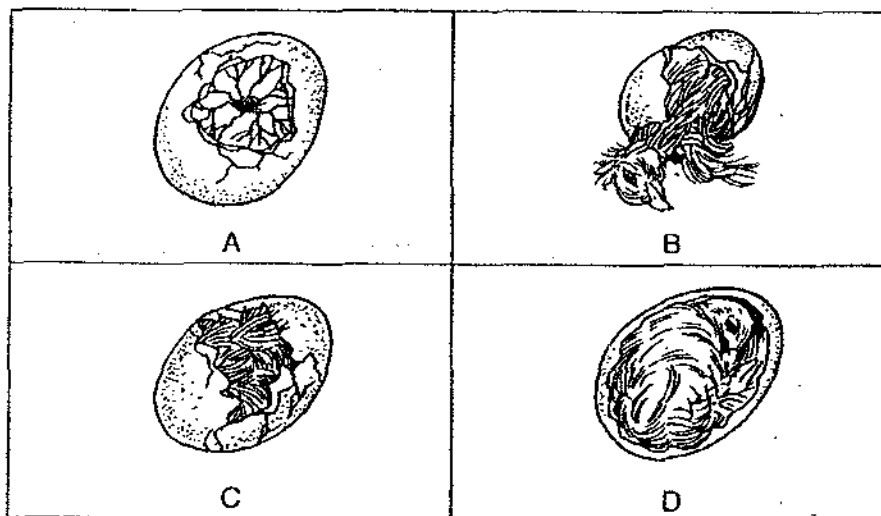

- 1) A, B, C, D
- 2) B, A, D, C
- 3) A, D, C, B
- 4) B, A, C, D

18. What is one common characteristic that eggs of different animals have?

- 1) They are laid on land.
- 2) They have soft shells.
- 3) They have hard shells.
- 4) They can develop into young animals.

19. Which one of the following shows the life cycle of a flowering plant correctly?

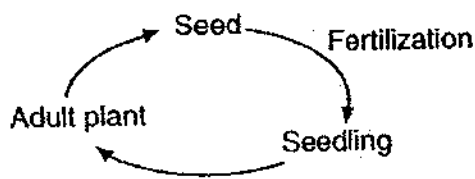

(1)

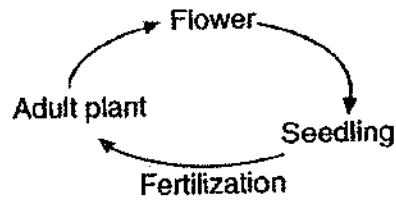

(2)

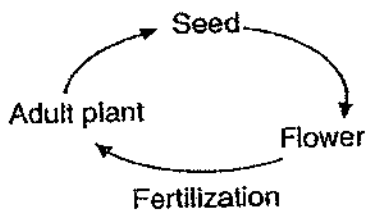

(3)

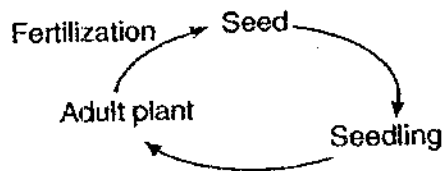

(4)

20. Which of the following plants produce seeds that will grow into young plants?

- 1) Moss
- 2) Algae
- 3) Angsana
- 4) Bird's nest fern

21. Mary wants to find out whether the germination of a seed is affected by light. Which of the following set-ups should she use?

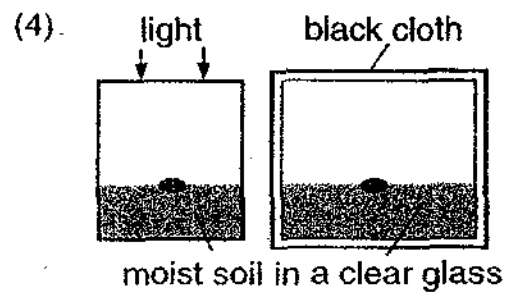
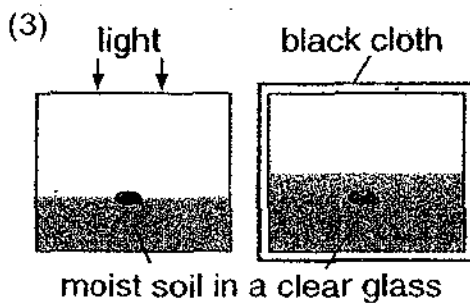
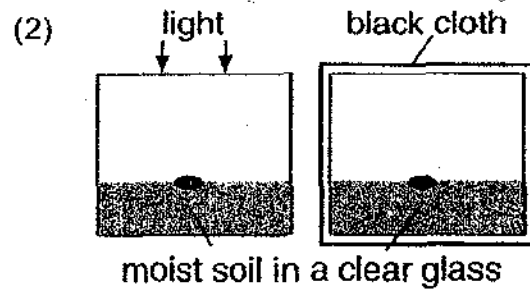
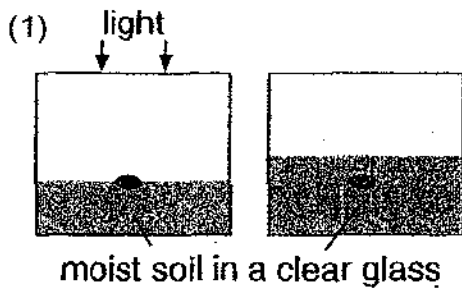

22. An unknown object, X, is dropped into a measuring cylinder filled with 50 ml of water. The water level rises to 70 ml.

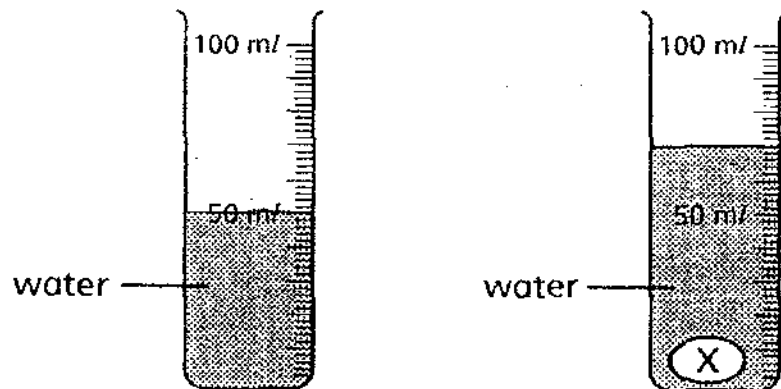

Based only on this observation, which of the conclusions can you make?

- A: X is flexible.
- B: X occupies space.
- C: X does not have a fixed mass.

- 1) A only
- 2) B only
- 3) A and B only
- 4) A and C only

23. A ball of plasticine is pressed under a heavy piece of wood.

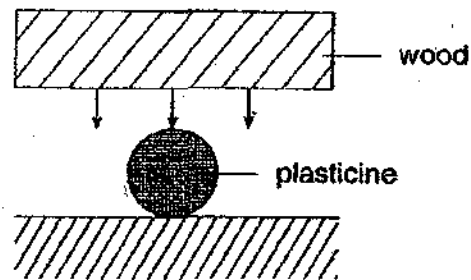

What change will the plasticine undergo?

- 1) Size
 - 2) Mass
 - 3) Shape
 - 4) Volume
24. Which of the following statements are true for all solids, liquids and gases?
- A: They have mass.
 - B: They occupy space.
 - C: They can be seen.
 - D: They have a definite shape.
- 1) A and B only
 - 2) C and D only
 - 3) A, B and C only
 - 4) A, B, C and D

25. The diagram below shows a jar containing 200 cm^3 of air and a pump containing 50 cm^3 of air.

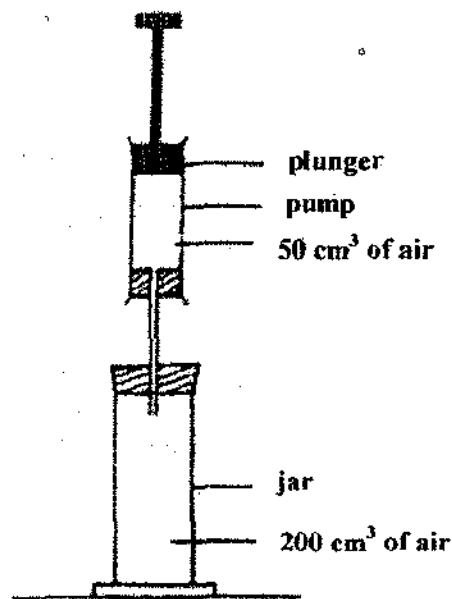

When the plunger is pushed all the way into the pump, all the air from the pump goes into the jar. What is the volume of air in the jar when the plunger is pushed down twice?

- 1) 100 cm^3
 - 2) 200 cm^3
 - 3) 250 cm^3
 - 4) 300 cm^3
26. The diagram below shows two flasks that are connected by a glass tube. There is a drop of ink in the tube.

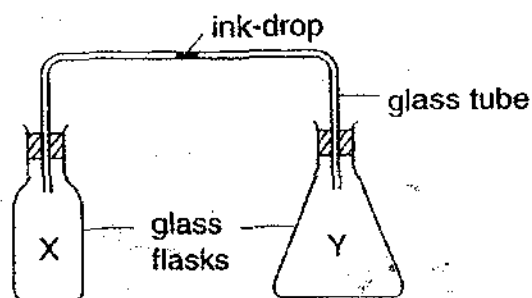

What should be done to the above set-up to move the ink-drop towards flask Y?

- 1) Put both flasks in cold water.
- 2) Put both flasks in very hot water.
- 3) Put flask X in cold water and flask Y in hot water.
- 4) Put flask X in hot water and flask Y in cold water.

27. A wooden block and a metal block balance each other on a clothes hanger as shown below.

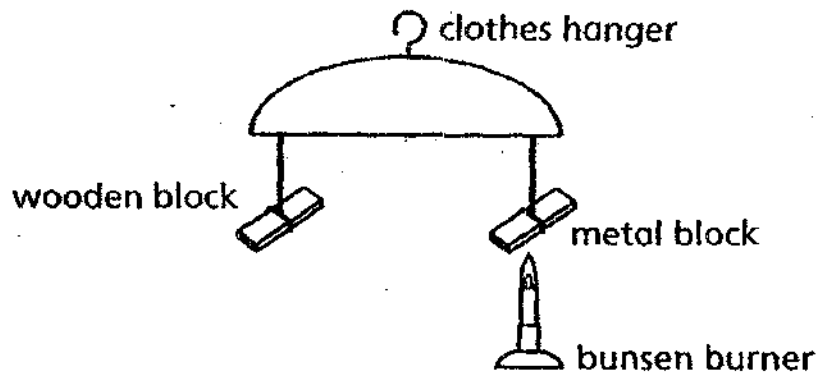

What will happen when the metal block is heated?

- A: The clothes hanger will tilt.
- B: The metal block will expand.
- C: The metal block will become warmer.

- 1) A only
- 2) B only
- 3) B and C only
- 4) A, B and C

28. Why will a tree die when a ring of bark is cut from its tree trunk?

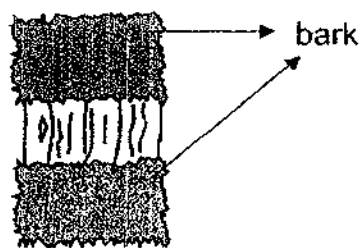

- 1) Food cannot be transported downwards to its roots.
- 2) Water cannot be transported downwards to its roots.
- 3) Oxygen cannot be transported upwards to its branches.
- 4) Carbon dioxide cannot be transported upwards to its branches.

29. A boy is dancing. He is swinging and bending his body parts.



Which two body systems work together to enable him to move his body parts?

A:

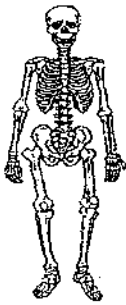

B:

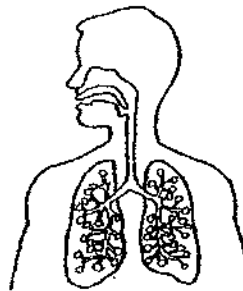

C:

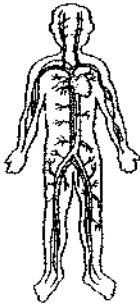

D:

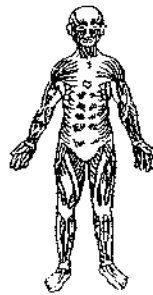

- 1) A and B
- 2) A and C
- 3) A and D
- 4) B and D

30. Alvin bought four souvenirs, A, B, C and D, from a tourist spot. When Alvin placed the souvenirs onto the refrigerator door which is made of metal, souvenirs B and C stuck to the door but souvenirs A and D dropped. When he placed an iron pin onto the door, the pin dropped too.

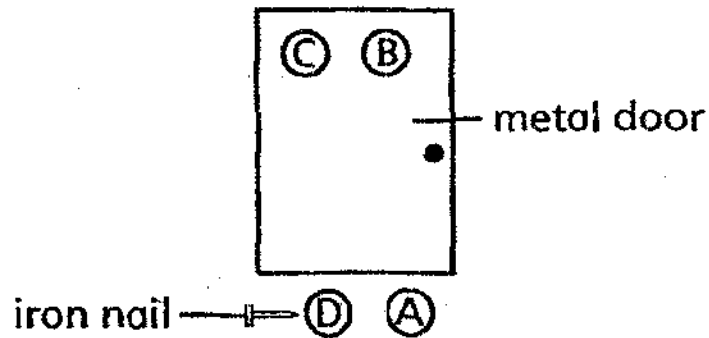

What can you conclude from the information given?

- A: Souvenirs A and D are made of non-magnetic materials.
- B: Souvenirs B and C are made of magnetic materials.
- C: The metal door is made of a magnetic material.
- D: There are magnets in souvenirs B and C.

- 1) A and B only
- 2) C and D only
- 3) A, C and D only
- 4) A, B, C and D



**NAN HUA PRIMARY SCHOOL
SEMESTRAL ASSESSMENT 2 – 2009
PRIMARY 4**

SCIENCE

BOOKLET B

14 Open-ended questions (40 marks)

Total Time for Booklets A and B : 1 hour 45 minutes

INSTRUCTIONS TO CANDIDATES

1. Write your name and index number in the space provided.
2. Do not turn over the page until you are told to do so.
3. Follow all instructions carefully.
4. Answer all questions.
5. Write your answers in this booklet.

Marks Obtained

Section B		/40
------------------	--	------------

Name: _____ () **Class:** P 4 _____

Date : 29 October 2009

Parent's Signature: _____

Section B: (40marks)

Write your answers to question 31 to 44.

The number of marks available is shown in brackets [] at the end of each question or part question.

31. Betty was walking along a corridor. When she turned at the end of the corridor, she bumped into Mr Kong.

(a) Draw on the diagram below to show **the positions of two mirrors** that could be used to enable Betty and Mr Kong to see each other. [1]

(b) Draw arrows to show the path of light that enables Betty to see Mr Kong. [2]

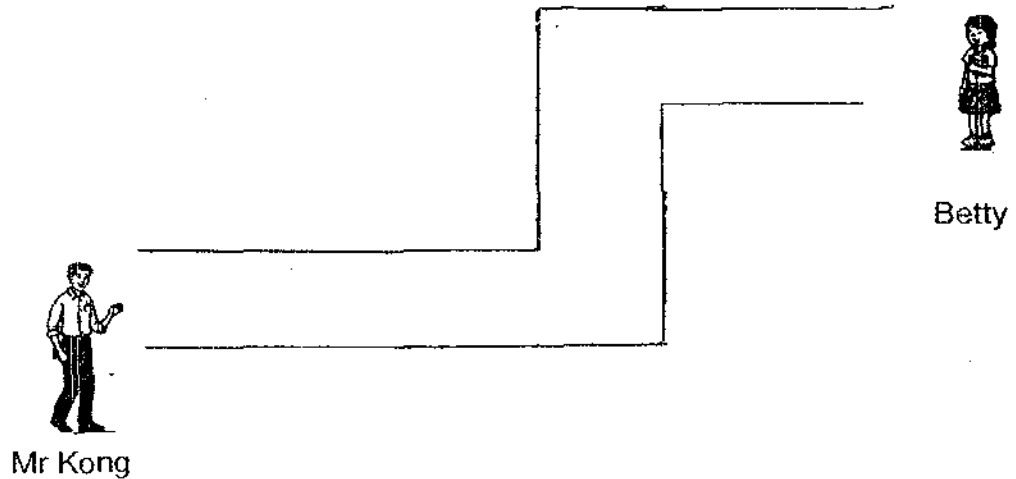

Score	
-------	---

32. A metal spoon is placed in a cup of hot Milo as shown in the diagram below.

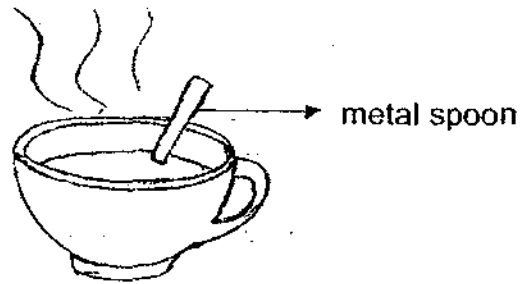

(a) Describe how the handle of the spoon feels like when you touch it. [1]

(b) Give a reason for your answer in (a). [1]

33. Classify the following in the table below. [3]

Moth Cockroach Grasshopper		Toad Duck Mosquito	
Young which look like their adults	Young which do not look like their adults		

Score	5
-------	---

34. There are four blocks of the same size. The diagram below shows the observation when the blocks are hung on a balance.

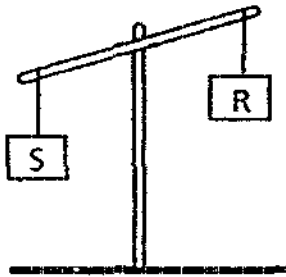
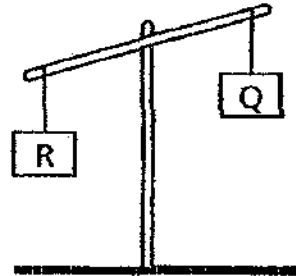
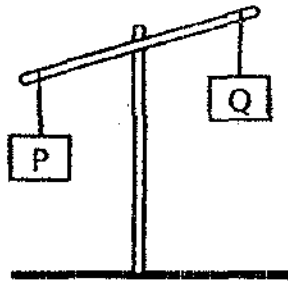

Based on the observation, which of the following conclusions is/are true, false or not possible to tell? Put a tick (\checkmark) in the appropriate box. [4]

	Statement	True	False	Not possible to tell
(a)	Block R has more matter in it than Block S			
(b)	Block Q is lighter than S			
(c)	Block Q is the lightest of all.			
(d)	Block P is made of a hard material.			

Score	4
-------	---

35. Haddy places some marbles into a cylinder filled with some water. The water level in the cylinder rises.

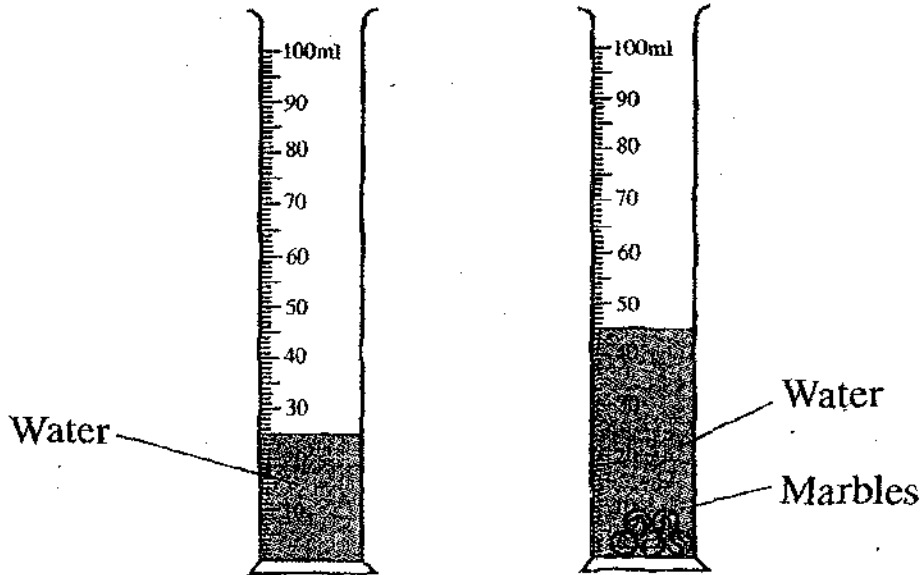

- (a) Give a reason for the increase in the water level. [1]

- (b) What is the volume of the marbles? [1]

- (c) When an identical marble is added to the measuring cylinder, what will be the new volume? [1]

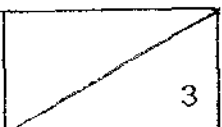
Score	
-------	---

36. Jane carried out the following experiment to investigate the transparency of clear glass and materials X, Y and Z to light.

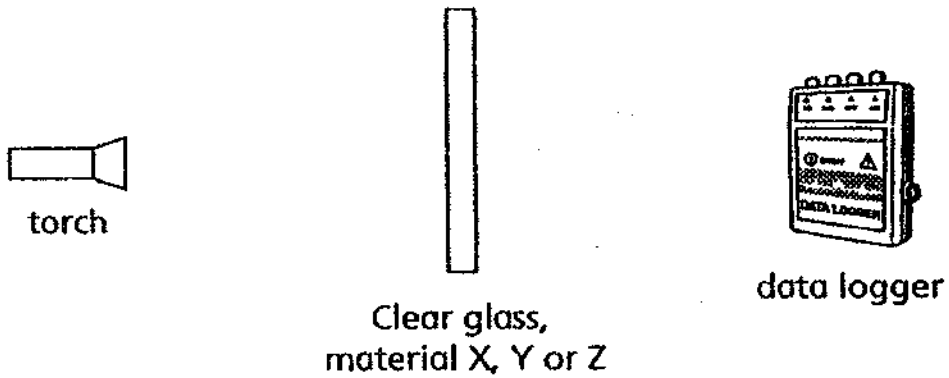

The bar graph below shows the result that Jane collected.

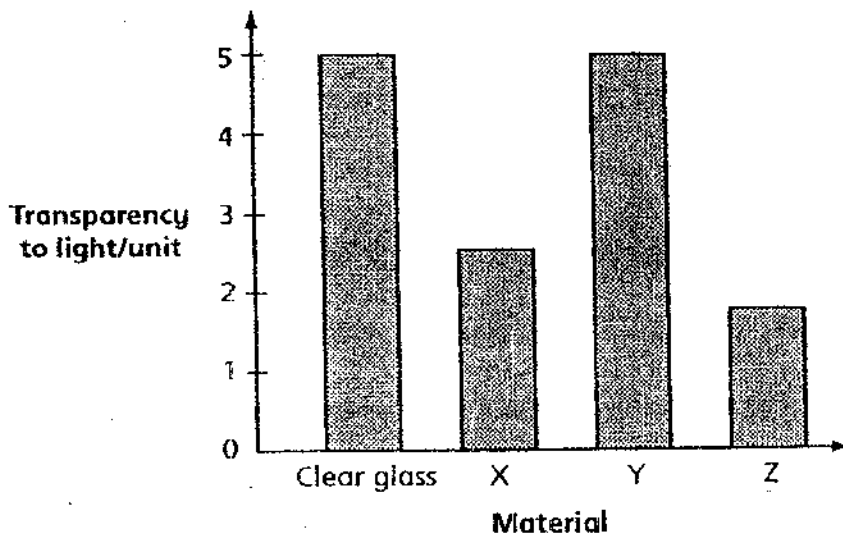

Based on the above results, write down the materials, X, Y and Z, in the classification table below. [3]

Group A	Group B	Group C
Rubber	Tap water	Frosted glass

Score	3
-------	---

37. Two metal strips can be joined together to form a bimetallic strip. The table below shows the observations made before and after three bimetallic strips were heated.

Before heating	After heating

Arrange the metals A, B, C and D in the correct order, beginning with the metal that expands the least when heated.

[2]

Score	2
-------	---

38. A group of Primary 4 pupils carried out an experiment, as shown below, to investigate whether dark coloured surfaces or light coloured surfaces absorbed more heat.

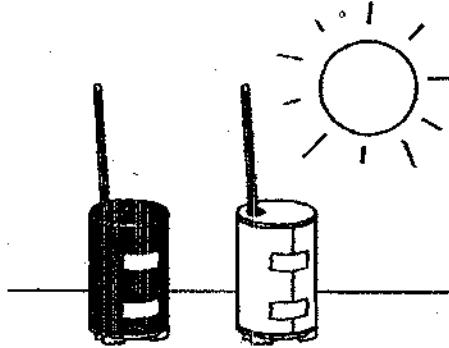

After 15 minutes, they recorded the temperature for both cans in the table below.

Time (min)	Temperature	
	Can that is wrapped in black paper	Can that is wrapped in white paper
0	32°C	32°C
15	38°C	33°C

- (a) Which colour shirt should the pupils choose to wear on a hot day? [1]

- (b) Give a reason for your answer in (a). [1]

- (c) Based on the results of the experiment, what is the relationship between the colour of the can and its temperature? [1]

Score	3
-------	---

39. Study the life cycle of a mosquito.

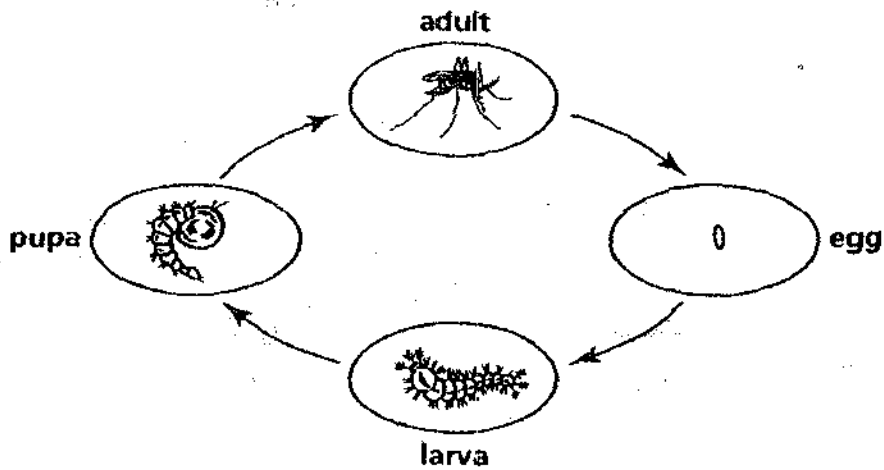

(a) At what stage is the wriggler at? [1]

(b) At what stage(s) of the life cycle does the mosquito stay in still water? [1]

(c) State one effective way in killing the life stage(s) of the mosquito mentioned in (b). [1]

Score	3
-------	---

40 Three seeds of the same kind are placed in beakers to grow.

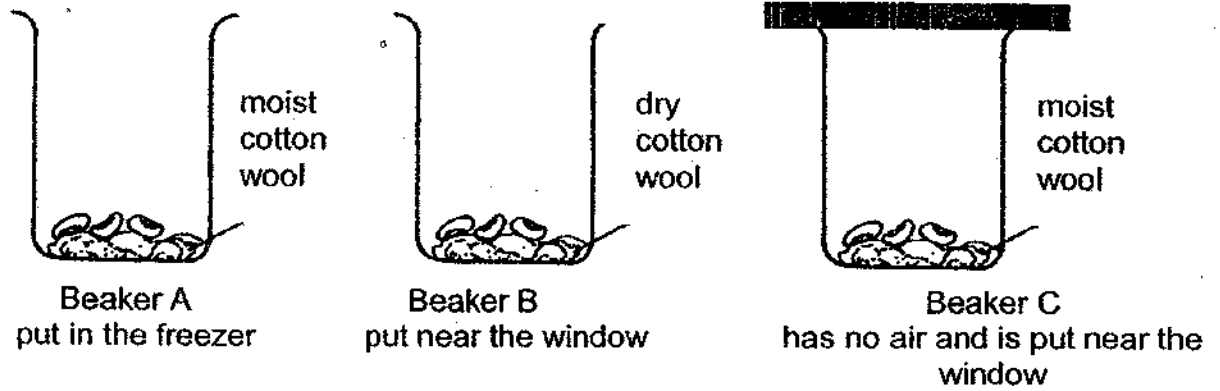

After one week, none of the seeds grew. State the condition needed for the seeds in Beaker A, B and C to grow respectively. [3]

Beaker A: _____

Beaker B: _____

Beaker C: _____

Score	3
-------	---

41 Jia Jun placed two different types of liquids, Liquid X and Liquid Y, in two bottles. After that, he placed the bottles in a basin of water at 100°C as shown in Diagram I. Diagram II shows the result after ten minutes.

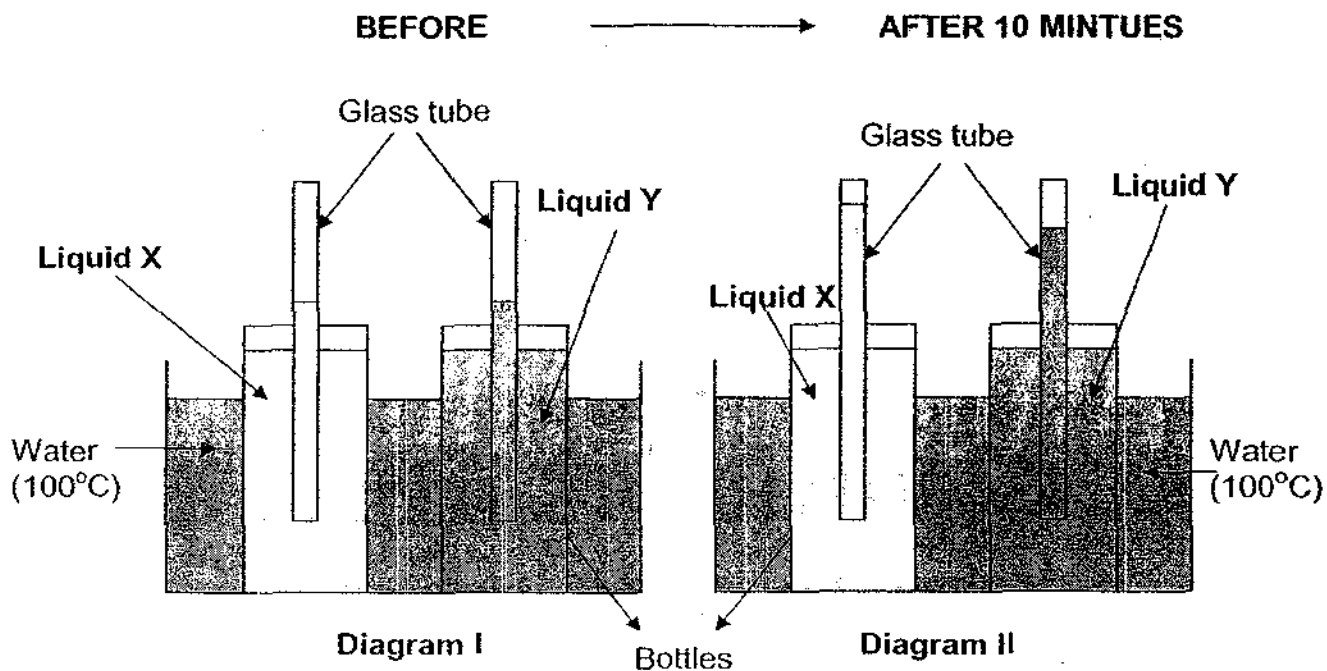

(a) Describe the change observed in the above set-up after 10 minutes. [1]

(b) Give a reason for your answer in (a). [2]

Score	3
-------	---

42. Timothy conducted an experiment on a green plant. He covered two leaves, both on the upper and lower surfaces of the leaves, with cardboards. He smeared another two leaves, again both on the upper and lower surfaces of the leaves, with a thick layer of oil. A week later, he observed that all the four leaves withered and died.

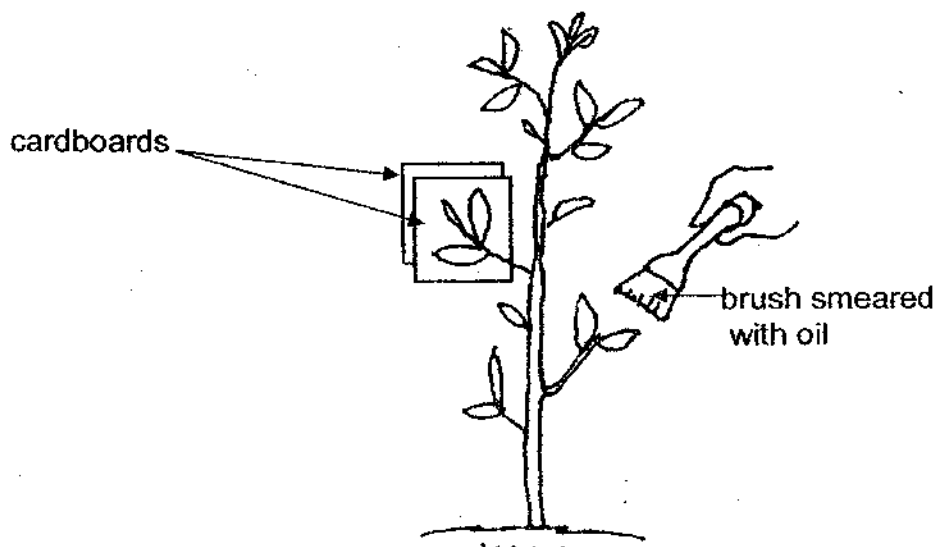

- (a) Explain why the four leaves withered and died. [2]

- (c) What does the experiment tell us about plants? [1]

Score	3
-------	---

43. The diagram below shows the human digestive system.

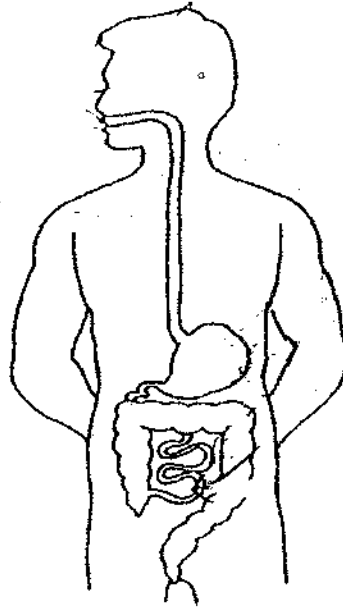

In the diagram above, label the parts in which digestive juices are added to the food so that digestion can take place. [2]

44. Some iron pins were dropped accidentally into a plastic container that contains detergent powder as shown below.

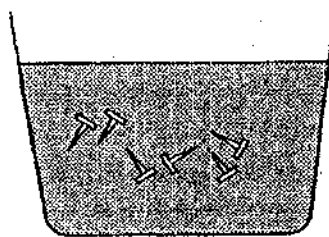

A magnet can be used to retrieve all the iron pins without touching the powder. Write down the steps to explain how it can be done. [3]

Score	5
-------	---

End of Paper

ANSWER SHEET

EXAM PAPER 2009

**SCHOOL : NAN HUA PRIMARY
SUBJECT : PRIMARY 4 SCIENCE**

TERM : SA2

Q1	Q2	Q3	Q4	Q5	Q6	Q7	Q8	Q9	Q10	Q11	Q12	Q13	Q14	Q15	Q16	Q17
4	1	2	4	4	2	1	2	1	2	3	3	1	4	2	4	3

Q18	Q19	Q20	Q21	Q22	Q23	Q24	Q25	Q26	Q27	Q28	Q29	Q30
4	4	3	2	2	3	1	2	4	4	1	3	2

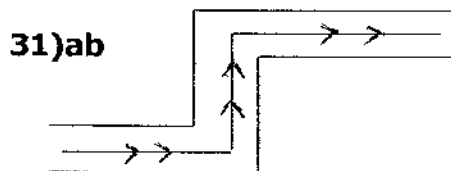

32)a)It feels very hot.

b)The heat from the hot Milo is transferred to the handle of the spoon and then to the hand.

33)Young which look like their adults

- 1)Cockroach
- 2)Grasshopper
- 3)Duck

Young which do not look like their adults

- 1)Moth
- 2)Toad
- 3)Mosquito

34)a)F b)T c)T d)Not

35)a)The marbles in the water occupies space.

b)The volume is 20cm³.

c)The new volume will be 40cm³

36)Group B: Y

Group C: Z, X

37)B,A,C,D

38)a)White shirt.

b)Based on the experiment, the can that is wrapped in white paper absorbed lesser light than the can that is wrapped in black,so, wearing white shirt makes the students cooler than wearing black shirt.

c)The lighter the colour the can, the cooler the temperature of the can.

39)a)It is at the larval stage.

b)The eggs, larva and the pupae of the mosquito stay in still water.

c)Spread a layer of oil on the surface of the water.

40)A: It needs warmth.

B: It needs water.

C: It needs air.

41)a)Liquid X's level increased more than Liquid Y's.

b)Both liquids expand when they gain heat from the hot water but liquid X expand more than liquid Y.

42)a)The cardboard blocked the sunlight from reaching the leaves cannot make food and die. The oil blocked the air from entering the stomata causing the leaves to die too.

b)Plants need air and light to survive.

43)

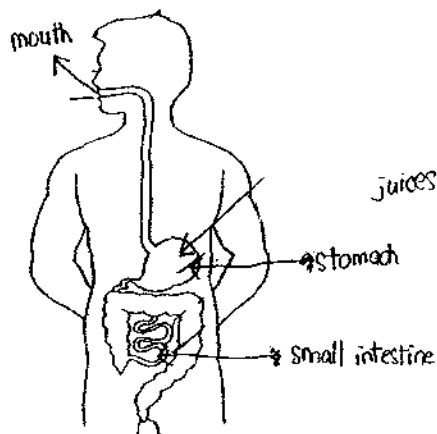

44)1)Put the magnet near the plastic container.

2)The pins will be attracted to the magnet.

3)Move the magnet upwards and the pins will also move.