



南洋小學

NANYANG PRIMARY SCHOOL

PRIMARY 4 SCIENCE

SEMESTRAL ASSESSMENT 2
2009

BOOKLET A

Date : 27 October 2009

Duration : 1 h 45 min

Name : _____ ()

Class: Primary _____ ()

**DO NOT OPEN THIS BOOKLET UNTIL YOU ARE TOLD TO DO SO.
FOLLOW ALL INSTRUCTIONS CAREFULLY.**

Booklet A consists of 15 printed pages including this cover page.

Section A (30 x 2 marks = 60 marks)

For each question from 1 to 40, four options are given. One of them is the correct answer. Make your choice (1, 2, 3 or 4). **Shade the correct oval (1, 2, 3 or 4) on the Optical Answer Sheet provided.**

1. Chris had two pots of seedlings, A and B, in his garden as shown in the diagram below. Both seedlings have been grown from seeds of the same plant for the same number of days. He had cut away the seed leaves of seedling A and the leaves of seedling B.

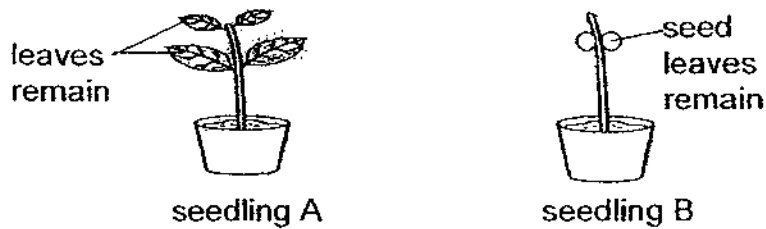

What would happen to the two seedlings after two weeks?

- (1) Both seedlings A and B would die.
 - (2) Seedling A would grow taller and seedling B would die.
 - (3) Seedling A would grow more leaves and seedling B would grow seed leaves.
 - (4) Seedling A would grow seed leaves and become taller while seedling B would die.
2. The diagram below shows the various stages in the life cycle of a toad.



Which one of the following shows the stages in its life cycle correctly?

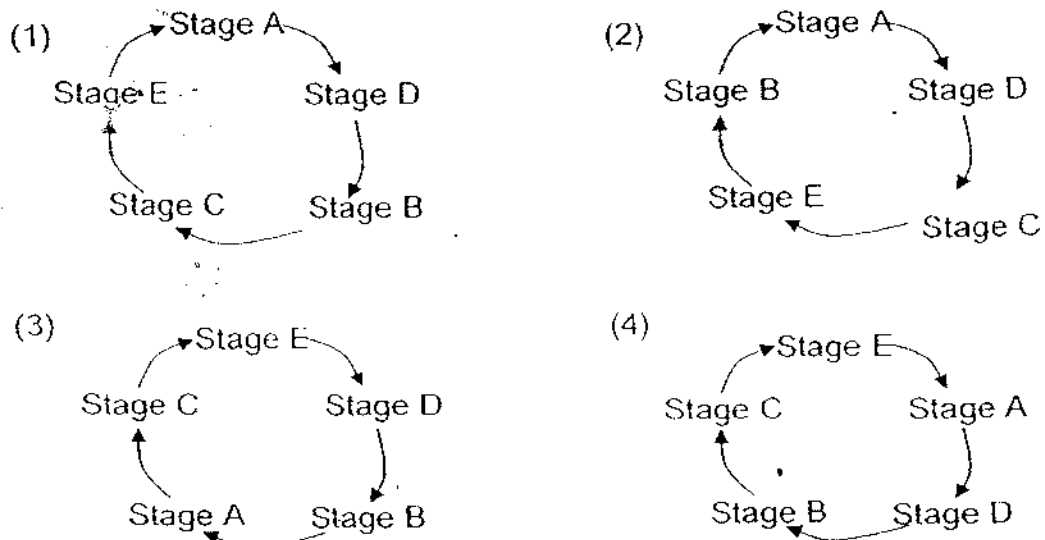

3. Study the life cycle of a termite as shown below.

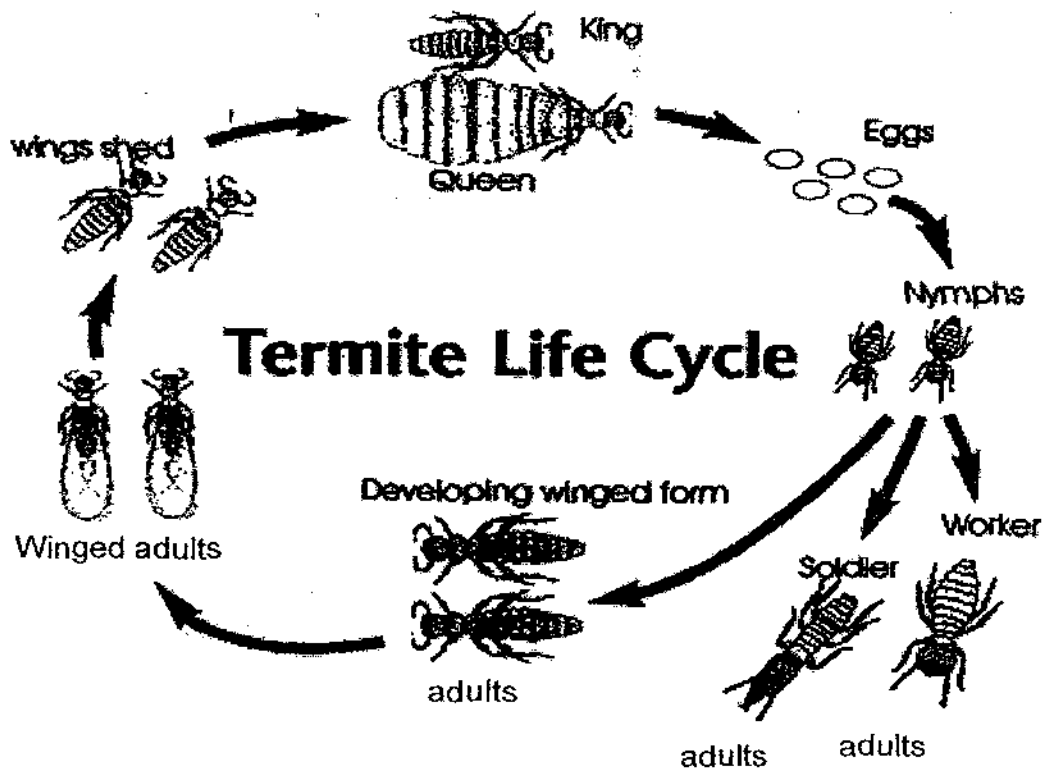

Which one of the statements below is **false** about the life cycle of the termite?

- (1) The young of a termite looks like its adult.
 - (2) There are 6 stages in the lifecycle of a termite.
 - (3) The termites go through moulting process at the nymph stage.
 - (4) Both the female and male termites ~~are~~ are needed for reproduction.
4. Malek described a body organ to James. He said, " It has strong muscular walls. The muscles contract and relax to push the food down. However, no digestive juice is produced here."

Which organ was Malek describing?

- | | |
|-------------|------------|
| (1) Mouth | (2) Gullet |
| (3) Stomach | (4) Rectum |

5. The diagram below shows the digestive system in a human body.

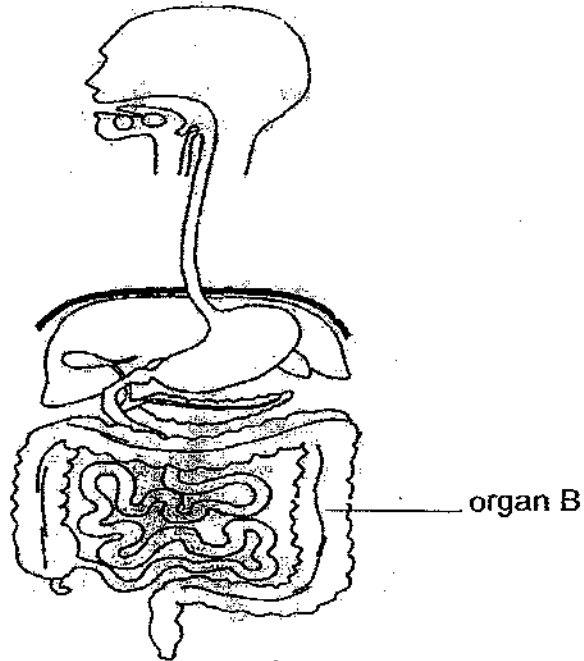

Which one of the following statements describes what happens in organ B during digestion?

- (1) Digestion is completed here.
 - (2) Water is removed from the undigested food.
 - (3) The digested food is passed out to the rectum.
 - (4) Digestive juice is added to break down the food.
6. Which of the following statements about matter are true?

- A Matter has mass.
 - B Matter occupies space.
 - C Matter can always be seen.
 - D Matter consists of living and non-living things.
- (1) A and C only
 - (2) A, B and D only
 - (3) B, C and D only
 - (4) A, B, C and D

~~Object~~ A, B, C and D have been classified in the flowchart below based on their properties. Refer to the flowchart below to answer questions 7 and 8.

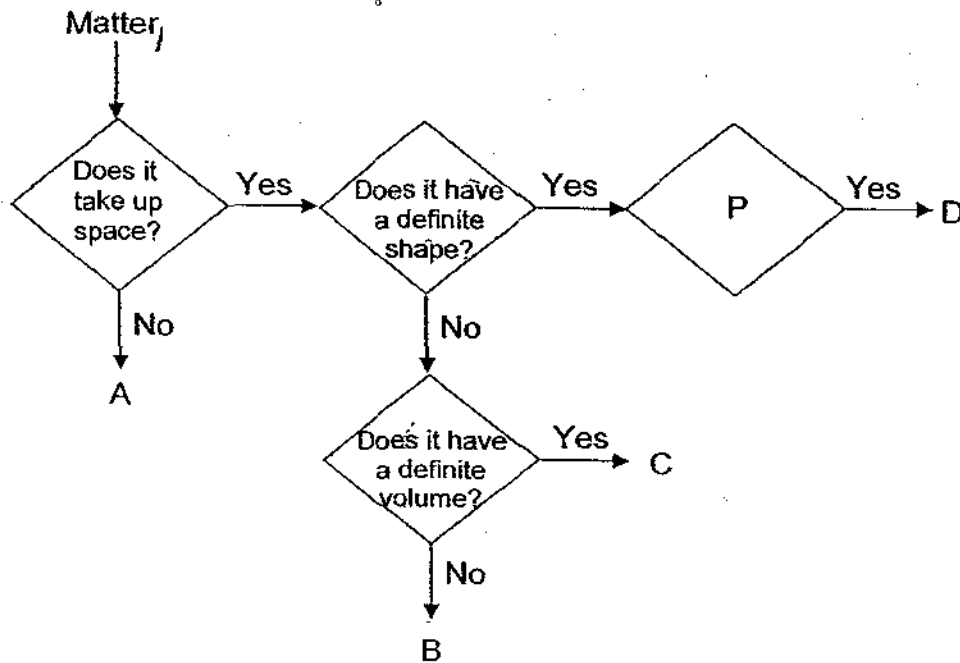

7. Which one of the following questions should be placed in box P?

- (1) Is it a liquid?
- (2) Is it a matter?
- (3) Can it be compressed?
- (4) Does it have a definite volume?

8. Which one of the following could correctly represent A, B, C and D?

	A	B	C	D
(1)	shadow	oxygen	coffee	rock
(2)	syrup	shadow	carbon dioxide	apple
(3)	shadow	ice	pear	milk
(4)	nitrogen	water vapour	shadow	dice

11. Which of the following objects has no definite shape?

- A Oil
- B Spoon
- C Oxygen
- D Feather

- (1) A and B only
- (2) A and C only
- (3) B and C only
- (4) B and D only

12. Joel bought Peter a gift. He did not want Peter to know what the gift was until it has been unwrapped. Which one of the following materials should he use to wrap his gift?

- (1) tracing paper
- (2) cellophane paper
- (3) clear plastic sheet
- (4) coloured construction paper

13. Study the opaque object shown below.

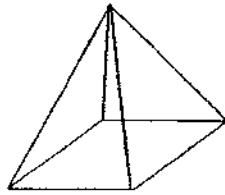

A torchlight was used to form shadows of the above object on a wall. If the position of the torchlight could be changed with respect to the object, which of the following shadows could be formed by the object above?

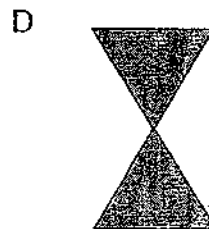
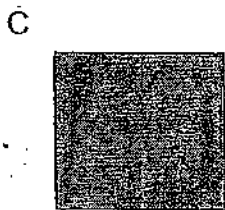
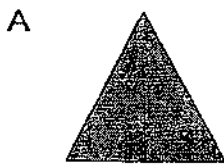

- (1) A and B only
- (2) A and C only
- (3) A, B and C only
- (4) A, B and D only

14. Which one of the following statements about shadows is false?

- (1) Shadows do not take up space.
- (2) When light is blocked, shadows are formed.
- (3) The shape and size of shadows can be changed.
- (4) Shadows can only be formed when there is sunlight.

15. Marc shines a torch on a rod and measured the height of its shadow which was formed on a wall. He then moved the torch away from the rod and measured the height of the shadow again. He repeated his experiment with different distances between the torch and the rod. He recorded his results as shown below.

Distance between torch and rod (cm)	Height of shadow (cm)
3	8
5	6
7	4
9	2

Which one of the following conclusions could he make from the results obtained?

- (1) When the distance between the torch and rod increases, the rod becomes smaller.
- (2) When the distance between the torch and rod increases, the rod becomes bigger.
- (3) The shorter the distance between the torch and the wall, the ~~longer~~ the ~~length~~ of its shadow.
- (4) The shorter the distance between the torch and the rod, the darker the shadow.

16. Study the photograph of the golf ball below. A, B, C and D are directions which a light source may be shone from.

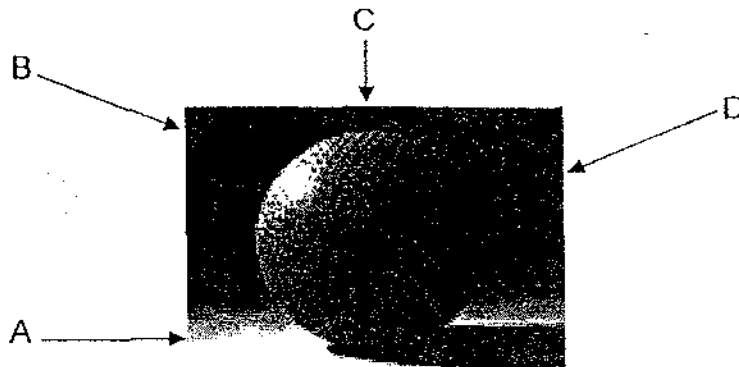

From which direction is the light source coming from?

- (1) A
- (2) B
- (3) C
- (4) D

17. Grace conducted an experiment using a datalogger. She tested the light sensor at different locations in the school at noon. She recorded her results in the table below.

Locations in school	Light intensity (lux)
School field	5000
Q	250
Canteen	1300

- Which one of the following locations could Q be?
- (1) Courtyard
 - (2) Science garden
 - (3) Basketball court
 - (4) Covered carpark
18. Which one of the following pairs could not be sources of light?
- (1) flame and stars
 - (2) moon and mirror
 - (3) bulb and television
 - (4) handphone and lamp
19. When placed in a bright room, which of these objects can reflect light into our eyes?
- A Mirror
 - B Glass mug
 - C Tennis ball
 - D Wooden table
- (1) A only
 - (2) A and B only
 - (3) A, B and D only
 - (4) A, B, C and D
20. Which one of the following statements about energy is false?
- (1) Light is a form of energy.
 - (2) Light energy allows us to see.
 - (3) Light energy has shape and occupies space.
 - (4) Light energy can be reflected by an object into our eyes.

21. Which of the following statements are true about heat?

- A Heat is a matter.
- B Heat is a form of energy.
- C Heat is produced when a firefly emits light.
- D Heat is produced when a battery-operated toy is switched on.

- (1) B only
- (2) A and B only
- (3) A, C and D only
- (4) B, C and D only

22. Which of the following pair of electrical appliances produces heat that is unwanted?

- (1) An oven and a lamp
- (2) A radio and a computer
- (3) A steam iron and a freezer
- (4) A toaster and a rice cooker

23. The diagram below shows a glass of lime juice.

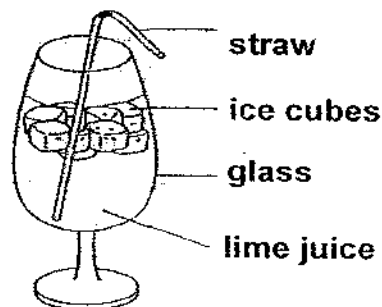

The ice cubes were added to the lime juice. After one minute, which one of the following options correctly shows whether heat is gained or lost by lime juice, ice cubes and glass?

	Lime juice	Ice cubes	Glass
(1)	Gains heat	Loses heat	Gains heat
(2)	Gains heat	Gains heat	Loses heat
(3)	Loses heat	Loses heat	Loses heat
(4)	Loses heat	Gains heat	Loses heat

24. Three pieces of wax, P, Q and R, were attached on a circular metal ring as shown below. A, B, C and D were locations on the metal ring.

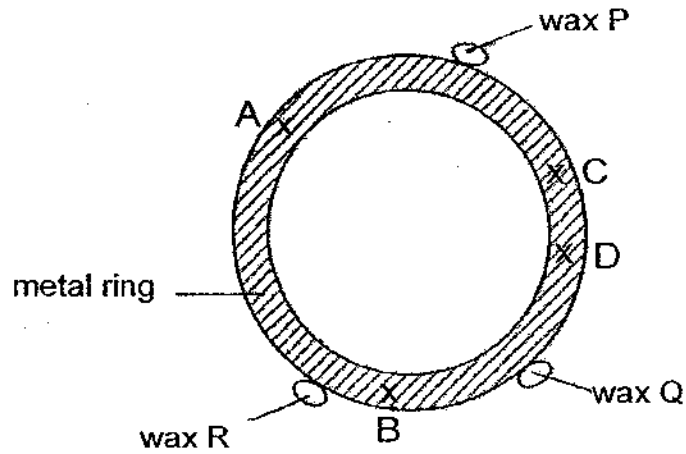

When Wei Wei heated the ring at a particular location, the wax melted in the following order: P, Q and R.

At which spot, A, B, C or D, did Wei Wei heat the ring?

- | | |
|-------|-------|
| (1) A | (2) B |
| (3) C | (4) D |

25. Roy did an experiment on heat as shown below.

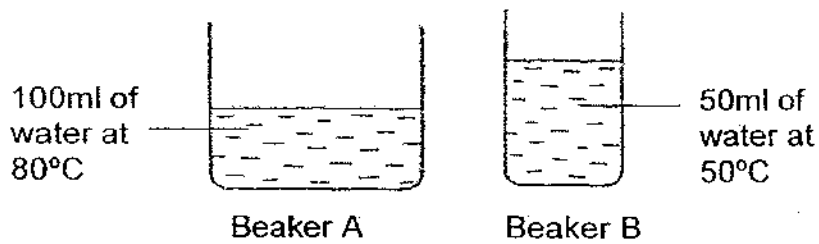

He poured all the water from beaker B into beaker A. What would the temperature of the water in beaker A be now?

- | | |
|-----------|------------|
| (1) 50 °C | (2) 65 °C |
| (3) 80 °C | (4) 130 °C |

26. Serene took two ice cubes, A and B, which weighed 100 grams each, from the freezer. She covered ice cube B with sawdust.

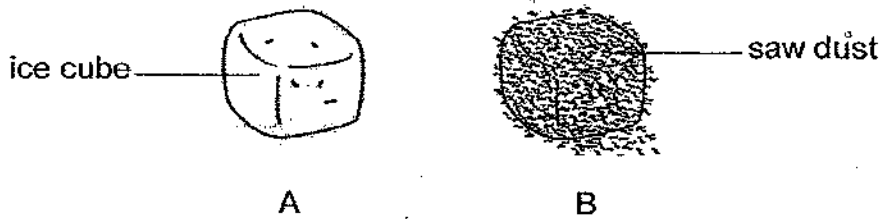

After one minute, she observed that the size of ice cube A is smaller than ice cube B. Which one of the following statements about the experiment is **false**?

- (1) Saw dust is a poor conductor of heat.
 - (2) Ice cube A acts as a control in the experiment.
 - (3) The surrounding air is warmer than the ice cubes.
 - (4) Ice cube A is gaining heat while ice cube B is losing heat.
27. Zul wrapped a piece of paper over a rod. Half of the rod was made of copper while the other half of the rod was made of wood. The flame was placed near the paper but not touching it.

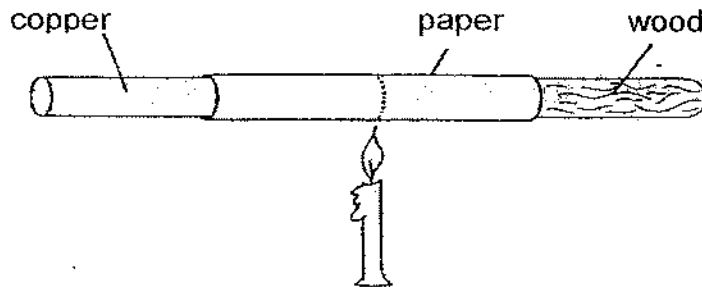

Which one of the following observations would be made by Zul after three minutes?

- (1) The whole paper would be burnt.
- (2) The whole paper would remain unburnt.
- (3) The part of the paper around the wood would be burnt but the part around the copper would remain unburnt.
- (4) The part of the paper around the wood would remain unburnt while the part around the copper would be burnt.

28. Aunt Mary brewed a pot of hot tea. She poured the tea into 3 cups at the same time. The cups were made of different materials, Q, P and R. The time taken for the tea in each cup to cool down was recorded and a graph was plotted as shown below.

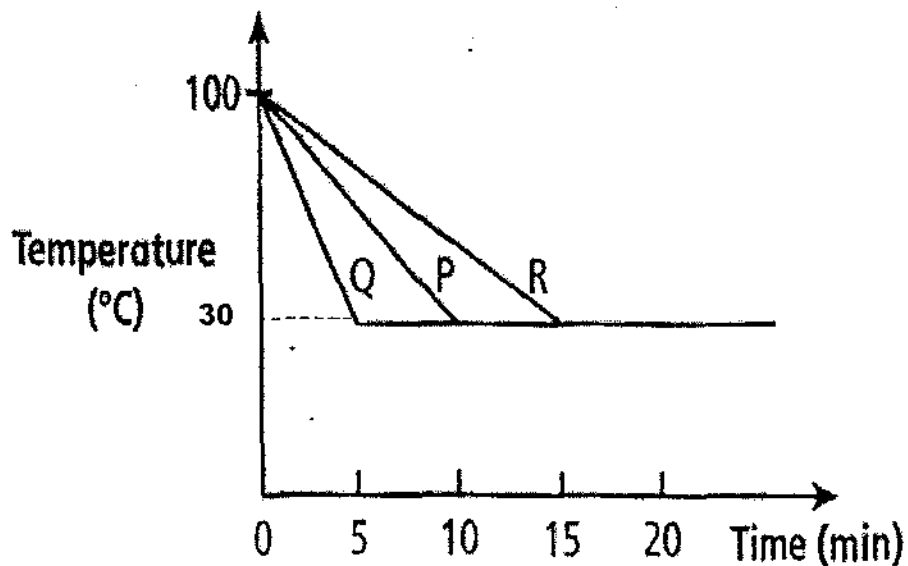

Based on the graph, which one of the following statements is true?

- (1) Q is a better conductor of heat than P.
- (2) P is a poorer conductor of heat than R.
- (3) R conducts heat best after 15 minutes.
- (4) Q conducts heat as fast as P after 5 minutes.

30. Guo Wei placed a test tube of cold water into a beaker of crushed ice which had some salt added to it. After an hour, he found that the water in the test tube had frozen.

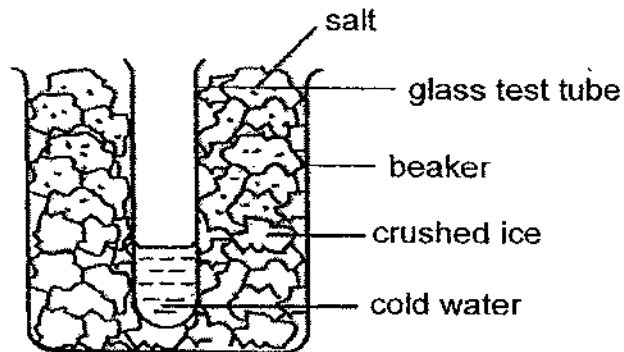

Which of the following statements is **false** about the experiment?

- (1) The cold water loses heat to the crushed ice.
- (2) Heat travels from the beaker to the crushed ice.
- (3) The glass test tube is a good conductor of heat.
- (4) The temperature of the crushed ice is lower than the cold water.



南洋小學

NANYANG PRIMARY SCHOOL

PRIMARY FOUR SCIENCE
SEMESTRAL ASSESSMENT 2

2009

BOOKLET B

Date : 27 October 2009

Duration : 1 h 45 min

Name : _____ ()

Class: Primary _____ ()

Marks Scored:

Booklet A:		60
Booklet B :		40
Total :		100

Parent's signature:

**DO NOT OPEN THIS BOOKLET UNTIL YOU ARE TOLD TO DO SO.
FOLLOW ALL INSTRUCTIONS CAREFULLY.**

Booklet B consists of 14 printed pages including this cover page.

Section B (40 marks)

Write your answers to questions 31 to 46 in the spaces provided.
Marks will be deducted for misspelt key words.

31. The diagrams below show the life cycle of a ladybird and a housefly.

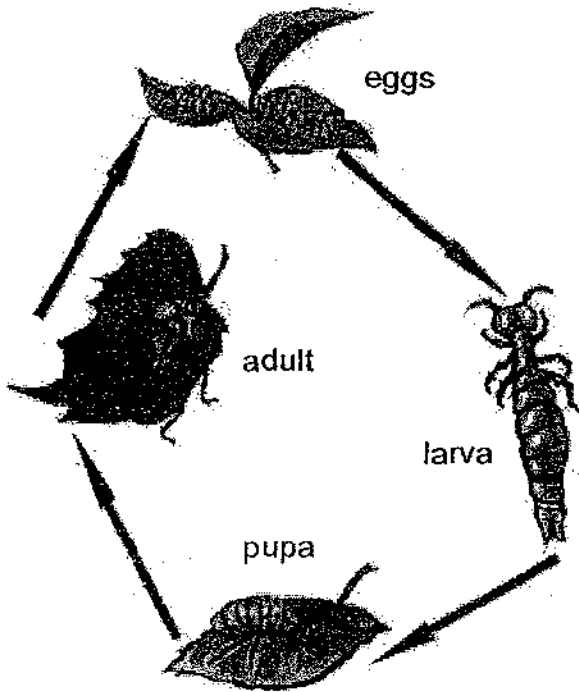

Life cycle of a ladybird

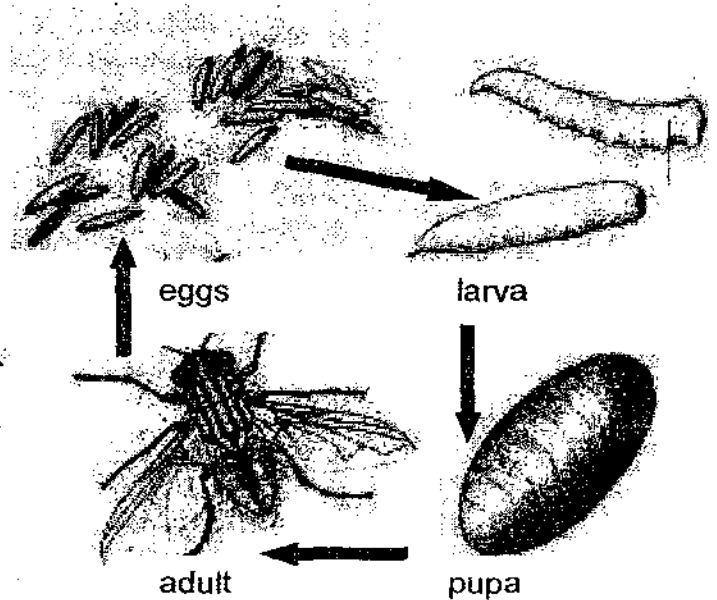

Life cycle of a housefly

(a) Which stage of the life cycle of both insects is harmful to Man? [2]
The _____ stage of the ladybird is harmful to Man.

The _____ stage of the housefly is harmful to Man.

(b) Name another organism that has a life cycle with the same number of stages as the housefly and ladybird. [1]

32. (a) State the function of teeth in ^{the} digestive system. [1]

(b) Damai did an experiment on digestion. She bought a piece of meat and cut it into two equal parts, A and B. The table below recorded what she did to the meat and the time taken for the meat to digest after she added an equal amount of digestive juice to each meat.

	Part A	Part B
Treatment	Cut into smaller pieces	Not cut into smaller pieces
Amount of digestive juice added (ml)	100	100
Time taken for the meat to be completely digested (hours)	5	10

Explain why part B took a longer time for the meat to be fully digested. [2]

33. Study the classification chart below carefully.

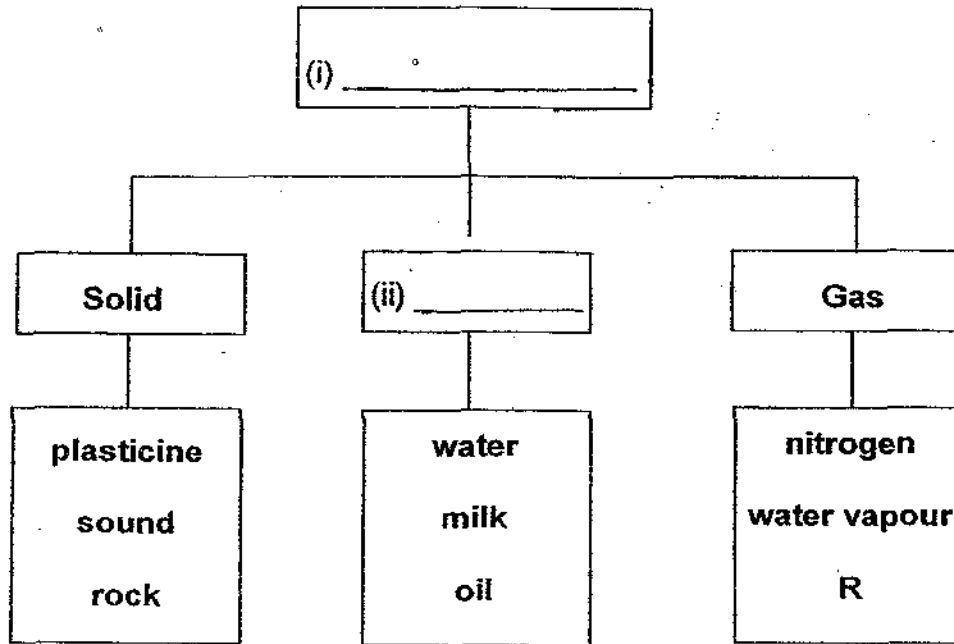

(a) Fill in (i) and (ii) in the chart above with the correct headings. (1)

(b) What could R represent in the above chart? (1)

(c) One of the examples given above was classified wrongly. Identify this example and explain why it was classified wrongly. (1)

34. Kimberley poured some coloured water into the container below. Jars A, B, C and D were all connected at the base, where water could flow through freely.

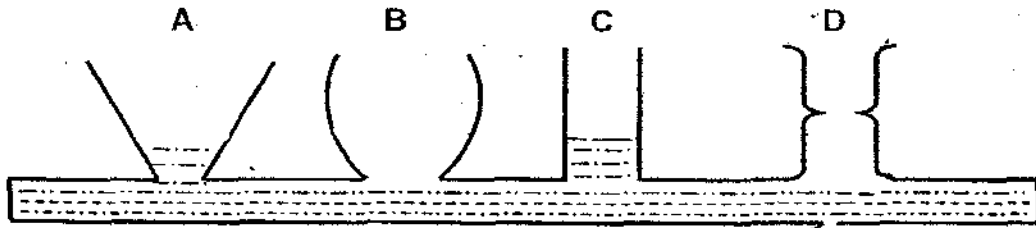

- (a) Help Kimberley to complete her work by **drawing straight lines in Jars B and D** to indicate the correct water levels. [1]
- (b) Which property of liquids is demonstrated in the activity above? [1]

35. Chester used some old cardboards and 2 mirrors to make a toy periscope as shown in the diagram below.

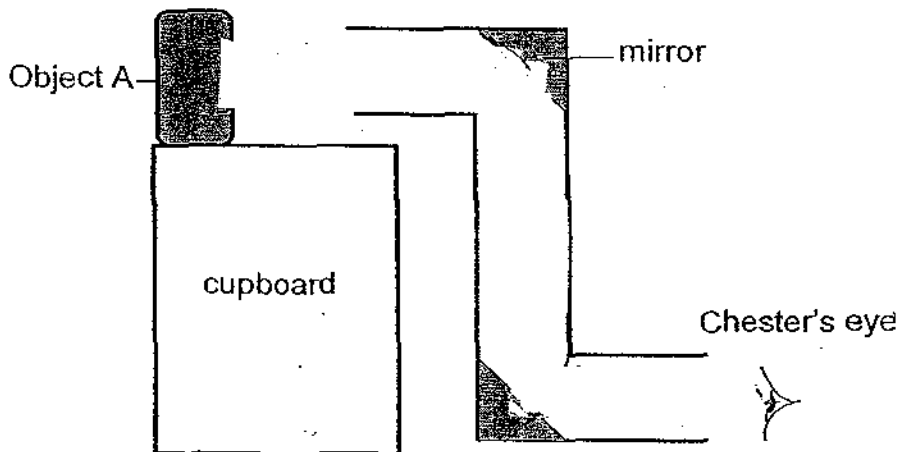

- (a) **Draw straight lines with arrows** in the diagram above to show the path of light rays from object A to Chester's eyes. [1]
- (b) State the 2 properties of light that enable him to use the periscope to see the object. [2]

(i) _____

(ii) _____

36. Study the examples given below and classify them in the classification table. Each example is to be classified once only. [3]

lamp	lightning	moon
candle	gold ring	fireworks

Light sources	Non-light sources

37. Nicholas cut out a star from a piece of cardboard. He then used the cardboard to cast a shadow on his bedroom wall using a torchlight as shown below.

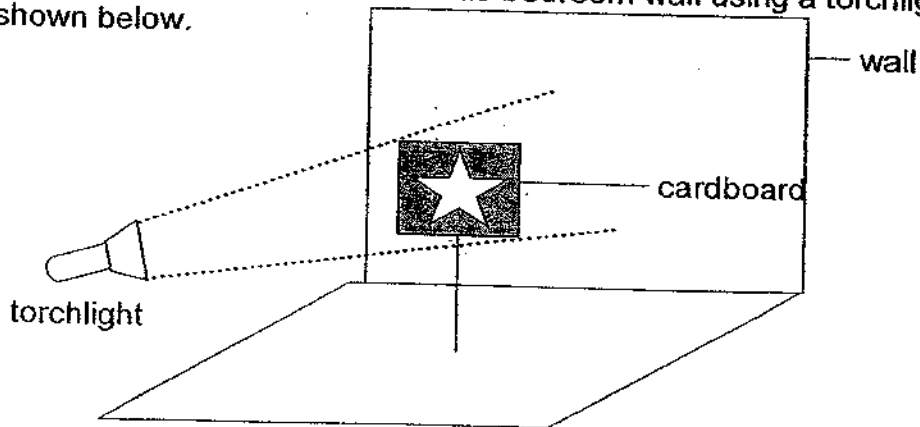

- (a) In the diagram below, shade the shadow that would be formed on his wall. [1]

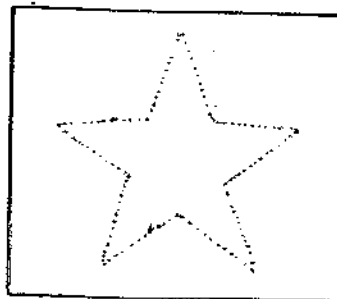

- (b) Without changing the cardboard, state one change that could be made in order for him to make a bigger shadow. [1]

38. Yi Xuan carried out an experiment using 3 sheets, R, S and T, to determine their degree of transparency to light. He conducted his experiment using a datalogger as follows:-

- Place a torchlight directly in front of the light sensor of a datalogger.
- Record the reading.
- Place sheet R between the torchlight and the light sensor.
- Record the reading.
- Repeat the experiment with sheets S and T respectively.

His results were recorded as follows.

Sheets	1 st reading (lux)	2 nd reading (lux)	3 rd reading (lux)
None	5000	5000	5000
R	1400	1390	1410
S	0	0	0
T	4800	4950	4890

(a) Based on the results above, state the properties of sheets R, S and T as demonstrated in this experiment. [1]

R: _____

S: _____

T: _____

(b) Explain why Yi Xuan conducted the experiment with no sheet used at first. [1]

39. Vera conducted an experiment to find out how the time of the day affects the ~~length~~ of the shadow of a 10 cm stick as shown in the diagram below.

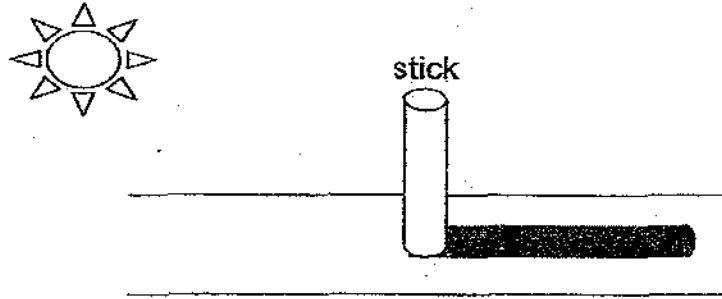

She then drew the graph below based on the results she had obtained.

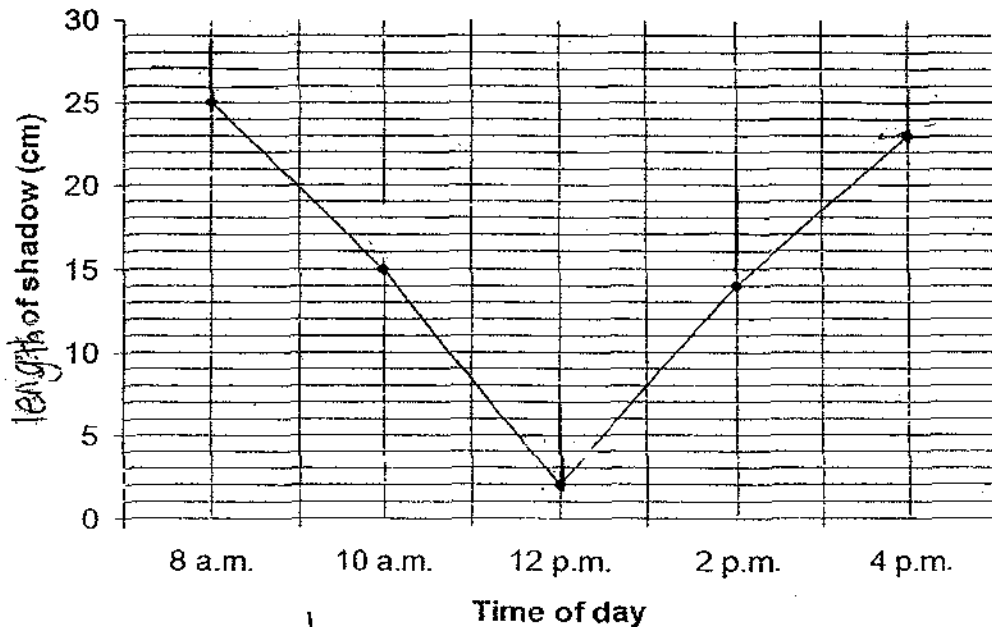

- (a) What was the ~~length~~ of the shadow at 10 a.m.? (1/2)
_____ cm.

- (b) Why was the shadow of the stick shorter than the length of the stick at 12 p.m.? (1/2)

- (c) Based on her results, how does the time of the day affect the ~~length~~ of the shadow before 12 p.m.? (1)

40. Megan was given a candle and a few cardboards of equal size to conduct an experiment on light. She made holes in the middle of each cardboard and placed them in a row. She then placed the lighted candle in front of the first cardboard. When she looked through the hole of the cardboard E, she could see the candle as shown in the diagram below.

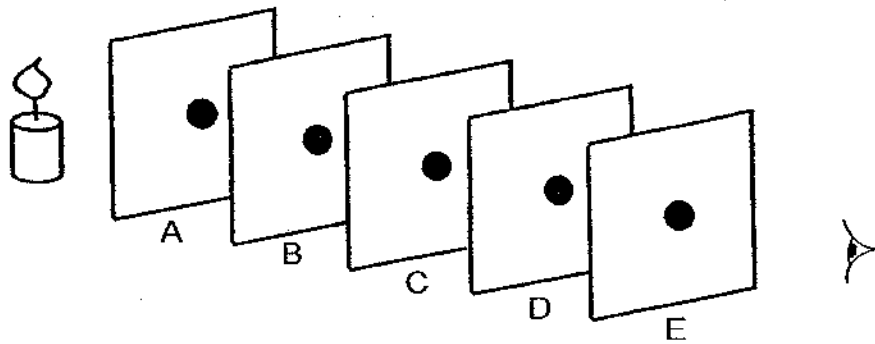

- (a) Which property of light allows her to see the candle? [1]

- (b)(i) She then changed cardboard C to a clear plastic sheet without a hole in the middle. Would she be able to see the candle now? [1]

- (ii) Explain your answer in (i) [1]

- (c) What would she observe if she moved cardboard B so that the hole is no longer in line with the rest of the cardboards? [1]

41. Susanna placed two thermometers on an open ground. She covered one of them with a black cloth and the other with a white cloth. She then left them on the ground for thirty minutes.

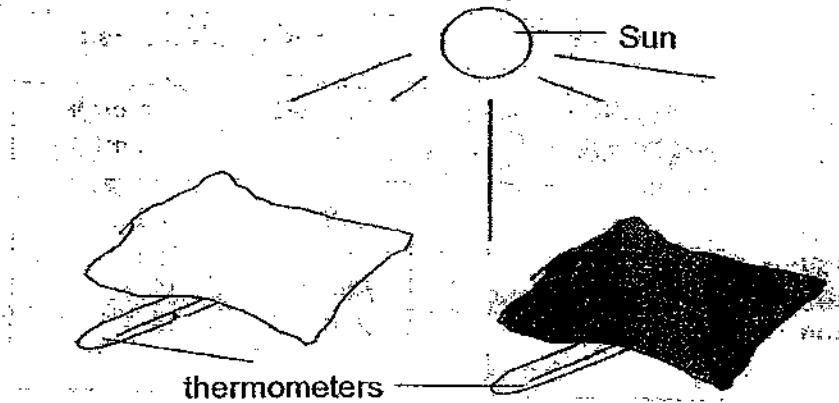

She recorded the results of her findings as shown below:

Cloth	Temperature at the start	Temperature after 30 minutes
White cloth	31°C	34°C
Black cloth	31°C	38°C

- (a) What conclusion could Susanna make from this experiment? *11*

- (b) Based on this experiment, what colour shirt should Susanna wear when she goes out on a sunny day? *U*

42. Mr Lee conducted an experiment to study the effect of outer covering on heat loss. He placed the 2 beakers, A and B, in the same room at a temperature of 18°C.

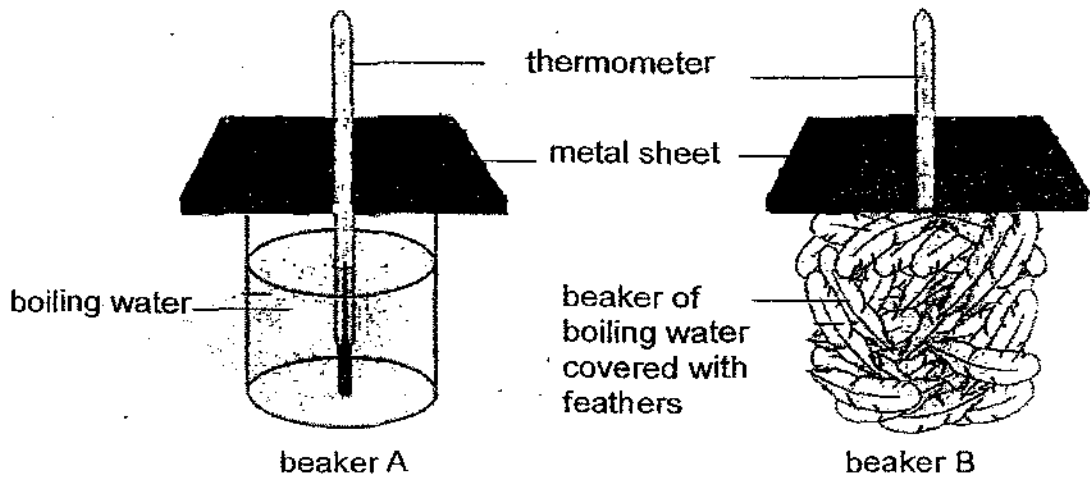

- (a) After 30 minutes, which beaker would have a higher temperature than the other? [1/2]

- (b) Explain your answer in (a). [1 1/2]

43. The diagram below shows 2 empty glass bottles connected by a glass tube. There is a drop of ink in the tube.

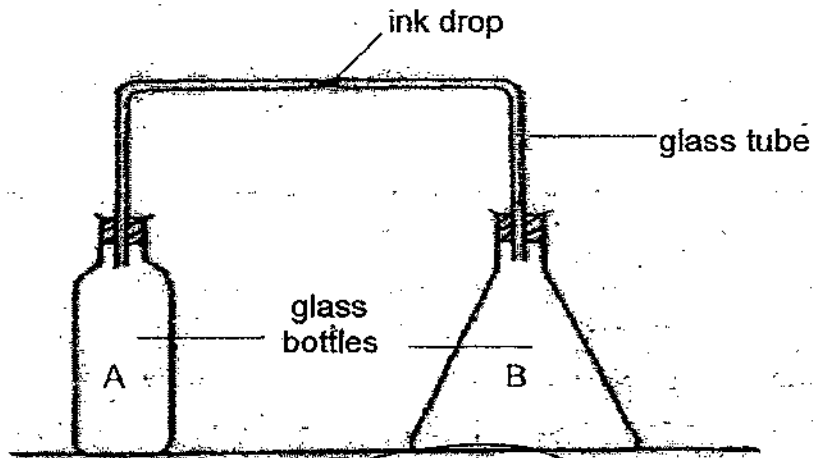

- (a) Given a basin of hot water, without disconnecting or breaking the apparatus, suggest a way to cause the ink drop to move nearer to bottle A. [1]

- (b) Explain how your method enables the ink to move towards A. [1]

44. Matter expands when heated. The diagram below shows a strip that is made up of Metal X and Metal Y. When heated, the piece of metal would curve.

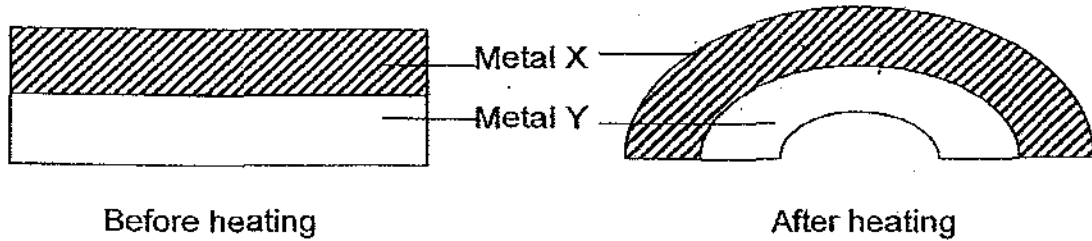

Explain why the strip curved when heated. [1]

45. Jean had difficulty opening a tightly screwed glass jar of strawberry jam which had a steel lid. Her father suggested pouring hot water onto the steel lid.



Explain how her father's method would enable the lid to be removed more easily. [2]

46. Ivan took a glass bottle A and covered it with a deflated balloon as shown in the diagram below. He did the same to glass bottles B and C.

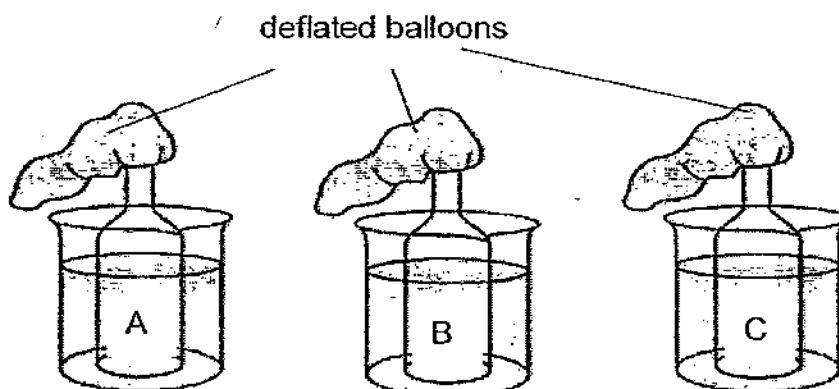

He then immersed each glass bottle into each beaker of water that is of different temperatures as shown in the table below. After two minutes, he observed that the balloons were of different sizes. He measured the length PQ for each balloon and recorded it on a table.

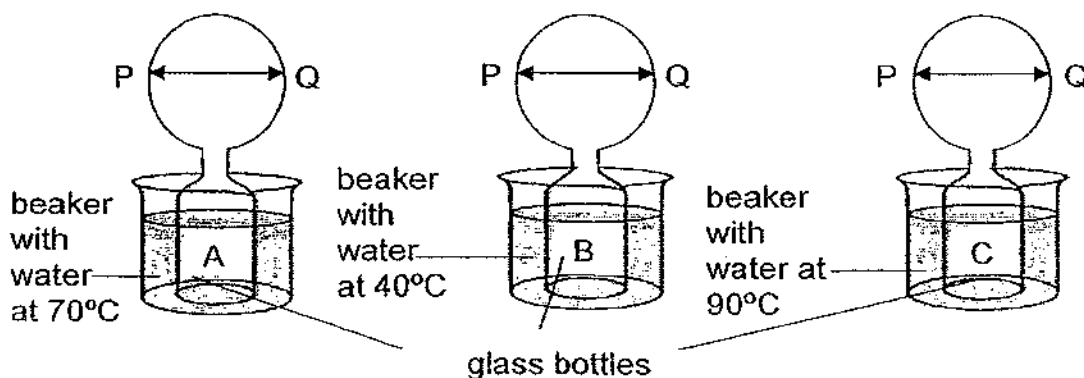

- (a) Based on the above experiment, complete the table below by matching the glass bottles, A, B and C, to the size of the balloons. [3]

Length of PQ	Glass bottle
8cm	
15cm	
20cm	

- (b) Explain what happens if metal bottles are used instead of glass bottles.

-----END OF PAPER-----

Setters: Ms Alice Chong
Ms Yasmeen Mohamad

ANSWER SHEET

EXAM PAPER 2009

**SCHOOL : NANYANG PRIMARY
SUBJECT : PRIMARY 4 SCIENCE**

TERM : SA2

Q1	Q2	Q3	Q4	Q5	Q6	Q7	Q8	Q9	Q10	Q11	Q12	Q13	Q14	Q15	Q16	Q17
2	3	2	2	2	2	4	1	1	3	2	4	3	4	3	2	4

Q18	Q19	Q20	Q21	Q22	Q23	Q24	Q25	Q26	Q27	Q28	Q29	Q30
2	4	3	4	2	4	3	2	4	3	1	2	3

31)a)larva , adult
b)Butterfly.

32)a)It help us to chew it down in to smaller pieces.
b)It was not cut in to smaller pieces and it has bigger surface area.

33)a)i)Matter ii)liquid
b)Oxygen.
c)Sound. It is not a solid as it does not have mass or occupy's space.

34)a)

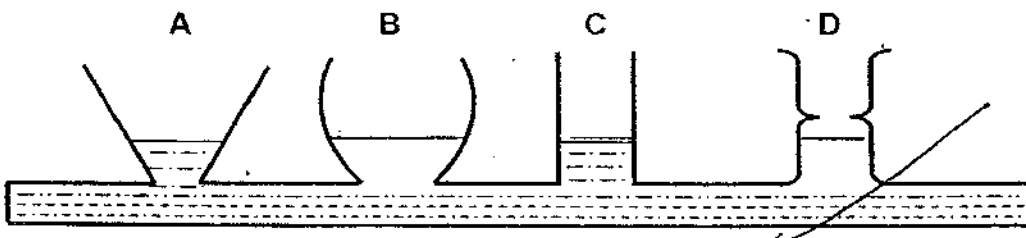

b)Water has no definite shape.

35)a)

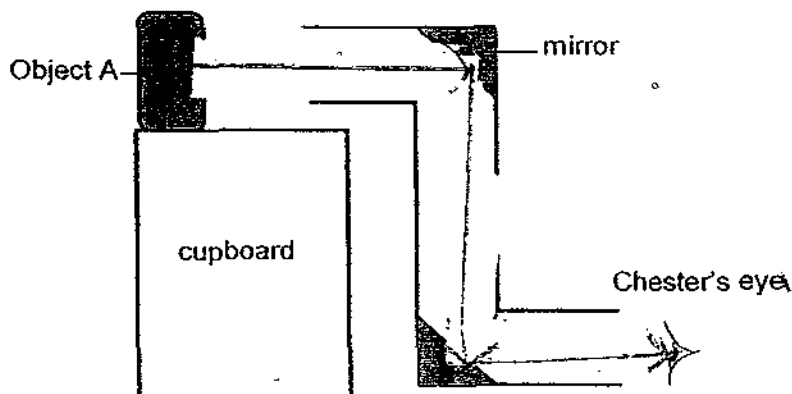

- b)i) Light travels in a set straight line.
- ii) Lights can be reflected.

36)Light sources

Fire works
Candle
Lightning
Lamp

Non-light sources

Moon
Gold ring

37)a)



- b) Move the cardboard towards the torchlight.

38)a) R: translucent S: opaque T: transparent

b) It was to act as a control that the results is caused by the different sheet used.

39)a) 15cm.

b) The sun was directly above the stick.

c) As the time of the day increases, the length of the shadow decreases before 12 p.m.

40)a) Light travels in a straight line.

b)i) Yes.

ii) The clear plastic sheet is transparent so we can still see the candle.

c) She would see cardboard B in stead of the candle.

41)a) The black cloth heat faster than the white cloth so it hotter and a higher temperature.

b) She should wear white coloured shirt as it will make her feel cooler.

42)a) Beaker B.

b) As feather is a bad conductor of heat if traps hot air inside so it will have a higher temperature.

43)a)Put bottle B in a basin of hot water.

b)The air in bottle B expands when heated and pushes the ink drop to move towards A.

44)Metal X expands more than metal Y when heated.

45)Metal expands when heated so when we pour hot water, there is heat given out so the steel lid expands and we could open jar easily.

46)a)8cm= B

15cm=A

20cm=C

b)Since metal is a better conductor of heat than glass, the balloons will inflate faster.