

Pei Chun Public School
Semestral Assessment 2 – 2009
Science
Primary 4

Name : _____ ()

Date : 29th October 2009

Class : Pr. 4 ()

Science Teacher : _____

Time : 1h 30 min

Section A (25 × 2 marks)

For questions 1 to 25, choose the most suitable answer and shade its number (1, 2, 3 or 4) on the Optical Answer Sheet (OAS) provided.

1. Study the classification chart below.

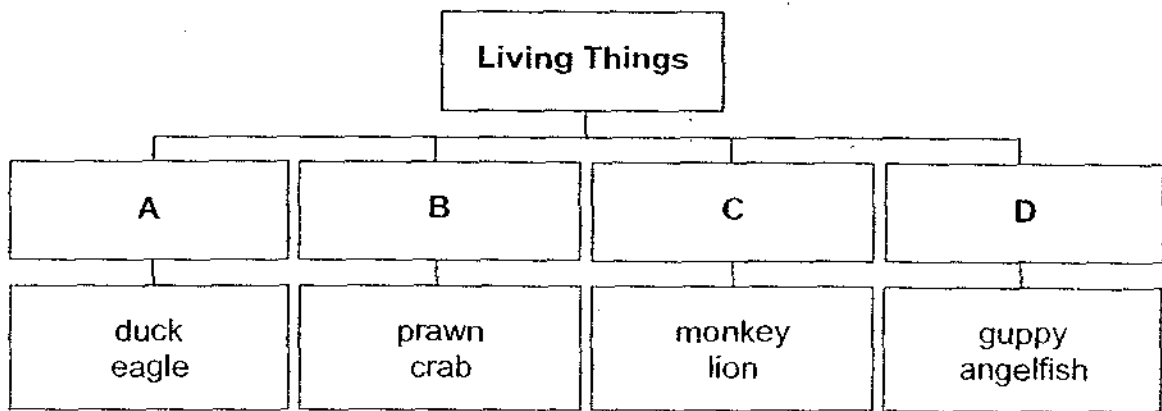

The living things are classified according to _____.

- (1) the way they reproduce
- (2) their body covering
- (3) the way they move
- (4) their sizes ()

2. Xuan put the following objects into a tank of water and made an observation.



bottle cork



ping pong ball



stone

Which of the following correctly describes Xuan's observation?

	bottle cork	ping pong ball	stone	
(1)	floats	sinks	sinks	()
(2)	sinks	floats	sinks	
(3)	floats	floats	sinks	
(4)	sinks	sinks	floats	

185

3. Sari has two bar magnets with poles, J, K, L and M. The magnets attract each other in the position shown below.

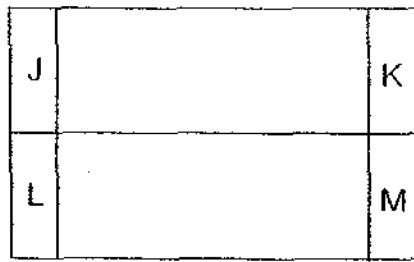

Sari can conclude that _____ are like poles.

- (1) J and L
- (2) J and K
- (3) K and L
- (4) K and M

()

4. Ahmad wants to make a temporary magnet using a strong bar magnet and an iron nail. Which of the following methods should he choose?

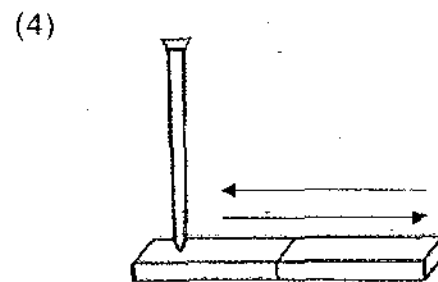
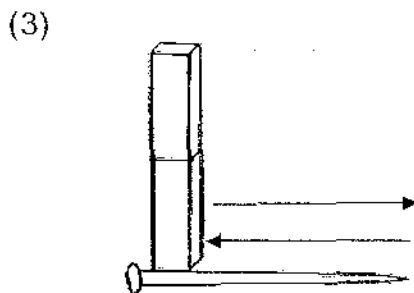
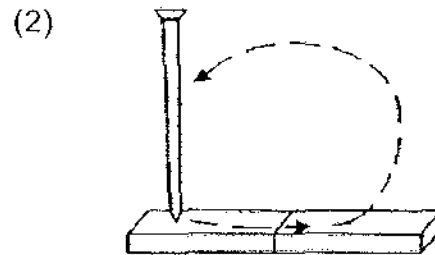
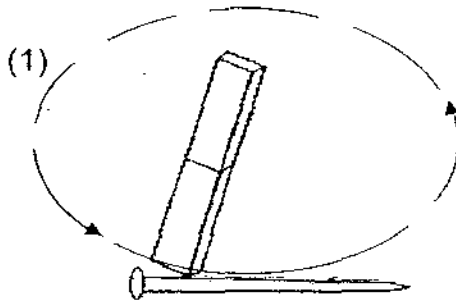

()

5. In the experiment below, Sumei put a plant into a beaker of red-coloured water. A few days later, she observed that the flowers and leaves had turned red.

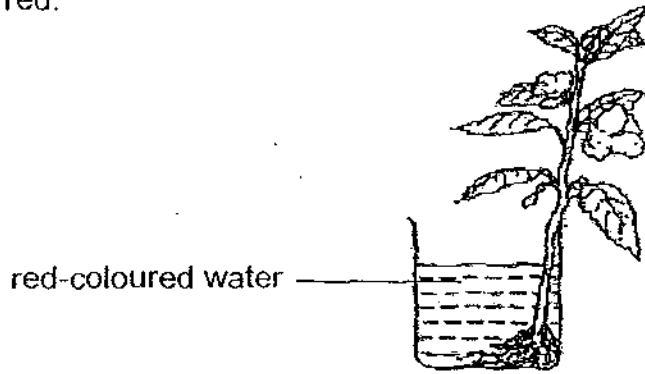

Which of the following statements describe correctly what had happened?

- A : Water was taken in by the roots.
- B : Water was transported by the leaves.
- C : Water was carried through the stem.
- D : Water was transported to the flowers and leaves.

- (1) A and D only
- (2) B and C only
- (3) A, C and D only
- (4) All of the above

()

6. Study the diagram of the human digestive system shown below.

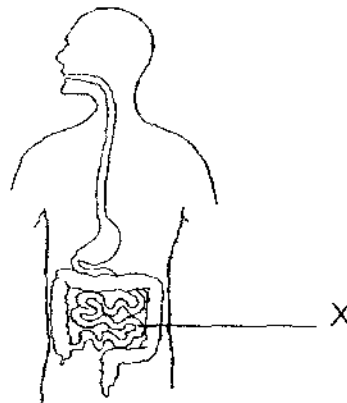

Which of the following represents the functions of organ X?

	Digestion of food	Absorption of digested food into blood	Absorption of water from undigested food
(1)	✓	✓	✗
(2)	✗	✓	✗
(3)	✓	✓	✓
(4)	✗	✗	✓

()

7. Which of the following sentences correctly describe(s) the functions of our body systems?

- A: The most important organ in the respiratory system is the heart.
- B: The muscular system works with the skeletal system to help us move.
- C: The circulatory system takes oxygen into the body and removes carbon dioxide.
- D: The digestive system carries food, water and oxygen to all parts of the body.

- (1) A only (2) B only
(3) C and D only (4) All of the above ()

8. The diagram below shows a stone.



The volume of the stone can be measured by using a _____.

- (1) ruler
- (2) syringe
- (3) weighing scale
- (4) measuring cylinder ()

9. Study the diagrams below.

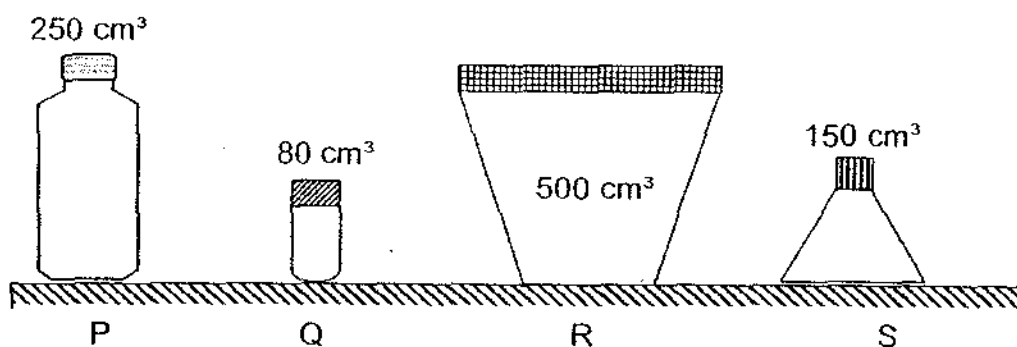

Which of the containers can be totally filled with 100 cm³ of air?

- (1) P and R only
- (2) Q and S only
- (3) P, R and S only
- (4) All of the above

()

10. In the experiment below, a rubber ball is balanced by a bar of soap.

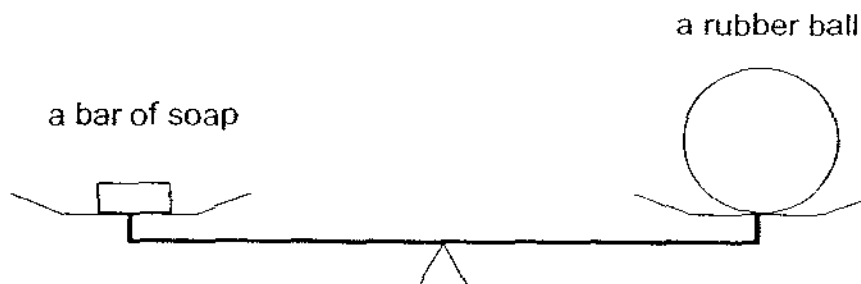

Based on the set-up, which of the following conclusions is true?

- (1) Matter with different volumes can have the same mass.
- (2) Matter with the same mass have the same volume.
- (3) Bigger objects have a smaller mass.
- (4) Smaller objects have a bigger mass.

()

11. Study the diagram below.

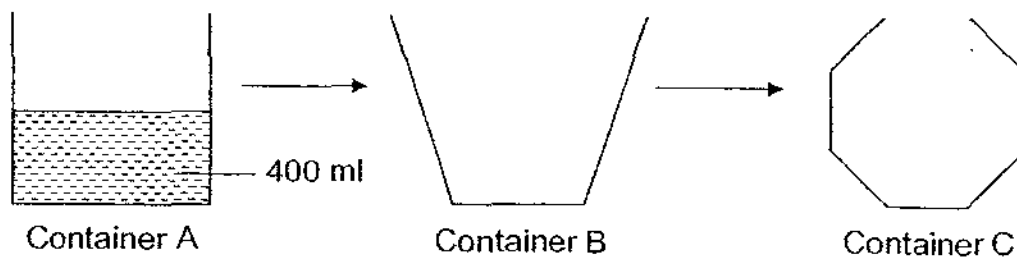

When the water was poured completely from Container A to Container B and then to Container C, there will be a change in the _____.

- A : mass of the water
- B : shape of the water
- C : volume of the water

- (1) A only
- (2) B only
- (3) A and C only
- (4) B and C only

()

12. Zaki carried out three experiments and recorded his observations in the table below.

Experiment	What he did	Observations
A	Waved an empty plastic bag about in the air.	The plastic bag became puffed up with air.
B	Squeezed an empty milk carton.	Air came out from a hole in the milk carton.
C	Put a small pot of soil in a large basin of water.	Air bubbles came out from the soil.

From the above observations, Zaki could conclude that air _____.

- (1) has mass
- (2) takes up space
- (3) can be compressed
- (4) is made up of different gases

()

13. Raha wanted to pack ten identical books into a box but found that she can only put in eight books as shown in the diagram below.

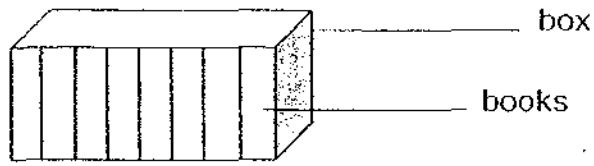

What are the reasons why she could not pack in the last two books?

- A : The books have mass.
- B : The books have definite volume.
- C : The books have a definite shape.
- D : The books cannot be compressed.

- (1) A and B only
- (2) B and C only
- (3) A, B and C only
- (4) B, C and D only

()

14. Study the diagrams below.

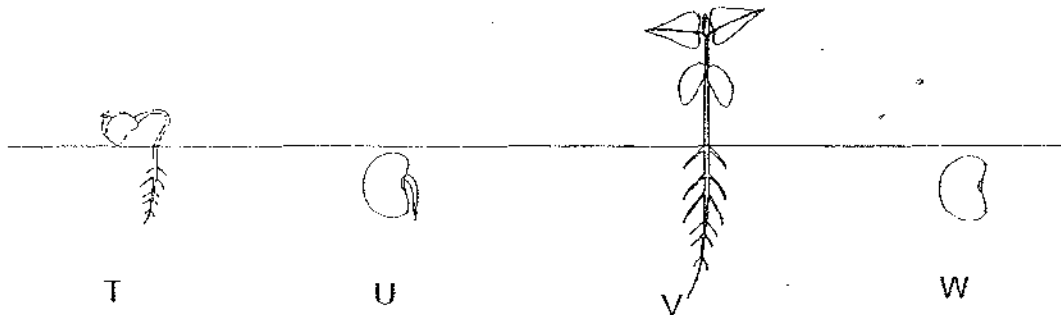

Which is the correct order of the growth of a bean plant?

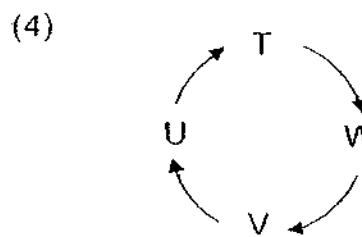
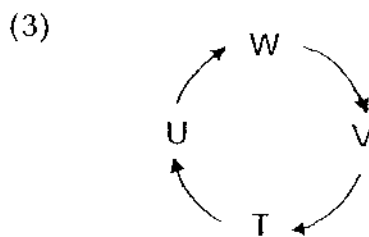
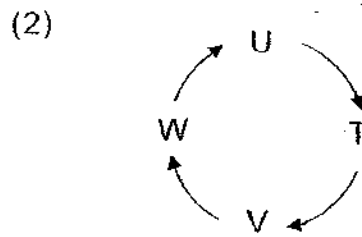
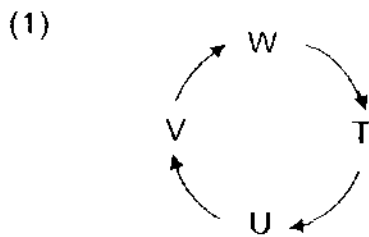

()

15. Sundram wanted to find out what type of soil was suitable for growing balsam plants. He planted a balsam plant in each of the pots, X, Y and Z. He put the same amount of soil in each pot. He watered them daily with the same amount of water.

	Pot X	Pot Y	Pot Z
Original height of plant	10 cm	10 cm	10 cm
Type of soil	garden soil	sand	clay
Size of pot	1025 cm ³	1050 cm ³	1000 cm ³
Location	open field	under a tree	near a pond

From the information given in the table above, why was the experiment not a fair one?



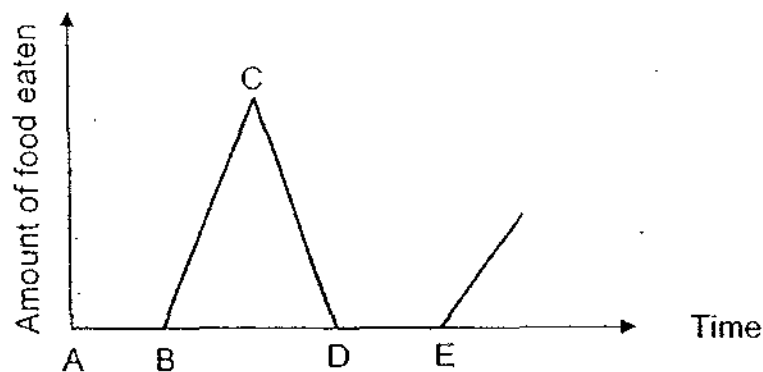

- (1) The size of the pots was different.
 - (2) The location of the plants was different.
 - (3) The type of soil used in each pot was different.
 - (4) The three pots were given the same amount of water. ()
16. The graph below shows the amount of food eaten by the young of a mosquito throughout the four stages of its life cycle.

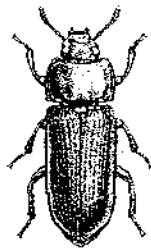
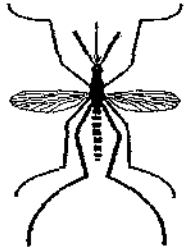
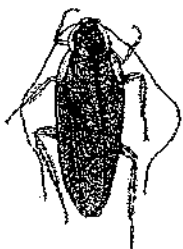

Which line in the graph shows the amount of food eaten by the mosquito in the pupa stage?

- (1) AB
- (2) BC
- (3) CD
- (4) DE ()

17. Study the classification table below.

Animals	
Insects with 3-stage life cycles	Insects with 4-stage life cycles
 <p>beetle</p>	 <p>mosquito</p>
 <p>cockroach</p>	 <p>dragonfly</p>
 <p>grasshopper</p>	 <p>moth</p>

Which of the following insects are wrongly classified?

- (1) beetle and dragonfly
- (2) cockroach and moth
- (3) mosquito and beetle
- (4) cockroach and dragonfly

()

18. Shuwen shone a torch on Object A. She observed that a shadow was formed. She repeated the experiment with Object B. She did not see any shadow on the screen.

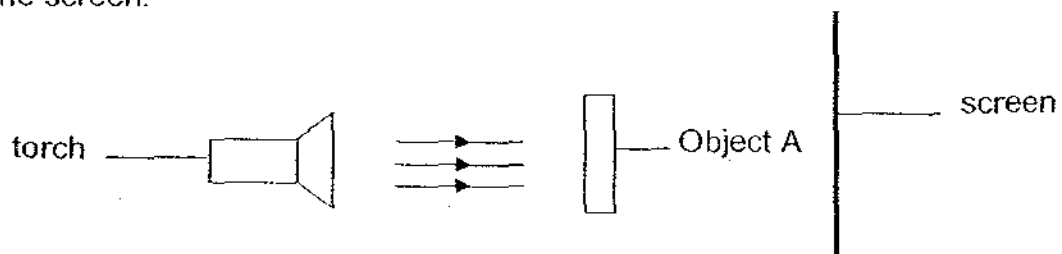

What was the best reason for her observation of Object B?

- (1) It was day time.
- (2) The object was opaque.
- (3) The light was not strong.
- (4) The object was transparent.

()

19. Veera carried out an experiment in a dark room.

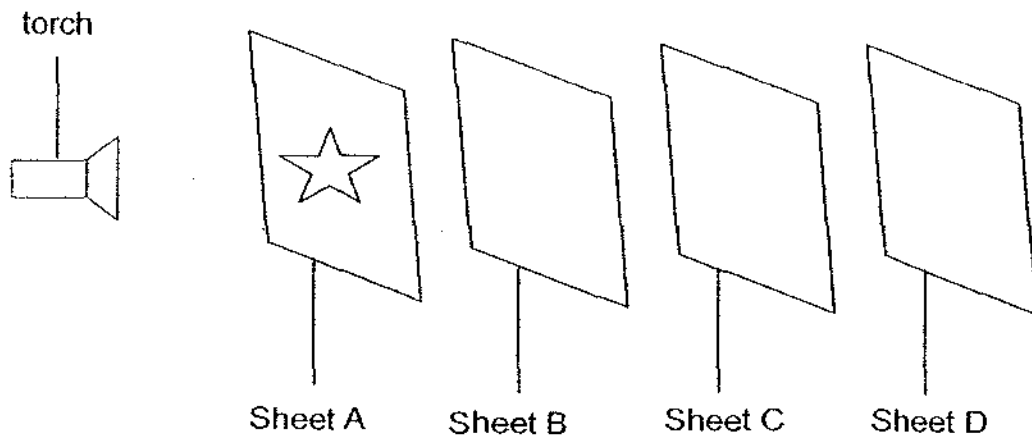

Veera arranged the sheets in a straight line. When the light was turned on, a bright star-shaped patch of light could be seen on Sheet C only.

Which of the following correctly describes the properties of the materials that the sheets were made of?

	Allows light to pass through	Does not allow light to pass through	Not possible to tell
(1)	B	A and C	D
(2)	B	C	A and D
(3)	A and D	C	B
(4)	A and B	D	C

20. The diagram below shows how a periscope helps Tom see the bat flying over his rooftop.

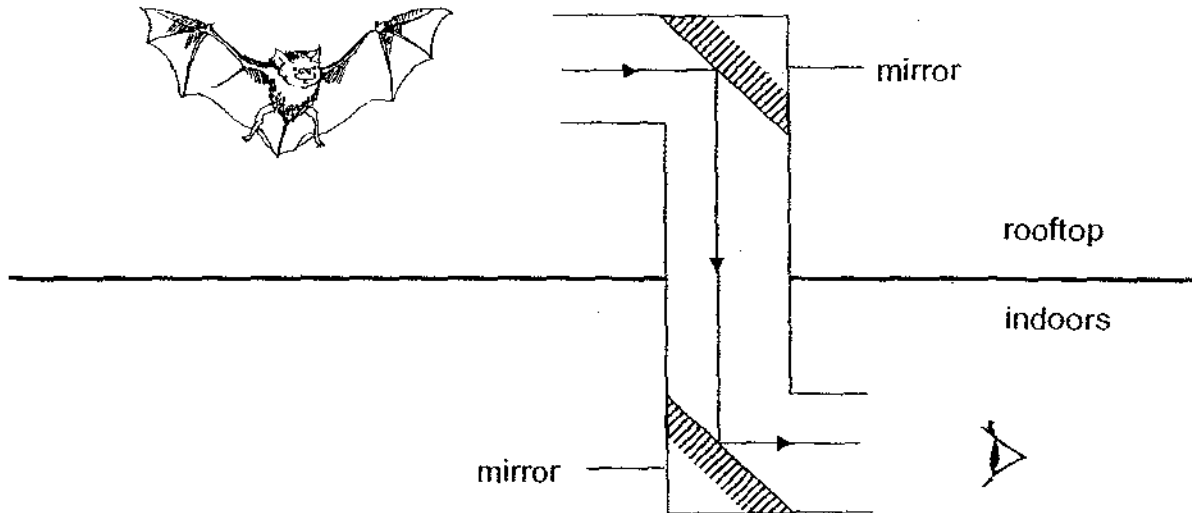

Based only on the diagram above, what can you conclude about the properties of light?

- S : Light does not have mass.
- T : Light can be reflected.
- U : Light travels in a straight line.

- (1) S only
- (2) T only
- (3) S and U only
- (4) T and U only

()

21. Study the diagram below.

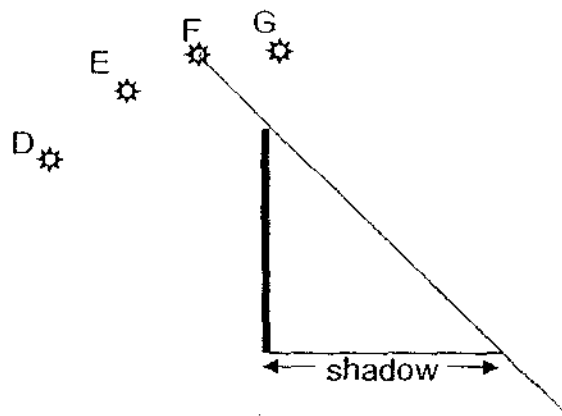

At which position was the Sun for the above shadow to be formed?

- (1) D
- (2) E
- (3) F
- (4) G

()

195

22. The diagram below shows a pavement.

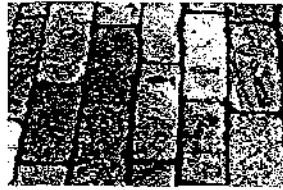

The gaps in between the concrete slabs are constructed to allow _____.

- (1) heat to flow through.
- (2) rain water to seep through.
- (3) space for expansion on a hot day.
- (4) space for contraction on a hot day.

()

23. Khairul conducted an experiment on two types of metal.

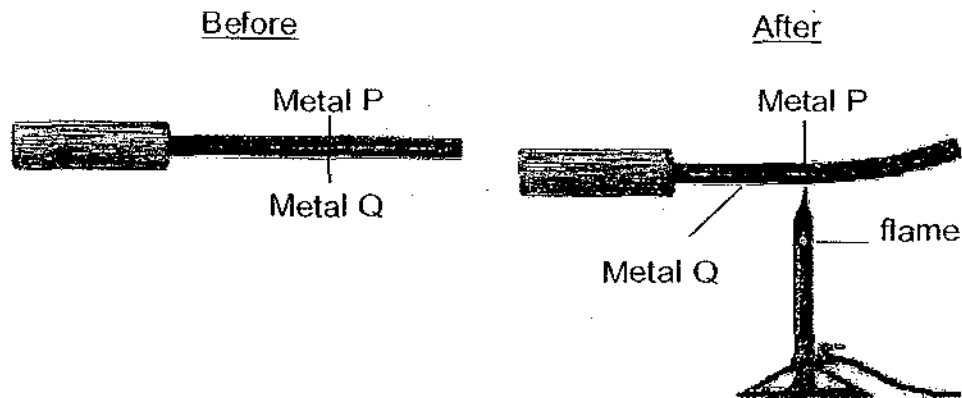

Which of the following statements is true?

- (1) Metal Q expands more than Metal P.
- (2) Metal P expands more than Metal Q.
- (3) Metal Q expands while Metal P contracts.
- (4) Metal P expands while Metal Q contracts.

()

24. A glass of hot water at 84°C is put in a basin of tap water at 24°C . After one hour, the temperature of the basin of water becomes 27°C .

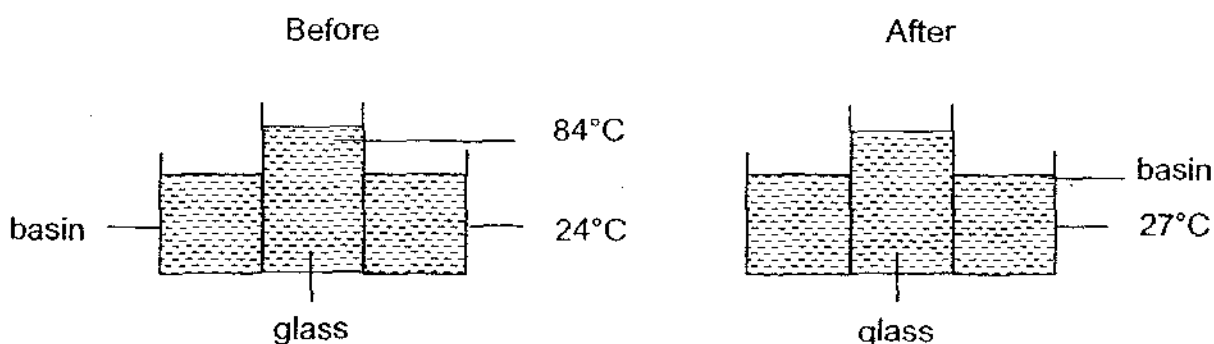

What would the temperature of the water in the glass be after one hour?

- (1) 108°C
 - (2) 84°C
 - (3) 27°C
 - (4) 24°C
- ()
25. Juxiang attached the same amount of wax to each end of a special rod as shown below.

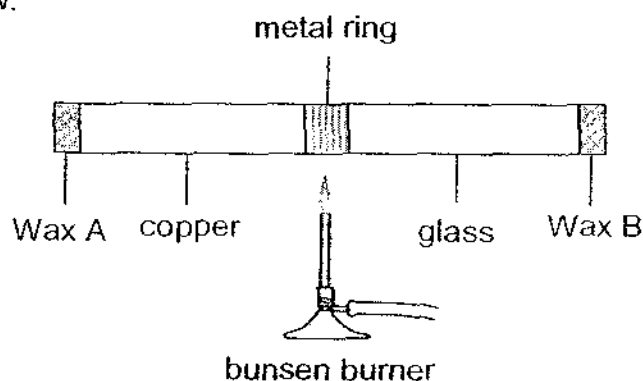

He then put a bunsen burner below the middle of the metal ring. After ten minutes, he observed that Wax A started to melt first.

Which of the following best explains the observation?

- (1) Glass is a poor conductor of heat.
 - (2) Copper is a poor conductor of heat.
 - (3) Glass is a better conductor of heat than copper.
 - (4) Copper is a better conductor of heat than glass.
- ()

For Questions 26 to 30, please refer to Booklet K.

End of Section A

Pei Chun Public School
Semestral Assessment 2 – 2009
Science
Primary 4

Name: _____ ()

Class: Pr 4 ()

Date: 29th October 2009

Time: 1 h 30 min

Science Teacher: _____

Parent's Signature: _____

Section A	60
Section B	30
Booklet K (excludes MCQs)	10
Total	100

Section B (30 marks)

For questions 31 to 40, write your answers in the spaces provided.

31. Sheena used the experiment shown below for an experiment on light.

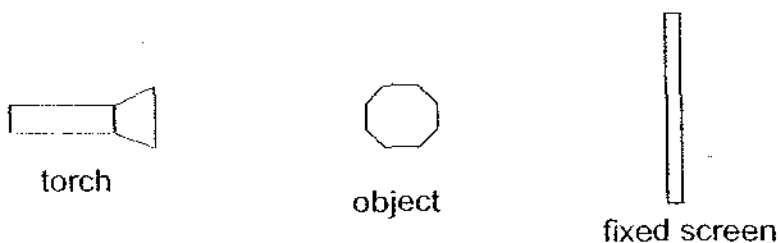

She found that she could increase the size of the shadow by bringing the torch nearer to the object.

Without changing any apparatus, state two other ways in which Sheena could increase the size of the shadow. (2 m)

- a) _____

- b) _____

32. Study the classification chart below.

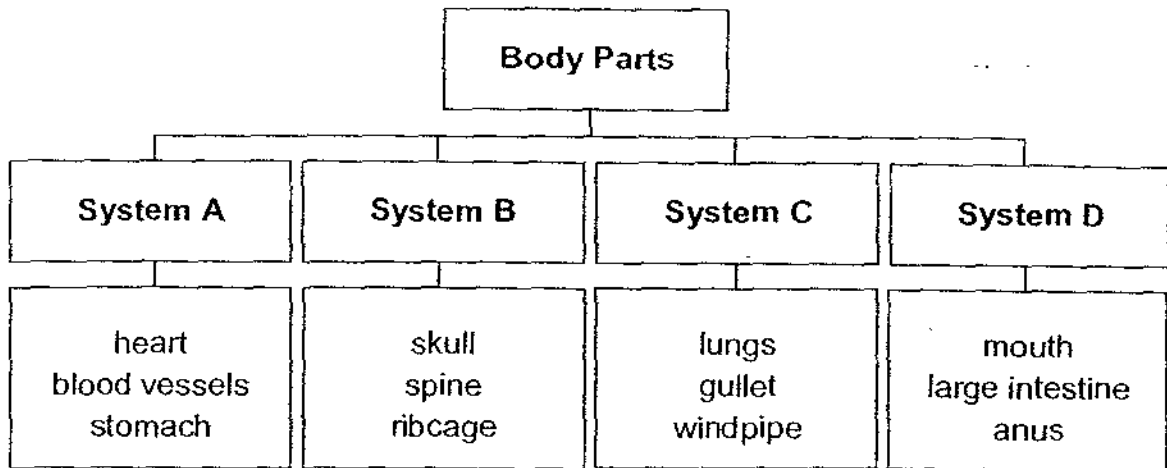

(a) Based on the classification chart above, identify two body parts that are wrongly classified. (1 m)

(b) Give the correct names for the systems, A, B, C and D. (2 m)

System A	
System B	
System C	
System D	

33. Study the diagram below.

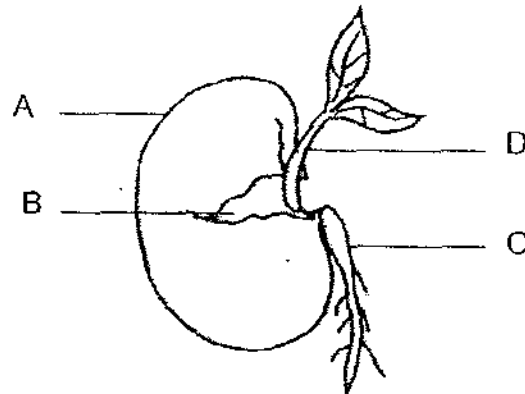

(a) Which part, A, B, C or D, provides food for the seedling? (½ m)

(b) Identify the part, A, B, C or D, which comes out first during germination. (½ m)

(c) State the conditions required for germination. (1 m)

(d) When will the seedling start to make its own food? (1 m)

34. Study the classification table below.

States of Matter	Examples
L	carbon dioxide, nitrogen
M	eraser, brick
N	alcohol, milk

(a) Which states of matter do L, M and N stand for? (1 m)

L : _____

M : _____

N : _____

(b) State one difference between the properties of L and N. (1 m)

35. Rahman put 300 g of soil into each of the three identical containers, A, B and C as shown below. He added 300 ml of water into each container. After twenty minutes, he observed that there was a change in the water level in each container. The new water levels are shown in the diagram below.

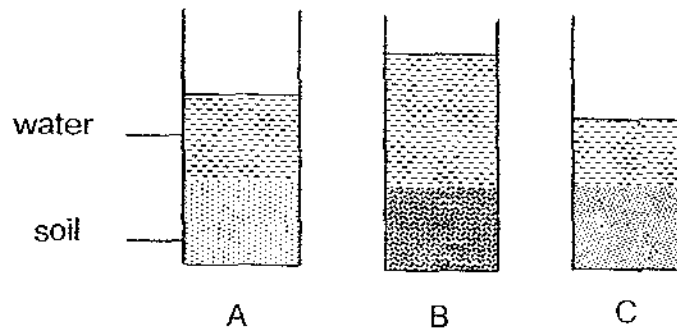

- (a). Which container had soil with the most air spaces? (1 m)

- (b) Explain your answer in (a). (1 m)

- (c) Besides using the same type of containers, name two variables that were kept constant in this experiment. (1 m)

36. The diagram shows an incomplete flow chart.

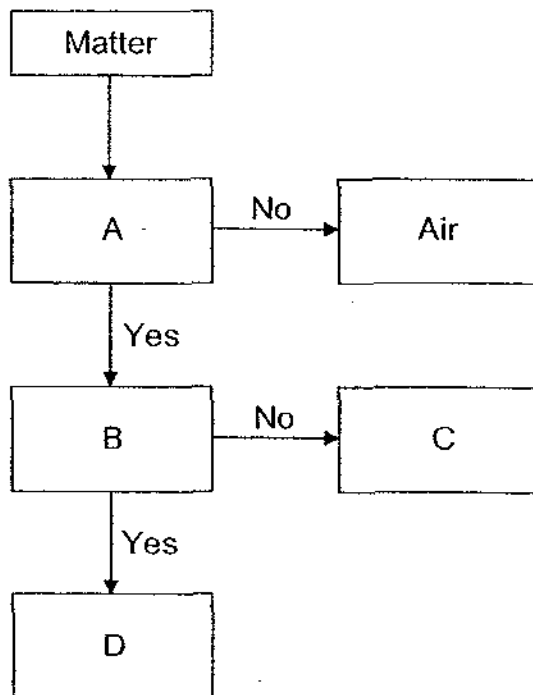

- (a) The information in the table below can replace the letters, A, B, C and D, in the flow chart. Match them with the correct letters. (2 m)

hot tea	
mug	
Does it have a definite shape?	
Does it have a definite volume?	

- (b) Shihui was going on a holiday. She packed her sponge pillow into her luggage. Why was she able to squeeze her pillow so that it occupied less space? Explain. (1 m)

37. The diagram shows part of one system in the human body.

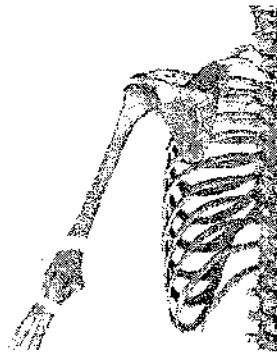

- (a) Name another system, not shown on the diagram, that helps in the movement of the arm. (1 m)

- (b) On the diagram, circle the part which allow you to bend or straighten your arm at the elbow. (1 m)

- (c) State another function of the system shown in the diagram. (1 m)

38. The diagrams below show a nymph and an adult of a cockroach.



(a) One difference between the cockroach and the nymph is the difference in sizes of the body parts. What is another difference? (1 m)

(b) Why does the nymph moult? (1 m)

(c) Match the adult insects to its young. (2 m)

Adult

Young



• •

• •

• •

• •

40. Sam used the two identical set-ups shown below for an experiment. He wrapped the bottom of the flask in Set-up A with a piece of cloth at 80°C . He also wrapped the bottom of the flask in Set-up B with a piece of cloth at 0°C .

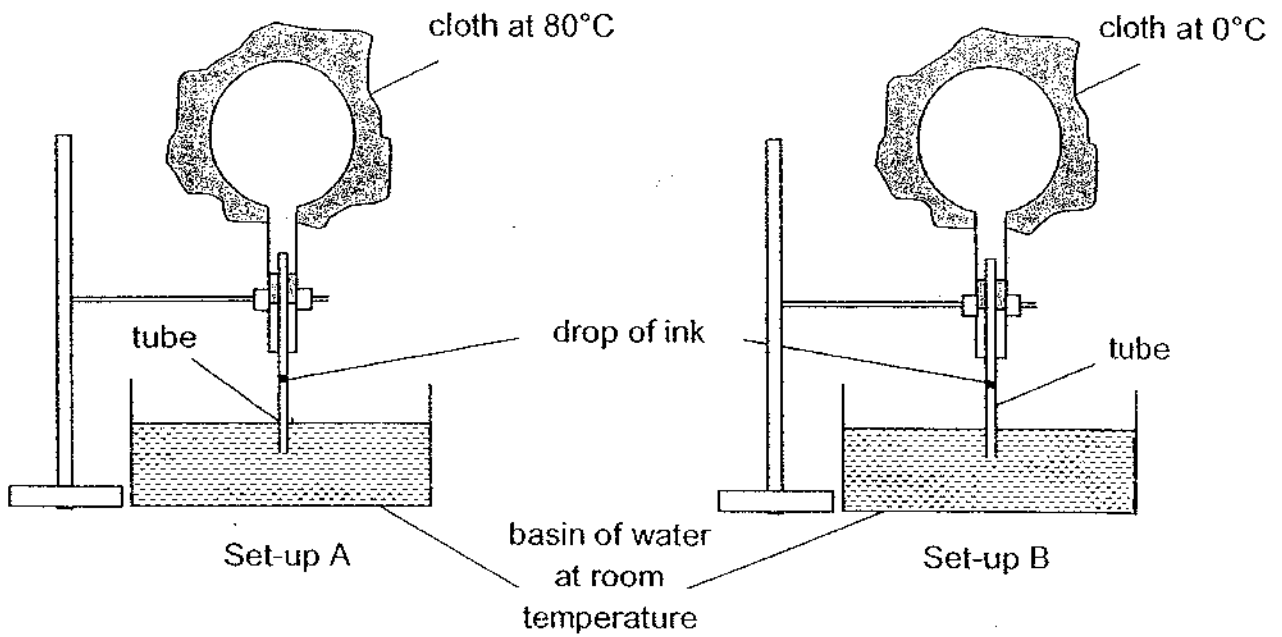

Write down Sam's observation of the drop of ink in both Set-ups.

- (a) (i) The drop of ink in Set-up A. (1 m)

- ii) Explain your answer in (a)(i)

- (b) (i) The drop of ink in Set-up B. (1 m)

- ii) Explain your answer in (b)(i). (1 m)

For Questions 41 to 44, please refer to Booklet K.

End of Section B

ANSWER SHEET

EXAM PAPER 2009

**SCHOOL : PEI CHUN PRIMARY
SUBJECT : PRIMARY 4 SCIENCE**

TERM : SA2

Q1	Q2	Q3	Q4	Q5	Q6	Q7	Q8	Q9	Q10	Q11	Q12	Q13	Q14	Q15	Q16	Q17
2	3	3	1	3	1	2	4	4	1	2	2	4	2	2	4	1

Q18	Q19	Q20	Q21	Q22	Q23	Q24	Q25
4	1	4	3	3	1	3	4

31)a)She could bring the object closer to the torch.
b)She could bring both the torch and the object further away from the fired screen.

32)a)The stomach and the gullet.
b)A: Circulatory System. B: Skeletal System.
C: Respiratory System. D: Digestive System.

33)a)Part B.
b)Part C.
c)Air, water and warmth.
d)It will start to make its own food after its leaves have fully developed which will help make food for the plant.

34)a)L: Gas M: Solid N: Liquid
b)N has a definite volume while L does not.

35)a)Container C.
b)Container B has the highest water level, which means the soil, having very little air spaces, did not allow the water to enter much. Container A was lower the container B but the lowest was container C, which the soil had the most number of air spaces.
c)The amount of soil.

36)a)C, D, B, A

b)When Shihui squeezed the sponge pillow, the air in the air spaces in the sponge pillow was forced out, thus allowing the sponge pillow to occupy less space.

37)a)The muscular system.

b)

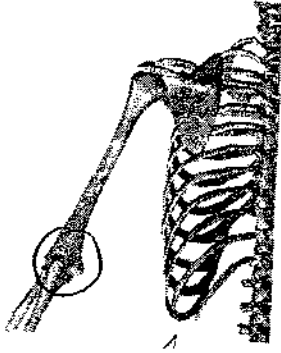

c)It helps to keep the body upright.

38)a)The cockroach can fly while the nymph cannot.

b)It gets too big for its skin.

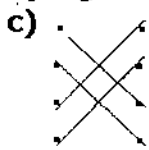

39)a)As the number of coils a round the magnet and the number of the batteries increases, the strength of the magnet increases.

b)P and S.

c)P→S→R→Q

40)a)i)The ink drop will go down into the basin of water.

ii)The air in the flask expanded and push the drop of ink out of the tube.

b)i)The drop of ink will go down little before going up.

ii)The flask contracted due to the 0°C cloth and forced the air to push the drop of ink down, then the air contracted and forced drop of ink up.