



NAN HUA PRIMARY SCHOOL
SEMESTRAL ASSESSMENT 2 – 2010
PRIMARY 5

MATHEMATICS

Paper 1

Section A: 15 Multiple Choice Questions (20 marks)

Section B: 15 Short Answer Questions (20 marks)

Total Time for Paper 1: 50 minutes

INSTRUCTION TO CANDIDATES

1. Write your name and index number in the space provided.
2. Do not turn over the page until you are told to do so.
3. Follow all instructions carefully.
4. Answer all questions.
5. Shade your answers in the Optical Answer Sheet (OAS) provided for Questions 1-15.
6. You are not allowed to use calculator for Paper 1.

Marks Obtained

Paper 1		/ 40
Paper 2		/ 60
Total		/ 100

Name : _____ ()

Class : _____

Date : 27 October 2010

Parent's Signature: _____

Section A (20 marks)

Questions 1 to 10 carry 1 mark each.

Questions 11 to 15 carry 2 marks each.

For each question, four options are given. One of them is the correct answer.

Make your choice (1, 2, 3 or 4) and shade on the oval (1, 2, 3 or 4) on the Optical Answer Sheet (OAS).

1. During a soccer match, the number of spectators in the stadium, when rounded off to the nearest thousand, is 79 000. Which of these is a possible number of the spectators ?

- (1) 78 049
- (2) 78 490
- (3) 79 409
- (4) 79 904

2. Which of the following decimal has the **greatest** value ?

- (1) 2.01
- (2) 2.11
- (3) 2.011
- (4) 2.101

3. Find the sum of all the common factors of 18 and 30.

- (1) 12
- (2) 11
- (3) 6
- (4) 5

4. How many more boxes must be shaded to make $\frac{5}{7}$ of the figure below shaded ?

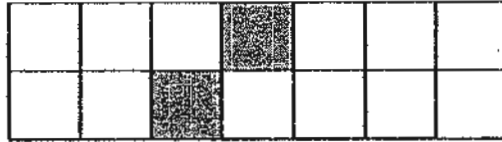

- (1) 10
(2) 8
(3) 3
(4) 4
5. Find the value of $24 + 36 \div 3 \times 6 - 2$.
- (1) 72
(2) 94
(3) 118
(4) 214
6. Kelly's mass is $\frac{5}{7}$ of Peter's mass. What is the ratio of Kelly's mass to the total mass of the two children ?
- (1) 5 : 7
(2) 7 : 5
(3) 5 : 12
(4) 12 : 5

7. In the triangle below, not drawn to scale, $AC = BC$ and $\angle BAC = 56^\circ$.

What is the value of $\angle ACB$? (The figure is not drawn to scale.)

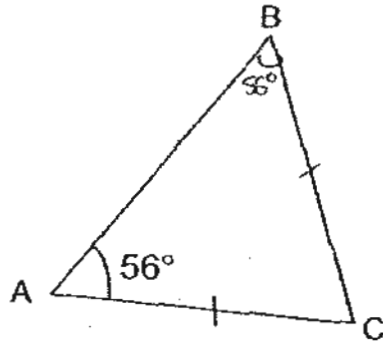

- (1) 62°
- (2) 68°
- (3) 112°
- (4) 124°

8. A fruiterer sold oranges in boxes of 3 and each box cost \$1.20.

Find the maximum number of oranges that I could have bought with \$10?

- (1) 8
- (2) 9
- (3) 24
- (4) 25

9. The figure below is not drawn to scale. Lines PQ and ST are straight lines. Which two angles add up to 90° ?

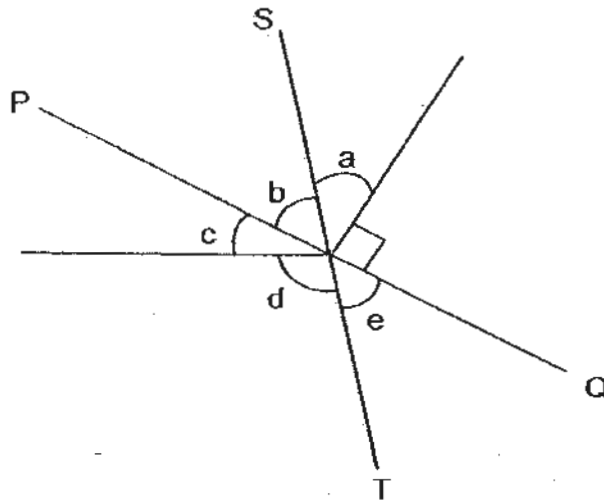

- (1) $\angle b$ and $\angle c$
- (2) $\angle c$ and $\angle e$
- (3) $\angle a$ and $\angle c$
- (4) $\angle a$ and $\angle e$
10. Jason spent 40% of his money on some cards and had \$30 left. How much money had he at first ?
- (1) \$12
- (2) \$20
- (3) \$50
- (4) \$75

11. Look at the figure below. The area of $\triangle ACF$ is equal to _____.

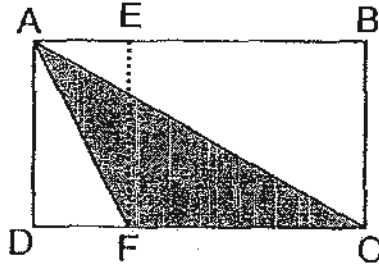

- (1) the area of rectangle AEFD
- (2) the area of rectangle ABCD
- (3) $\frac{1}{2}$ of the area of rectangle ABCD
- (4) $\frac{1}{2}$ of the area of rectangle BCFE

12. The average mass of 4 boys is 36 kg. When another boy who has a mass of 26 kg joins the group, what is the average mass of the new group of boys ?

- (1) 62 kg
- (2) 60 kg
- (3) 42kg
- (4) 34 kg

13. What is the maximum number of 2-cm cubes that can be cut from a cuboid measuring 8 cm by 6 cm by 3 cm ?

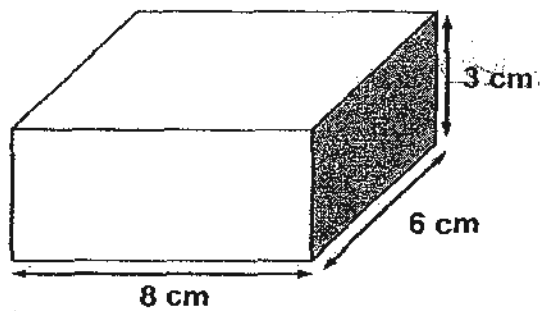

- (1) 8 cubes
(2) 12 cubes
(3) 18 cubes
(4) 72 cubes
14. Joelle went shopping with a sum of money. She spent $\frac{2}{5}$ of it on a pair of shoes and $\frac{1}{3}$ of the remainder on a wallet. If she had \$20 left, what was the cost of the pair of shoes ?
- (1) \$ 55
(2) \$ 30
(3) \$ 20
(4) \$ 12

15. Mrs Li bought 1.6 kg of red and green beans. 30% of the beans were green. After Mrs Li used some of the green beans to make a dessert, only 20% of the beans left were green. How much green beans did Mrs Li use ?

- (1) 160 g
- (2) 200 g
- (3) 280 g
- (4) 480 g

Questions 16 to 25 carry 1 mark each. Write your answers in the spaces provided. For questions which require units, give your answers in the units stated. [10 marks]

Do not write in this space

16. Find the sum of 25 tens and 37 tenths.

Ans : _____

17. The graph below shows the number of pupils who were absent in 4 levels on a certain day. If 94 pupils were absent on that day, how many pupils were absent in primary 3 ?

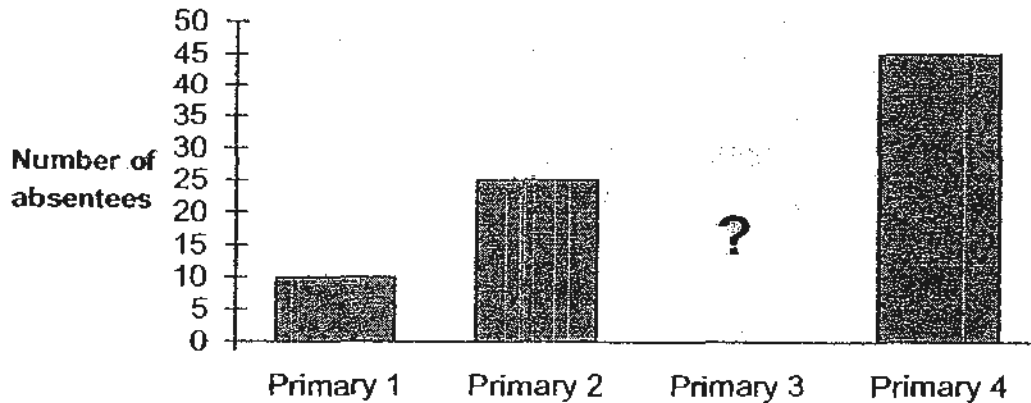

Ans : _____ pupils

18. Find the sum of the following numbers.

$$12 + 14 + 16 + 12 + 14 + 16 + 12 + 14 + 16 + 12 + 14 + 16 + 12 + 14 + 16$$

Ans : _____

Score:

19. A grandfather clock takes 12 seconds to strike 5 times from the first to the last stroke. How long will it take to strike 10 times ?

Do not write in this space

Ans : _____ seconds

20. The figure below shows 7 shaded squares. Shade 2 more squares to complete the figure so that the dotted line, AB, is a line of symmetry.

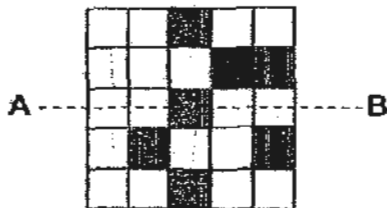

21. The average of 4 numbers is 9. The first 2 numbers are the same. If the other numbers are 6 and 8, find the first number.

Ans : _____

Score:

22. $\frac{2}{5}$ of Alice's money is equal to $\frac{1}{3}$ of Bob's money.
What is the ratio of Alice's money to Bob's money ?

Do not
write in
this space

Ans : _____

23.



Darren was at the park facing the shopping centre. If he made a 270° turn in the clockwise direction, he would be facing the _____.

Ans : _____

Score:

Do not
write in
this space

24. Ben is 0.43 m shorter than Kathy. If their total height is 247 cm, find the height of Ben in metres.

Ans : _____ m

25. The figure below is drawn on a square grid.
How many pairs of parallel lines are there in the figure?

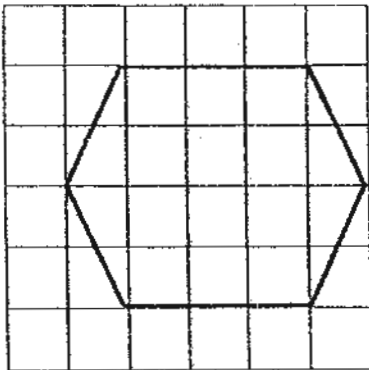

Ans : _____

Score:

Questions 26 to 30 carry 2 marks each. Show your workings clearly in the space provided for each question and write your answers in the spaces provided. For questions which require units, give your answers in the units stated.

[10 marks]

Do not write in this space

26. When a number is divided by 7, the quotient is 111 with no remainder. What is the remainder when the same number is divided by 8?

Ans : _____

27. The figure is made up of 2 identical rectangles. Find the total area of the shaded parts.

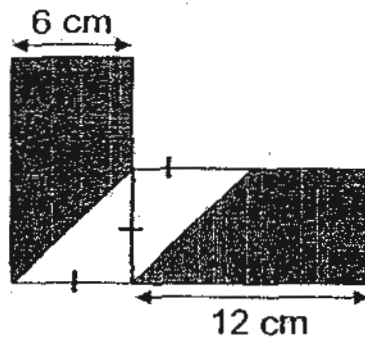

Ans : _____ cm^2

Score:

28.

MID-YEAR SALE



All items going at
20% discount

Usual Price: \$100

Do not write in this space

Jane bought the dress as shown in the advertisement above. If she still had to pay GST of 7% after the discount, how much did she pay for the dress?

Ans : \$ _____

29. Kathy used a ribbon of length 132 cm to tie a cube with a bow, as shown below. If 12 cm of the string was used to tie the bow, find the area of the shaded part of the cube.

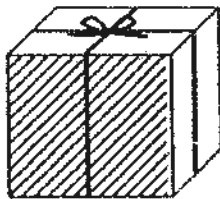

Ans : _____ cm²

Score:

30. The table below shows the distribution of children per household in an estate.

Do not write
in this space

No. of Children	Household
1	30
2	60
3	10
4	5

What percentage of the children in the estate are from households with more than 2 children ?

Ans : _____%

Score:



NAN HUA PRIMARY SCHOOL
SEMESTRAL ASSESSMENT 2 – 2010
PRIMARY 5

MATHEMATICS

Paper 2

Total Time for Paper 2: 1 hour 40 minutes

INSTRUCTION TO CANDIDATES

1. Write your name and index number in the space provided.
2. Do not turn over the page until you are told to do so.
3. Follow all instructions carefully
4. Answer all questions and show your workings clearly.
5. You are allowed to use a calculator.

Marks Obtained

Total		/ 60
-------	--	------

Name : _____ ()

Class : _____

Date : 27 Oct 2010

Questions 1 to 5 carry 2 marks each. Show your workings clearly in the space provided for each question and write your answers in the spaces provided. For questions which require units, give your answers in the units stated. [10 marks]

Do not write in this space

- Each side of a square table can seat a child. If 8 such tables are joined together in a row to form a long table, how many children can be seated around the long table?

Ans : _____ children

- Study the pattern in the figure below. What is the missing number?

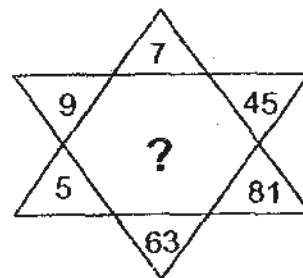
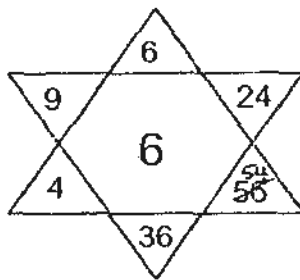
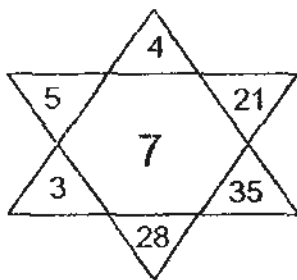

Answer: _____

3. In the figure below not drawn to scale, a rectangular piece of paper was folded. Find $\angle a$.

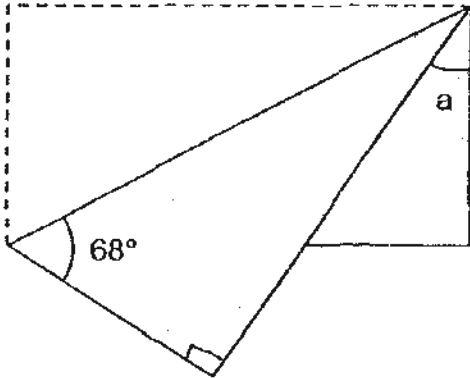

Answer: _____ °

Do not write
in this space

4. The base of the triangle below is 3 cm and its height is 4 cm. What is the maximum number of such triangles which can be cut from a sheet of paper measuring 25 cm by 16 cm ?

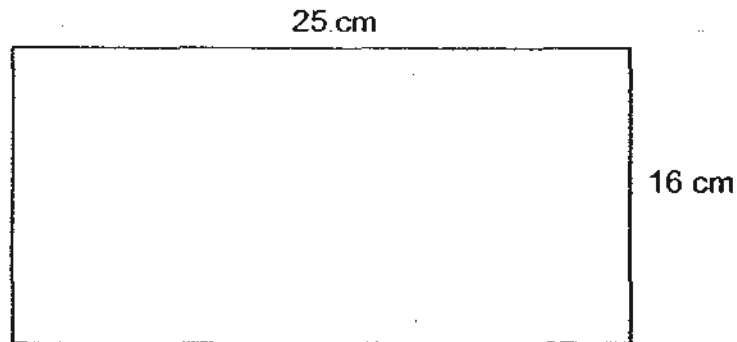
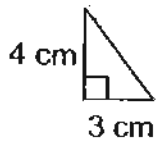

Answer: _____ triangles

Do not write
in this space

5. In the figure below, each dot is represented by a letter.

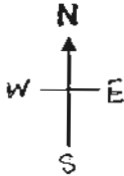
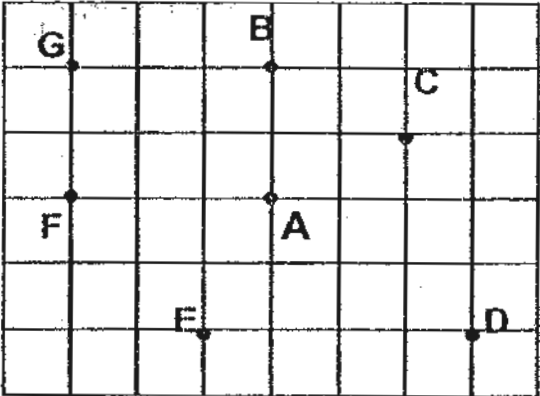

Which letter is located to the north-west of A ?

Answer: Letter : _____

For questions 6 to 18, show your workings clearly in the space provided for each question and write your answers in the spaces provided.

The number of marks available is shown in the brackets [] at the end of each question or part-question.

[50 marks]

Do not write
in this space

6. John had 450 stickers and Keith had 780 stickers. Keith gave some of his stickers to John so that both of them had the same number of stickers. How many stickers does John have now?

Ans: _____ [3]

7. Ryan spent \$ 252 on a camera. He gave $\frac{1}{7}$ of his remaining money to charity. If he still had \$ 42 left, how much had he at first ?

Ans: _____ [3]

8. A piece of rope 8.16 m long was cut into 3 pieces. The 1st piece was 3 times as long as the 2nd piece. The 3rd piece was $\frac{1}{3}$ as long as the original rope. How long was the 2nd piece of rope? (Give your answer in metres.)

Do not write
in this space

Ans: _____ [3]

9. Dayan had twenty coins. Some were 50-cent coins and some were 20-cent coins. The value of the 50-cent coins was \$ 4.40 more than the 20-cent coins, how many 50-cent coins did he have?

Ans: _____ [3]

Do not write
in this space

10. The container, as shown below, is $\frac{2}{3}$ filled with water.
How much more water is needed to completely fill the container ?
Express your answer in litres.

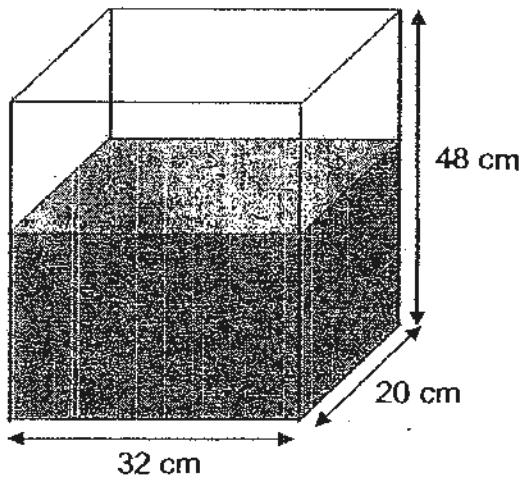

Answer: _____ [3]

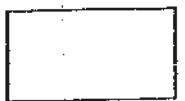

79a

11. Charmaine and Jolene had some stamps at first. After Jolene had given ~~68~~^{stamps} to Charmaine, the ratio of the number of stamps that Charmaine had to the number of stamps that Jolene had became 5 : 1. Given that Charmaine had 1 248 stamps more than Jolene at first, find the number of stamps Jolene had at first.

Do not write
in this space

Answer: _____ [3]

Do not write
in this space

12. In the figure below, not drawn to scale, ABCE and CDEF are rhombuses.

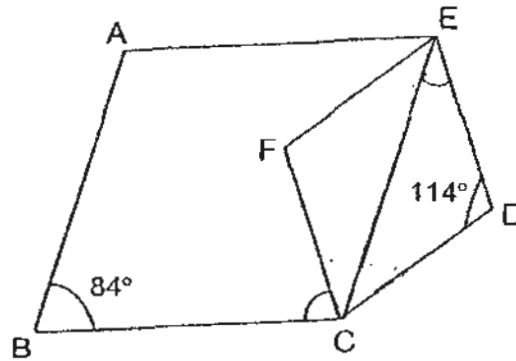

(a) Find $\angle CED$.

(b) Find $\angle BCF$.

Ans: (a) _____ [2]

(b) _____ [2]



Do not write
in this space

13. Diego bought some apples, mangoes and pears in the ratio 3 : 1 : 2. Each apple cost 50¢ and each pear cost 10¢ more than an apple. The cost of each mango was \$1. If the total amount of money spent by him was \$14.80, how many pears did he buy?

Ans: _____ [4]

14. Study the pattern below carefully.

Do not write
in this space

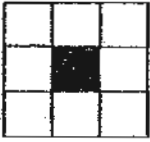

Pattern 1

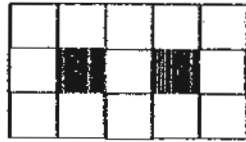

Pattern 2

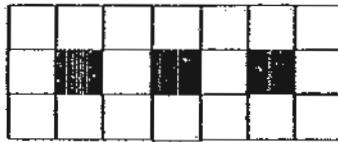

Pattern 3

a) Complete the following table for Pattern 5.

Pattern Number	Number of black tiles	Number of white tiles	Difference between the white and the black tiles
1	1	8	7
2	2	13	11
3	3	18	15
5	5	(i) _____	(ii) _____

b) Find the difference between the white and the black tiles in **Pattern 50**.

Ans: a) (i) _____ [1]

(ii) _____ [1]

b) _____ [2]

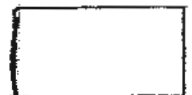

15. A square and four right-angled isosceles triangles formed a rectangle as shown below. If the perimeter of the square is 24 cm, find the area of the rectangle formed.

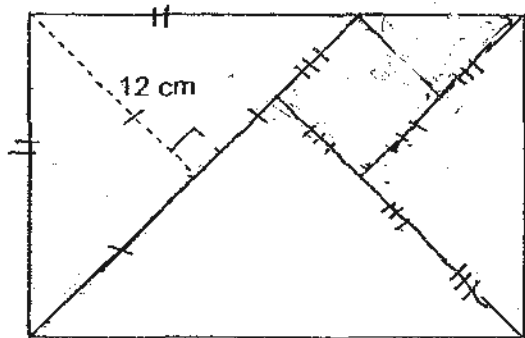

Do not write
in this space

Ans: _____ (5m)



Do not write
in this space

16. Mr Bond had some pencils, rulers and erasers. 60% of the stationery were pencils, 30% of them were rulers while the rest were erasers. There were 240 more pencils than erasers. After Mr Bond sold some of his pencils, 40% of the stationery left were pencils.

- (a) How many pencils did Mr Bond have at first ?
- (b) How many pencils were sold ?

Ans: (a) _____(2)

(b) _____(3)



Do not write
in this space

17. Mrs Tan made a jar of cookies in the morning. Out of the $\frac{2}{7}$ which she took out, 18 were given away and the ~~rest of the~~ ^{remaining} ~~52 tarts~~ ^{cookies} were eaten by her children. In the evening, she made another lot of cookies and she put $\frac{1}{3}$ of them into the same jar as those made in the morning. After this, the total number of cookies in the jar was 204. How many cookies did she make in the ~~afternoon~~ ^{evening} ?

Ans: _____ (5)

piggy bank

18. A box has a total of 2 562 coins consisting of one-dollar coins, fifty-cent and twenty-cent coins. $\frac{3}{7}$ of the one-dollar coins and 32 of the fifty-cent coins are taken out. 20 more twenty-cent coins are put in. After that, there is an equal number of one-dollar, fifty-cent and twenty-cent coins in the piggy bank. How many of each type of coins are there in the piggy bank at first ?

Do not write
in this space.

Ans: No. of one-dollar coins → _____

No. of fifty-cent coins → _____

No. of twenty-cent coins → _____ [5]

ANSWER SHEET

EXAM PAPER 2010

SCHOOL : NAN HUA PRIMARY
 SUBJECT : PRIMARY 5 MATHEMATICS

TERM : SA2

Q1	Q2	Q3	Q4	Q5	Q6	Q7	Q8	Q9	Q10	Q11	Q12	Q13	Q14	Q15
3	2	1	2	2	3	2	3	4	3	4	4	2	3	2

16) 253.7 17) 14 18) 210 19) 27

20)

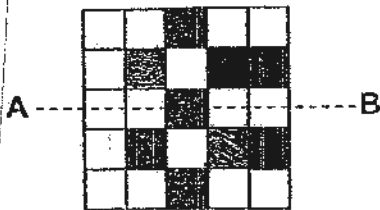

21) 11 22) 5:6 23) bank 24) 1.02 25) 3 pairs 26) 1

27) 108 28) 85.60 29) 225 30) 25

Paper 2

1) 18 2) 9 3) 46 4) 64 5) G 6) 615
 7) \$301 8) 1.36m 9) 12 10) 10.24 11) 414 12a) 33
 12b) 63 13) 8 14i) 28 14ii) 23 14b) 203 15) 432
 16a) 288 16b) 60 17) 87 18) \$1 → 1190, \$0.50 → 712, \$0.20 → 660