

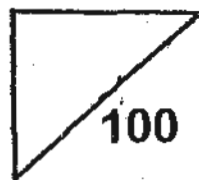

Rosyth School
First Semestral Assessment for 2010
SCIENCE
Primary 3

Name: _____

Total
Marks:



Class: Pr 3- _____ Register No. _____ Duration: 1 h 30 min

Date: 13 May 2010 Parent's Signature: _____

Instructions to Pupils:

1. Do not open the booklets until you are told to do so.
2. Follow all instructions carefully.
3. This paper consists of 2 booklets, Booklet A and Booklet B.
4. For questions 1 to 30 in Booklet A, shade the correct ovals on the Optical Answer Sheet (OAS) provided using a 2B pencil.
5. For questions 31 to 44, write your answers in the spaces given in the Booklet B.

	Maximum	Marks Obtained
Booklet A	60 marks	
Booklet B	40 marks	
Total	100 marks	

* This booklet consists of 16 pages.

This paper is not to be reproduced in part or whole without the permission of the Principal.

PART I (60 MARKS)

For each question from 1 to 30, four options are given. One of them is the correct answer. Make your choice (1, 2, 3 or 4). **Shade the correct answer in the optical answer sheet (OAS) using a pencil.**

1. Which of the following are the characteristics of all living things?

- A: They can grow.
- B: They can make their own food.
- C: They can respond to changes around them.
- D: They can move from place to place on their own.

- (1) A and B only
- (2) A and C only
- (3) A, B and C only
- (4) B, C and D only

2. Study the classification chart below carefully.

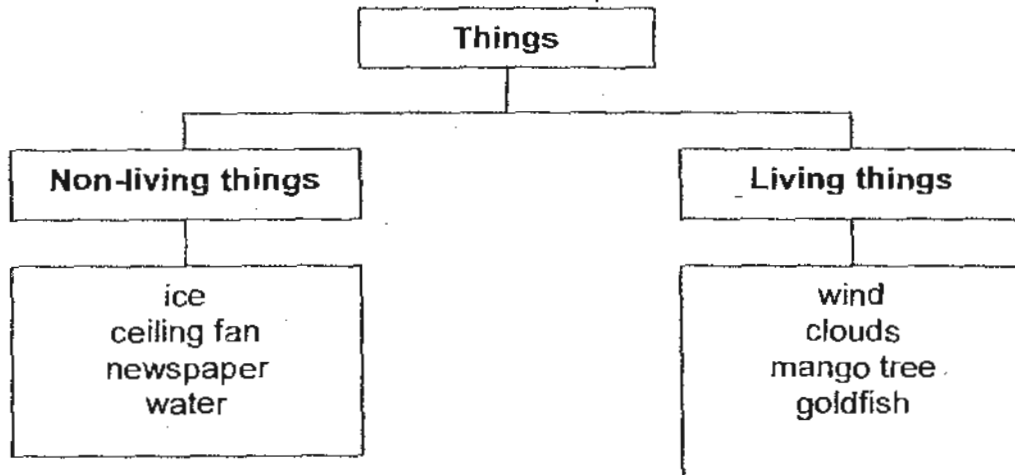

Which of the above have been classified wrongly?

- (1) Ice and water only
- (2) Wind and clouds only
- (3) Ice, ceiling fan and water only
- (4) Ice, water and mango tree only

3. Siti placed two things, X and Y, into two containers. She also placed the same type and same amount of food into each container. She then made some observations of X and Y as shown below.

X	Y
Moves slowly	Does not move
Feeds on the food	Does not feed on the food
Grew bigger after 1 week	No change in size after 1 week

Based on the information in the table above, which of the following could X and Y be?

	X	Y
(1)	coin	snail
(2)	snail	ant
(3)	marble	stone
(4)	terrapiin	pebble

4. Which of the following correctly shows the height of a plastic sunflower plant over a period of four months?

	Height in cm				
	Original height	One month	Two months	Three months	Four months
(1)	150	145	140	135	130
(2)	150	150	150	150	150
(3)	150	155	155	160	155
(4)	150	155	160	165	170

5. Tom kept a few caterpillars and plants in two different set-ups. He placed both set-ups near a window and watered both plants daily.

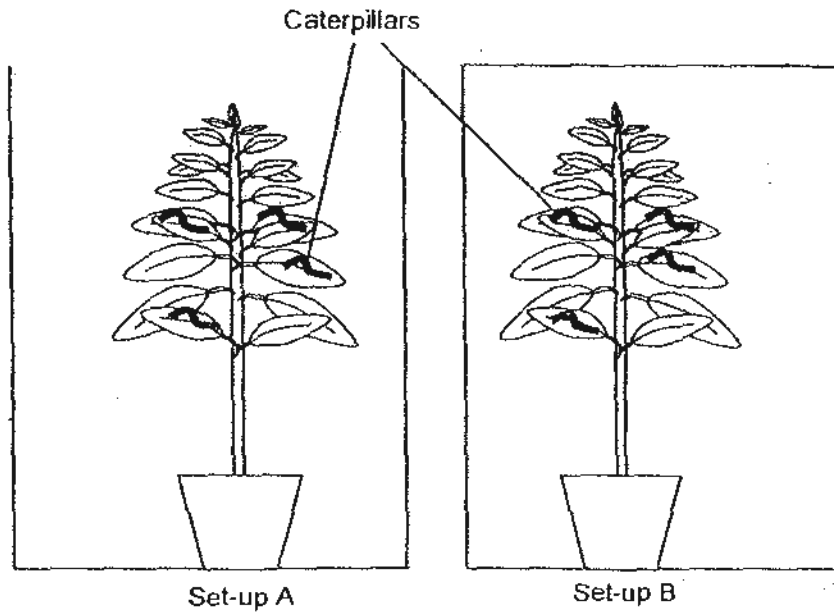

After a week, the caterpillars in Set-up B were dead. Why did the caterpillars in Set-up B die?

- A: There was no food.
 B: There was no water.
 C: There was lack of air.

- (1) A only
 (2) C only
 (3) A and B only
 (4) A, B and C only

6. Study the statements below. Which of them show that living things respond to changes?

A	Meiling screamed when she saw a cockroach.
B	A mother bird fed her nestlings with some worms.
C	Kailing sneezed when she entered a dusty room.
D	The birds flew away quickly when a cat walked towards them.

- (1) A and B only
 (2) C and D only
 (3) A, C and D only
 (4) B, C and D only

7. Study the classification diagram below.

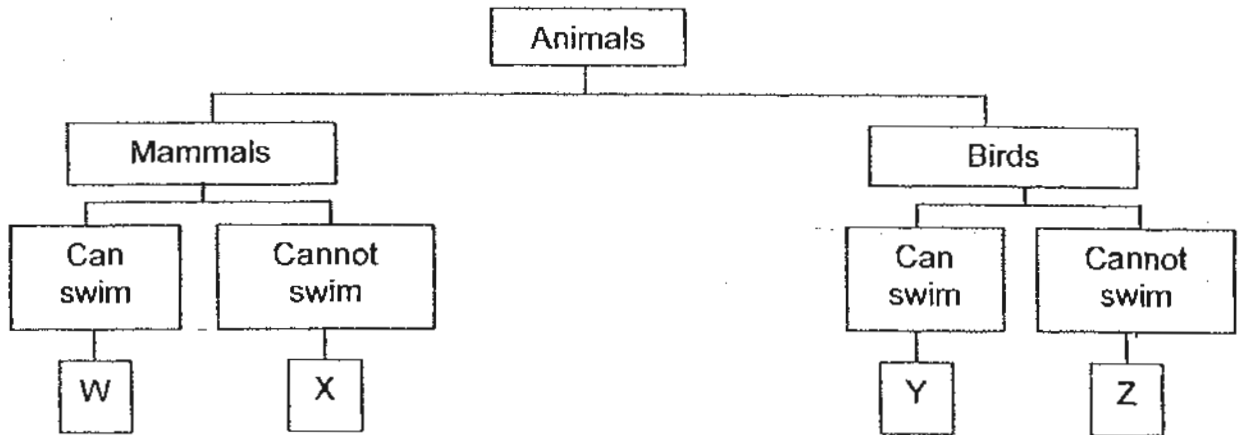

Where should 'penguin' be placed?

- | | |
|-------|-------|
| (1) W | (2) X |
| (3) Y | (4) Z |

8. Read the riddle below.

"This animal is not a bird but it can fly. It has an outer covering of hair on its body."

What is the animal likely to be?

- | | |
|---------------|----------------|
| (1) A bat | (2) An eagle |
| (3) A sparrow | (4) A platypus |

9. Bees, grasshoppers and moth have the following characteristics.

- A : They have wings.
- B : They have 3 body parts.
- C : They have 3 pairs of legs.
- D: They reproduce by laying eggs.

Which characteristics will definitely put them in a group of insects?

- | | |
|---------------------|---------------------|
| (1) A and B only | (2) A, B and C only |
| (3) B, C and D only | (4) A, B, C and D |

10. David wants to classify the animals shown below into 2 groups.

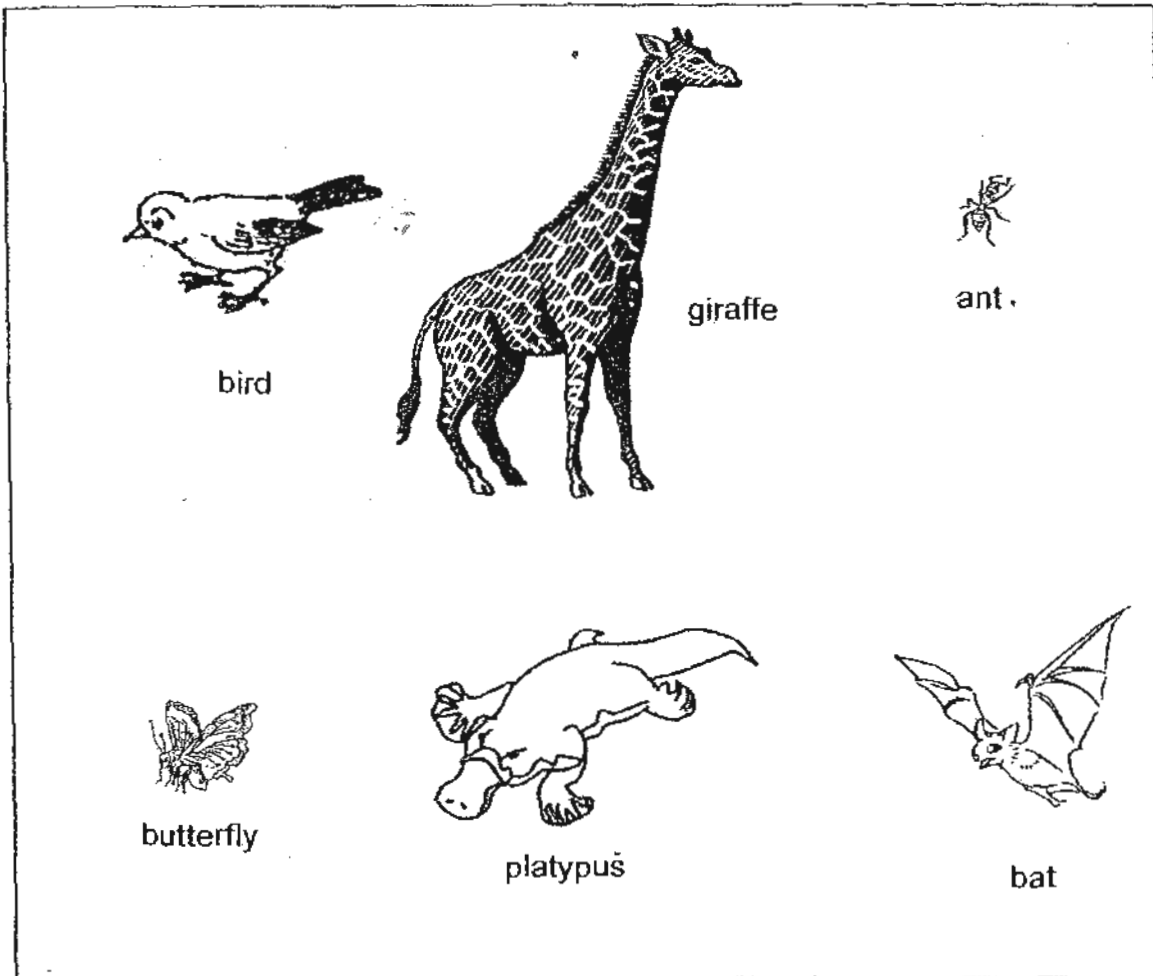

Which of the following headings below are most suitable for the 2 groups if he wants to have 3 animals in each group?

	Group 1	Group 2
(1)	Can fly	Cannot fly
(2)	Lays eggs	Gives birth to young alive
(3)	Has 2 legs only	Has more than 2 legs
(4)	Has hair as outer covering	Has scales as outer covering

13. The table below shows the characteristics of four animals W, X, Y and Z.

Animal	Number of legs			Has wings	Has feelers
	2	4	6		
W	✓			✓	
X		✓			
Y			✓	✓	✓
Z	✓				✓





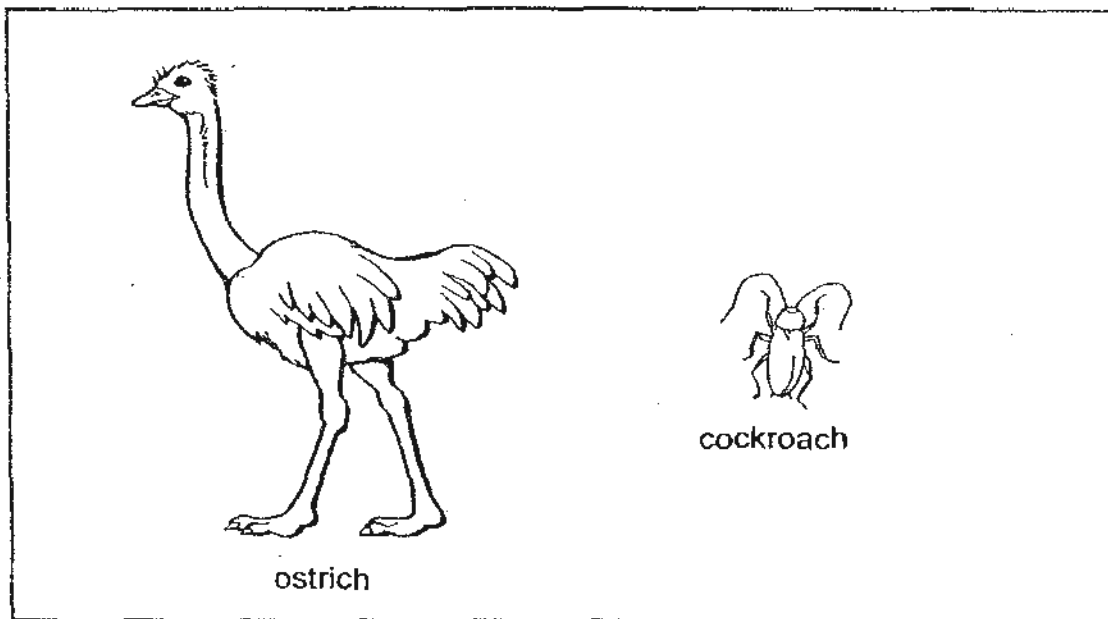



A tick (✓) shows that the animal has the characteristics.

Which animals, W, X, Y or Z could the ostrich and the cockroach be?



	Ostrich	Cockroach
(1)	W	X
(2)	W	Y
(3)	X	Y
(4)	Z	X

14. The animals below have been grouped according to their type of outer coverings.

Group P	Group Q	Group R	Group S
 <p data-bbox="354 586 459 622">cheetah</p>  <p data-bbox="386 855 434 891">cat</p>	 <p data-bbox="651 519 753 555">goldfish</p>  <p data-bbox="657 846 769 882">angelfish</p>	 <p data-bbox="960 564 1024 600">duck</p>  <p data-bbox="986 846 1050 882">eagle</p>	 <p data-bbox="1248 542 1337 577">lobster</p>  <p data-bbox="1264 833 1327 869">crab</p>

Which group would you place the snail in?

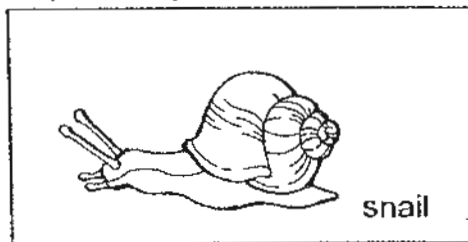

- (1) Group P
- (3) Group R

- (2) Group Q
- (4) Group S

15. Study the flowchart below carefully.

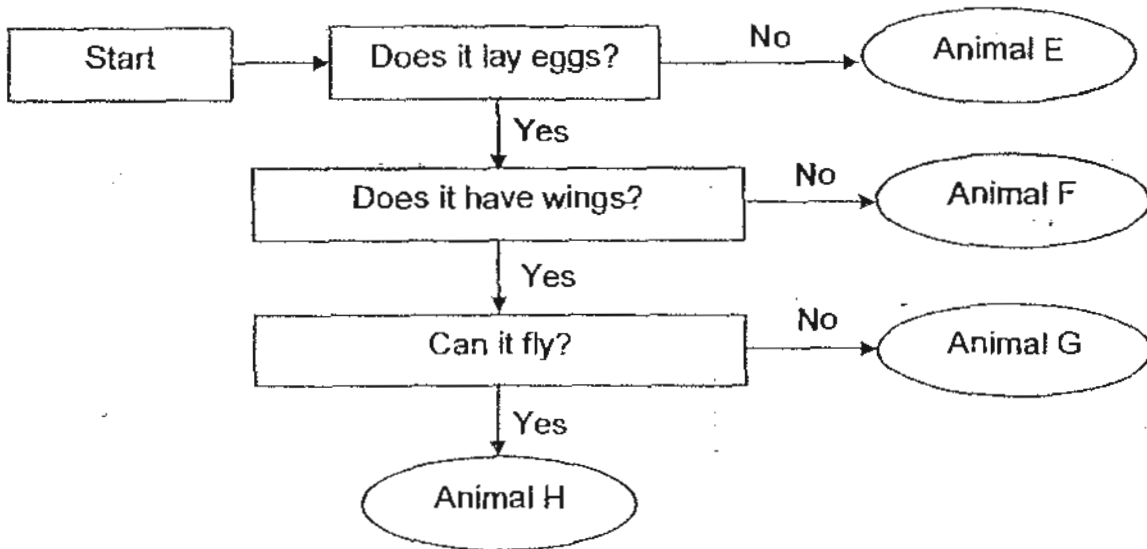

What is/are the similarities between Animal G and Animal H?

- A: Both of them can fly.
- B: Both of them lay eggs.
- C: Both of them have wings.

- | | |
|------------------|----------------|
| (1) A only | (2) B only |
| (3) B and C only | (4) A, B and C |

16. Esther saw an unknown animal in a pond. She kept it in a container and observed it for a few days. She wanted to find out if the animal is a fish. She did the following:

- A: Examine if the animal has feelers.
- B: Examine if the animal has scales.
- C: Find out if the animal swims with its fins.
- D: Find out if the animal breathes with its gills.

Which of the above (A, B, C and D) would definitely help Esther to determine if the animal is a fish?

- | | |
|----------------|----------------|
| (1) A, B and C | (2) A, B and D |
| (3) A, C and D | (4) B, C and D |

17. Bala had two pots of the same plant, A and B. He placed plant A in a box with an opening at the top right-hand corner and plant B in a box with an opening at the bottom right-hand corner. The boxes were placed in an open area and both plants were watered daily. The pictures below show how the plants looked like after one week.

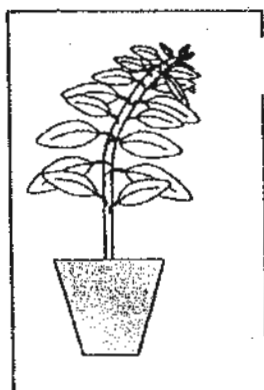

Plant A

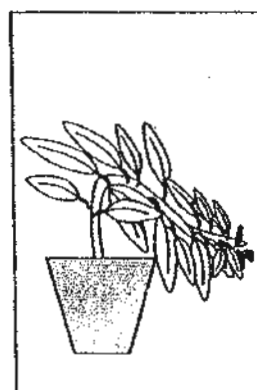

Plant B

Which one of the following statements best describes the observation made by Bala?

- (1) Both plants can move from place to place.
- (2) Plant A grows at a slower rate than Plant B.
- (3) Both plants grow towards the direction of sunlight.
- (4) Plant A has a strong stem while Plant B has a weak stem.

18. Study the picture below.

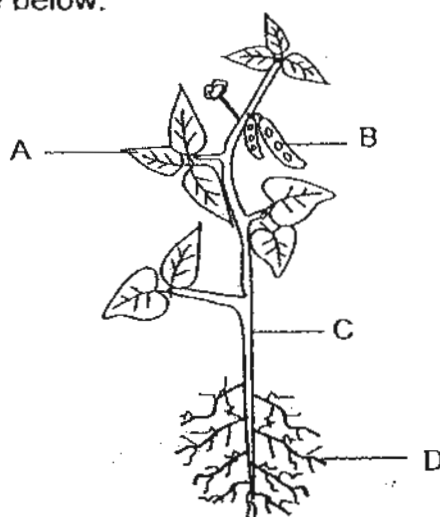

Which one of the following correctly labels the parts of the plant as shown in the diagram?

	A	B	C	D
(1)	Flower	Root	Leaf	Stem
(2)	Leaf	Flower	Stem	Root
(3)	Root	Stem	Flower	Leaf
(4)	Leaf	Fruit	Stem	Root

19. Ai Shan observed the picture of Plant Y as shown below.



Which of the following are possible observations she could make?

- A : It has juicy fruits.
- B : It has a weak stem.
- C : It has oval-shaped leaves.
- D : It needs a support to grow upright.

- (1) A and C only
- (2) B and D only
- (3) A, B and C only
- (4) A, B, C and D

20. Which one of the following plants is a fully-submerged water plant?

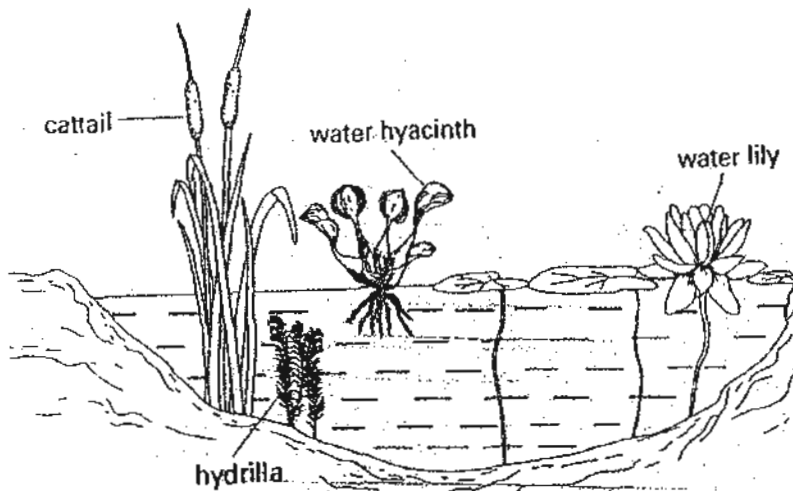

- (1) cattail
- (2) hydrilla
- (3) water hyacinth
- (4) water lily

Study the flowchart below to answer Questions 21 and 22.

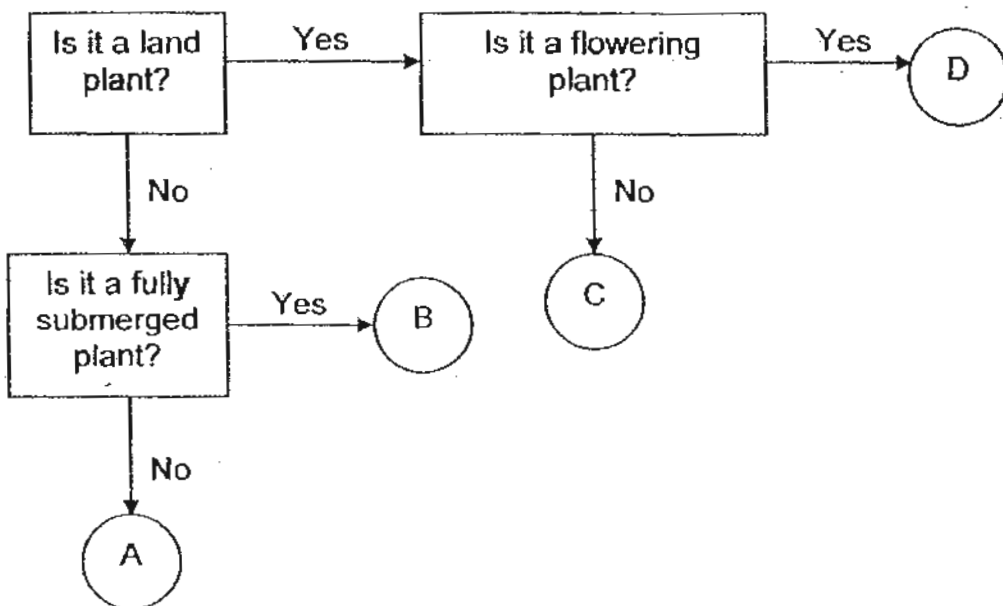

21. Angela came across a plant when she visited the Science Gardens. She found spores on the underside of its leaves. Based on Angela's observation, which of the following group can this plant be placed in?

- (1) A
- (2) B
- (3) C
- (4) D

22. Angela also found other varieties of plants and grouped them according to the flowchart above. Which group has been classified correctly?

	A	B	C
(1)	Ixora	Hydrilla	Moss
(2)	Hydrilla	Cattail	Cucumber
(3)	Rose	Bird nest fern	Cattail
(4)	Cattail	Hydrilla	Ladder fern

25. Study the diagram of bread mould below.

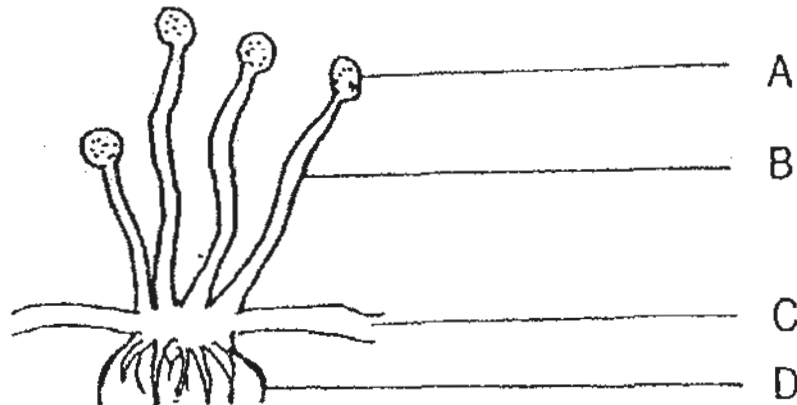

Which part (A, B, C or D) enables the bread mould to reproduce?

- | | |
|-------|-------|
| (1) A | (2) B |
| (3) C | (4) D |

26. Sally left a slice of bread on a plate. After two weeks, she noticed that there were dark patches on the bread.

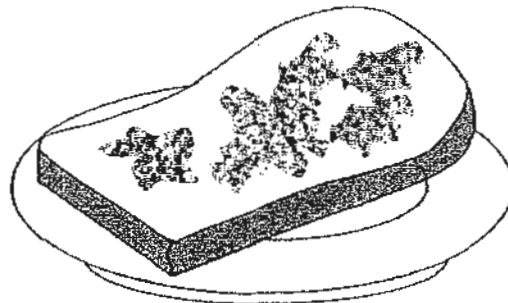

Which of the following statements are true?

- A : The patches seen on the bread can make their own food.
- B : The patches seen on the bread are non-flowering plants.
- C : The patches seen on the bread grows on other living things.
- D : The patches seen on the bread cause the bread to go bad.

- | | |
|---------------------|---------------------|
| (1) A and C only | (2) C and D only |
| (3) A, B and D only | (4) A, C and D only |

27. Danny bought a do-it-yourself mushroom growing kit. He grew the mushroom and recorded the following statements.

- A : Harvested the mushroom.
- B : Watered the kit two times a day.
- C : The mushroom absorbed the nutrients from the kit.
- D : Little mushroom appeared on the surface of the kit.

Which one of the statements above is an observation?

- (1) A
- (2) B
- (3) C
- (4) D

28. Which of the following will not make their own food even when air, water and sunlight are present?

- A : Bracket fungus
- B : Maidenhair fern
- C : Toadstool
- D : Shitake mushroom

- (1) A, B and C only
- (2) A, C and D only
- (3) B, C and D only
- (4) C, D and E only

29. Which of the following can absorb water most readily?

- (1) Rubber
- (2) Ceramic tile
- (3) Plastic sheet
- (4) Tissue paper

30. The flowchart below shows the characteristics of some materials.

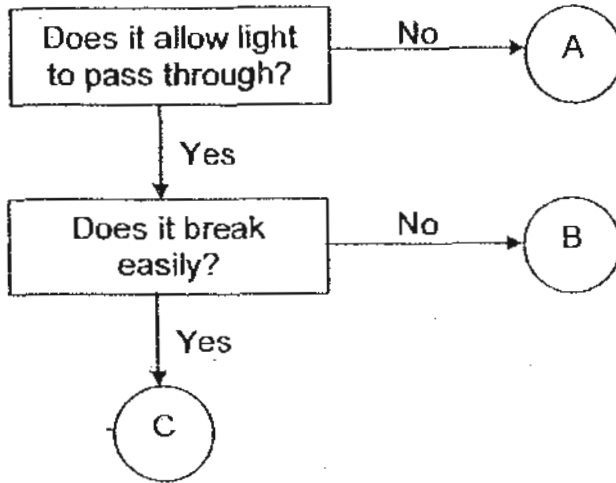

What materials are A, B and C?

	A	B	C
(1)	Wood	Glass	Clear plastic
(2)	Metal	Wood	Glass
(3)	Rubber	Clear plastic	Wood
(4)	Wood	Clear plastic	Glass

☺ END OF PART I ☺



Rosyth School
First Semestral Assessment for 2010
SCIENCE
Primary 3

Name: _____

Total
Marks:



Class: Pr 3-_____ Register No. _____ Duration: 1 h 30 min

Date: 13 May 2010 Parent's Signature: _____

Booklet B

Instructions to Pupils:

1. For questions 31 to 44, write your answers in the spaces given in this Booklet.

* This booklet consists of 12 pages.

This paper is not to be reproduced in part or whole without the permission of the Principal.

PART II (40 MARKS)

For questions 31 to 44, write your answers in this booklet.

31. The following statements are about living things. (2m)

Write "T" if the statement is true and "F" if the statement is false.

- (a) All living things need air, food and water to survive. ()
- (b) Animals that live in water, such as fish, do not need air to survive. ()
- (c) Plants cannot respond to changes around them. ()
- (d) A diver can stay underwater by breathing from an oxygen tank. ()

32. Classify the following things into the correct groups. (3m)

cow boat	helicopter snake	plant kite
-------------	---------------------	---------------

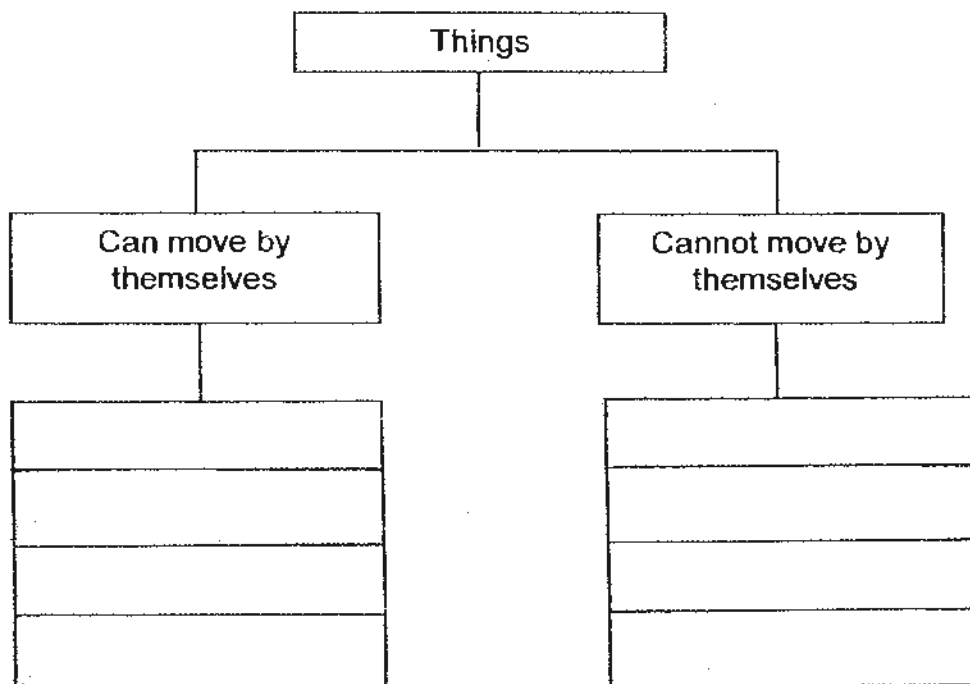

33. Study the pictures below carefully.

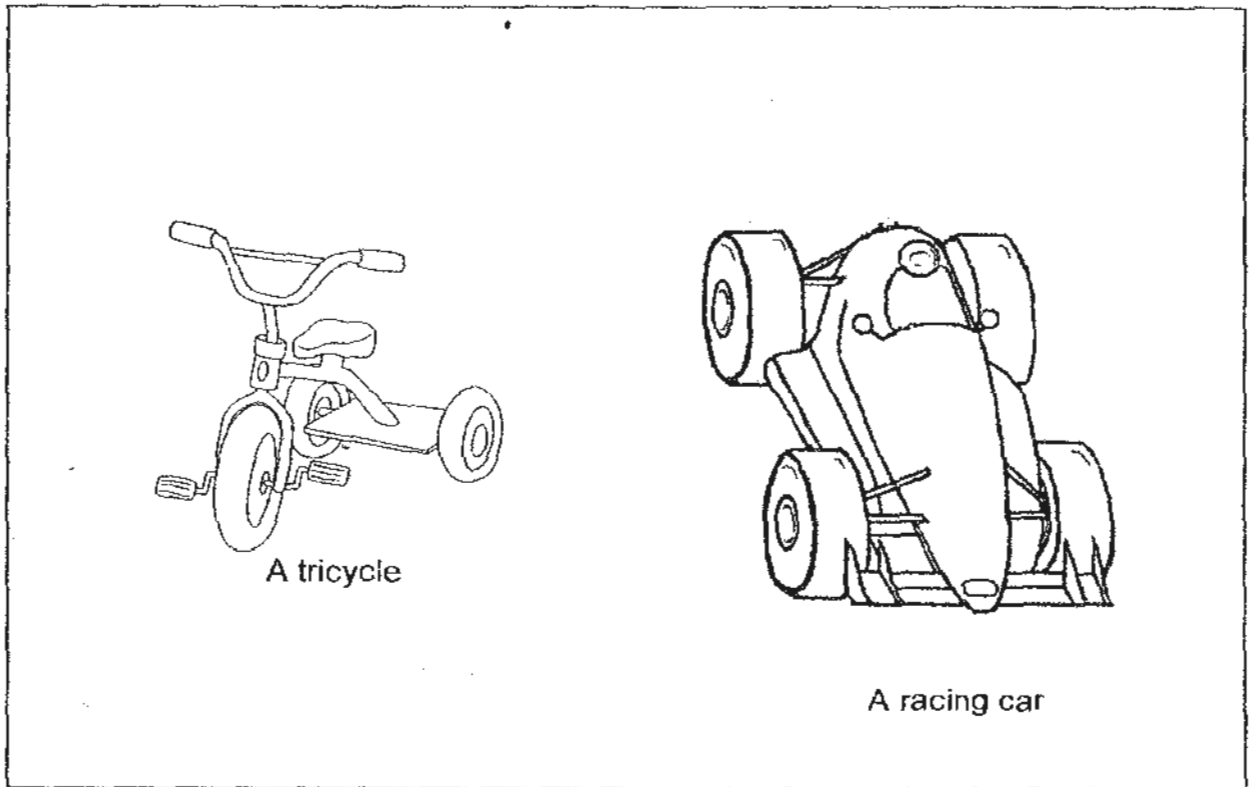

Based on only what you see from the pictures, state one similarity and difference between the tricycle and the racing car. (2m)
(Do **not** compare their shapes or sizes)

(a) Similarity

(b) Difference

34. Kelly bought a pet bird and placed it in a cage.

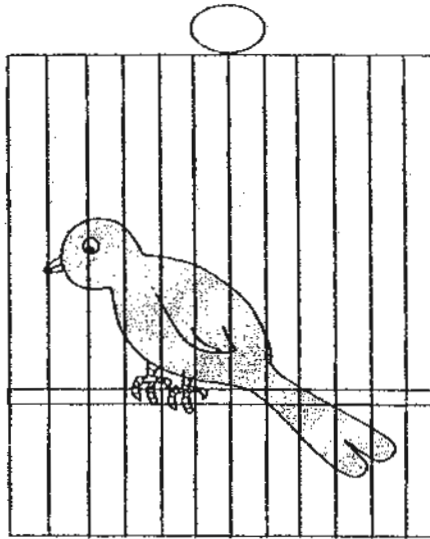

- (a) What must Kelly put into the cage to ensure that the bird stays alive? (1m)

- (b) When Kelly put her hands into the cage, the bird flew to the opposite side of the cage. What characteristic of living things was the bird showing? (1m)

35. John saw an animal, W, as shown below.

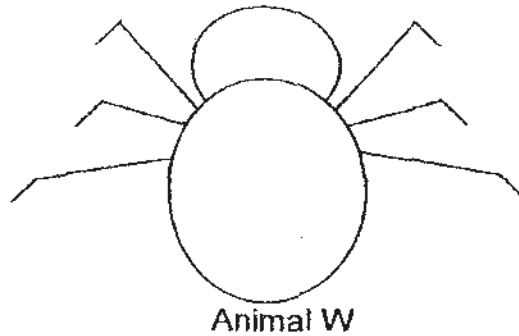

He wanted to classify Animal W in the classification diagram below.

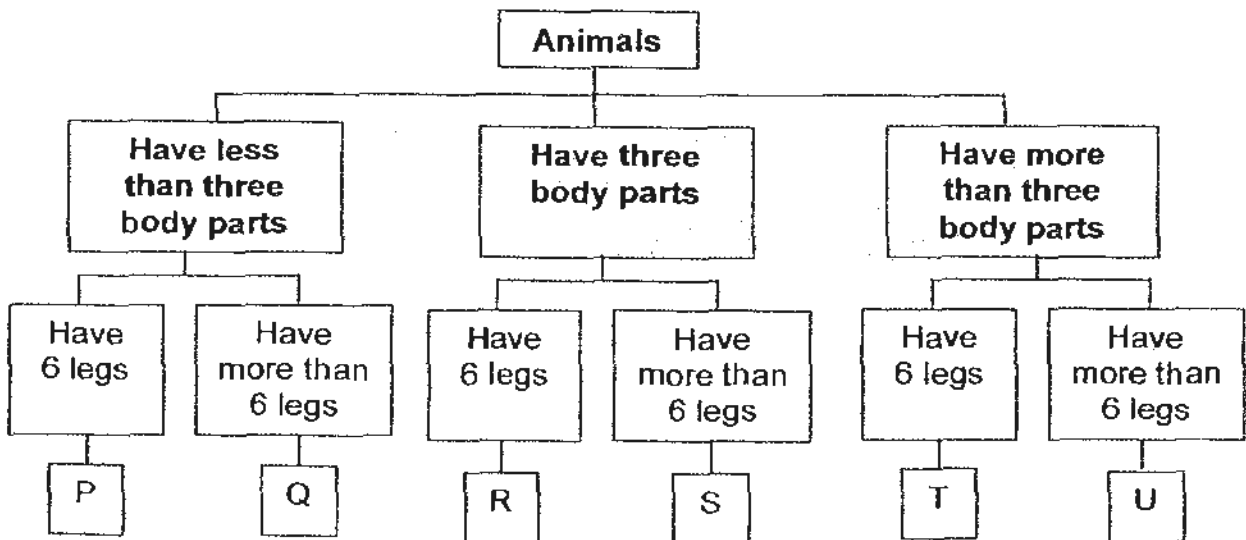

(a) Which letter (P, Q, R, S, T or U) in the classification diagram best represents Animal W? (1m)

(b) Is Animal W an insect? Explain your reason. (1m)

36. Tim caught 2 bees from the garden and put them in a glass tank. He also placed a fern in the tank. Then, he covered the tank with a sheet of plastic. His mother reminded him to make holes on the plastic sheet.

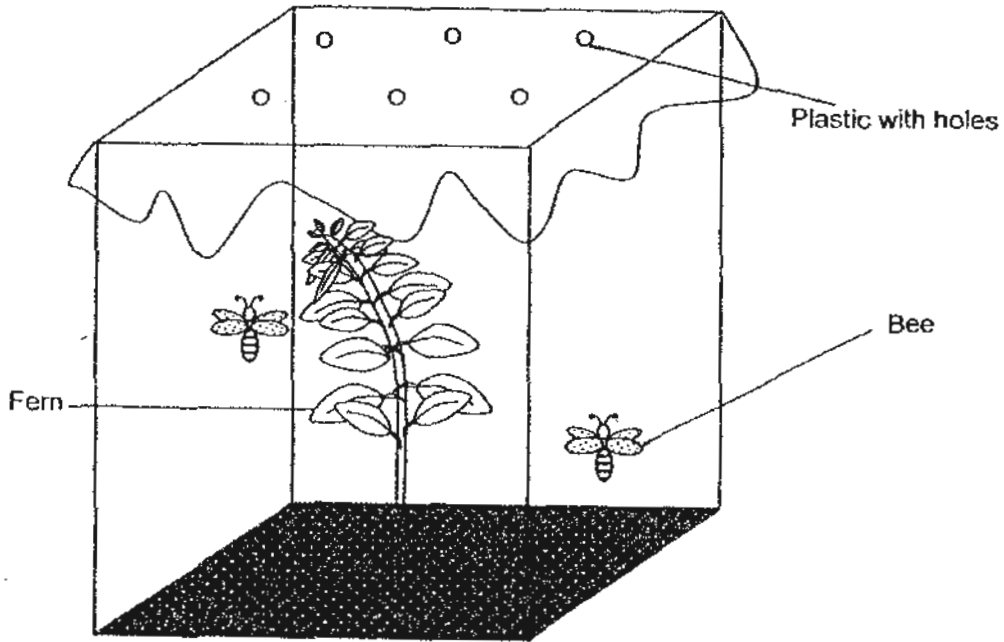

- (a) Why must Tim make holes on the plastic sheet? (1m)

- (b) What may happen to the bees after two weeks? (1m)

- (c) Explain your answer in (b) (1m)

37. Study the classification diagram below.

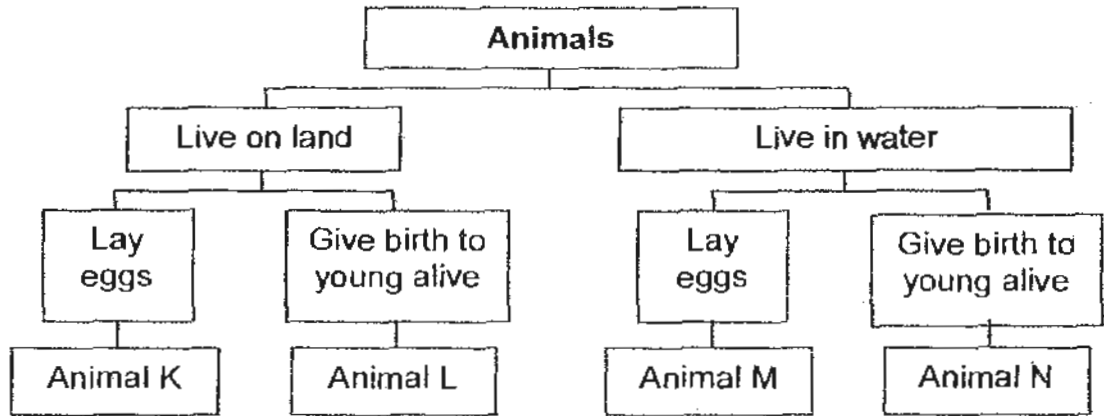

(a) Using only the information from the classification diagram above, describe the characteristics of Animal K. (1m)

(b) Write the letter (K, L, M, N) that best represents the following animals in the given boxes. (2m)

(i) Lion : Animal

(ii) Goldfish : Animal

38. Study the flowchart below.

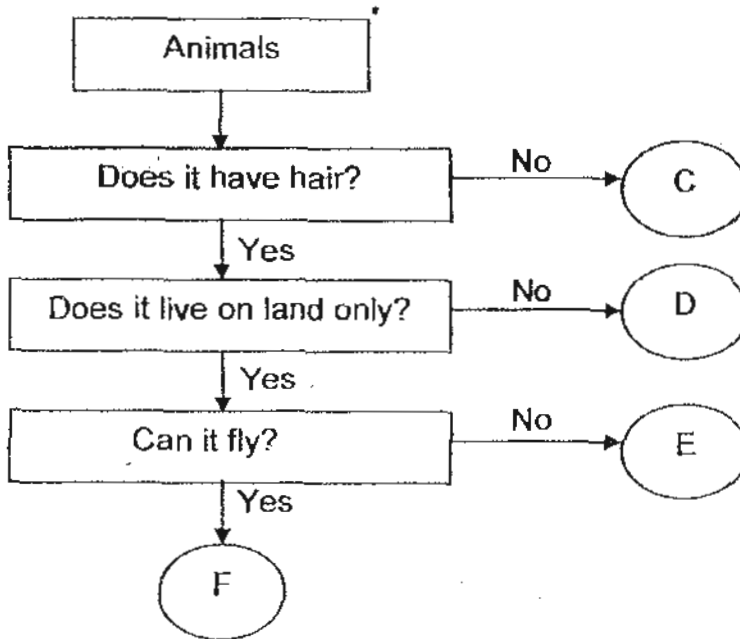

(a) Which of the above letters best represent the following animals? (2m)

(i) Parrot: _____

(ii) Kangaroo: _____

(b) From the flowchart above, state the similarities between Animal E and Animal F. (1m)

(c) Rachael said that 'D' must be a mammal. Do you agree with Rachel? Support your answer with a reason. (1m)

39. The diagram below shows a picture of a flowering plant, Plant Q.



Plant Q

(a) Describe the characteristics of the leaf of Plant Q. (1m)

(b) Sam said that the hibiscus plant can be placed in the same group as Plant Q.

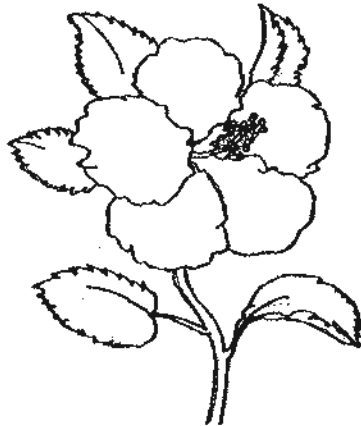

Hibiscus

Do you agree with Sam? Support your answer with a reason. (1m)

40. Samy found a variety of leaves during his walk at Punggol Park. He labelled them as shown below.



Leaf M



Leaf N



Leaf O



Leaf P

(a) Classify all the leaves above into two groups. Write the letters in the table below. (2m)

Group A	Group B

(b) Give a suitable heading for each group. (1m)

(i) Group A : _____

(ii) Group B : _____

Samy also found Leaf X (shown below) during another trip to the park.



Leaf X

(c) In which group (A or B) would you place Leaf X? Give a reason for your answer. (1m)

41. Study the classification chart below.

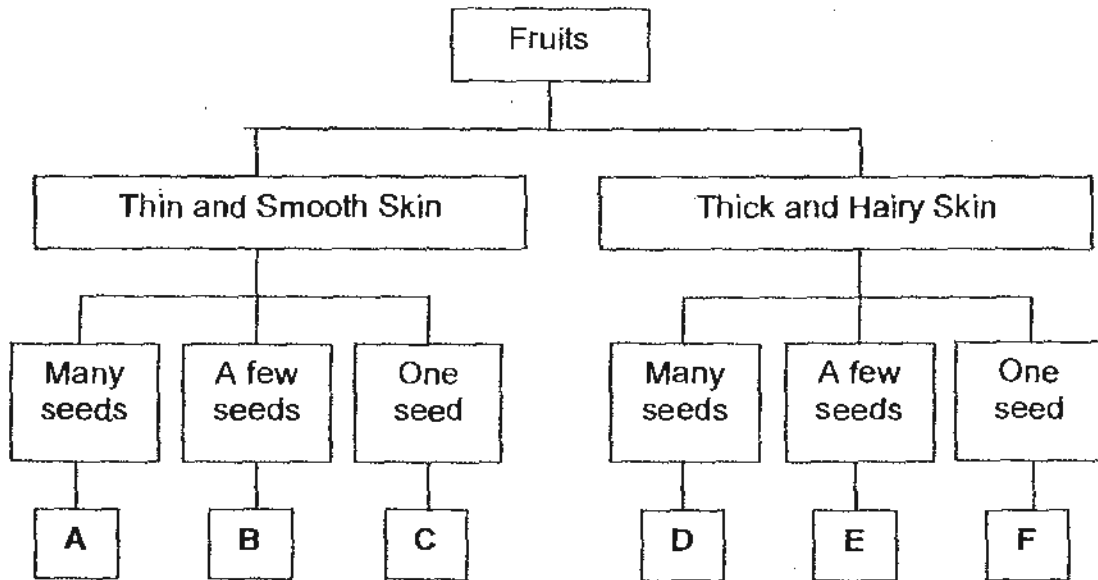

(a) Describe the characteristics of Fruit A. (1m)

(b) How is Fruit C different from Fruit F? (1m)

(c) How is Fruit B similar to Fruit E? (1m)

(d) Write the letter that represents each of the fruit in the boxes below : (2m)



Rambutan



Papaya

42. The picture below shows a mushroom.

(a) Identify the parts marked 'R' and 'S'. (2m)

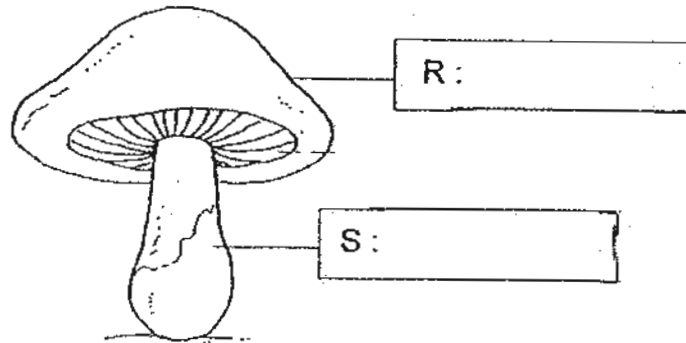

(b) Where are the spores found? (1m)

43. Look at the diagram below carefully.

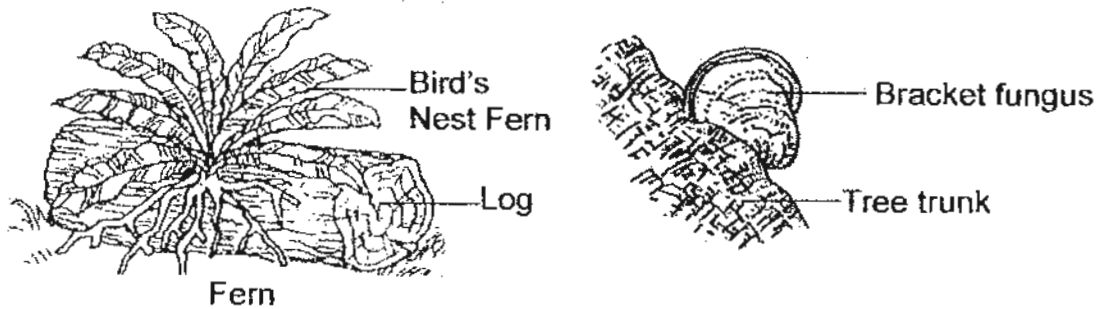

(a) State one difference between how the Bird's Nest Fern and bracket fungus obtain their food. (1m)

(b) State one similarity between how the Bird's Nest Fern and bracket fungus reproduce. (1m)

44. The diagram below shows a motorcycle.

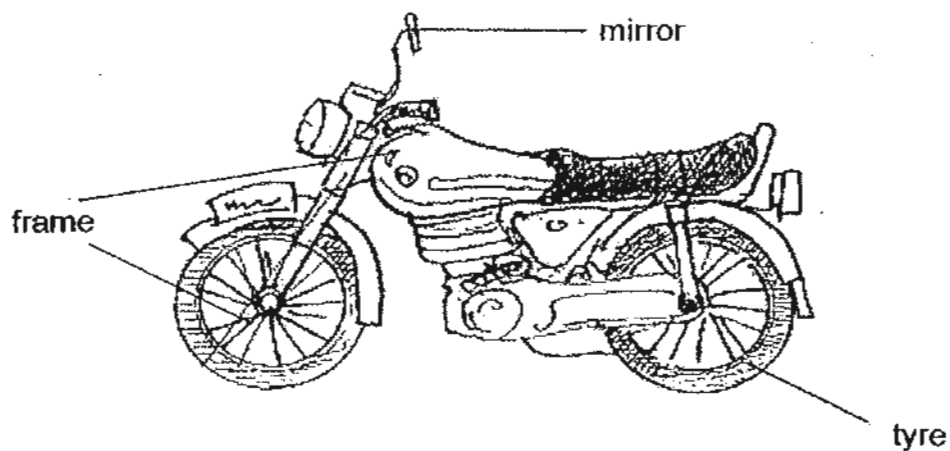

Name the material that is most suitable to make each of the parts of the motorcycle.
(3m)

	Object	Property of material	Type of material
(a)	Mirror	Breaks easily	
(b)	Tyre	Soft and flexible	
(c)	Frame	Hard and strong	

ANSWER SHEET

EXAM PAPER 2010

SCHOOL : ROSYTH PRIMARY
SUBJECT : PRIMARY 3 SCIENCE

TERM : SA1

Q1	Q2	Q3	Q4	Q5	Q6	Q7	Q8	Q9	Q10	Q11	Q12	Q13	Q14	Q15	Q16	Q17
2	2	4	2	2	3	3	1	3	1	3	1	2	4	3	4	3

Q18	Q19	Q20	Q21	Q22	Q23	Q24	Q25	Q26	Q27	Q28	Q29	Q30
4	2	2	3	4	3	2	1	2	4	2	4	4

31)a)T b)F c)F d)T

32)can move by themselves

Cow
Plant
Snake

Cannot move by themselves

boat
helicopter
kite

33)a)They both have wheels.

b)The racing car have four wheels but the tricycle have three wheels.

34)a)Kelly have to put water and food to ensure that the bird stay alive.

b)Living things respond to changes.

35)a)P. b)No, Insects have three body parts.

36)a)For the Bees to breathe. b)They will die.

c)It needs water and food.

37)a)It lives on land and it lay eggs. b)i)L ii)M

38)a)i)C ii)E b)They have hair and live on land.

c)Yes, They have hair.

39)a)The leaf is over in shape and has a jagged edge.

b)Yes, as the hibiscus has jagged edge.

40)a)Group A: P, M Group B: N, O

b)i)jagged edge ii)entire edge c)B, It has entire edge.

41)a)It has thin and have smooth skin.

b)Fruit C have thin a and smooth skin but the Fruit F has a thick and hairy skin.

c)They have a few seeds.

d)F, A

42)a)R: cap S: stalk b)under the gills.

43)a)Bird's hest fern makes its own food but bracket fungus feeds on the tree trunk.

b)Spores.

44)a)glass b)rubber c)metal