



RED SWASTIKA SCHOOL

# RED SWASTIKA SCHOOL

## 2010 SEMESTRAL ASSESSMENT 2

### SCIENCE PRIMARY 3

Name : \_\_\_\_\_ (     )

Class : Primary 3/ \_\_\_\_\_

Date : 28 October 2010

### BOOKLET A

Total time for Booklets A & B: 1h 30 min

Booklet A: 30 questions (60 marks)

Note:

1. Do not open the booklet until you are told to do so.
2. Read carefully the instructions given at the beginning of each part of the booklet.
3. Do not waste time. If the question is too difficult for you, go on to the next question.
4. Check your answers thoroughly and make sure you attempt every question.
5. In this booklet, you should have the following:
  - a. Page 1 to Page 18
  - b. Questions 1 to 30

**Section A**

For Questions 1 to 30, choose the most suitable answer and shade its number in the OAS provided.

1 Two groups of things are classified based on the following characteristics below.

<i>Plants</i> Group P	<i>Animals</i> Group Q
<ul style="list-style-type: none"> <li>• Has roots to take in water</li> <li>• Does not move from place to place</li> <li>• Usually responds slowly to changes</li> </ul>	<ul style="list-style-type: none"> <li>• No roots to take in water</li> <li>• Moves from place to place</li> <li>• Usually responds quickly to changes</li> </ul>

Which one of the following sets of headings is suitable for Group P and Q?

(1)	Group P Plants	Group Q Animals
(2)	Non-living things	Living things
(3)	Organisms that live in water	Organisms that live on land
(4)	Animals that breathe with lungs	Animals that breathe with gills

2 Fred and his friends saw a green plant growing on a rock in the school ecogarden. His friend guessed that it was a non-flowering plant.

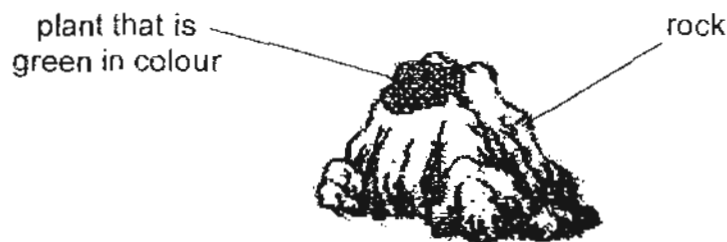

To confirm his friend's guess that it was a non-flowering plant, Fred could find out whether the plant had \_\_\_\_\_.

- (1) stems
- (2) leaves
- (3) spore bags
- (4) roots

3 Study the two plants below.



Morning glory



Rose plant

Based on the pictures above, which of the following statements about the plants are true?

- Both have weak stems.
- Both have leaves with veins.
- Both have oval-shaped leaves.
- Both have flowers that grow in bunches.

4 Jean collected four leaves from the Botanic Gardens as shown below.



Based on observation of the pictures, how can you help her to classify the leaves?

- By the texture
- By the leaf edge
- By the vein pattern.
- By the number of leaf blades.

5 Study the flowchart below which shows the characteristics of two animals, A and B.

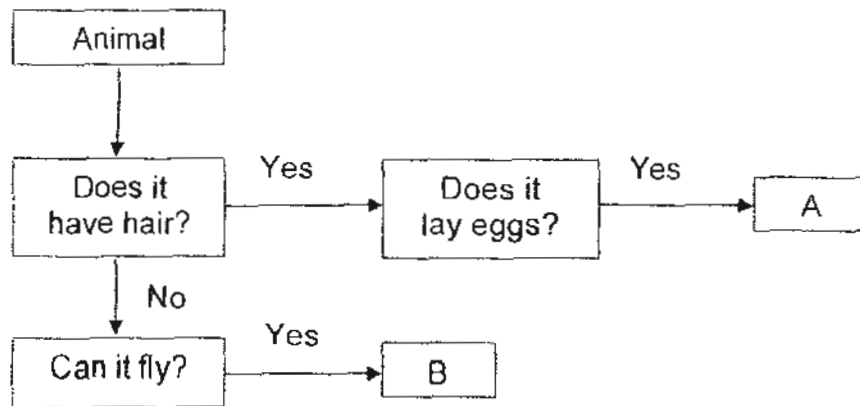

Which animals are best represented by A and B?

	Animal A	Animal B
<del>(1)</del>	whale	ostrich
<del>(2)</del>	emu	seagull
<del>(3)</del>	spiny anteater	penguin
<del>(4)</del>	platypus	parrot

6 Roy set up the following experiments to investigate on the growth of mould. In which one of the following experiments would he most likely find mould after three days?

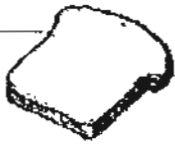
~~(1)~~ Untoasted bread  Kept in the refrigerator at 4°C

~~(2)~~ Untoasted bread  Kept in the open at room temperature

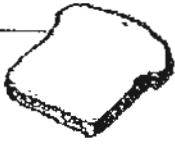
~~(3)~~ Toasted bread  Kept in the refrigerator at 4°C

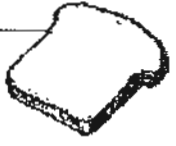
~~(4)~~ Toasted bread  Kept in the open at room temperature

7 Study the classification chart of living things below.

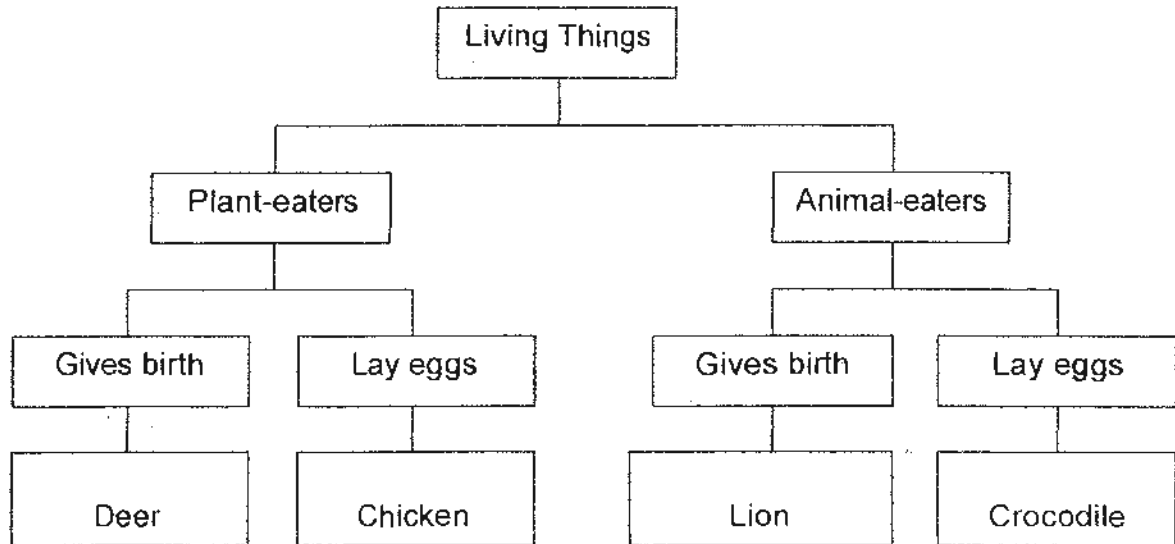

Which animal is wrongly classified?

- (1) Deer
- (2) Chicken
- (3) Lion
- (4) Crocodile

8 What is the main function of the stem of a plant?

- (1) To hold the plant upright.
- (2) To absorb nutrients from the ground.
- (3) To attract other animals.
- (4) To make food for the plant.

9 Which of the following is found in the tiny tubes inside the stem of a plant?

- A: Water
- B: Food
- C: Mineral salts

- (1) A only
- (2) A and B only
- (3) B and C only
- (4) A, B and C

10 Siti put a plant in a beaker of red-coloured water as shown below.

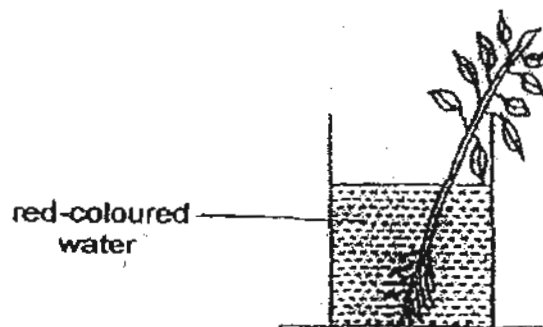

The next day, she cut a cross-section of the stem and saw red-coloured structures in the cross-section of the stem.

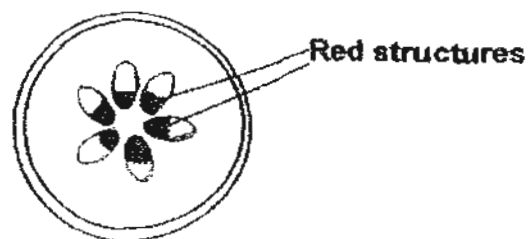

From the experiment above, Siti concluded that the red structures

- (1) hold the plant to the ground
- (2) absorb water and mineral salts
- (3) transport food to all parts of the plant
- (4) transport water to all parts of the plant

11 Study the flow charts below carefully. Which one correctly shows the direction of the flow of water in plants?

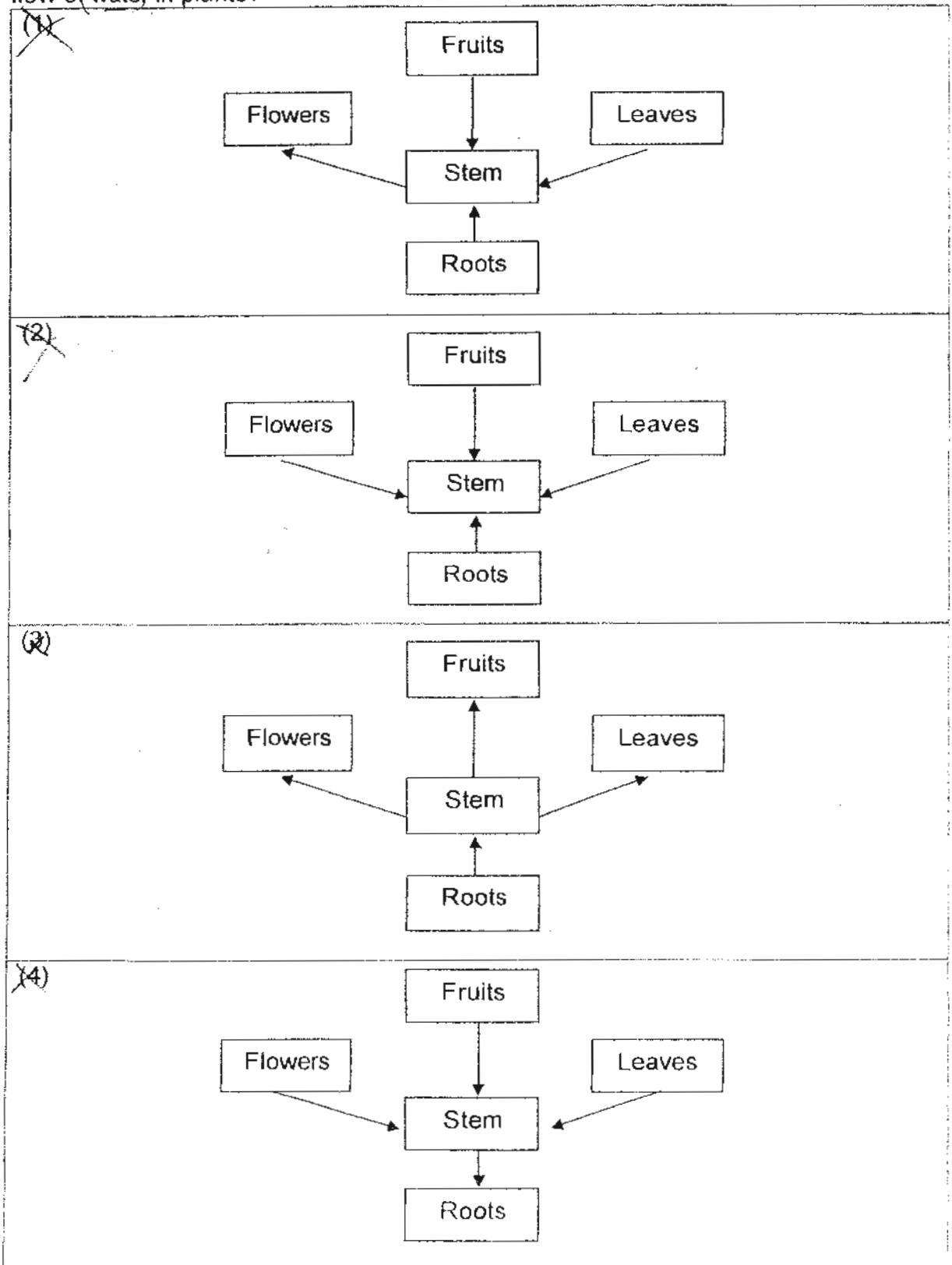

- 12 Ramesh conducted an experiment on two similar plants, X and Y, and recorded his observation in the table below.

Plant	Number of leaves on the plant	Amount of water in the container at the start of the experiment	Amount of water in the container at the end of the experiment
X	25	250 ml	163 ml
Y	39	250 ml	148 ml

Based on the data above, what can Ramesh observe at the end of the experiment?

- (1) Plant Y has less water than Plant X.
- (2) Plant X has less water than Plant Y.
- (3) Plant Y has less leaves than Plant X.
- (4) Plant X has more leaves than Plant Y.

- 13 The windpipe is part of the \_\_\_\_\_ system.

- (1) muscular
- (2) digestive
- (3) respiratory
- (4) circulatory

- 14 In which of the following parts is digestive juices added?

- (1) Anus
- (2) Gullet
- (3) Small intestine
- (4) Large intestine

- 15 Which of the following does not take place in the mouth?

- (1) The food is shaped into balls.
- (2) The food is churned.
- (3) The food is mixed with saliva.
- (4) The food is cut and sliced into small pieces.

16 The diagram below shows a system in the human body.

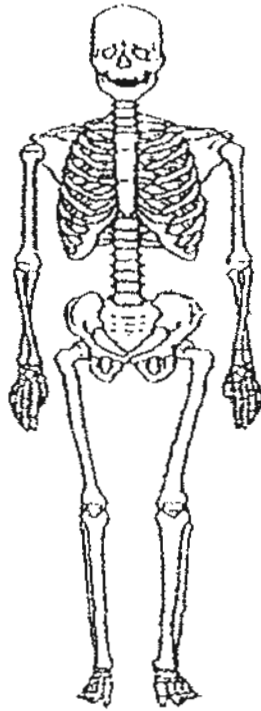

What is the function of this system?

- (1) Allows exchange of gases
- (2) Supports and maintains the body shape
- (3) Digests food into simple substances
- (4) Carries oxygen around the body

17 Digested food is absorbed into the body from the \_\_\_\_\_.

- (1) anus
- (2) stomach
- (3) large intestine
- (4) small intestine

18 The diagram below describes materials A, B, C and D.

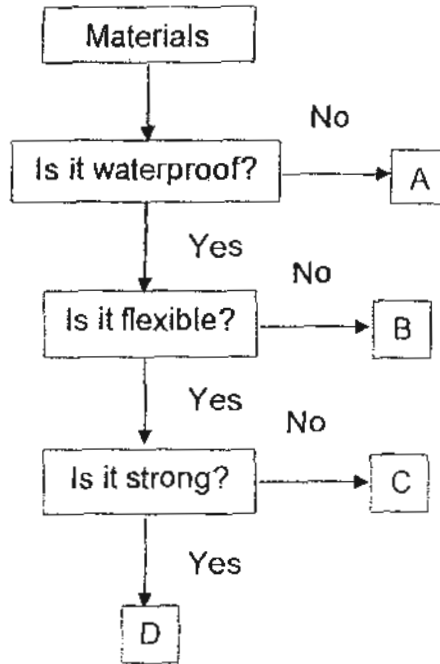

Which one of the following is the most suitable material for making the gloves for firemen?

- A
- B
- C
- D

- 19 Jeff compared the degree of hardness of three materials, P, Q and R, by using one material to scratch the other two. He observed how deep the scratches were and recorded his results in the table below.

Material used	Scratches on P	Scratches on Q	Scratches on R
P	---	Deep	No
Q	No	----	No
R	Slight	Deep	----

How should he arrange the materials from the hardest to the least hard?

- (1) Q, P, R  
 (2) P, R, Q  
 (3) R, P, Q  
 (4) R, Q, P

- 20 Which of the following objects can be attracted by a magnet?

(1)



Tennis ball

(2)

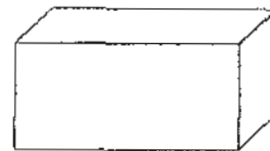

Eraser

(3)



Safety pin

(4)



Matchstick

- 21 Otto wanted to test the strength of three different materials, V, W and X. He dropped a 1 kg weight from a fixed height on each of the materials as shown in the diagram below.

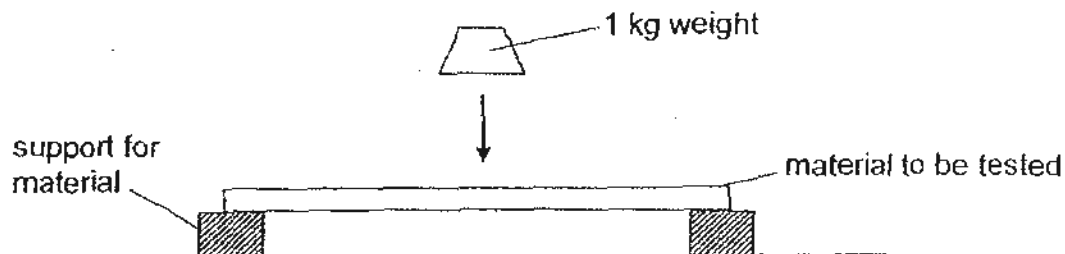

He recorded the number of times the weight was dropped before the materials broke into two pieces in the table below.

Material	Number of times the weight was dropped before the material broke into two pieces
V	30
W	20
X	50

Based on table above, Otto can conclude that \_\_\_\_\_

- (1) Material W is the weakest.
- (2) Material V is the strongest.
- (3) Material X is weaker than Material
- (4) Material X broke into two pieces first.

- 22 Mrs Rahman tied a U-shaped magnet above a paper clip as shown below. When she placed Sheet S between the magnet and the clip, the paper clip remained in the position as shown below.

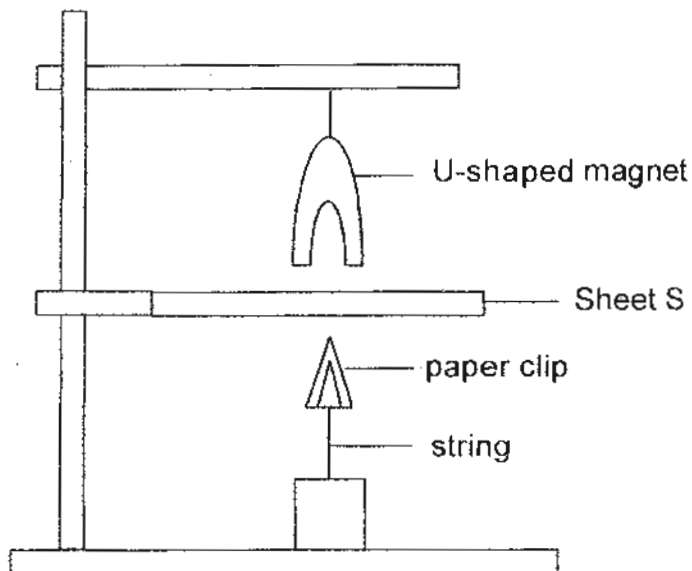

What material could Sheet S be made of?

- (1) Glass
- (2) Iron
- (3) Copper
- (4) Steel

- 23 When Mr Bala placed two button magnets together as shown, he observed that the magnets became 'stuck' to each other. What does this show?

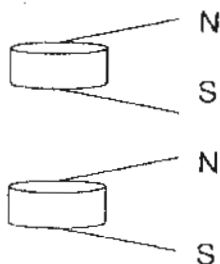

- (1) Like poles of the button magnets repel.
- (2) Like poles of the button magnets attract.
- (3) Unlike poles of the button magnets repel.
- (4) Unlike poles of the button magnets attract.

24 A magnet is suspended freely in the air by a piece of string shown in the diagram below. It is spun for a while and comes to rest. In which position would it come to rest?

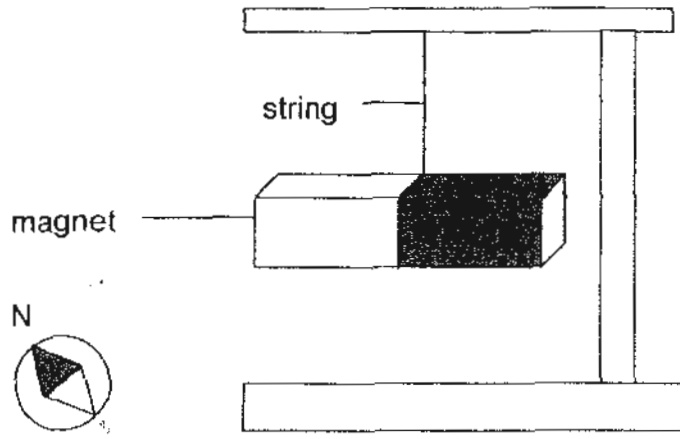

<p>(1)</p>	<p>(2)</p>
<p>(3)</p>	<p>(4)</p>

- 25 Tiffany placed a bar magnet near Object X as shown below. Then she repeated the experiment with Object Y.

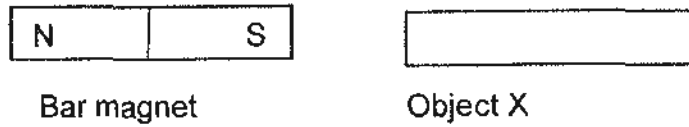

She recorded her observations in the table below.

Object	Observation
X	No reaction
Y	Attracted to one end of the magnet and repelled the other end of the magnet

Based on her observations, which of the following statement is true?

- (1) Object X is a magnet.
- (2) Object X is not a magnet.
- (3) Object Y is not a magnet.
- (4) Object Y is not made of magnetic material.

- 26 Nick used similar steel nails, batteries and electrical wires and prepared the four set-ups as shown below.

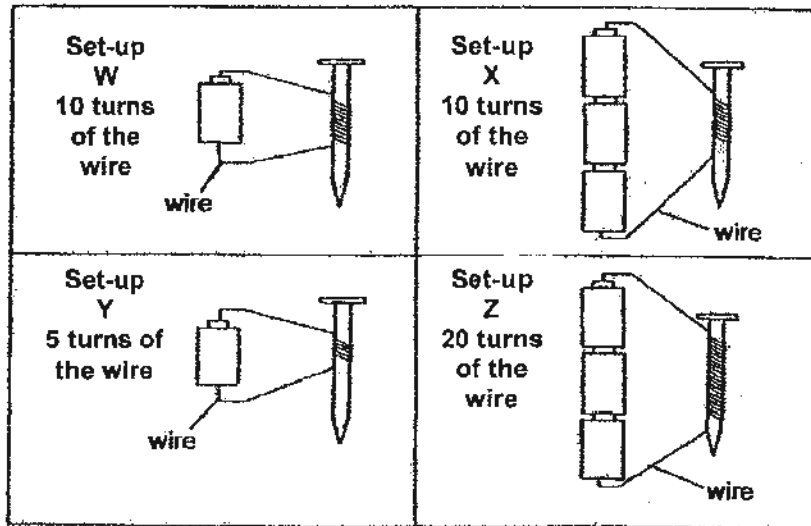

Which set-up will have the strongest electromagnet?

- W
- X
- Y
- Z

27 Mr Tan magnetised a steel rod using the 'stroke' method as shown below.

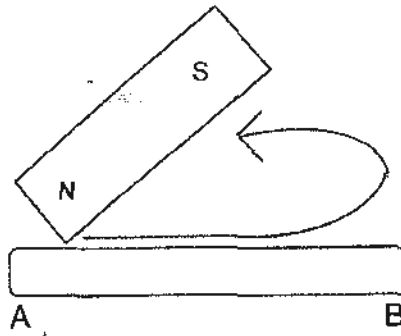

What would poles A and B of the steel rod be?

	A	B
<del>(1)</del>	North	South
<del>(2)</del>	North	North
<del>(3)</del>	South	North
<del>(4)</del>	South	South

28 Hilary held a U-shaped magnet over some pins. She counted the number of pins attracted by Part A, B and C of the magnet.

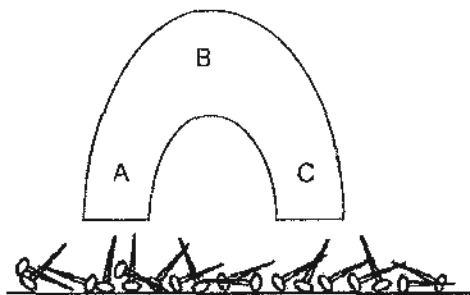

Which of the following observations is possible?

	No of pins attracted		
	A	B	C
<del>(1)</del>	10	11	10
<del>(2)</del>	10	1	11
<del>(3)</del>	1	11	1
<del>(4)</del>	11	10	1

29 In which of the following set-ups will the most number of pins be attracted by Magnet A?

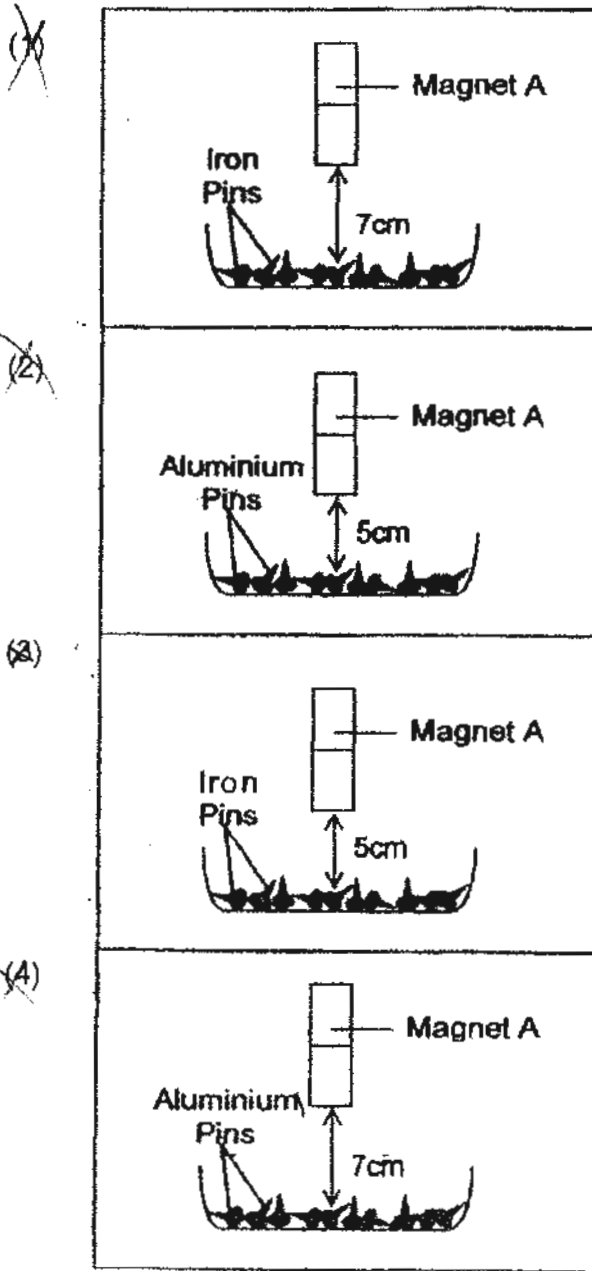

- 30 The diagram below shows three discs, each with a hole at its centre. Two of the discs are magnets and one is made of rubber. All three discs can be slotted through the wooden stand.

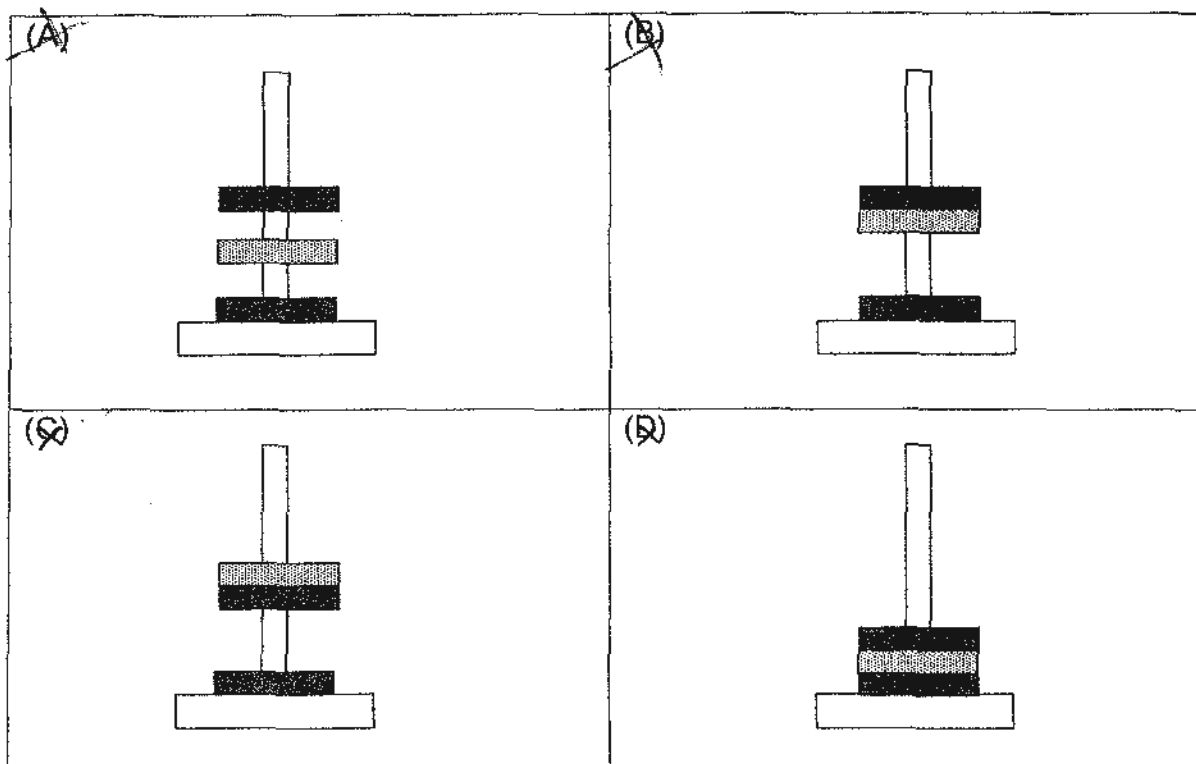
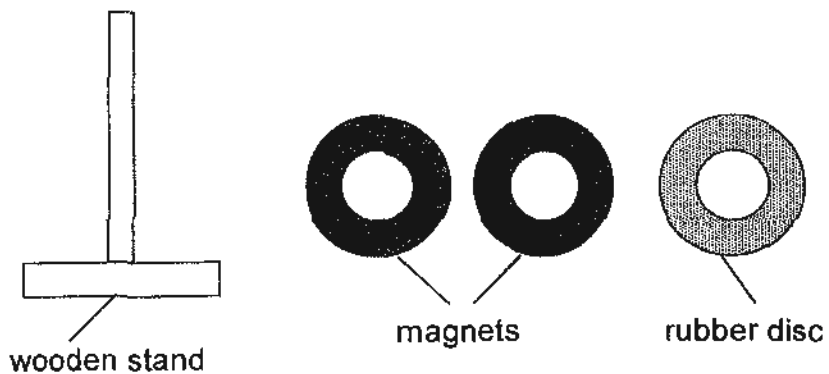

Which one of the above disc arrangements are possible?

- (1) A and B only
- (2) A and D only
- (3) B and C only
- (4) C and D only

**\*\* End of Section A \*\***



RED SWASTIKA SCHOOL

# RED SWASTIKA SCHOOL

## 2010 SEMESTRAL ASSESSMENT 2 SCIENCE PRIMARY 3

Name : \_\_\_\_\_ (      )

Class : Primary 3/ \_\_\_\_\_

Date : 28 October 2010

### BOOKLET B

14 Questions

40 Marks

In this booklet, you should have the following:

- a. Page 19 to Page 30
- b. Questions 31 to 44

#### MARKS

	OBTAINED	POSSIBLE
BOOKLET A		60
BOOKLET B		40
TOTAL		100

Parent's Signature : \_\_\_\_\_

**Section B**

**Answer all the questions in the spaces provided.**

**31** Isabelle classified some plants in the chart below.

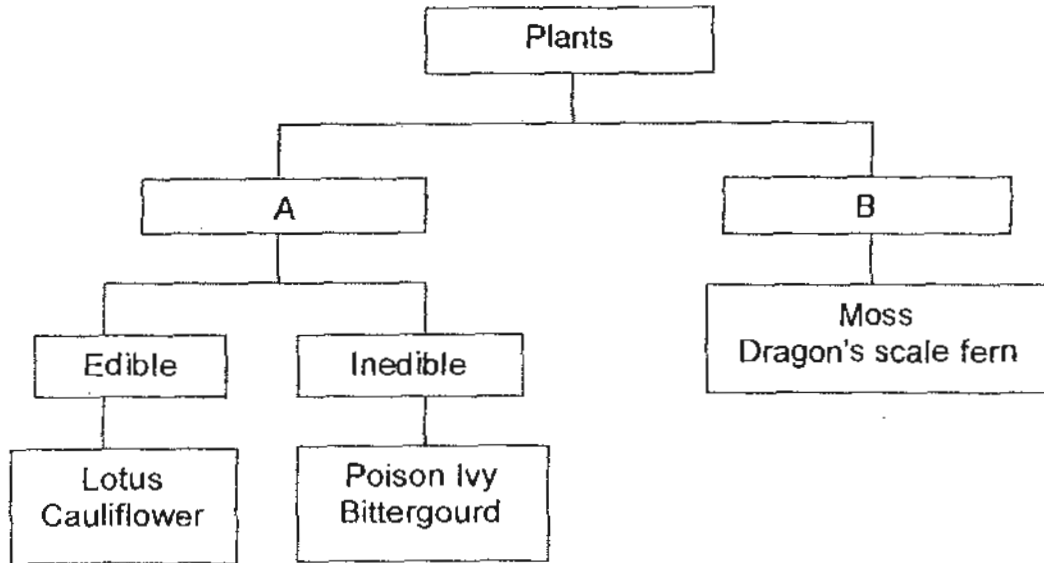

a) What headings do you think Isabelle has given for group A and B? (1m)

A: \_\_\_\_\_

B: \_\_\_\_\_

b) Mr Kim, Isabelle's Science teacher, told her that she has classified one of the plants wrongly.

What is this plant? Explain your answer. (2m)

---

---

- 32 Leonard set up an experiment to compare the growth of Seeds X and Y. He placed the set-ups in his garden and observed them for seven days. He added the same amount of water to both set-ups daily.

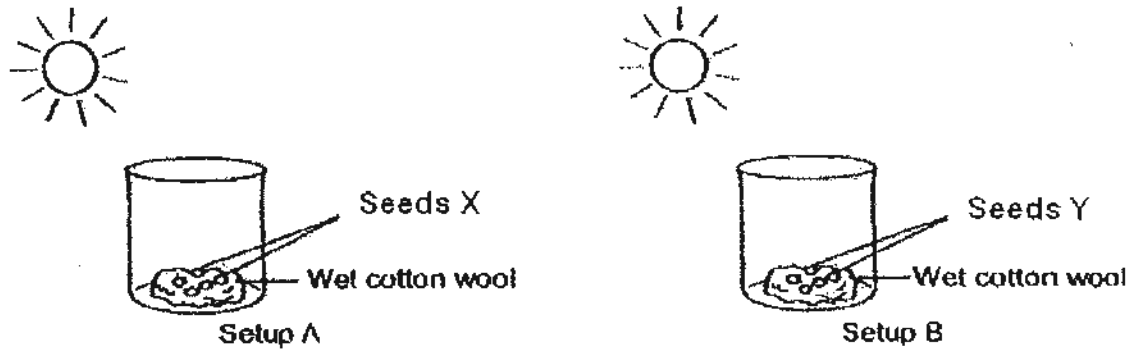

He observed and recorded the changes in the height of the seedlings over the period in the table below.

Seed	Height of the Seedlings (cm)		
	Day 1	Day 3	Day 7
X	1	5	11
Y	0	3	7

- a) Predict the height of Seedling X on Day 5. (1m)
- 
- b) Leonard went for a two-week holiday. He left the two set-ups in his house near a closed glass window. There was no one at home to take care of the seedlings.

Two weeks later, the seedlings died. Why? (1m)

---

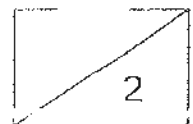

- 33 Table X below provides some information about a group of animals, A, B and C.

Table X

Animal	Has three body parts?	Has gills for breathing?	Reproduces by laying eggs?	Body covered with hair?
A	No	Yes	Yes	No
B	Yes	No	Yes	No
C	No	No	No	Yes

- a) Based on the information given in Table X, write down one characteristic of Animal B. (½ m)

---

- b) From the information given in Table X, choose the correct word and write the answer in the blanks provided. (1½ m)

<del>mammal</del>	<del>bird</del>	<del>fish</del>	<del>insect</del>
-------------------	-----------------	-----------------	-------------------

Animal A : \_\_\_\_\_

Animal B: \_\_\_\_\_

Animal C : \_\_\_\_\_

- c) Give an example of Animal C. (1m)

---

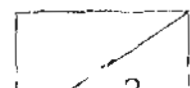

34 Look at the two animals below.



molly



dog

a) What is the similarity between the molly and the dog in their method of reproduction? (1m)

---

b) What is the difference between the molly and the dog in their body covering? (2m)

---

---

35 Study the plant below.



a) Label the parts, P and Q. (1m)

b) What is the function of P? (1m)

---

c) Based on your observation of the diagram above, how does Part Q help Part P? (1m)

---

---

36 Melody set up the following experiment.

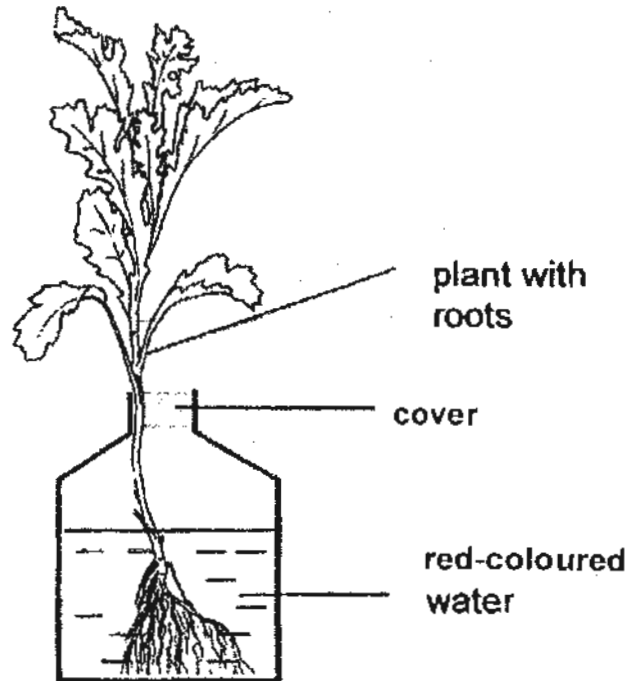

She measured the water level in the container every two days for a week. She found that the water level in the container had dropped.

a) What would Melody observe about the plant after two days? (1m)

---

b) Explain your answer in (a). (1m)

---

c) Melody cut off the roots of the plant and planted it in a pot of soil. She noticed that the plant toppled easily. Why was that so? (1m)

---

37 The diagram below shows a human system.

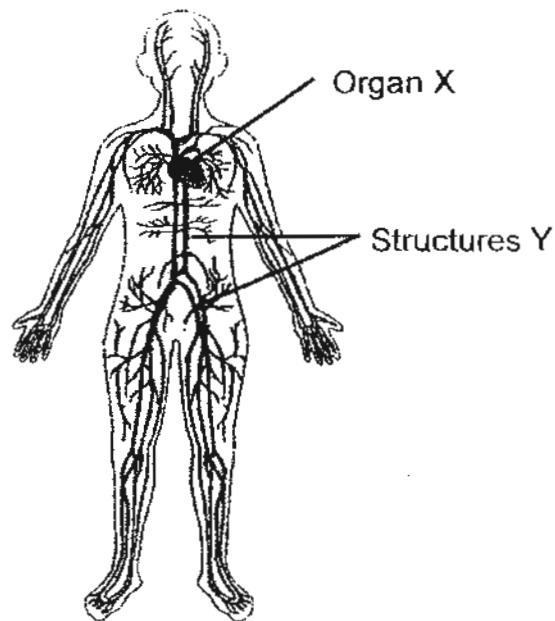

a) Blood is found in the human system above to carry substances around the body. Name two substances that are carried by the blood. (2m)

---

b) Name Organ X. (1m)

---

c) Which part of the skeletal system protects Organ X? (1m)

---

38 George drew the flowchart below to show the flow of food in a human digestive system.

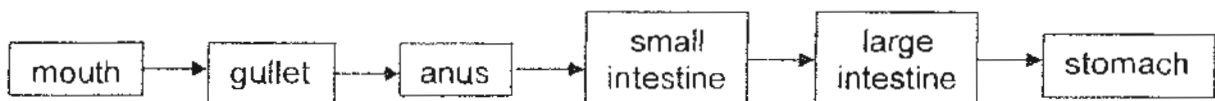

a) George has accidentally placed two organs wrongly. Which are the two organs that he has placed wrongly? (2m)

---

b) What is the function of the large intestine? (1m)

---

- 39 The diagram below shows parts, T, U, V, and W, of the human digestive system.

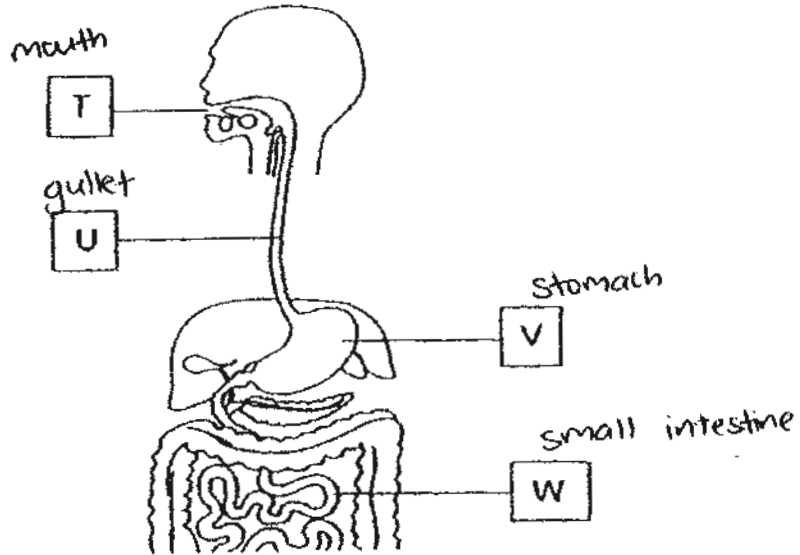

How does the amount of digested food change when it leaves the various parts of the digestive system? Put a tick (✓) in the correct box. (2m)

Part	Amount of Digested Food		
	No Change	Increases	Decreases
T			
U			
V			
W			

- 40 A company, which produces baby products, wanted to test which material, A, B or C, would be the best material to make a baby's feeding bottle (without the cover and the teat). They tested the materials and recorded their findings in the table below.

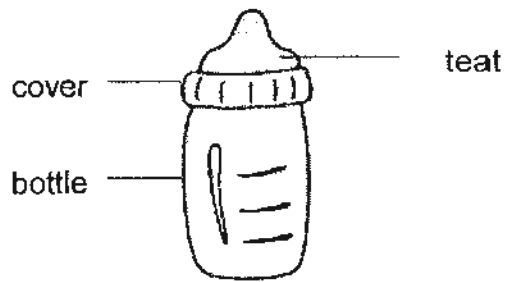

Material	A	B	C
Can it bend?	X	✓	X
Is it waterproof?	✓	✓	✓
Can it be stretched?	X	✓	X
Does it break when dropped?	✓	X	X

- a) Which material, A, B or C, do you think the company will choose to make the baby's feeding bottle? (1m)
- 

- b) Give the most important reason for your answer in Part (a). (1m)
- 

- c) Name one object which can be made of Material B. (1m)
-

- 41 Rayner wrapped three similar objects, P, Q and R, in paper. Then, he held a magnet about two centimetres away from each of them as shown in the diagram below.

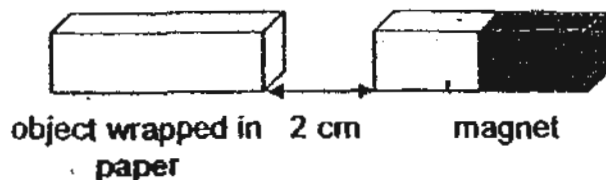

He recorded his observations in the table below.

Object	Observation
P	It remained still.
Q	It moved towards the magnet.
R	It moved away from the magnet.

- a) Which one of the objects (P, Q or R) could be made of aluminium? (1m)

---

- b) Rayner repeated the experiment by turning the magnet around and was able to make Object R move towards it.

Which property about a magnet did he use for Part (b)? (2m)

---

---

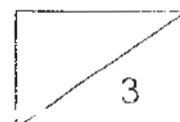

- 42 Elaine bought a pencil case shown below which makes use of two pieces of magnets, A and B, to close itself.

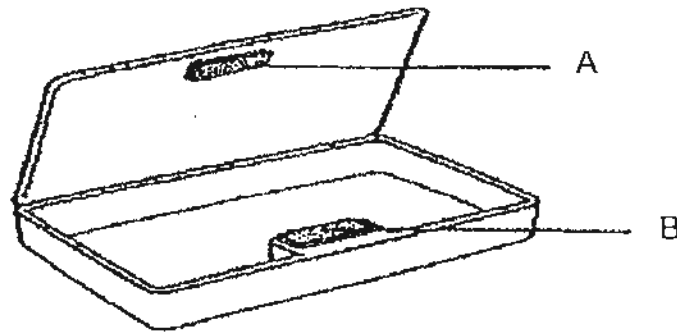

- a) In the space provided, indicate 'N' for the North pole and 'S' for the South pole so that Elaine can close the pencil case tightly. (2m)

Magnet A: \_\_\_\_\_ pole

Magnet B: \_\_\_\_\_ pole

- b) After using the pencil case for a month, Elaine realised that it did not close as tightly as before even when the pencil case was empty.

What could be a possible reason? (1m)

---

---

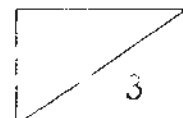

- 43 Evan set up the experiment below using three magnets, X, Y and Z, of similar strength. He held Magnet Z in place using Magnet X as shown.

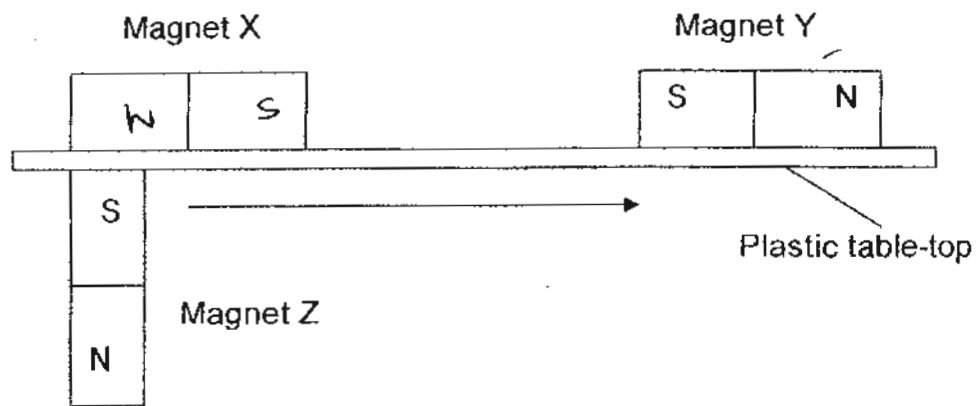

- a) What will happen to Magnet Y if he moves Magnet Z in the direction as indicated by the arrow? (1m)

---

---

- b) If Evan replaces Magnet X with a piece of copper which is similar in size, what will happen to Magnet Z? (1m)

---

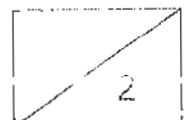

- 44 Derrick wanted to find out how the number of batteries affects the number of paper clips attracted to the electromagnet. He set up the experiment as shown in the diagram below.

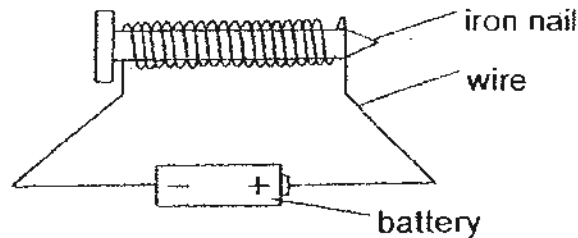

He carried out his experiment using different number of batteries. He drew a graph based on the results of his experiment.

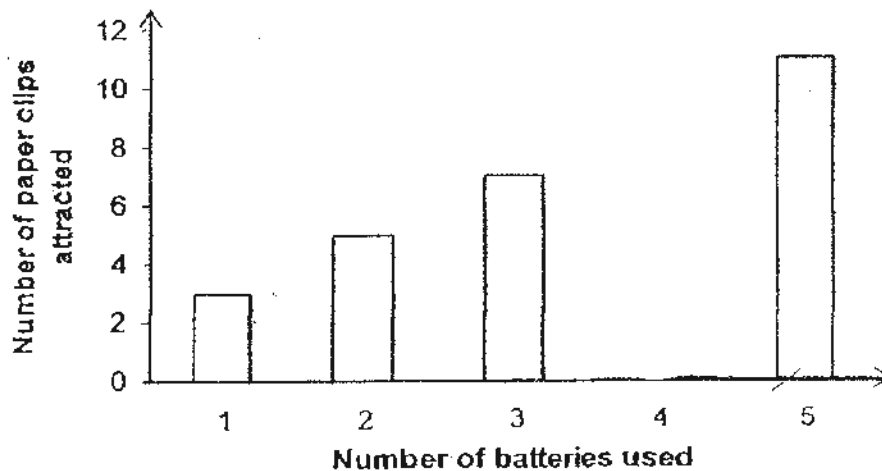

- a) At the end of the experiment, Derrick realised that he made a mistake while recording the data.

Put an 'X' in the bar graph column where he had most likely made the mistake. (1m)

- b) Based on the results shown above, what did Derrick observe when the number of batteries increased from one to three? (1m)

- c) Using the same set-up, predict the number of paper clips that will be attracted if the iron nail is changed to a silver nail. (1m)

**\*\* End of Section B \*\***

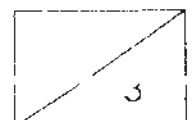

131

# ANSWER SHEET

**EXAM PAPER 2010**

**SCHOOL : RED SWASTIKA PRIMARY**

**SUBJECT : PRIMARY 3 SCIENCE**

**TERM : SA2**

Q1	Q2	Q3	Q4	Q5	Q6	Q7	Q8	Q9	Q10	Q11	Q12	Q13	Q14	Q15	Q16	Q17
1	3	2	2	4	2	2	1	4	4	3	1	3	3	2	2	4

Q18	Q19	Q20	Q21	Q22	Q23	Q24	Q25	Q26	Q27	Q28	Q29	Q30
4	3	3	1	3	4	2	2	4	1	2	3	4

- 31a) A: Flowering  
B: Non-flowering
- 31b) Bittergourd. It is an edible plant.
- 32a) 8cm
- 32b) There was no water.
- 33a) Animal B has three body parts /reproduces by laying eggs.
- 33b) Animal A: fish  
Animal B: insect  
Animal C: mammal
- 33c) It is an elephant.
- 34a) They both give birth to young.
- 34b) The molly has scales while the dog has hair.
- 35a) P: leaf  
Q: stem
- 35b) It is to help make food for the plant.
- 35c) Part Q twirls around the stick for support in order to let part P reach for sunlight.
- 36a) The leaves turned red.
- 36b) The roots of the plant absorb the red-coloured water.
- 36c) Without the roots, the plant could not hold itself firmly to the soil.
- 37a) It is to carry waste food materials and oxygen.
- 37b) Heart
- 37c) Rib cage
- 38a) Anus and stomach
- 38b) The large intestine absorbs water from undigested food.
- 39) T: increases  
U: no change  
V: increase  
W: increases

40a) C

40b) It will not break when dropped.

40c) Rubber band

41a) P

41b) Unlike poles of magnets attract each other,

42a) Magnet A: N pole

Magnet B: S pole

42b) The magnet had lost its magnetism.

43a) Magnet Y will be repelled by magnet X.

43b) Magnet Z will not be held in place by the copper and will drop.

44a)

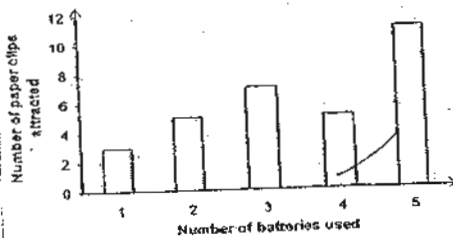

44b) As the number of batteries increased, the number of paper clips attracted to the electromagnet also increase.

44c) 0