

CHIJ ST NICHOLAS GIRLS' SCHOOL

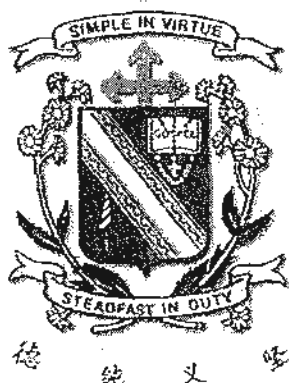

Second Semestral Assessment

2010

Primary 3 SCIENCE

(BOOKLET A)

2 November 2010

Total Time for Booklets A and B: 1 hour 45 minutes

30 questions

60 marks

INSTRUCTIONS TO CANDIDATES

- Do not open this booklet until you are told to do so.
- Follow all instructions carefully.
- Answer all questions.

This paper consists of 14 printed pages.

Section A : (30 x 2 MARKS)

For each question from 1 to 30, 4 options are given. One of them is the correct answer. Make your choice (1, 2, 3 or 4). Shade the correct answer (1, 2, 3 or 4) in the Optical Answer Sheet (OAS) provided.

1. The things below are classified according to their ability to move on their own.

Group X	Group Y
Elephant Aeroplane Staghorn fern	Balloon Scissors Stopwatch

Which one of the following is placed in the **wrong** group?

- (1) Balloon
 - (2) Aeroplane
 - (3) Stopwatch
 - (4) Staghorn fern
2. The picture below shows a Mimosa plant.



Which of the following statements are characteristics of the Mimosa plant?

- A It cannot move.
 - B It responds to touch.
 - C It reproduces by seeds.
 - D It grows towards sunlight.
- (1) A and D only
 - (2) B and C only
 - (3) B, C and D only
 - (4) A, B, C and D only

3. Which of the following statements demonstrate characteristics of living things?

- A The flower bud becomes bigger after two weeks.
- B Teresa drank a glass of water when she was thirsty.
- C The leaves of a balsam plant move as the wind blows.
- D Tom's shirt gets wet after he accidentally spills some milk on it

- (1) A and B only
- (2) C and D only
- (3) A, B and D only
- (4) A, B, C and D only

4. The picture below shows a battery operated potted plant. It can play a song and its flower and leaves will move when light shines on it.



Why is the potted plant not a living thing?

- (1) It does not grow taller.
- (2) It needs food to move.
- (3) It moves when there is light.
- (4) It can make its own food using its leaves.

5. Which of the following animals can be placed in the same group according to the way they reproduce?

- A Moth
- B Guppy
- C Platypus
- D Grasshopper

- (1) A and D only
- (2) B and C only
- (3) A, B and D only
- (4) A, C and D only

6. The table below shows the characteristics displayed by four organisms, W, X, Y and Z.

Organisms	Need to look for food	Can move from place to place	Reproduce from seeds
W	Yes	Yes	No
X	No	No	No
Y	No	No	No
Z	No	No	Yes

Which of the following pairs of organisms represent an animal and a flowering plant?

	Animal	Flowering plant
(1)	W	Z
(2)	W	Y
(3)	X	Z
(4)	X	Y

7. Jackie did a study on two animals, X and Y. He placed a tick (✓) in the checklist below when he made the observation. The completed checklist is as follows:

Observation	Animal X	Animal Y
It gives birth to young alive.	✓	
It lives on land.		✓
It has six legs.		✓

Which of the following animals **cannot** be Animal X or Y?

- A Rabbit
- B Dolphin
- C Penguin
- D Crocodile

- (1) A and D only
- (2) B and C only
- (3) A, C and D only
- (4) A, B, C and D

8. The pictures below show two organisms, X and Y.

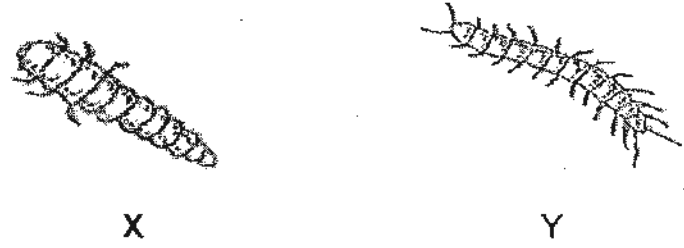

Based on what you can see, which one of the following statements describes organisms, X and Y, correctly?

- (1) They are insects.
- (2) They have segmented body.
- (3) They respond to light and touch.
- (4) They move slowly from place to place.

9. Study the classification chart below.

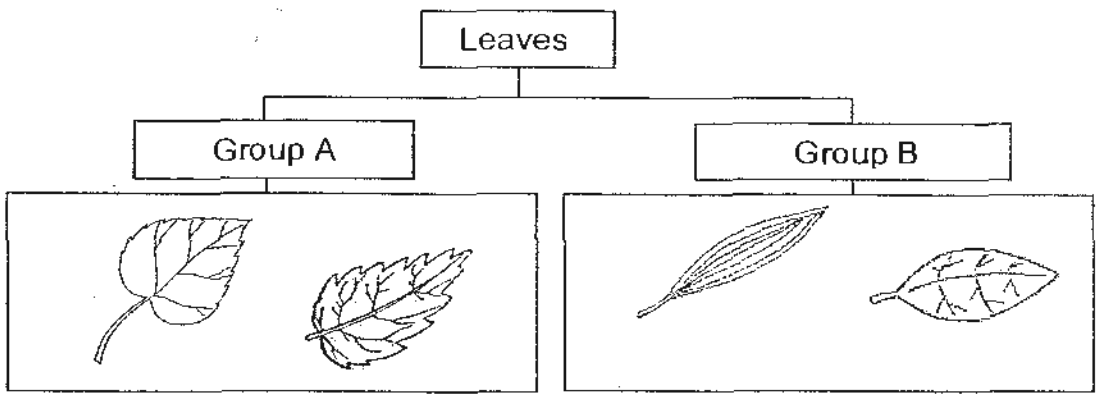

The leaves are being classified according to their _____.

- (1) edge
- (2) shape
- (3) texture
- (4) vein pattern

10. The pictures below show some toadstools and some moulds on a piece of bread.

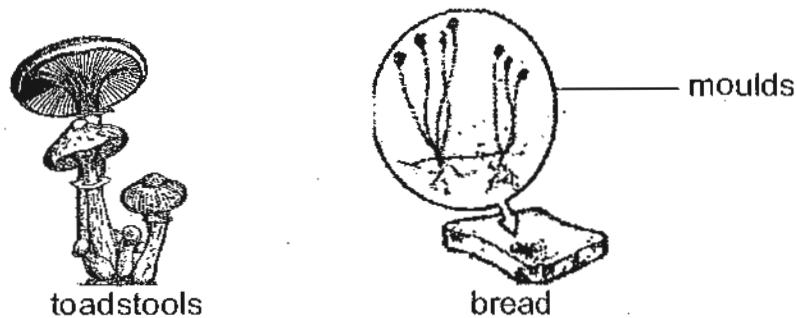

Which one of the following statements about the toadstools and the moulds on the bread is false?

- (1) Both grow from spores.
- (2) Both feed on decaying matter.
- (3) Both need air, food and water.
- (4) Both need sunlight to make food.

11. Which of the following statements about all bacteria are true?

- A They produce their own food.
- B They are harmful to the human body.
- C They cannot be seen with naked eyes.
- D They come in various shapes and sizes.

- (1) A and B only
- (2) C and D only
- (3) B, C and D only
- (4) A, B, C and D

12. Study the picture of the balloon shown below.

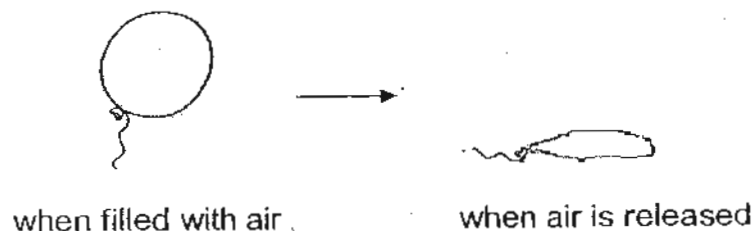

Which one of the following properties allows the balloon to be filled with air?

- (1) It is hard.
- (2) It is colourless.
- (3) It is waterproof.
- (4) It is stretchable.

13. The diagram below shows a bottle in a tub of water.

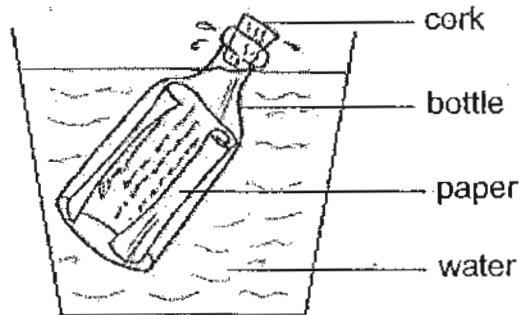

Four children gave different explanations when asked why the paper inside the bottle will not get wet. Who is correct?

- Abigail : The bottle is waterproof.
Belinda : The bottle is transparent.
Claudia : The cork will not get wet.
Desiree : The cork is hard and strong.

- (1) Abigail
(2) Belinda
(3) Claudia
(4) Desiree

14. The picture below shows a chair.

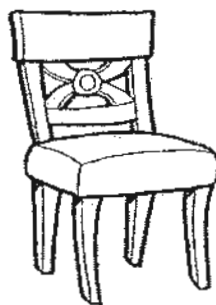

Which one of the following properties is most important when choosing a suitable material to make the chair?

- (1) It is hard.
(2) It is strong.
(3) It is very comfortable.
(4) It can withstand high temperature.

15. Which of the following objects is/are made from natural materials?

- A Silk scarf
- B Cotton blouse
- C Woollen jumper
- D Polyester swimming cap

- (1) B only
- (2) A and C only
- (3) B and D only
- (4) A, B and C only

16. Derek set up an experiment to test the strength of 3 strips made of different materials but of the same shape and sizes by adding 10-gram weights, one at a time on the metal clip, until the strip broke.

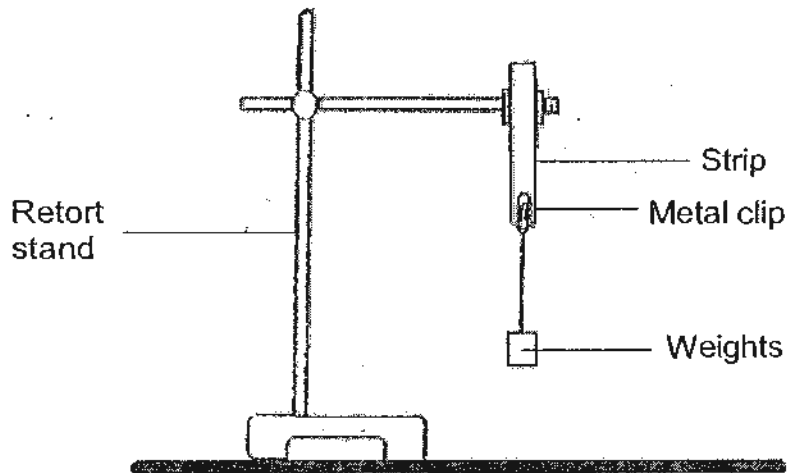

The table below shows the number of weights each material, X, Y and Z, can take before it breaks.

Materials	Number of weights it can take
X	20
Y	14
Z	8

Which of the following materials are best represented by X, Y and Z respectively?

	Paper	Metal	Plastic
(1)	X	Y	Z
(2)	Z	Y	X
(3)	Y	X	Z
(4)	Z	X	Y

17. Diagrams X and Y show the movement of materials in the tiny tubes in the stem of a plant.

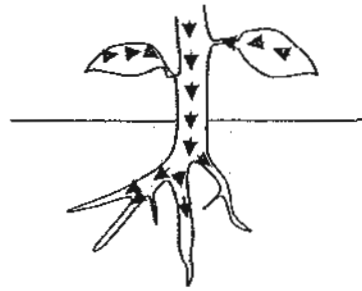

Diagram X

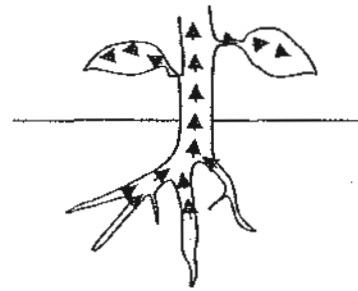
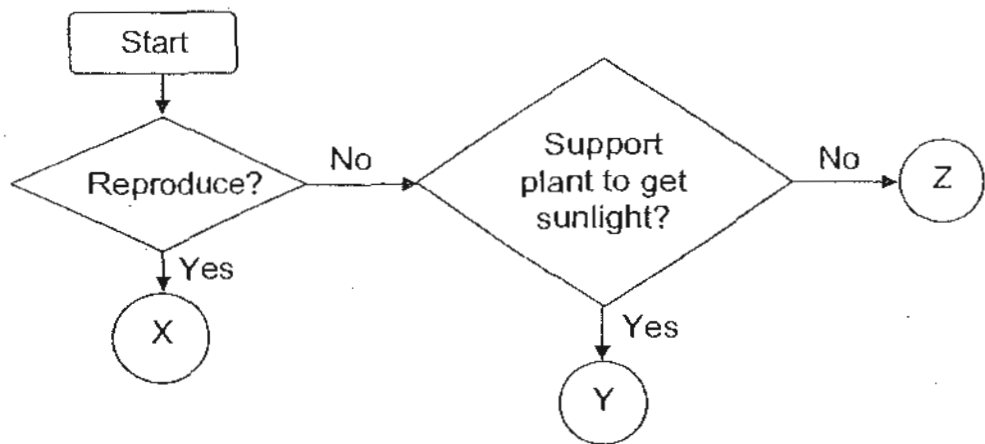

Diagram Y

Which one of the following shows the correct materials being transported?

	Food	Water	Mineral salts
(1)	X	Y	X
(2)	Y	X	X
(3)	X	Y	Y
(4)	X	X	Y

18. The flow chart below describes the functions of some parts of a plant.



Based on the flow chart, which of the following represent X, Y and Z respectively?

	X	Y	Z
(1)	Seeds	Leaves	Roots
(2)	Flowers	Roots	Leaves
(3)	Leaves	Flowers	Stem
(4)	Seeds	Stem	Roots

19. Study the classification chart below.

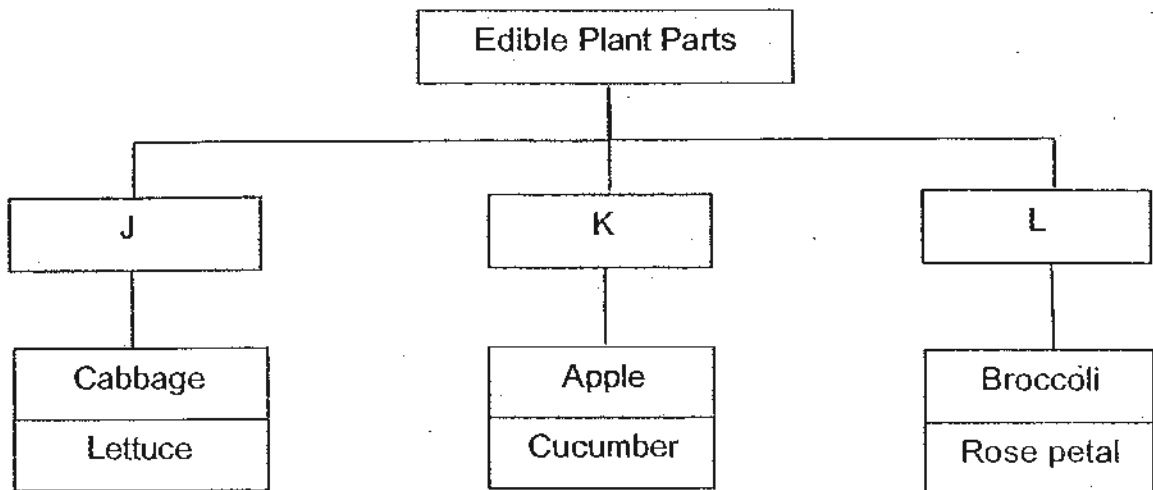

Which of the following represent J, K and L respectively in the chart above?

	J	K	L
(1)	Roots	Seeds	Flowers
(2)	Stem	Fruits	Leaves
(3)	Leaves	Flowers	Fruits
(4)	Leaves	Fruits	Flowers

20. Study the flow chart shown below.

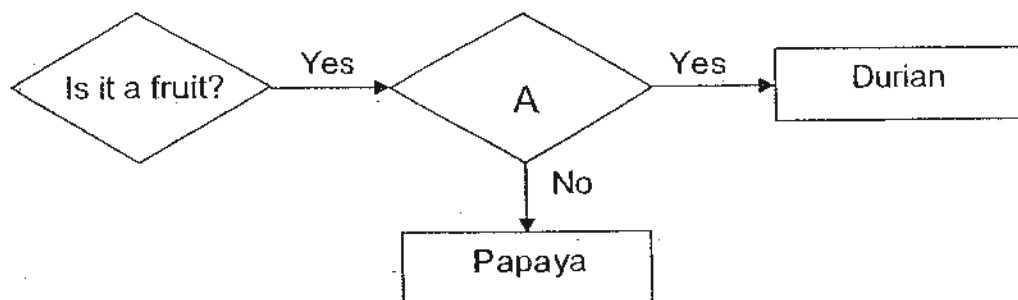

Which one of the following questions should be placed in A?

- (1) Is it big?
- (2) Is it edible?
- (3) Does it have rough skin?
- (4) Does it have small seeds?

21. Derek sorted some fruits according to the number of seeds in the classification chart shown below.

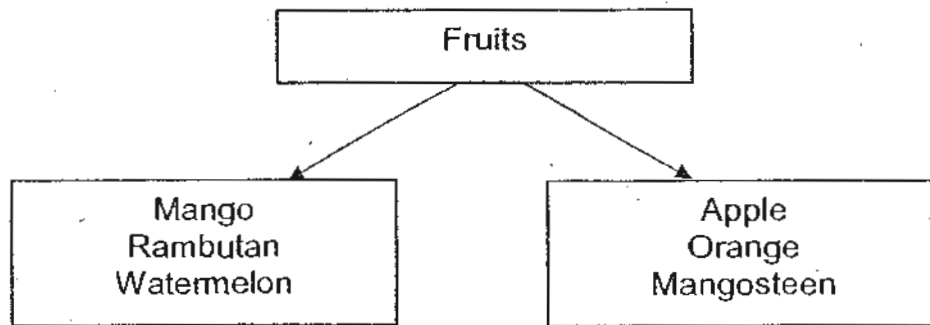

Which one of the following fruits is placed in the **wrong** group?

- (1) Mango
 - (2) Rambutan
 - (3) Watermelon
 - (4) Mangosteen
22. Which one of the following pairs of organs are parts of the human circulatory system?
- (1) heart and lungs
 - (2) lungs and windpipe
 - (3) heart and blood vessels
 - (4) lungs and blood vessels
23. Study the diagram of a human system shown below.

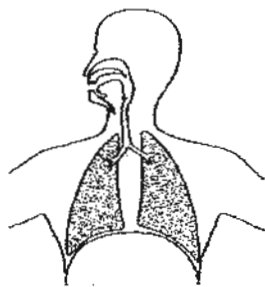

Which one of the following describes the function performed by the system?

- (1) It protects important organs.
- (2) It carries digested food around the body.
- (3) It supports and enables body movement.
- (4) It exchanges gases with the surroundings.

24. Which one of the following materials is being absorbed in the large intestine?

- (1) Food
- (2) Water
- (3) Undigested food
- (4) Unwanted gases

25. Study the picture shown below.

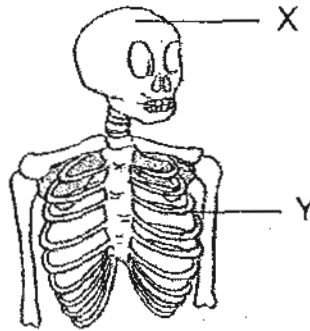

Which one of the following statements about X and Y is correct?

- (1) X and Y provide the body with muscles.
- (2) X and Y protects vital organs to ensure survival.
- (3) X is a more important organ than Y in the human body.
- (4) X and Y have to work together to enable the body to move.

26. Which of the following describe the food when it moves into the gullet?

- A It is smaller and softer.
- B It has changed its colour.
- C It has been partially digested.
- D It can be absorbed into the bloodstream.

- (1) A and C only
- (2) B and D only
- (3) B and C only
- (4) A and D only

27. Study the classification chart below.

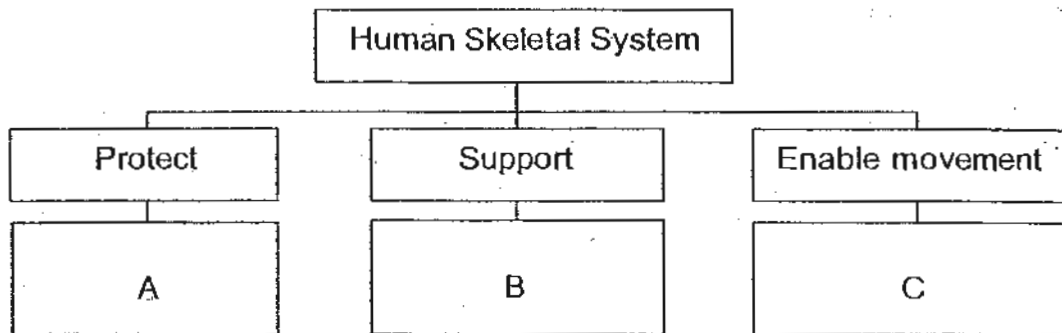

Which of the following human organs are represented by A, B and C respectively?

	A	B	C
(1)	Hand bone	Hip bone	Backbone
(2)	Backbone	Skull	Hip bone
(3)	Hand bone	Backbone	Skull
(4)	Ribcage	Backbone	Hand bone

28. The diagrams below show the different stages in the life cycle of a bean plant.

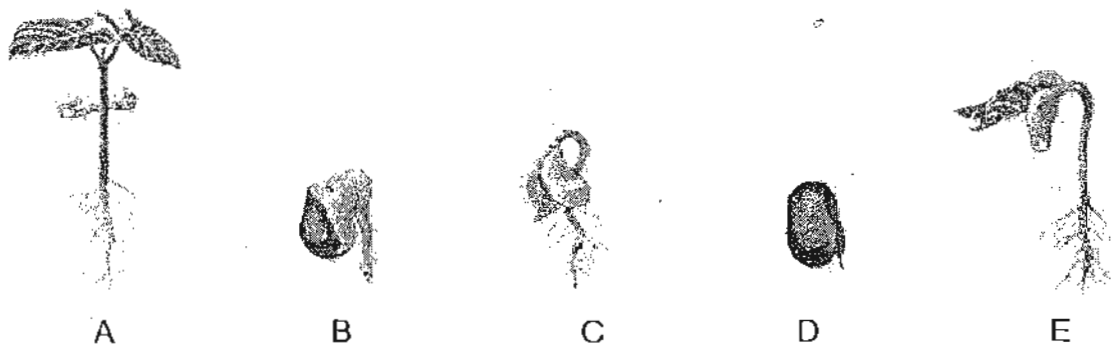

Which one of the following shows the correct order of growth of the bean plant?

- (1) B → C → E → A → D
- (2) C → A → B → D → E
- (3) D → B → C → E → A
- (4) A → D → B → E → C

29. Which one of the following is not a cycle?

- (1) Four seasons
- (2) Day and night
- (3) Baking of a cake
- (4) Reproduction of animals

30. Which one of the following shows the life cycle of a flowering plant?

(1)

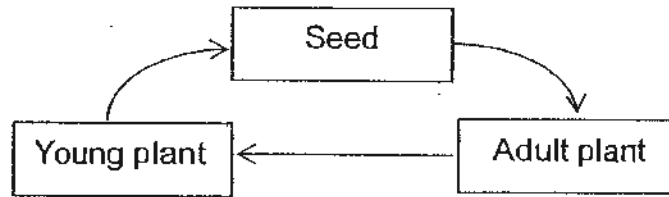

(2)

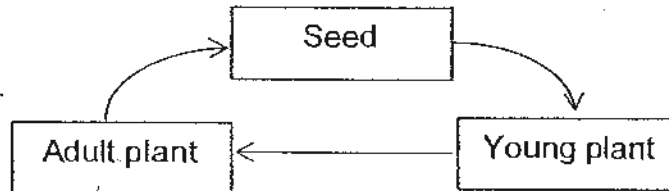

(3)

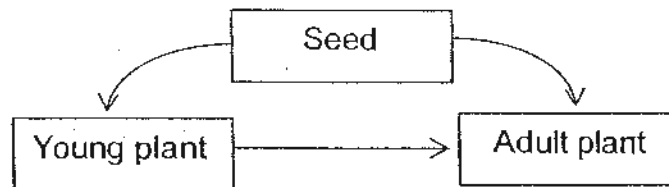

(4)

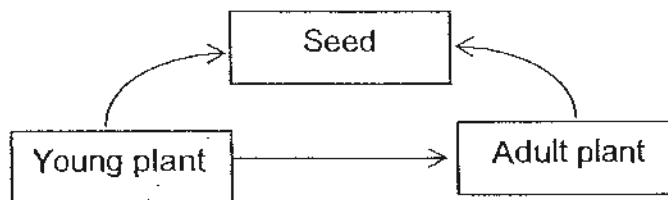

----- End of Section A -----

NAME : _____)

CLASS: PRIMARY 3 _____

CHIJ ST NICHOLAS GIRLS' SCHOOL



Second Semestral Assessment

2010

Primary 3 SCIENCE

(BOOKLET B)

2 November 2010

Total Time for Booklets A and B: 1 hour 45 minutes

14 questions

40 marks

INSTRUCTIONS TO CANDIDATES

- Do not open this booklet until you are told to do so.
- Follow all instructions carefully.
- Answer all questions.

Booklet A	60
Booklet B	40
Total	100

Parent's Signature/Date

This paper consists of 11 printed pages.

Section B : (40 marks)

For questions 31 to 44, write your answers in this booklet.

The number of marks available is shown in brackets [] at the end of each question or part question.

31. The picture below shows a pigeon on the ground. Mark caught sight of it and walked gently towards it.



- (a) What would happen to the pigeon when Mark walked nearer to it? [1m]

- (b) What characteristic of living things is shown above? [1m]

32. The picture below shows a diver swimming underwater.

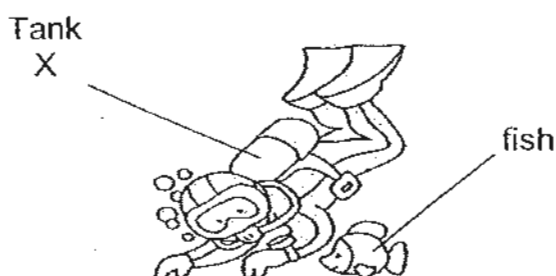

- (a) What does tank X contain? [1m]

- (b) Can the fish live underwater without tank X? Explain your answer. [1m]



33. The pictures below show two animals, a cat and a grasshopper.

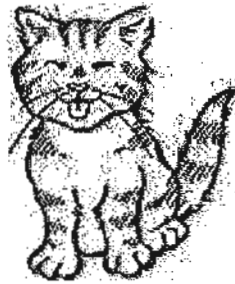

Cat



Grasshopper

(a) How are the cat and the grasshopper alike? [1m]

(i) _____

(ii) _____

(b) Write down two differences in the following characteristics between the cat and the grasshopper. (Do not compare shape, size and colour.) [2m]

(i) Difference in reproduction :

(ii) Difference in body covering :



34. The picture below shows a bird.

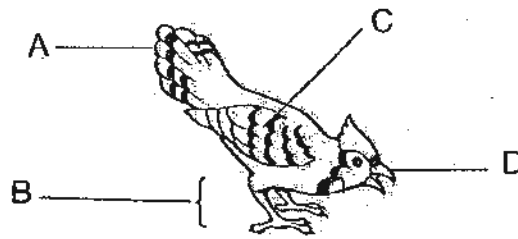

(a) Name the body parts of the bird.

[2m]

A : _____

B : _____

C : _____

D : _____

(b) (i) Which two body parts, A, B, C or D, help the bird to move?

[1m]

(ii) How do the body parts you have stated in b(i) enable the bird to move?

[1m]



35. Study the flow chart shown.

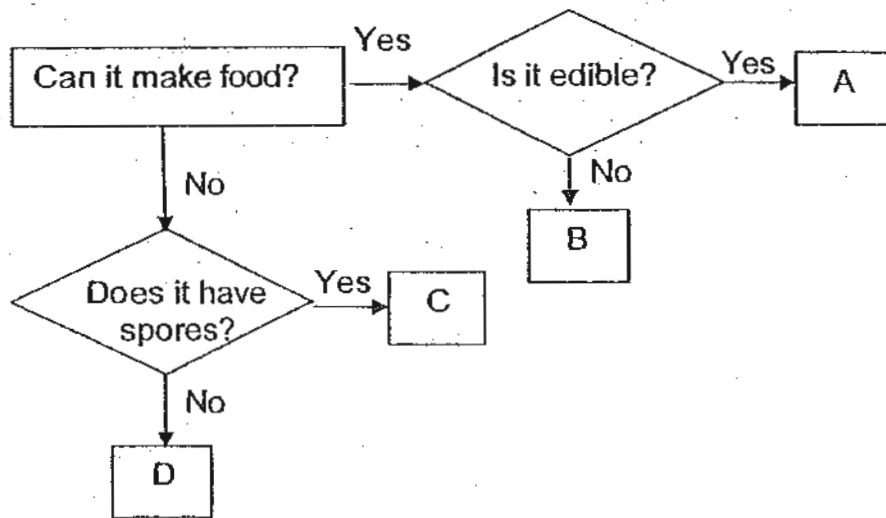

(a) Write down the letters (A, B, C or D) correctly in the boxes provided. [2m]

Living things	Letter
Toadstool	
Ginger plant	
Hippopotamus	
Bird's Nest Fern	

(b) State the difference between A and C. [1m]

36. Study the flow chart shown below.

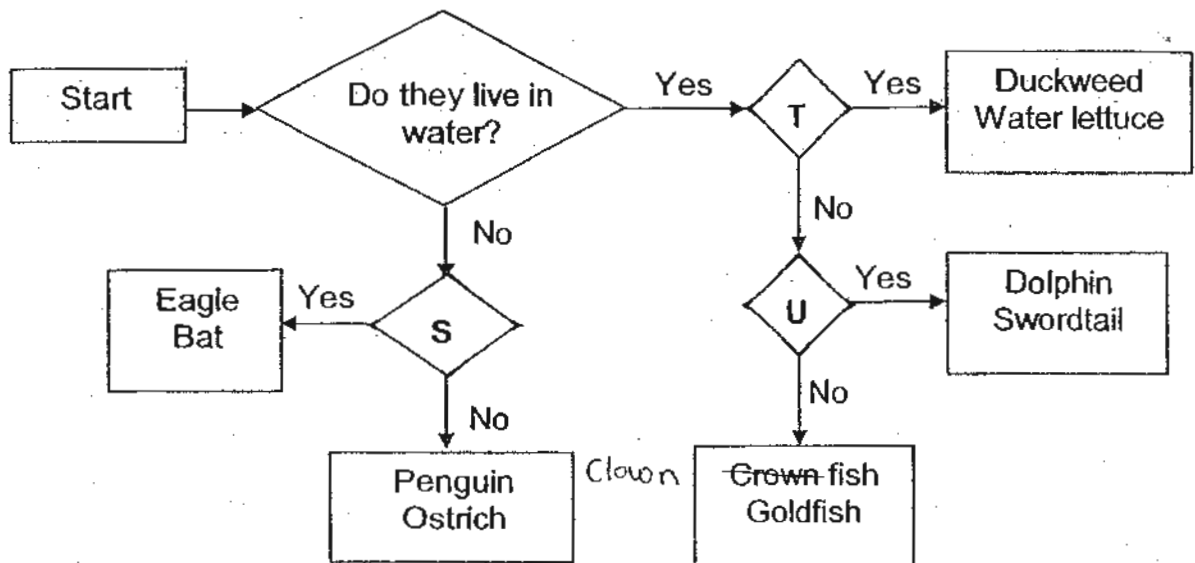

The letters, S, T and U, each represents a question in the flow chart. Write the letter (S, T or U) in the correct boxes to complete the flow chart. Each letter can only be used once.

[3m]

Questions	Letter
Can they fly?	
Can they make food?	
Do they have four legs?	
Do they have hair?	
Do they lay eggs?	
Do they give birth to young alive?	



37. The picture below shows a flag on a flagpole.

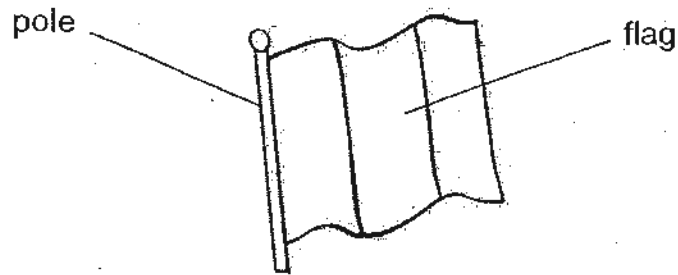

(a) Write down a suitable material for the following parts seen above. [1m]

Pole : _____

Flag : _____

(b) State their difference in flexibility between the pole and the flag. [1m]

38. Classify the following objects according to their ability to sink or float in water. [3m]

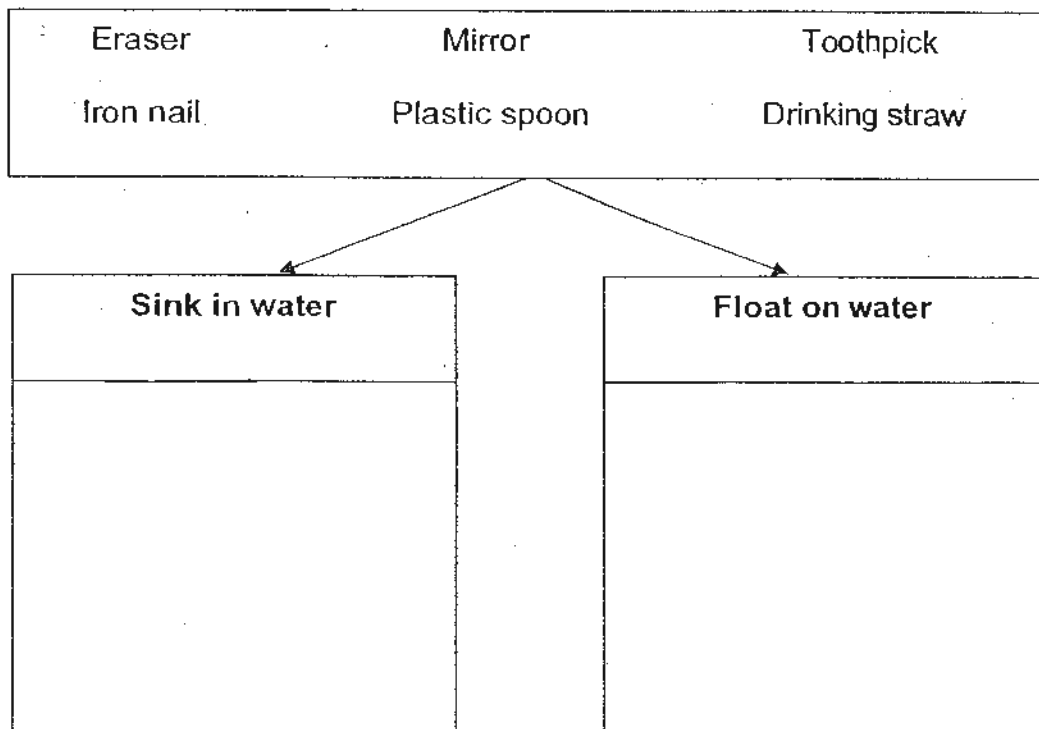

39. Ryan pushed 4 solid balls, P, Q, R and S, of similar shape and size, one at a time into the bottom of a basin of water. The diagram below shows what he observed after he released the balls in the water.

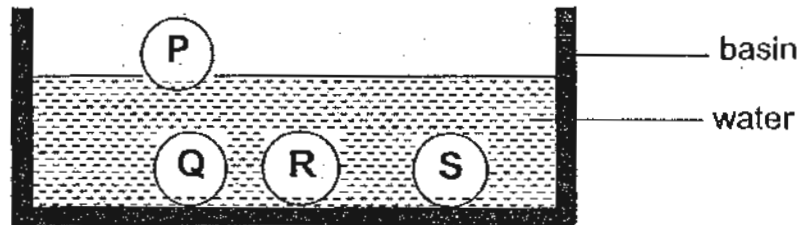

Balls	Does it break when dropped?	Can it be scratched easily?
P	No	Yes
Q	Yes	No
R	No	Yes
S	No	No

- (a) Based on the description of each ball given above, write down the letter, P, Q, R or S, into the correct boxes below. Each letter can be used only once. [2m]

Material	Letter
Metal	
Ceramic	
Wood	
Rubber	

- (b) Which is harder, metal or rubber? Explain your answer. [1m]



40. The diagrams below show two plants, A and B, which have been uprooted from the garden soil.

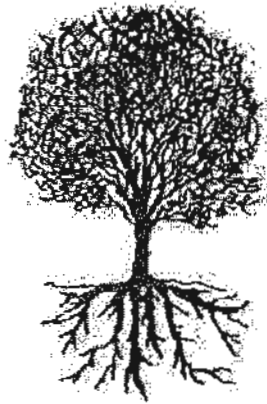

Plant A



Plant B

- (a) Based on what you can see, write down the differences between the stems and the roots of Plant A and Plant B. (Do not compare shape and colour.)

[2m]

- (i) Difference in stems :

- (ii) Difference in roots :

- (b) Will the uprooted plants be able to survive? Explain your answer.

[1m]



41. The diagram below shows the view of a plant when you look at it from the top.

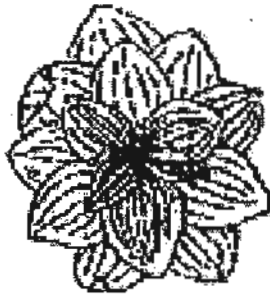

(a) Observe the leaves arrangement in the above diagram. Explain how such an arrangement helps the plant in its growth. [1m]

(b) Study the diagrams shown below.

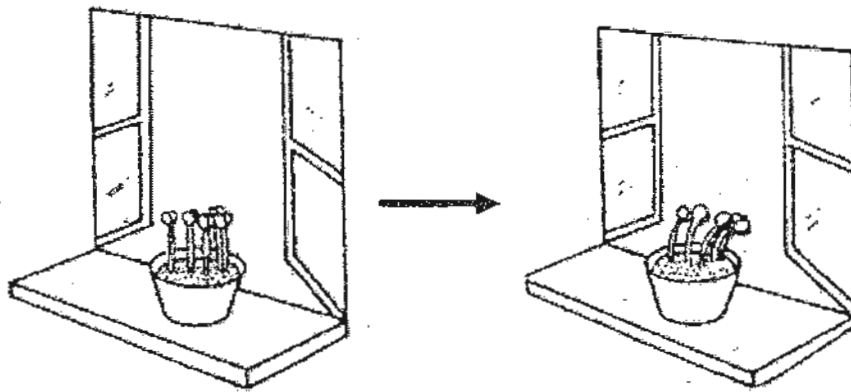

Diagram 1

Diagram 2

Give a reason why the plant in diagram 1 grows in the way as shown in diagram 2 after one week. [1m]



42. The diagram below shows the human digestive system.

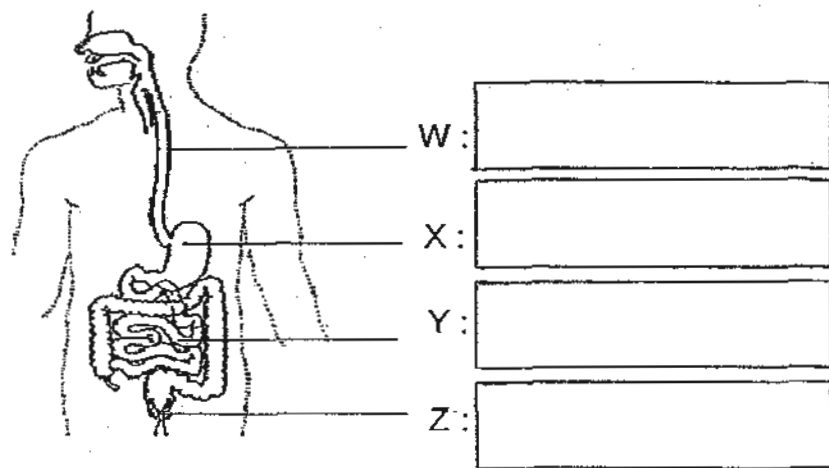

(a) Identify the parts, W, X, Y and Z, in the boxes shown above. [2m]

(b) State the functions of parts, W and Y. [2m]

W : _____

Y : _____

43. Describe the function of the following parts of the mouth.

(a) Teeth [1m]

(b) Tongue [1m]

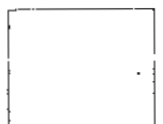

44. Fiona placed a seed on some wet cotton in a plastic bag. She kept the cotton wet and recorded her observations over two weeks in the table shown below.

Day Number	Length of shoot (mm)	Length of root (mm)
1	0	0
2	0	1
4	0	4
6	4	7
8	12	11
10	21	15
12	32	20
14	41	24

Based on the table shown above, answer the following questions.

- (a) State all the conditions that were present for the seed to grow. [1m]

- (b) Predict the length of the shoot and the root on the 7th day. [1m]

Shoot : _____ Root : _____

- (c) Which part of the seedling grew first? Explain your answer. [1m]

- (d) What can you conclude about the growth of the shoot and the root? [1m]

----- End of Paper -----



ANSWER SHEET

EXAM PAPER 2010

SCHOOL : CHIJ ST NICHOLAS GIRLS' PRIMARY

SUBJECT : PRIMARY 3 SCIENCE

TERM : SA2

Q1	Q2	Q3	Q4	Q5	Q6	Q7	Q8	Q9	Q10	Q11	Q12	Q13	Q14	Q15	Q16	Q17
2	3	1	1	4	1	3	2	1	4	2	4	1	2	4	4	3

Q18	Q19	Q20	Q21	Q22	Q23	Q24	Q25	Q26	Q27	Q28	Q29	Q30
4	4	3	3	3	4	2	2	1	4	3	3	2

31a) The pigeon will fly away.

31b) Living things respond to changes.

32a) Tank X contains oxygen.

32b) Yes. The fish has gills to breathe underwater.

33ai) Both the cat and the grasshopper can reproduce.

33aii) Both the cat and the grasshopper can grow.

33bi) The cat gives birth to young alive while the grasshopper gives birth by laying eggs.

33bii) The cat is covered by fur while the grasshopper is covered by an exo-skeleton.

34a) A: tail
B: legs
C: wing
D: beak

34bi) Part B and C.

34bii) Part B helps the bird to hop while part C helps the bird to fly.

35a) Toadstool: C
Ginger plant: A
Hippopotamus: D
Bird's Nest Fern B

35b) A can make food while C cannot.

36) Can they fly? S

Can they make food? T

Do they give birth to young alive? U

37a) Pole: Metal

Flag: Fabric

37b) The pole is inflexible while the flag is flexible.

38)

Sink in water	Float on water
Eraser Iron nail Mirror	Plastic spoon Drinking straw Toothpick

39a) Metal: S

Ceramic: Q

Wood: P

Rubber: R

39b) Metal. Metal is harder than rubber because it cannot be scratched easily.

40ai) Plant A has a thick stem while plant B has a thin stem.

40aii) Plant A has long roots while plant B has short roots.

40b) No. The roots cannot absorb water and mineral salts from the ground.

41a) The leaves will get as much sunlight as possible to make food and the stem will transport it to other parts of the plant.

41b) The plant is growing towards the sunlight.

42a) W: gullet

X: stomach

Y: small intestine

Z: anus

42b) W: The gullet pushes the partially digested food down to the stomach.

Y: The completely digested food is absorbed into the bloodstream.

43a) The teeth grind the food into smaller pieces.

43b) The tongue rolls food into small balls to make it easier for swallowing and also tasting the food.

44a) Air, water and warmth.

44b) Shoot: 8
Root: 9

44c) The root. It absorbs water and mineral salts from the ground soil.

44d) The root grows before the shoot does, but as days passed, the length of the shoot is even longer than the length of the root.