



**CATHOLIC HIGH SCHOOL
PRIMARY 4
SEMESTRAL ASSESSMENT 1, 2010**

SCIENCE

Name: _____ ()

Class : Primary 4 _____

Date : 25 May 2010

BOOKLET A

30 Questions
60 Marks

Total Time for Booklets A & B : 1 hour 30 minutes

Instructions to Candidates

Do not open this booklet until you are told to do so.
Follow all instructions carefully.
Answer all questions.

Section A: Multiple Choice Questions (60 marks)

For each question from 1 to 30, four options are given. One of them is the correct answer. Make your choice (1, 2, 3 or 4) on the Optical Answer Sheet.

1. Junbiao has some plants in his garden. What is the reason for Junbiao to know that they are non-flowering plants?
- (1) They have big leaves.
 - (2) They have weak stems.
 - (3) Fruits can be found on the plants.
 - (4) Spores can be found on the underside of the leaves.

2. The characteristics of ~~four~~ ^{three} organisms are given in the table below. A tick (✓) means that the organism has that particular characteristic.

Characteristics	P	Q	R
It reproduces by spores and cannot make its own food.	✓		
It has 3 body parts, a pair of feelers and can fly.		✓	
It has a pair of wings and a body covered with feathers.			✓

Identify the set of organisms that represent P, Q and R.

	P	Q	R
(1)	Seagull	Dragonfly	Bee
(2)	Dragonfly	Housefly	Seagull
(3)	Toadstool	Bee	Seagull
(4)	Bird's nest fern	Dragonfly	Sparrow

3. Study the flow chart below carefully.

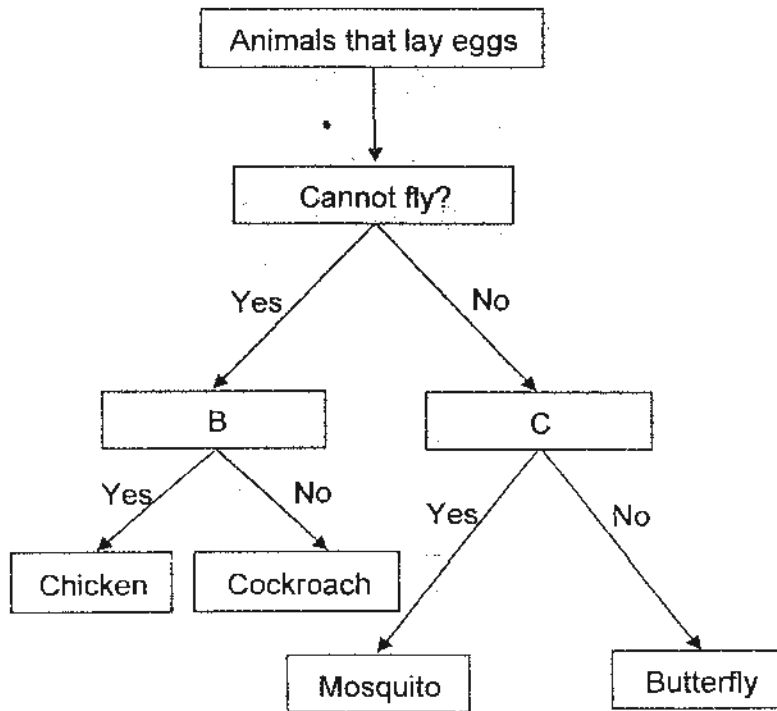

What are the suitable headings for B and C?

	B	C
(1)	Can swim?	Can crawl?
(2)	Has a beak?	Harmful to humans?
(3)	Has pupae stage?	Undergoes moulting?
(4)	Young looks like adult	Young does not look like adult

4. What are the common characteristics of ferns and fungi?

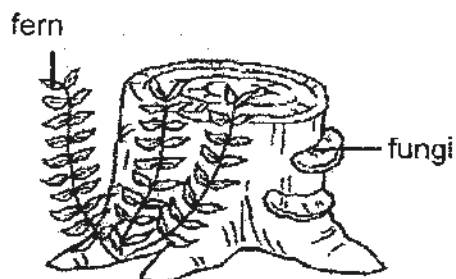

- A They do not bear flowers.
- B They make their own food.
- C They obtain food from the surroundings.
- D They respond slowly to changes around them.

- (1) A and B only
- (2) A, C and D only
- (3) B, C and D only
- (4) A, B, C and D only

5. Clara did an experiment to track the path of food in her digestive system. The diagram below shows where the food was found at different times of that day.

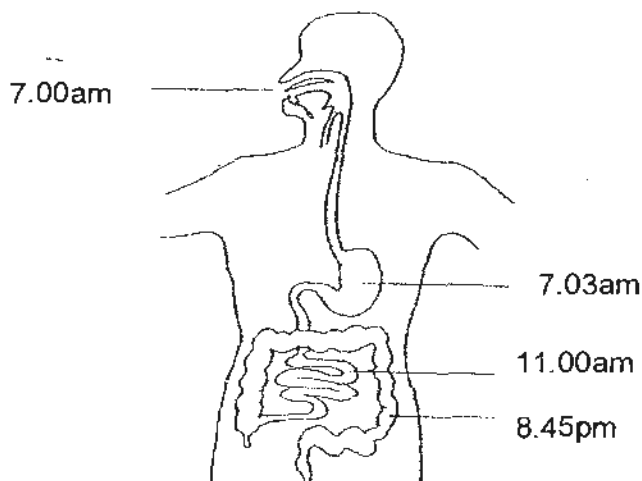

At about what time was Clara's digested food absorbed into the blood stream?

- (1) 7.00 am
- (2) 7.03 am
- (3) 11.00 am
- (4) 8.45 pm

6. Which of the following statements are true about the human digestive system?

- A There is no digestive juice in the mouth.
- B Food is digested completely in the stomach.
- C The large intestine is shorter than the small intestine.
- D Inside the large intestine, most of the water from the undigested food is absorbed by the body

- (1) A and B only
- (2) C and D only
- (3) A and D only
- (4) B, C and D only

7. Jennifer puts some banana into her mouth. She tries to hold her tongue to the base of her mouth and then bites and chews the banana without moving her tongue. What will happen next?

- (1) Saliva will not be secreted.
- (2) The food will not be broken down.
- (3) The food will pass through the gullet easily.
- (4) The food will not be able to mix well into a ball.

8. A baby picked up some food from the floor and swallowed it. Soon after, she began vomiting. Which part of the digestive system below did the vomit come from?

- (1) mouth
- (2) stomach
- (3) small intestine
- (4) large intestine

9. Anselm tried very hard to pull out the plants from his garden, but he could not. What can you tell about the roots of the plants that Anselm was trying to pull out from his garden?

- (1) The plants have short roots.
- (2) The roots of the plants store food for the plants.
- (3) The roots of the plants take in water for the plants.
- (4) The roots of the plants have grown deep into the ground.

10. Study the flow chart below carefully.

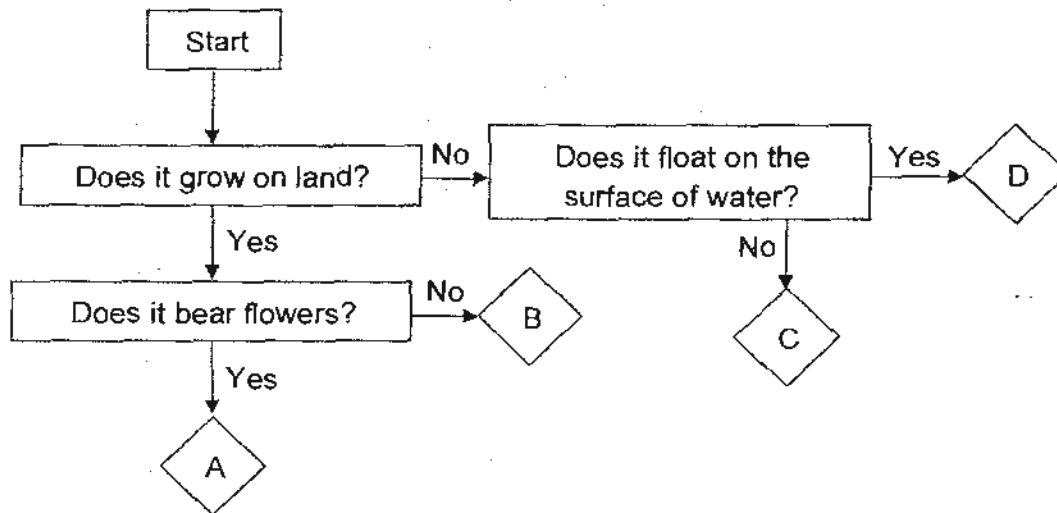

Which of the following sets represents A, B, C and D correctly?

	A	B	C	D
(1)	Rose	Hydrilla	Tree Fern	Duckweed
(2)	Rose	Tree Fern	Duckweed	Hydrilla
(3)	Hibiscus	Mushroom	Hydrilla	Duckweed
(4)	Hibiscus	Hydrilla	Mushroom	Duckweed

11. Aslinda set up the following experiment. She poured 400 ml of water into two identical containers, A and B. Then she poured a layer of oil on the surface of water in both containers. She placed one plant into Container A. Both containers were left near an open window for 4 days. She recorded the amount of water in each container daily and showed the results in a bar graph.

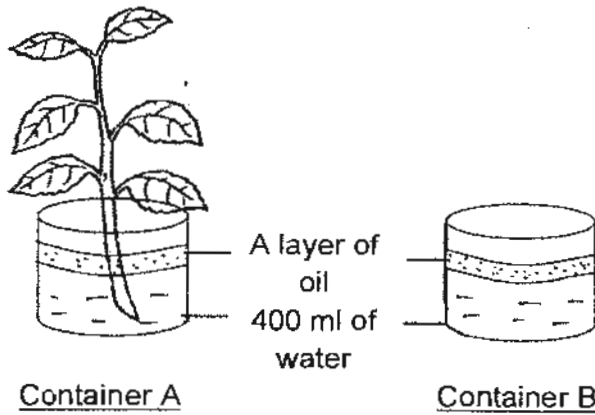

Based on the above experiment, which one of the following bar graphs shows the correct amount of water in each container?

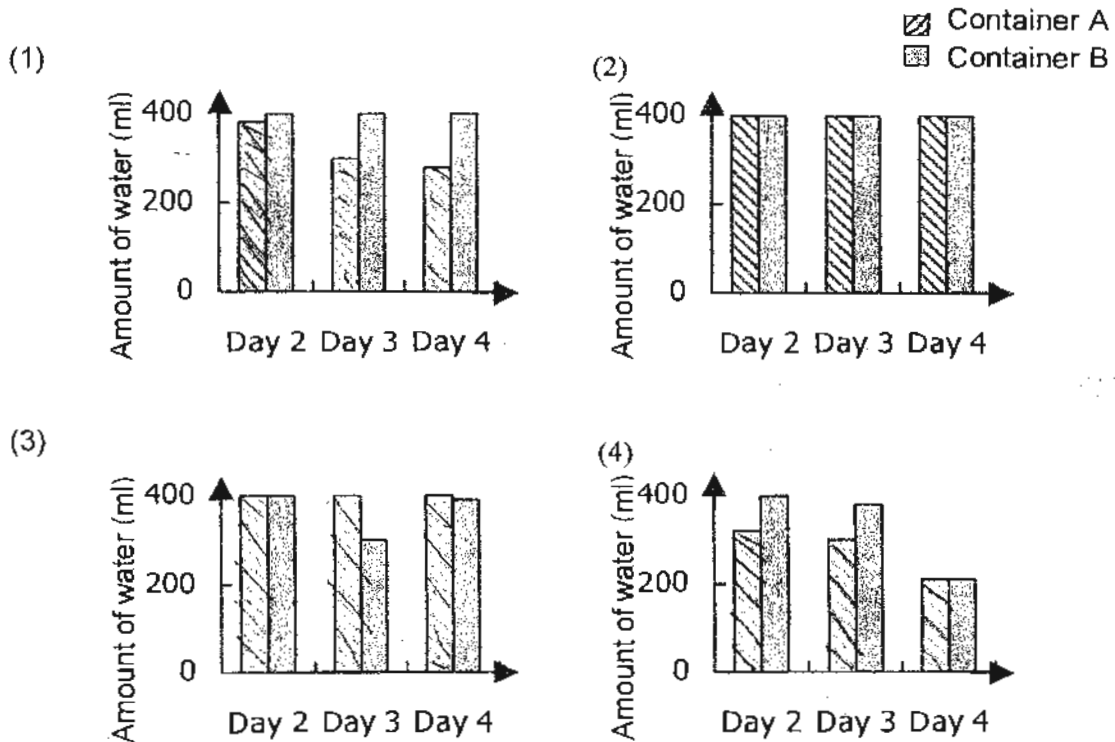

12. Siti was describing a certain animal, X, to John.

Siti Its young does not look like the adult. It has three stages in its life cycle. The adult lives on both land and water.

Based on Siti's observation, which animal can X be?

- (1) frog
- (2) duck
- (3) turtle
- (4) crocodile

13. The graph below shows the temperature of a particular place from January to December.

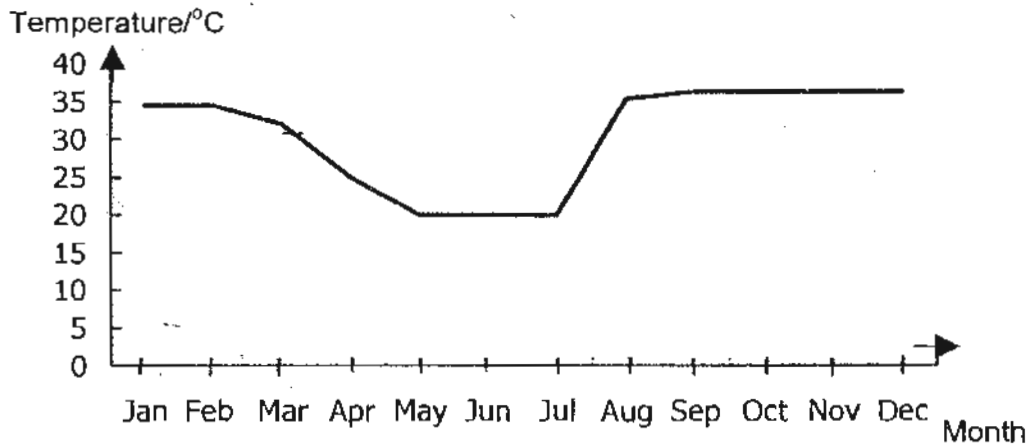

Insect Z lives in this place. It requires a temperature of between 30°C and 35°C for at least one month to develop from an egg to an adult.

Which of the following months are suitable for Insect Z to breed?

- (1) January to March
- (2) April to July
- (3) August to September
- (4) May to December

14. Which one of these statements about plants is false?

- (1) Roots help take in water and mineral salts from the soil.
- (2) Each seed has seed leaves that provide food for the seed.
- (3) The shoot appears before the root during germination of a seed.
- (4) Each new plant goes through the same life cycle as the parent plant.

15. David kept two containers of seeds in the kitchen. The diagram below shows what he placed in the containers A and B at the beginning.

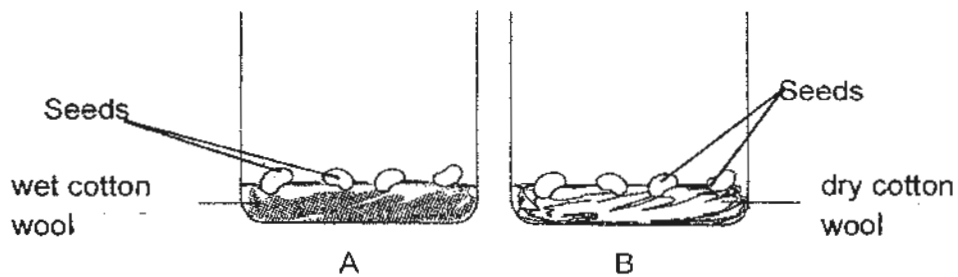

After 5 days, only the seeds in container A grew into small plants. The seeds in container B did not grow because they did not get any _____.

- (1) light
- (2) water
- (3) food
- (4) warmth

16. Study the flow chart below.

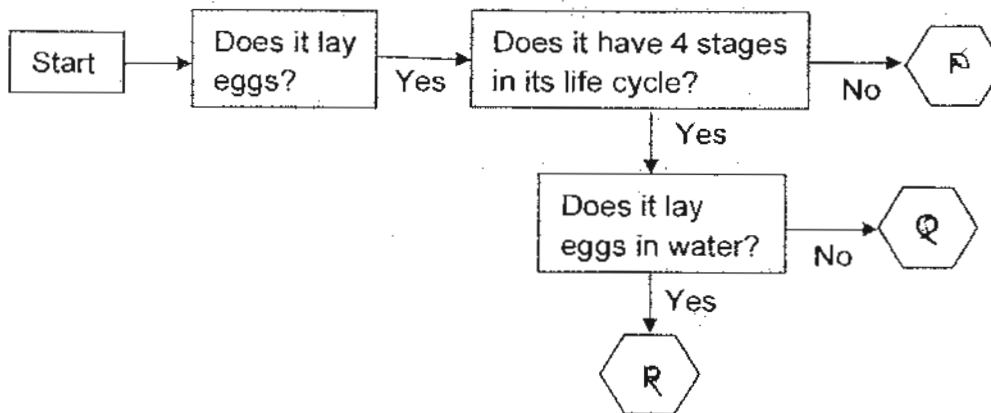

Based on the flow chart above, what could Animal P, Q and R be?

	P	Q	R
(1)	Chicken	Butterfly	Mosquito
(2)	Chicken	Mosquito	Moth
(3)	Dragonfly	Butterfly	Chicken
(4)	Dragonfly	Moth	Chicken

17. The graph below shows the number of days in each stage of the life cycle of an insect which lives in the water.

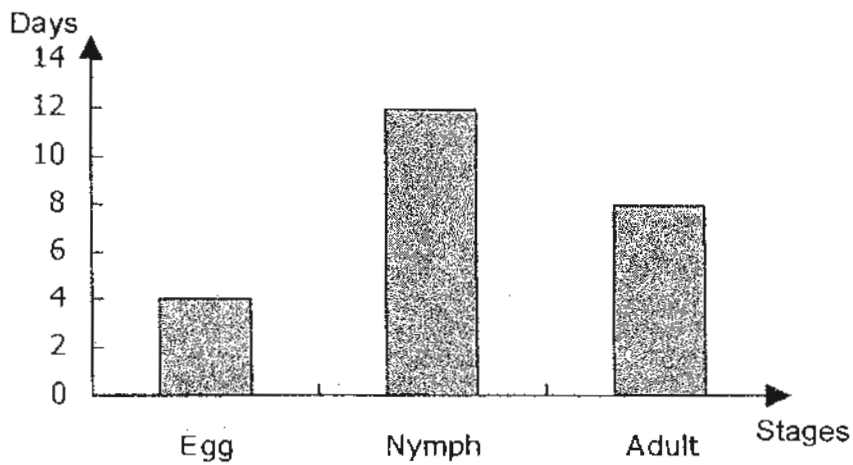

Which of the following information obtained from the graph is correct?

- (1) The insect's lifespan is less than 3 weeks.
- (2) The insect takes 8 days to become a nymph.
- (3) The insect lives in the water for 12 days as a nymph.
- (4) It takes 24 days to become an adult after the egg is hatched.

18. Four thin pieces of materials W, X, Y and Z of the same size, were weighed individually before they were put into the beakers of water show below.

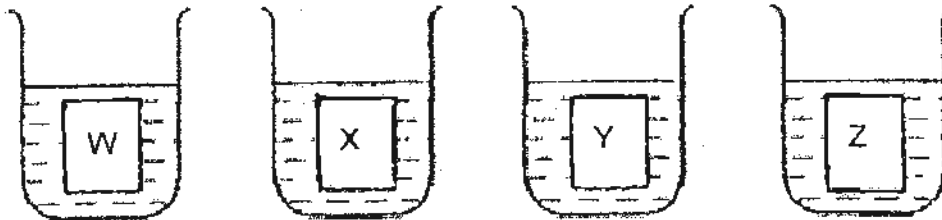

After 15 minutes, each piece was weighed again. Their masses were recorded in the table below.

Material	Mass at the beginning/g	Mass after 15 minutes/g
W	8	10
X	10	20
Y	12	12
Z	13	11

Which material is the most suitable for making a disposable cup?

- (1) W
- (2) X
- (3) Y
- (4) Z

19. Study the two groups of objects below.

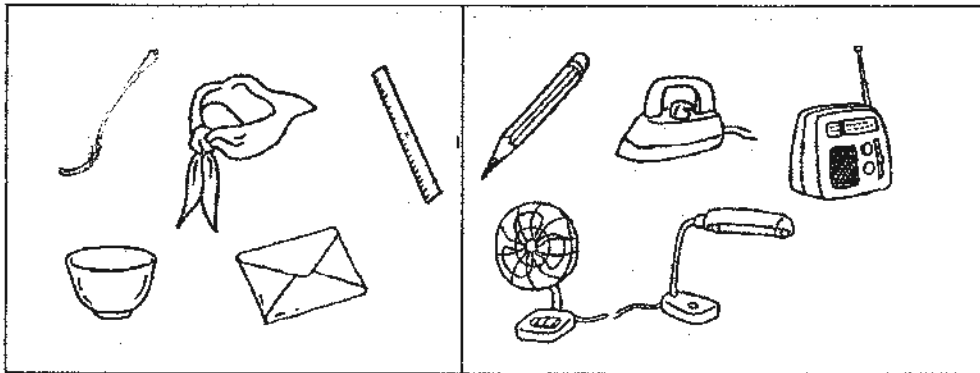

Group A

Group B

What will be the suitable headings for Group A and Group B?

	Group A	Group B
(1)	float on water	sink in water
(2)	flexible	not flexible
(3)	water-absorbent	waterproof
(4)	made of only 1 material	made of different materials

20. Four types of material A, B, C and D, are made into threads and tied to heavy objects. When the heavy objects are lifted by the threads, threads A and C snap as shown below.

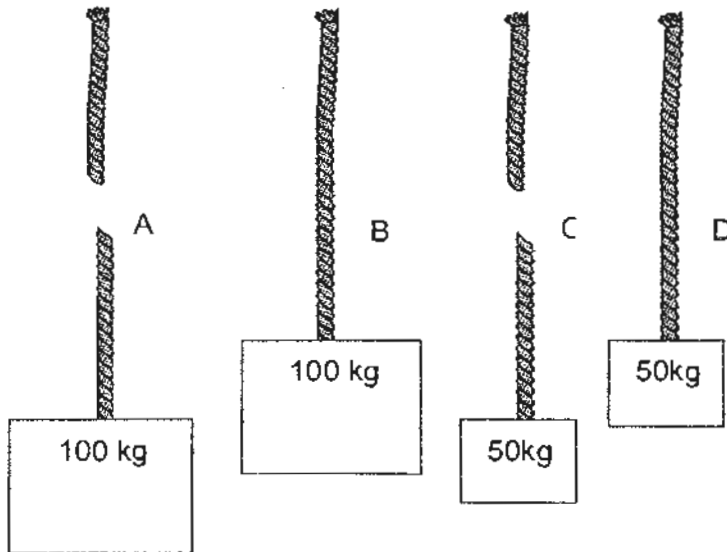

Which one of the following statements is correct about the material that were used to lift the objects?

- (1) Material A is stronger than material B.
- (2) Material B is stronger than material C.
- (3) Material C is stronger than material D.
- (4) Material C is stronger than material B.

21. Mindy has 3 rods labelled A, B and C.

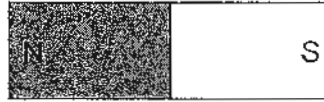
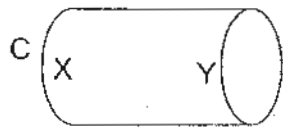
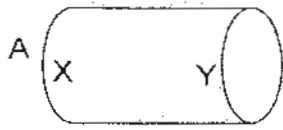

She carried out a simple test by bringing a bar magnet near each of the 3 rods. She then recorded her results in the table below.

Rod	Test results
A	X was attracted to the north pole of the magnet. Y repelled from the north pole of the magnet.
B	X was attracted to the north pole of the magnet. Y was also attracted to both poles of the magnet.
C	Both X and Y were not attracted to the two poles of the magnet.

Which of the following statements about rod A, B and C is most likely to be correct?

- (1) Rod A and B are magnets.
- (2) Rod B is a temporary magnet.
- (3) Rod C is made of a magnetic material.
- (4) Rod A and B are made of magnetic materials.

22. Benson placed objects D, E, F, G and H through a pole and the diagram below shows his observation.

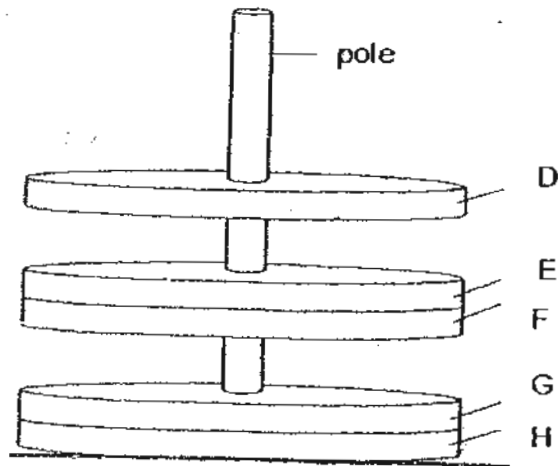

	Conclusion	True	False	Not possible to tell
A	Object D is a magnet	√		
B	All 5 objects are magnets	√		
C	Object H is made from a magnetic material		√	
D	The like poles of objects D and F are facing each other			√

Which one of the following are correctly matched according to Benson's observation?

- (1) A only
- (2) A and B only
- (3) B and C only
- (4) A, C and D only

23. Alan conducted an experiment using 2 similar magnets as shown below.

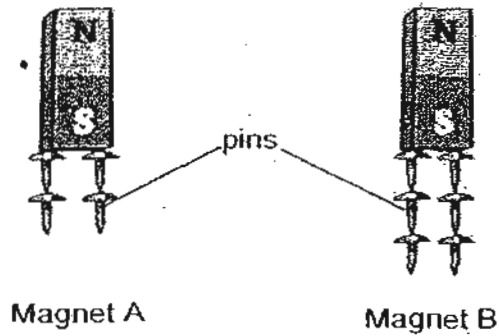

His experiment showed that _____

- (1) the pins are made of steel.
- (2) Magnet B is an electromagnet.
- (3) a Magnet is strongest at its poles.
- (4) magnet B is stronger than magnet A.

24. Study the classification table below.

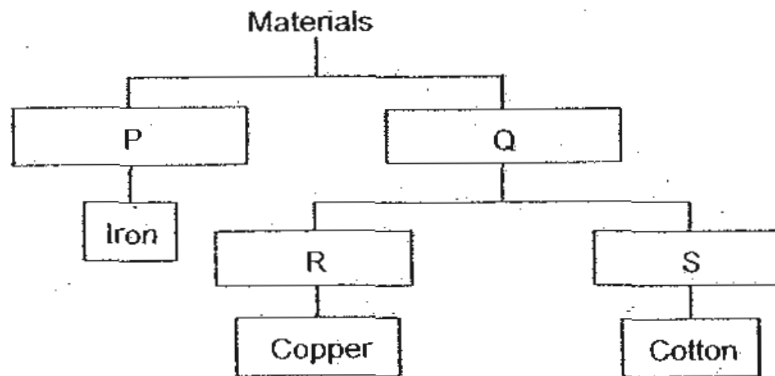

What can the subheadings P, Q, R and S be?

	P	Q	R	S
(1)	Hard	Soft	Metal	Non-metal
(2)	Magnetic	Non-magnetic	Metal	Non-metal
(3)	Rigid	Flexible	Magnetic	Non-magnetic
(4)	Metal	Non-metal	Waterproof	Not waterproof

25. The diagram below shows a container with a capacity of 500 cm^3 .

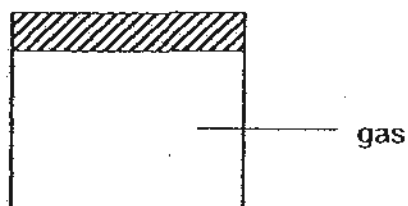

Which of the following statements are true?

- A There is 500 cm^3 of gas in the container.
- B The gas takes up the shape of the container.
- C No more gas can be pumped into the container.
- D The mass of the gas is the mass of the container.

- (1) A and B only
- (2) B and D only
- (3) A, B and D only
- (4) A, B, C and D only

26. Below is a diagram of three identical syringes are filled with different substances and the nozzle of each syringe is covered with a finger.

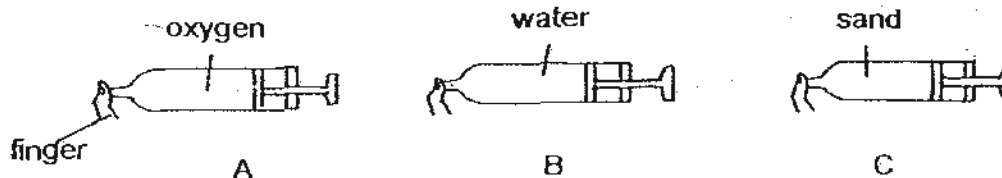

The plunger(s) of syringe(s) _____ will move when pushed.

- (1) A only
- (2) A and B only
- (3) B and C only
- (4) A, B and C only

27. Study the diagrams below carefully.

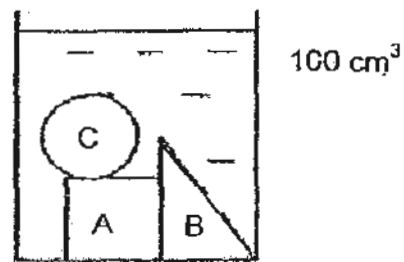
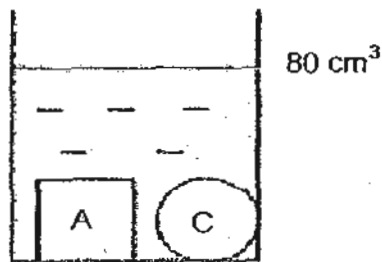
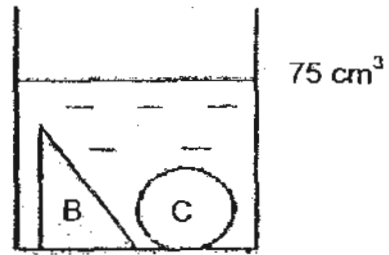
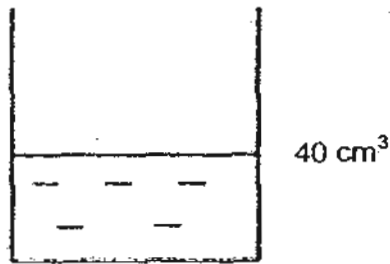

Based on the above diagrams, which of the following statement(s)¹ is/are correct?

- A The volume of object B is 20 cm^3 .
- B The volume of object C is 15 cm^3 .
- C The volume of objects A and B is 15 cm^3 .
- D The volume of objects A, B and C is 100 cm^3 .

- (1) D only
- (2) A and B only
- (3) A and D only
- (4) B and C only

28. X, Y and Z describes the 3 states of matter.

- X Definite volume and definite shape
- Y Definite volume and no definite shape
- Z No definite volume and no definite shape

The changes in the state of water are shown below.

Water → Steam → Water → Ice

Use X, Y and Z to represent the above changes.

- (1) X → Y → X → Z
- (2) X → Z → Y → X
- (3) Y → X → Z → Y
- (4) Y → Z → Y → X

29. Mariam filled a 300ml beaker with 100ml of water. She then attached a 100ml syringe full of air to the beaker as shown in the diagram below.

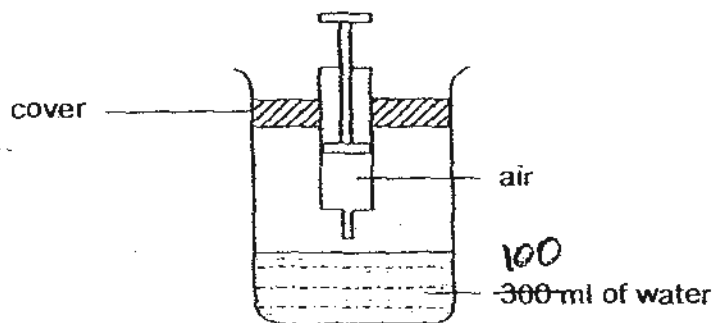

Mariam pushed the plunger of the syringe such that all the air in the syringe was pumped into the beaker. Then she removed the syringe. What would be the final volume of air in the beaker?

- (1) 100ml
- (2) 200ml
- (3) 300ml
- (4) 500ml

30. Study the diagram below. An experiment is carried out using a ruler, strings, and 2 balloons filled with air.

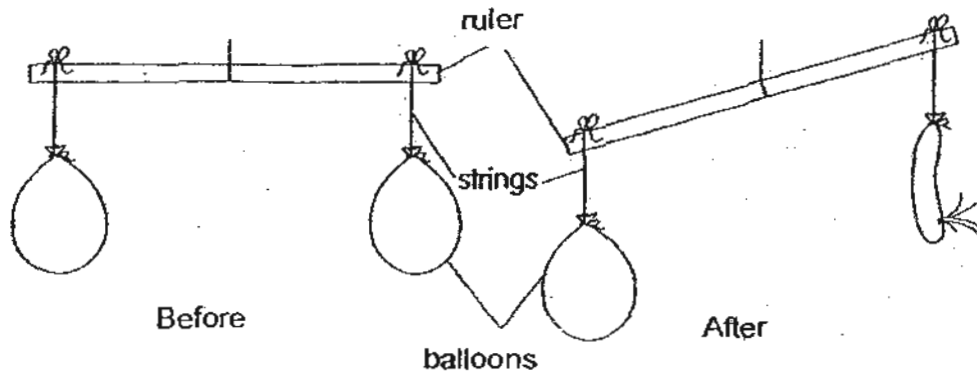

It is to show that _____

- (1) air has mass.
- (2) air occupies space.
- (3) balloons have mass.
- (4) the ruler can be balanced by balloons.

— End of section A —



**CATHOLIC HIGH SCHOOL
PRIMARY 4
SEMESTRAL ASSESSMENT 1, 2010**

SCIENCE

Name: _____ (

Class : Primary 4 _____

Date : 25 May 2010

BOOKLET B

16 Questions
40 Marks

Total Time for Booklets A & B: 1 hour 30 minutes

Instructions to Candidates

Follow all instructions carefully.
Answer all questions.

Parent's Signature: _____

Date: _____

Score	
Section A	60
Section B	40
Total	100

Section B: Open-Ended Questions (40 marks)

Read the following questions carefully and write your answers in the space provided.

The maximum mark that can be awarded is shown at the end of each question or part-question.

31. John claims that both a whale and a shark are fish.

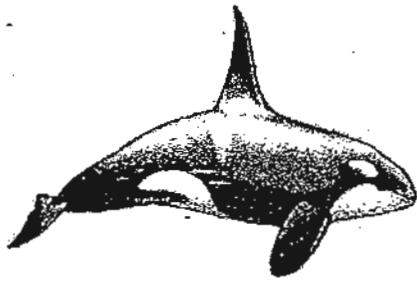

Whale

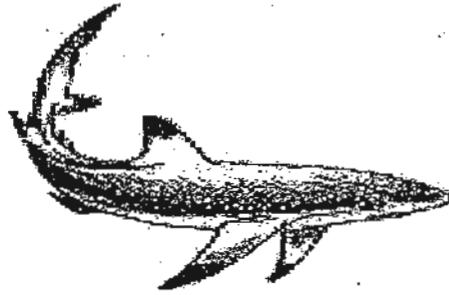

Shark

(a) Is John correct? Write down 2 reasons to explain your answer. [2]

(b) Why do most fish lay a lot of eggs at one time? [1]

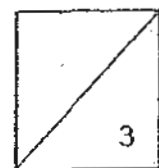

32. Doris conducted an experiment to show the movement of digested food in one part of the digestive system. The diagram below shows her set up.

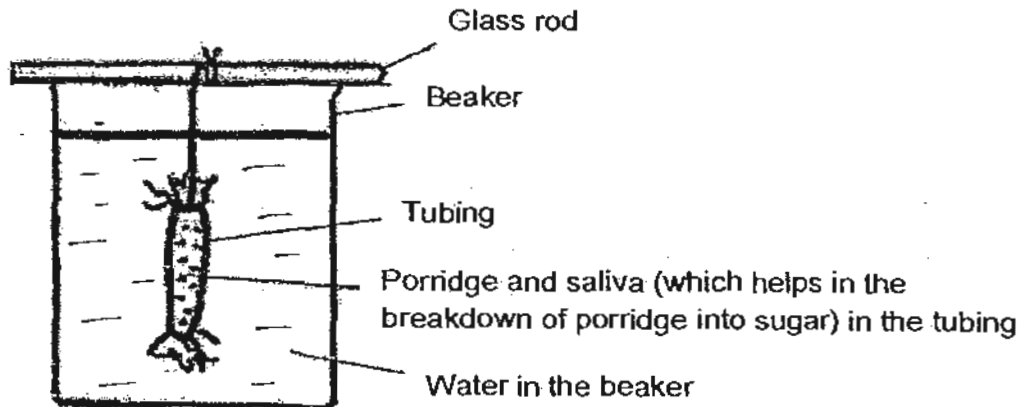

At the beginning of the experiment, she tested the water in the beaker and the solution in the tubing for porridge and sugar. She did the same test again after 20 minutes. The results were given in the table below.

	Beginning		After 20 minutes	
	Porridge	Sugar	Porridge	Sugar
Water in the beaker	X	X	X	√
Solution in the tubing	√	X	X	√

- (a) What part of the human body did the water in the beaker represent? [1]

- (b) Based on this experiment and your answer in (a), what is its function with reference to the human body? [1]

- (c) Which part of the digestive system does the tubing represent? [1]

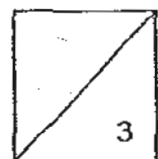

33. Jeffery's father, who was suffering from cancer, was advised by his doctor to have his large intestine removed to prevent the cancer cells from spreading. Jason is worried that his father will not be able to digest his food.

(a) Explain how the removal of his large intestine affect his digestion of food.

[1]

The diagram below shows 2 systems of his father's body.

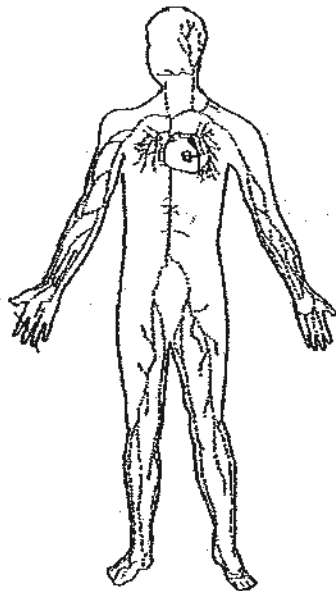

System A

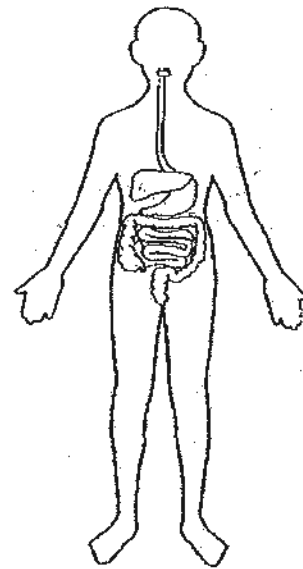

System B

(b) How do these systems work together for Jeffery's father?

[2]

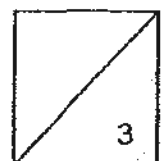

34. The table below shows statements about plant parts and their functions. Put a tick [✓] in the appropriate boxes. [2]

(a)

	True	False	Not possible to tell
Green leaves make food all day and night.			
The roots of a plant allow the plant to stand upright.			
The roots of a plant absorb water through the root hair.			
The leaves of a plant carry mineral salts to the rest of the plant.			

(b) State two functions of the stem. [2]

35. The diagram below shows the different stages of growth of a bean seed.

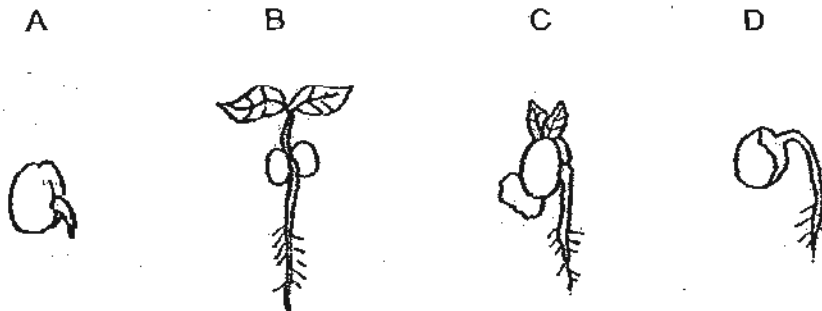

(a) Arrange the above diagram in the correct order of growth. [1]

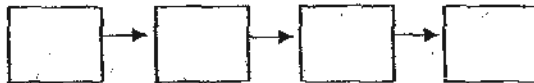

(b) Where does the seedling get its food before the shoot appears? [1]

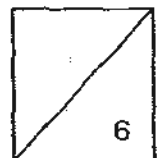

36. The diagrams below show the life cycles of a chicken and a frog.

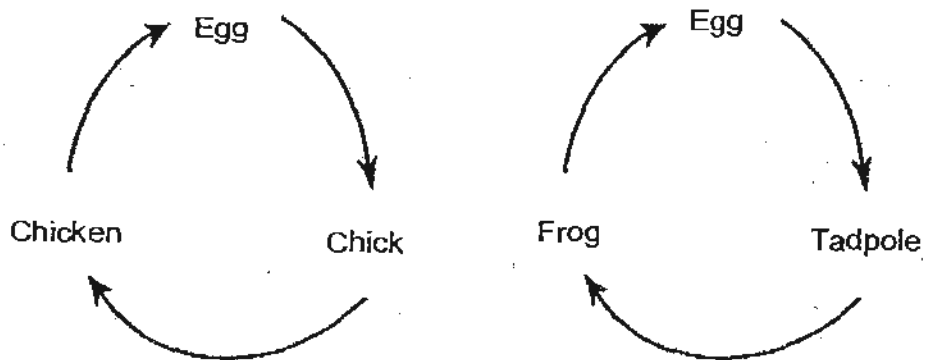

(a) State two similarities between the life cycles. [2]

- (i) _____

- (ii) _____

(b) Write down one difference between the life cycles. [1]

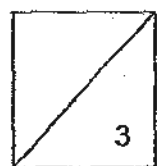

37. Zhenlong found some flies flying around an over-ripe banana. He kept the banana and some flies inside a large transparent container. He added a new banana every week and obtained the following observations.

	Flies	Eggs	Worm-like wriggling things
Day 1	5	3	0
Day 4	5	9	2
Day 7	3	0	8
Day 10	1	0	15
Day 13	0	0	15
Day 16	0	0	13
Day 19	0	0	11
Day 22	0	0	7
Day 25	0	0	0
Day 28	1	0	0
Day 31	3	5	0

Explain why

- (a) the flies decreased in number to 0 on Day 13. [1]

- (b) after Day 10, no eggs could be found on the banana until Day 31. [1]

- (c) flies appeared again on Day 28. [1]

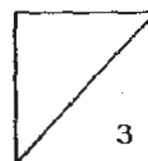

38. Part X of the spectacles shown below is made of glass.

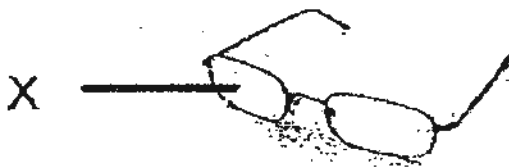

(a) Name another material that is suitable for making Part X. [1]

(b) What is the most important characteristic this material has which is similar to glass? [1]

(c) State one difference between the two materials. [1]

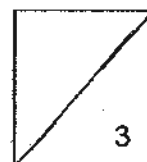

39. Study the classification chart below.

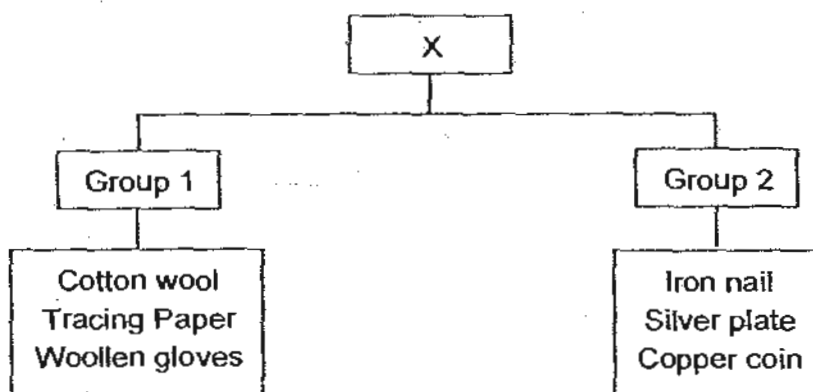

(a) What is the heading, X?

[1]

Peter and Sulin grouped aluminium foil and the ceramic plate differently in the classification chart above.

	Group 1	Group 2
Peter	Aluminium foil	Ceramic plate
Sulin	Ceramic plate	Aluminium foil

(b) What do you think are the subheadings that Peter and Sulin have chosen for Group 1 and Group 2? [2]

	Group 1	Group 2
Peter	_____	_____
Sulin	_____	_____

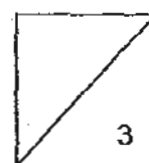

40. Study the diagram below carefully. Samantha wanted to take out the nails out of the container without getting her hands oily.

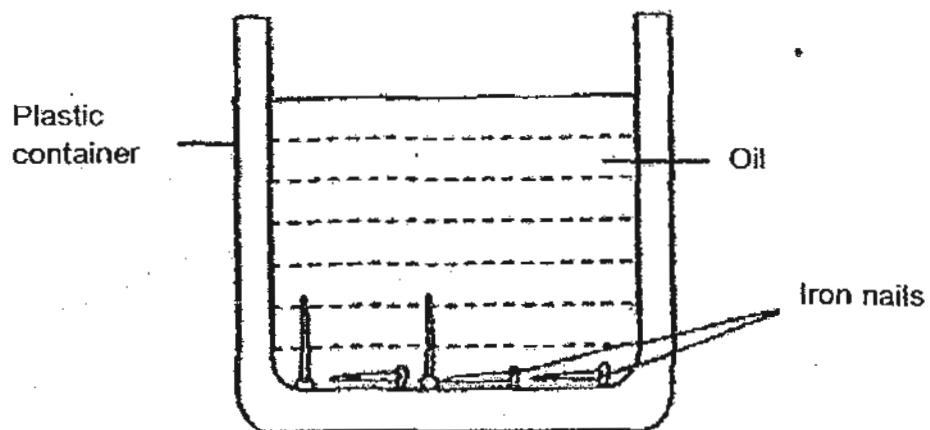

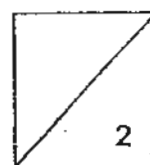

- (a) What can she use to take the nails out? [1]

- (b) Explain why she is able to take out the nails using the object in (a). [1]

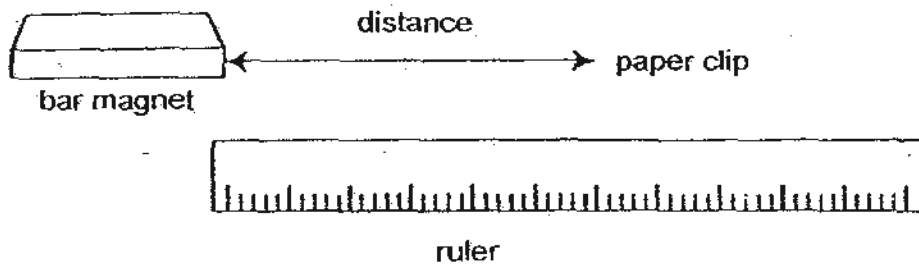

41. A paper clip is pushed towards a bar magnet slowly. The distance at which the paper clip is attracted to the magnet is measured. Then the bar magnet is replaced with another bar magnet of a different size before the process is repeated. The results are recorded in the table below.

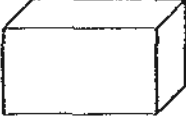

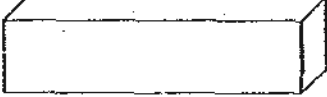
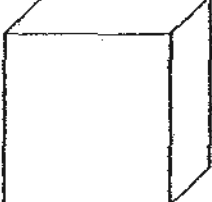
	Magnet	Distance/cm
A		3
B		2
C		1
D		4
E		3

(a) What do you think is the aim of the experiment?

[1]

(b) Compare the size and strength of magnets A and B.

[1]

(c) What can you conclude from the experiment?

[1]

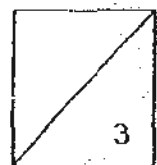

42. The diagrams below showed two containers, A and B containing fine sand and marbles respectively.

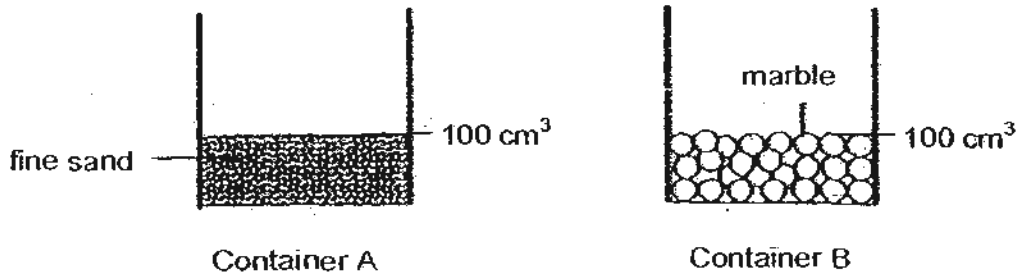

Xiaohui poured the sand from Container A into Container B. What is most likely to be the total volume of the sand and the marble?

Please tick () the correct box below.

[1]

(a)

<input type="checkbox"/>	Equal to 200 cm ³
<input type="checkbox"/>	Less than 200 cm ³
<input type="checkbox"/>	More than 200 cm ³

(b) Give a reason for your answer.

[1]

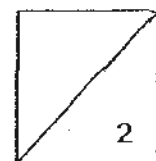

12

43. Shaun placed a pot of soil into a fish tank filled with water as shown in the set up below.

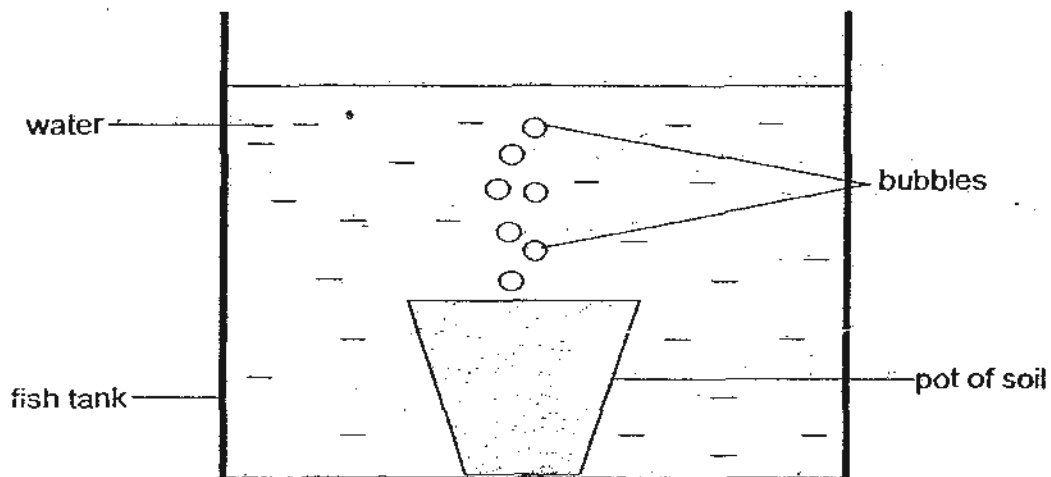

- (a) Why did the bubbles appear when the pot of soil is placed in the fish tank filled with water? [2]

- (b) What can he conclude from this experiment? [1]

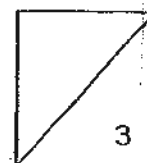

44. Ali moulded a piece of plasticine into a sphere, a pyramid and a cube as shown below, one at a time. He measured the mass and volume of each shape.

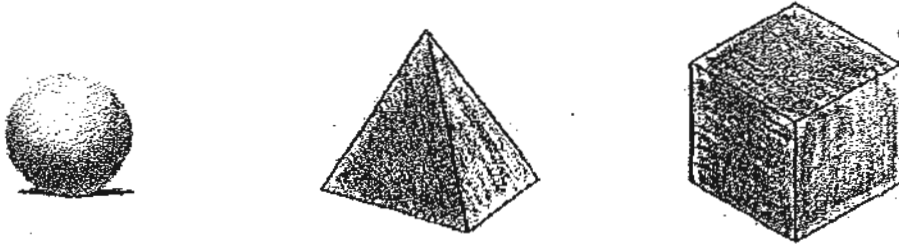

Ali made the following statements.

- X Plasticine can be compressed.
- Y The masses and volumes of the sphere, pyramid and cube are similar.

- (a) Which one of Ali's statements is wrong? [1]

- (b) Explain your answer in (a). [2]

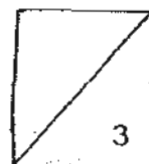

ANSWER SHEET

EXAM PAPER 2010

SCHOOL : CATHOLIC HIGH PRIMARY
SUBJECT : PRIMARY 4 SCIENCE

TERM : SA1

Q1	Q2	Q3	Q4	Q5	Q6	Q7	Q8	Q9	Q10	Q11	Q12	Q13	Q14	Q15	Q16	Q17
4	3	2	2	3	2	4	2	4	3	1	1	1	3	2	1	3

Q18	Q19	Q20	Q21	Q22	Q23	Q24	Q25	Q26	Q27	Q28	Q29	Q30
3	4	2	4	2	4	2	1	1	2	4	2	1

- 31)a)No. Whale is a mammal, while the shark is a fish. A shark lays eggs while a whale gives birth to young alive. A whale has but a shark has no hair.
b)This is to ensure that some of their eggs will be fertilized and become adult fish so that their kind will not become extinct.

- 32)a)Blood stream or blood.
b)It transports digested food to all parts of the body.
c)Small intestine.

- 33)a)It would not affect his digestion of food.
b)In the digestive system, digestion is completed in the small intestine where the digested food is absorbed. The circulatory system will carry the digested food to other of the body.

- 34)a)F F T F
b)The stem carries water from the roots to the leaves and other parts of the plant. The stem holds the branches in leaves in the best position to get the most sunlight.

- 35)a)A→D→C→B
b)The seedling gets its food from the seed leaves.

- 36)a)i)They have 3 stages. ii)They grow from eggs.
b)The tadpole looks different from its adult but the chick looks like its adult.

- 37)a)The flies grew old and died.
b)After Day 10, the flies had died while the other eggs had hatched into maggots after Day 4. on Day 31, the new adult files lay eggs again.
c)On Day 28, the pupae changed to adult files.

38)a)Plastic.

b)Plastic is transparent.

c)Glass break easily, while plastic does not.

39)a)Materials.

b)Peter : flexible / stiff

Sulin : non-metals / metals

40)a)A magnet.

b)Magnetic force can pass through plastic and oil.

41)a)It is to find out if the size of a magnet affects its strength.

b)Magnet A is smaller than magnet B but magnet A is stronger than magnet B.

42)a)Less than 200cm³

b)The fine sand will fill up the empty spaces between the marbles.

43)a)There is air trapped in the pot of soil. When the pot of soil is placed in the fish tank filled with water, the air trapped in the oil will escape as bubbles because water takes its space.

b)Air occupies space.

44)a)X.

b)The plasticine cannot be compressed because it is solid and solid has definite volume.