

Name: _____ ()

Class: Primary 4 _____

CHIJ ST NICHOLAS GIRLS' SCHOOL (Primary)



Primary 4 2010 First Semestral Assessment SCIENCE

BOOKLET A

12 May 2010

Total Time for Booklets A and B: 1 h 45 min

30 questions
60 marks

Do not open this booklet until you are told to do so.
Follow all instructions carefully.
Answer all questions.

Parent's Signature / Date

This paper consists of 16 printed pages.

4044

Section A : (30 x 2 marks)

For each question from 1 to 30, four options are given. One of them is the correct answer. Make your choice (1, 2, 3 or 4). Shade the correct oval (1, 2, 3 or 4) on the Optical Answer Sheet provided.

1. Which one of the following statements is correct?
- (1) The beetle has a 3-stage life cycle.
 - (2) The mosquito has a similar life cycle as a cockroach.
 - (3) The young of a cockroach moults several times as they grow.
 - (4) The young of a grasshopper changes into a pupa before becoming an adult.

2. Which one of the following diagrams shows the correct life cycle of a butterfly?

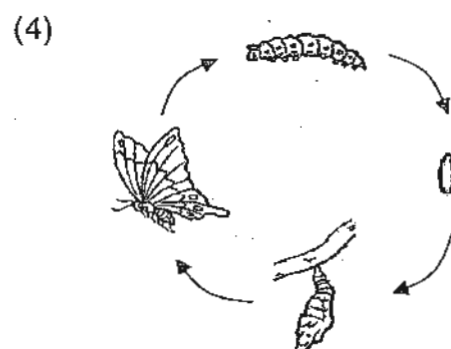
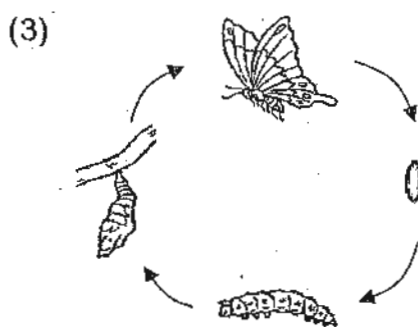
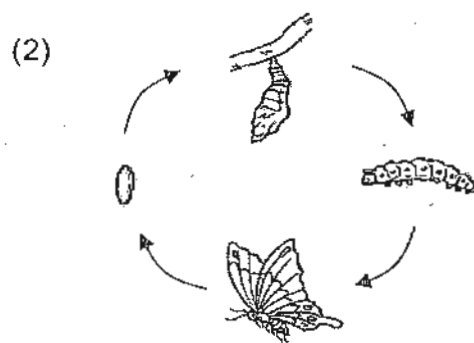
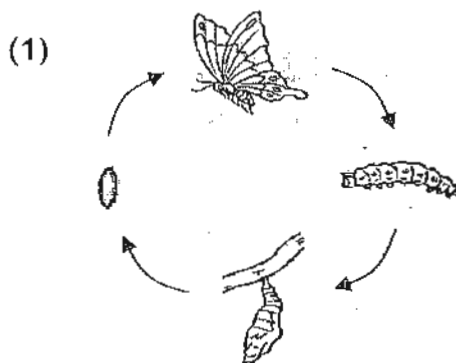

3. Which of the following statements are true about animals?
- A All animals go through a 3-stage life cycle.
 - B Some animals do not take care of their young.
 - C Some animals have young that look different from their parents.
 - D All animals can reproduce and have young while they are alive.

- (1) A and B only
- (2) C and D only
- (3) A, B and C only
- (4) B, C and D only

4. Michael did a study on the life cycle of three animals, X, Y and Z. He drew a checklist and placed a tick (✓) in the box if the characteristic is observed.

Observation	Animal X	Animal Y	Animal Z
It lays eggs in water.	✓		✓
There are 3 stages in the life cycle.	✓		
It has wings.		✓	✓
The young moult several times as they grow.		✓	

Which one of the following shows the animals with the correct characteristics described in the table above?

	Animal X	Animal Y	Animal Z
(1)	mosquito	frog	housefly
(2)	frog	dragonfly	beetle
(3)	housefly	beetle	grasshopper
(4)	frog	butterfly	mosquito

5. Study the flow chart below carefully.

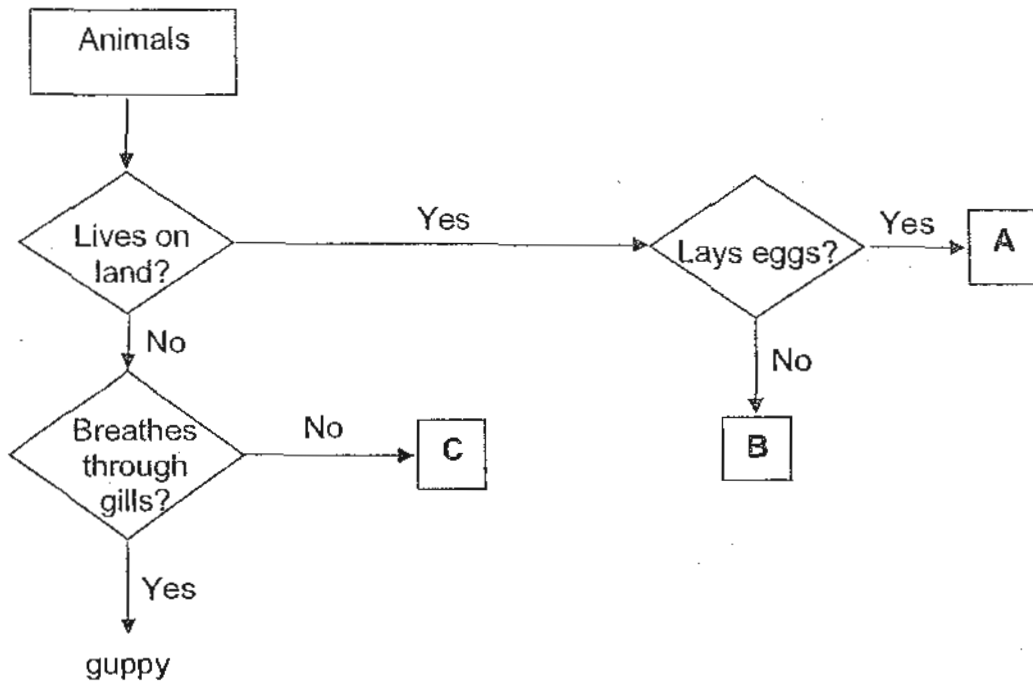

Which one of the following best represents animals A, B and C?

	A	B	C
(1)	grasshopper	monkey	swordtail
(2)	frog	platypus	goldfish
(3)	platypus	tiger	frog
(4)	butterfly	deer	shark

6. The diagrams below show the life cycle of a mosquito and a chicken.

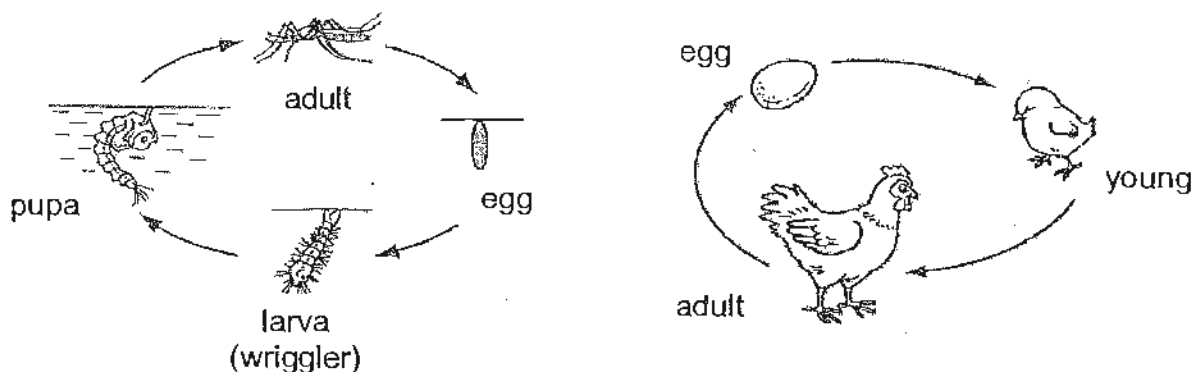

Which one of the following statements describes the two life cycles incorrectly?

- (1) The chick can reproduce but the larva cannot.
- (2) The larva turns into a pupa before becoming an adult mosquito.
- (3) The chick resembles its parent but the larva does not resemble its parent.
- (4) The mosquito has a 4-stage life cycle but the chicken has a 3-stage life cycle.

7. Some materials are classified as shown in the table below. Which pair is incorrect?

	Non-magnetic	Magnetic
(1)	Clay	Steel
(2)	Ceramic	Iron
(3)	Aluminium	Copper
(4)	Bronze	Steel

8. Which of the following are not uses of magnets?

- A To separate diamond from gold
- B To be used in a camera to take photograph
- C To be used in a compass to show directions
- D To keep the doors of refrigerator tightly closed

- (1) A and B only
- (2) C and D only
- (3) A, B and C only
- (4) B, C and D only

9. Which of the following actions will cause a magnet to lose its magnetism?

- A Heating it repeatedly over a flame
- B Dropping it many times on the floor
- C Hitting it many times with a hammer
- D Using it many times to pick up magnetic objects

- (1) A and B only
- (2) C and D only
- (3) A, B and C only
- (4) B, C and D only

10. In which one of the following set-ups will the rod become an electromagnet?

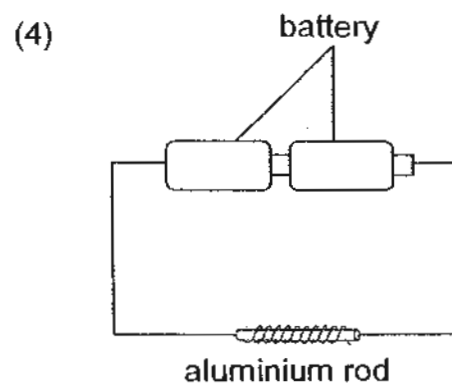
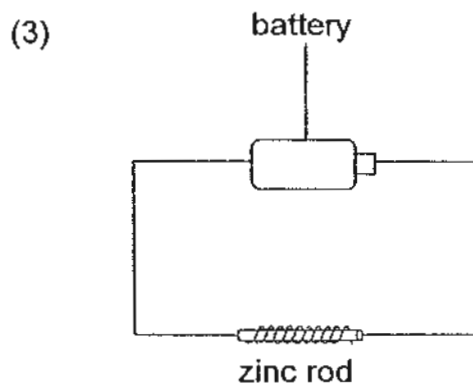
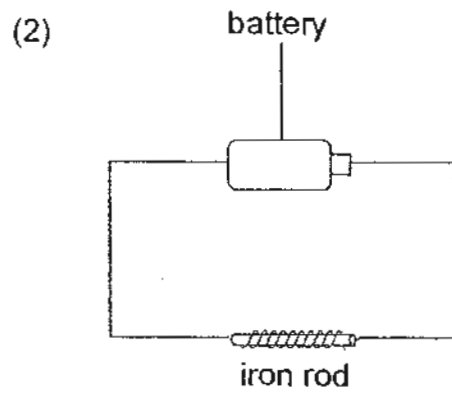
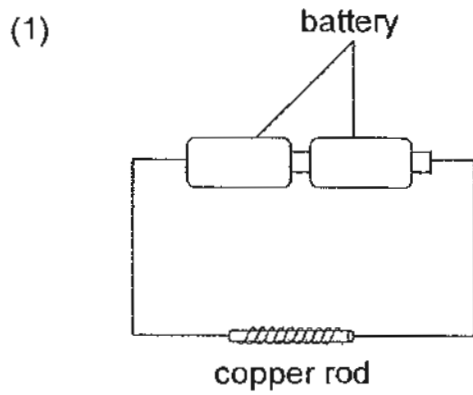

11. Alex sprinkles some iron filings around a bar magnet. Which one of the following diagrams correctly shows the pattern of the iron filings around the magnet?

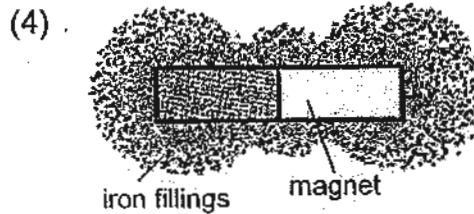
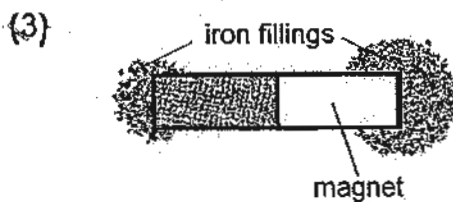
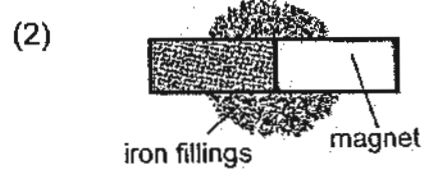
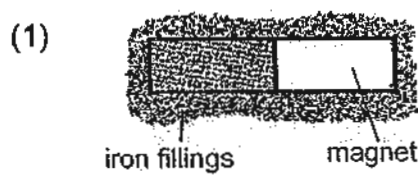

12. Jolene suspended 4 magnets as shown in the diagram below.

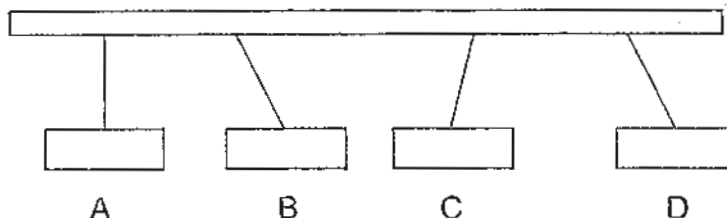

Which of the following are **definitely** magnets?

- (1) B only
- (2) B and C only
- (3) C and D only
- (4) A, B and C only

13. In diagram 1 below, magnet P is hung from a spring with magnet Q placed under it. Diagram 2 shows the length of the spring after magnet Q is removed.

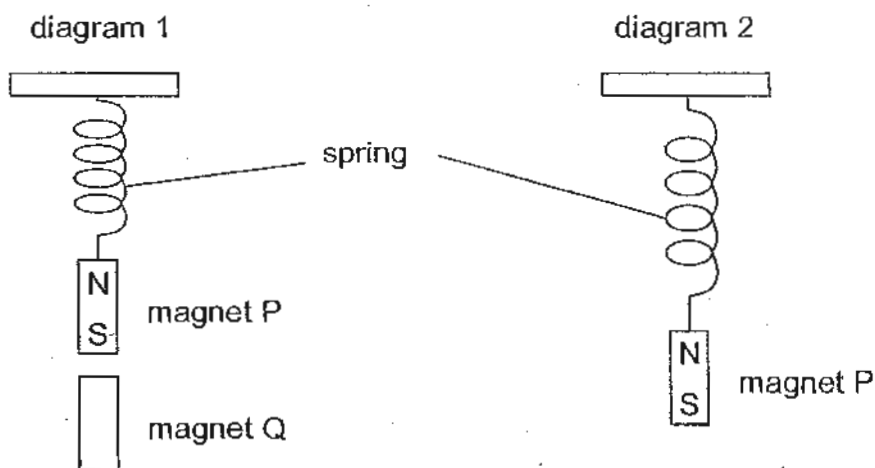

Which one of the following statements explains the change in the length of the spring as shown in diagram 2?

- (1) The spring has loosened.
- (2) Magnet P has become heavier.
- (3) Magnet P has become stronger in strength.
- (4) Magnet Q no longer exerts a force to repel Magnet P.

14. Three bar magnets are placed next to one another. Which of the following arrangements are possible?



(A)

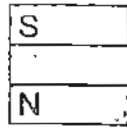

(B)

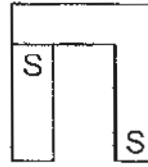

(C)

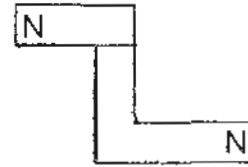

(D)

- (1) A and C only
 (2) B and D only
 (3) A, B and C only
 (4) B, C and D only

15. Sally made an electromagnet using an iron nail, a battery and some wires as shown below.

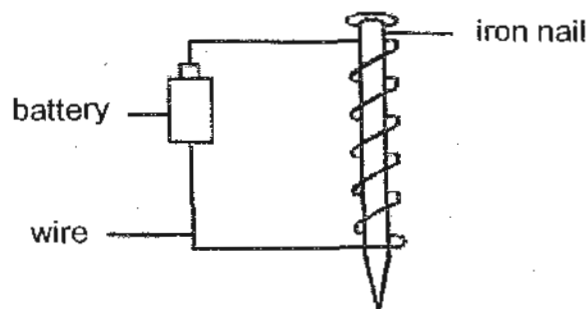

What can Sally do to increase the strength of her electromagnet?

- A Increase the length of the wire used
 B Increase the number of batteries used
 C Increase the thickness of the wire used
 D Increase the number of turns of wire around the iron nail
- (1) A and C only
 (2) B and D only
 (3) A, B and D only
 (4) A, B, C and D

16. In diagram 1 shown below, an iron nail is made into a temporary magnet using the stroking method. The magnetised nail is then placed next to a compass X as shown in diagram 2.

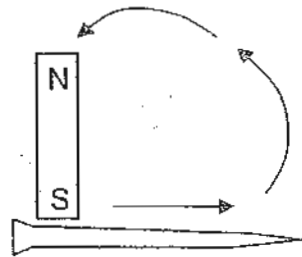

diagram 1

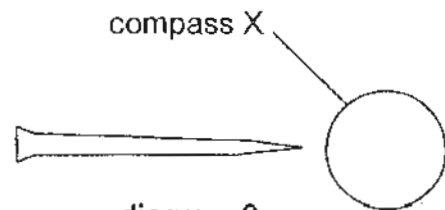
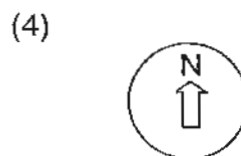
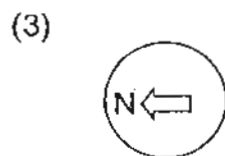
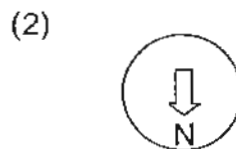
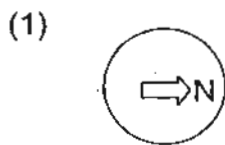

diagram 2

Which one of the following compasses correctly represents compass X in the above set-up?



17. The amount of matter in an object is called its _____.

- (1) mass
- (2) weight
- (3) volume
- (4) substance

18. Which of the following items can be classified as matter?

- A Oil
- B Soil
- C Shadow
- D Sunlight

- (1) A and B only
- (2) B and D only
- (3) A, C and D only
- (4) A, B, C and D

19. Siti compared the mass of three balls, S, T and U, by using a simple balance. The results as shown in the diagrams below.

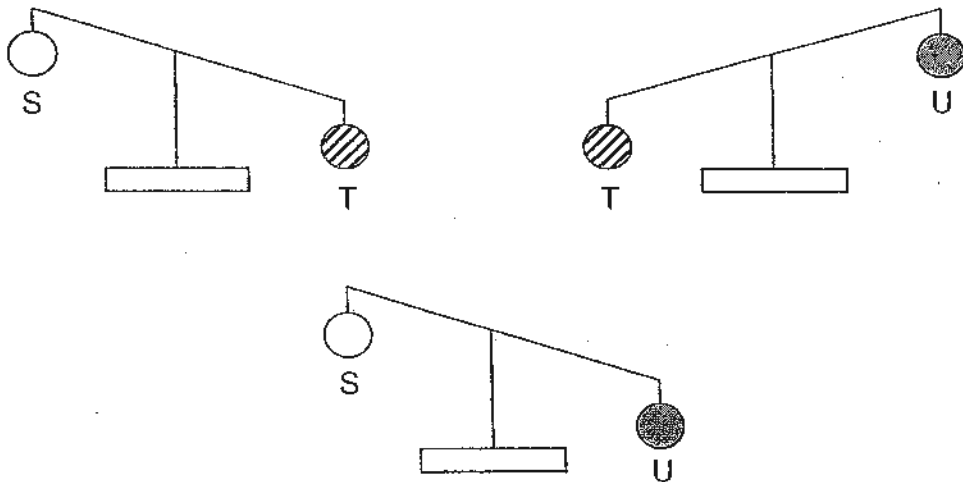

Which one of the following arrangements shows the mass of the three balls in descending order?

- (1) T, S, U
- (2) S, U, T
- (3) T, U, S
- (4) U, T, S

20. In an experiment, Jason filled a container with water till its spout as shown in the Figure 1. Next, when he lowered a stone into the container, some water overflowed into a beaker as shown in Figure 2.

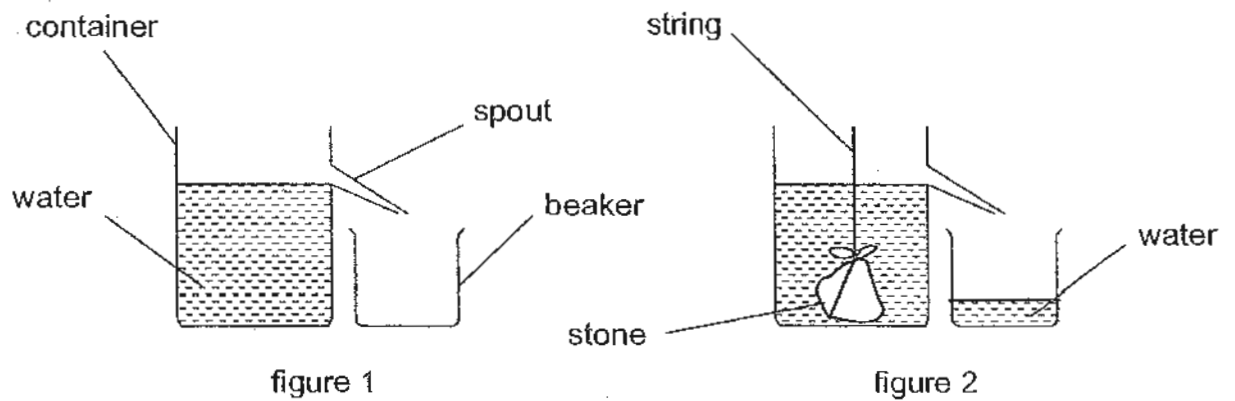

What does the water collected in the beaker represent?

- (1) Mass of the stone
 - (2) Volume of the stone
 - (3) Total volume of all the water
 - (4) Mass and volume of the stone
21. Which of the following pairs of substances are similar in state?
- (1) Ice and water
 - (2) Rice and soup
 - (3) Sugar and salt
 - (4) Book and coffee
22. Which one of the following groups of matters has a definite volume but no definite shape?
- (1) Key chain and smoke
 - (2) Cooking oil and rain water
 - (3) Orange juice and alarm clock
 - (4) Sea water and carbon dioxide

23. In an experiment, Mei Lin poured some substance Y into a rectangular container. She then placed the container in different positions as shown below and observed the behaviour of substance Y.

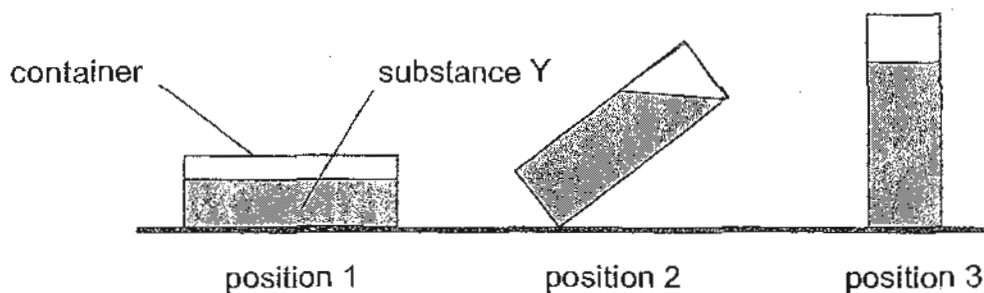

At the end of the experiment, she wrote down four statements describing her observations.

- A Substance Y takes up space.
- B Substance Y can be compressed.
- C Substance Y does not have a definite mass.
- D Substance Y does not have a definite shape.

Which of her statements is/are **not** based on her observations?

- (1) A only
- (2) C only
- (3) A and D only
- (4) B and C only

24. The table below shows the properties of some matters. Which one of the matters is correctly described?

	Type of matter	Has a definite shape?	Has a definite volume?	Occupies space?	Can be compressed?
(1)	Nitrogen	No	Yes	No	Yes
(2)	Plasticine	No	Yes	Yes	Yes
(3)	Fruit juice	No	Yes	Yes	No
(4)	Cotton wool	No	No	Yes	Yes

25. Agnes observed a matter that went through some changes in state and wrote down the property of the matter at each stage.

Stage 1 : Definite volume but no definite shape.

Stage 2 : No definite volume or shape.

Stage 3 : Definite volume but no definite shape.

Stage 4 : Definite volume and shape.

Which one of the following shows the changes of state correctly?

- (1) Ice \rightarrow water \rightarrow ice \rightarrow water vapour
(2) Water \rightarrow water vapour \rightarrow water \rightarrow ice
(3) Water \rightarrow ice \rightarrow water \rightarrow water vapour
(4) Water vapour \rightarrow water \rightarrow water vapour \rightarrow ice
26. Guo Qiang used a light sensor and a data logger to find out how much light passes through four sheets, A, B, C and D, each made of a different material. He plotted the results in the graph shown below.

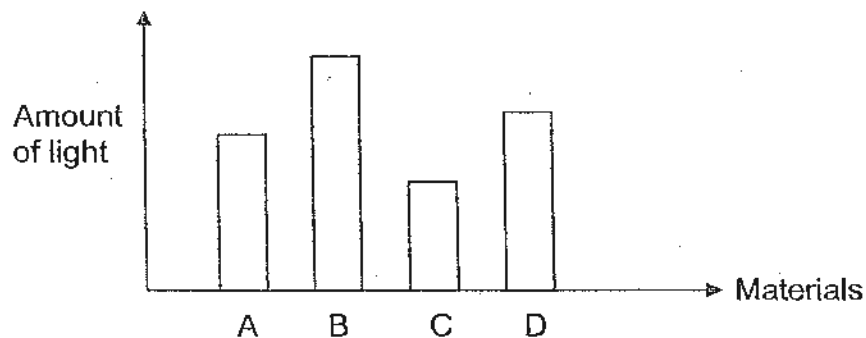

Which one of the sheets would cast the **darkest** shadow when light is shone on it?

- 1) A
2) B
3) C
4) D

27. Which one of the following pairs of items allows only some light to pass through them?

- 1) Car tyre and frosted glass
- 2) Tracing paper and whiteboard
- 3) Clear plastic and tracing paper
- 4) Frosted glass and tracing paper

28. Which one of the following graphs shows the length of the shadow cast by a flag pole from 8 a.m. to 6 p.m. on a certain sunny day?

(1)

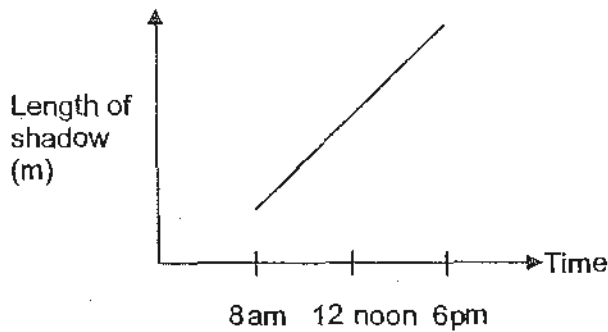

(2)

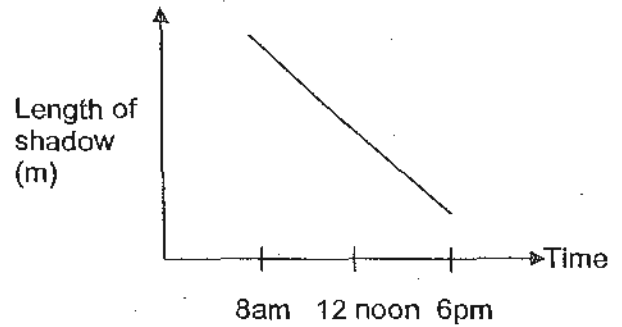

(3)

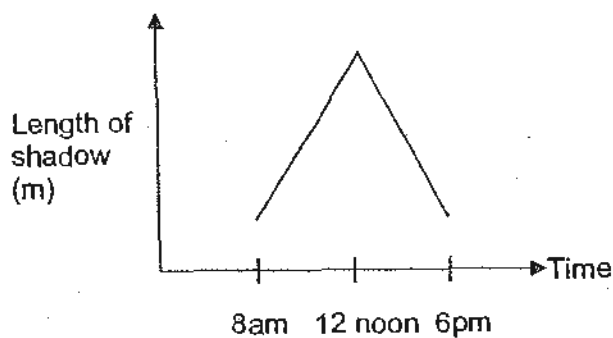

(4)

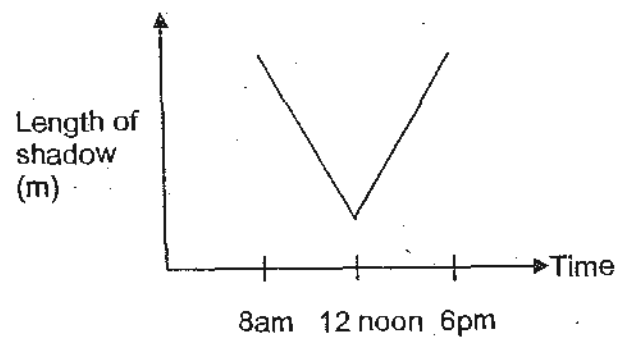

29. Which property of light causes shadows to be formed?

- (1) Light can be reflected.
- (2) Light is a form of energy.
- (3) Light travels in a straight line.
- (4) Light enables us to see things.

30. The experiment shown below was carried out in a dark room. Sheet X, Y and Z are arranged in a straight line. When a torch is shone at the hole, a bright triangular patch of light is seen on sheet Z only.

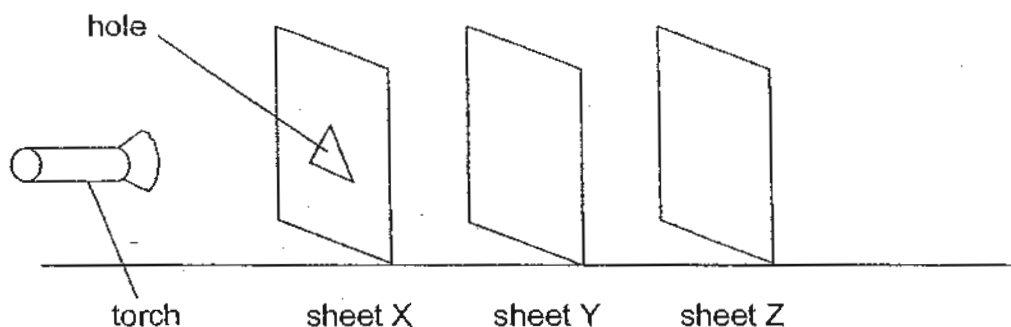

Which one of the following lists shows the correct material used for sheet X, Y and Z respectively?

	Sheet X	Sheet Y	Sheet Z
(1)	styrofoam	wood	clear glass
(2)	wood	clear glass	cardboard
(3)	clear glass	styrofoam	wood
(4)	cardboard	wood	clear glass

~~~~~ END OF SECTION A ~~~~~

Name: \_\_\_\_\_ ( )

Class: Primary 4 \_\_\_\_\_

## CHIJ ST NICHOLAS GIRLS' SCHOOL (Primary)



### Primary 4 2010 First Semestral Assessment SCIENCE

BOOKLET B

12 May 2010

Total Time for Booklets A and B: 1 h 45 min

14 questions  
40 marks

Do not open this booklet until you are told to do so.  
Follow all instructions carefully.  
Answer all questions.

|           |     |
|-----------|-----|
| Booklet A | 60  |
| Booklet B | 40  |
| Total     | 100 |

\_\_\_\_\_  
Parent's Signature / Date

This paper consists of 13 printed pages.

**Section B: 40 marks**

For questions 31 to 44, write your answers in this booklet.

The number of marks available is shown in the brackets [ ] at the end of each question or part question.

---

31. The pictures below show a frog and a cockroach.



frog



cockroach

a) What are the young of these animals called?

[1]

(i) Young of a frog : \_\_\_\_\_

(ii) Young of a cockroach : \_\_\_\_\_

b) State two differences between the young of the frog and the cockroach. [2]

(Do not compare the size, shape, colour, food and habitat.)

(i) \_\_\_\_\_

\_\_\_\_\_

(ii) \_\_\_\_\_

\_\_\_\_\_

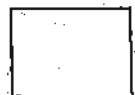

32. The statements below describe the 4 different stages in the life cycle of an animal.

Stage A : Emerges with wings

Stage B : Eats the leaves around it

Stage C : Attaches on the underside of leaves in great numbers

Stage D : Attaches upside down on a twig without any visible activity

a) Based on the statements above, write letters A, B, C and D, to complete the life cycle of the animal below. [2]

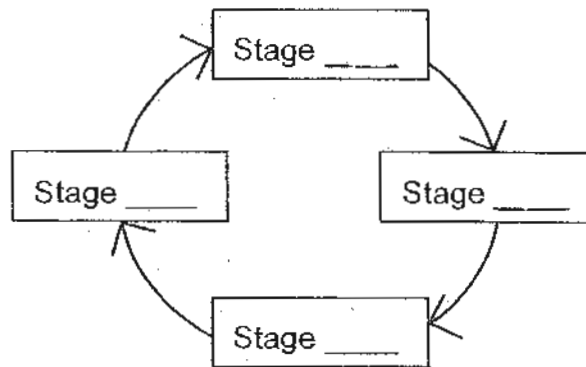

b) Name the animal whose life cycle has been described above. [1]

\_\_\_\_\_

33. State whether each of the following statements is true (T), false (F) or not possible to tell (NP). Write your answers in the boxes provided. [4]

|    |                                                                             |  |
|----|-----------------------------------------------------------------------------|--|
| a) | Insects may have a three-stage or a four-stage life cycle.                  |  |
| b) | Some living things look very similar at various stages in their life cycle. |  |
| c) | All animals have the same life span.                                        |  |
| d) | Organism X has a 3-stage life cycle, therefore, it is a mammal.             |  |

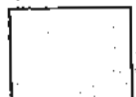

34. Study the classification chart below carefully.

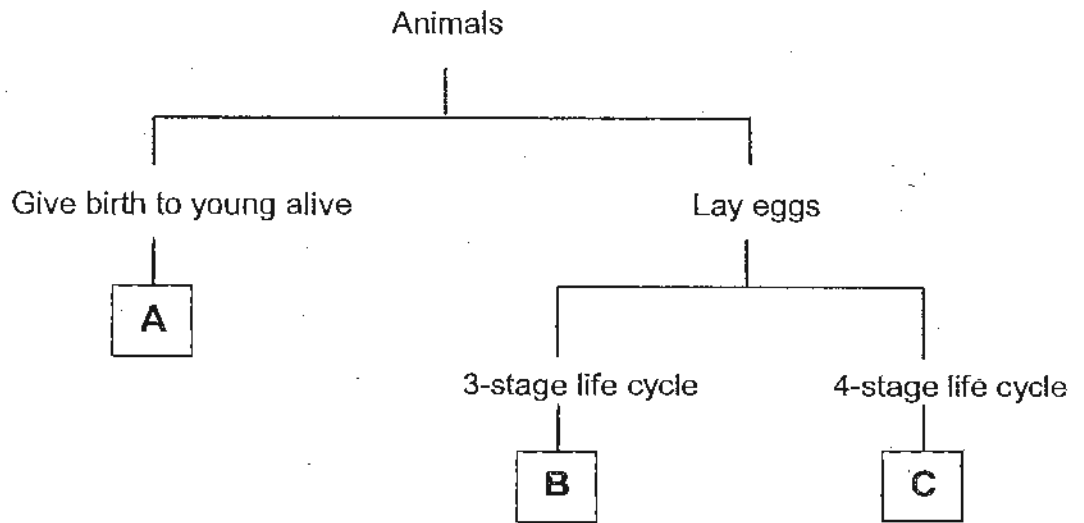

a) List the characteristics of animal C. [1]

---

---

b) What is the difference in the life cycle between animal A and B? [1]

---

---

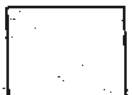

35. Ting Ting took an empty plastic cup, inverted it and pushed it into a basin of water as shown in diagram A. She then used a pin to pierce a hole at the side of the cup as shown in the diagram B below.

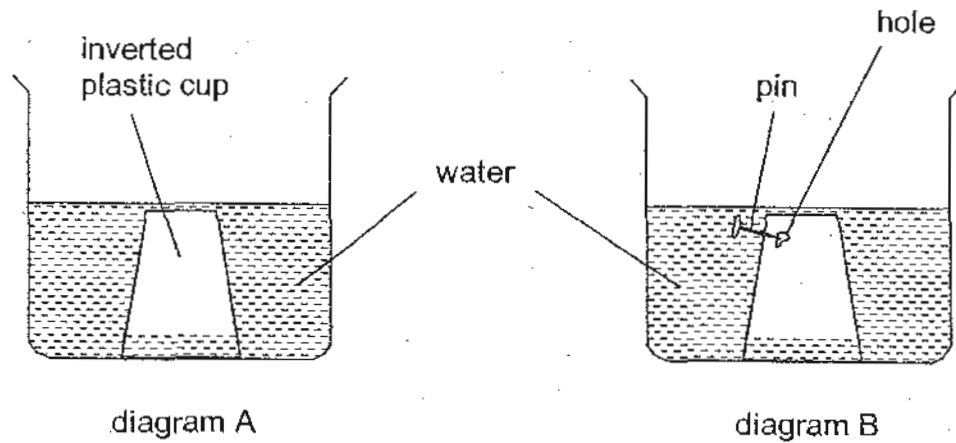

- a) Explain why the water in the basin did not fill the inverted plastic cup in diagram A. [2]

---

---

- b) What would Ting Ting observe after she had pierced the hole in the plastic cup in diagram B? [2]

---

---

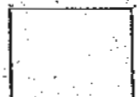

36. In an experiment, Kelly covered the tip of an empty syringe with her finger and tried to push the plunger.

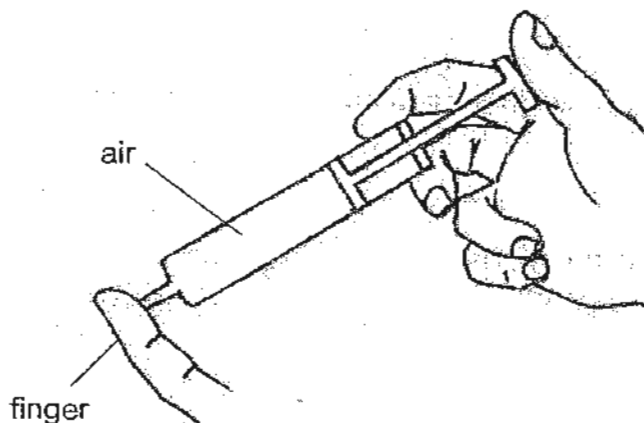

- a) Describe what Kelly will observe about the plunger. [1]

---

- b) What does this experiment show about the property of air? [1]

---

- c) State one similarity in property between a liquid and a gas. [1]

---

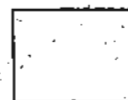

37. The table below shows the properties of 4 different items.

| Item | Occupies space? | Has a definite shape? | Can be compressed? |
|------|-----------------|-----------------------|--------------------|
| P    | Yes             | No                    | Yes                |
| Q    | No              | No                    | No                 |
| R    | Yes             | Yes                   | No                 |
| S    | Yes             | No                    | No                 |

Answer the following questions based on the information given above. Write your answers, P, Q, R or S, in the space provided. [3]

|    |                                      |  |
|----|--------------------------------------|--|
| a) | Which item could be a liquid?        |  |
| b) | Name the item that is not a matter.  |  |
| c) | Name one item that could be a solid. |  |



38. The box below shows 4 different objects.

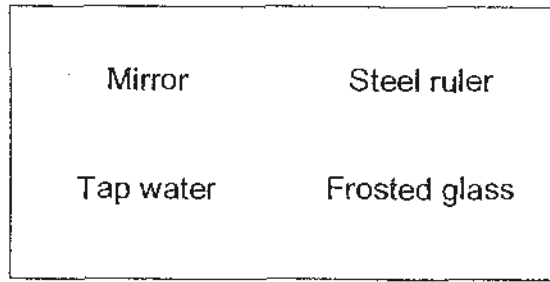

a) Classify the objects listed in the box above into the correct groups, A, B and C, in the classification chart below. [2]

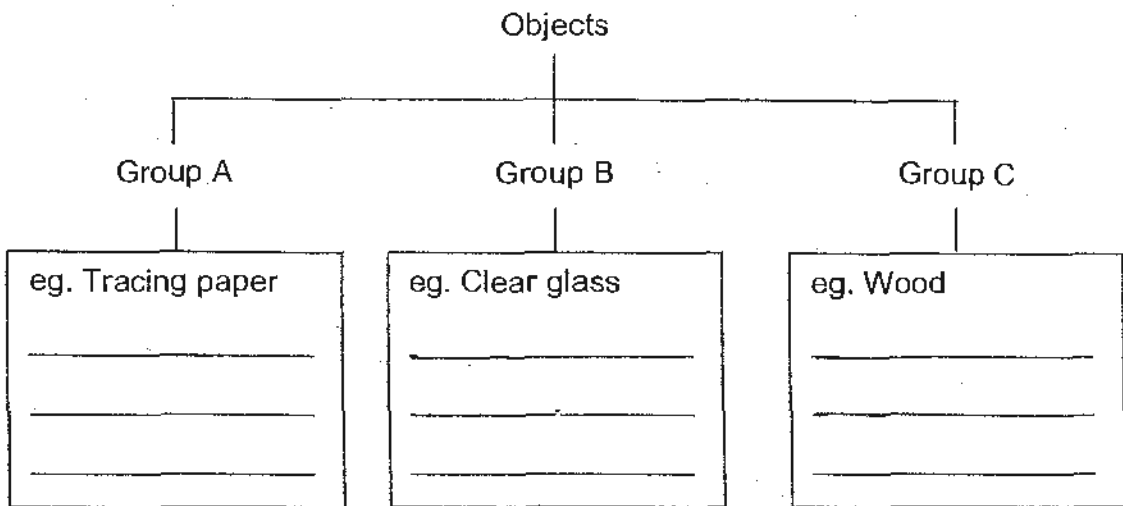

b) Give suitable headings for Group A and C: [2]

(i) Group A : \_\_\_\_\_

(ii) Group C : \_\_\_\_\_

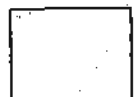

39. Mike tried to look at a candle flame using a flexible rubber hose as shown in the diagram below.

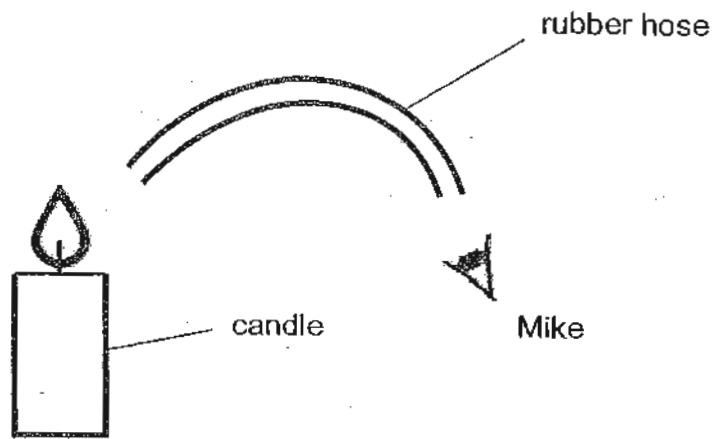

- a) Mike discovered that he was not able to see the candle flame. Explain why. [1]

---

---

- b) Without changing the object or adding other materials to the rubber hose, what could Mike do to his rubber hose so that he would be able to see the candle flame? [1]

---

---



40. Mary placed an apple in front of the wall of her bedroom. She shone a torch on the apple to create shadows of different sizes on the wall.

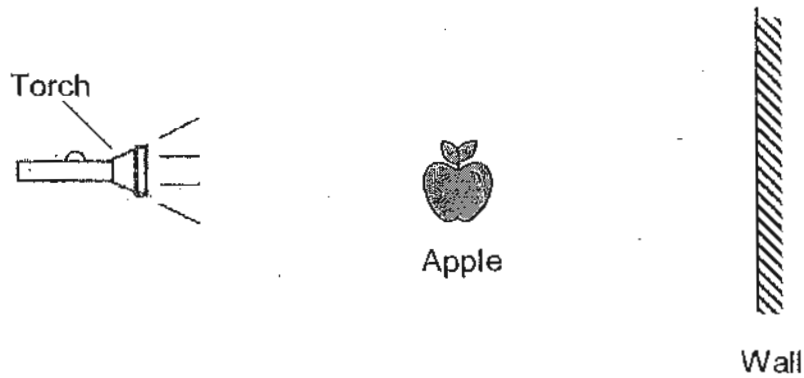

List 2 ways to show how <sup>Mary</sup> ~~Jessie~~ can create a bigger shadow on the wall. [2]

- (i) \_\_\_\_\_  
 \_\_\_\_\_
- (ii) \_\_\_\_\_  
 \_\_\_\_\_

41. The diagram below shows the positions of the Sun, the Earth and the Moon. The cross X on the Earth represents a person.

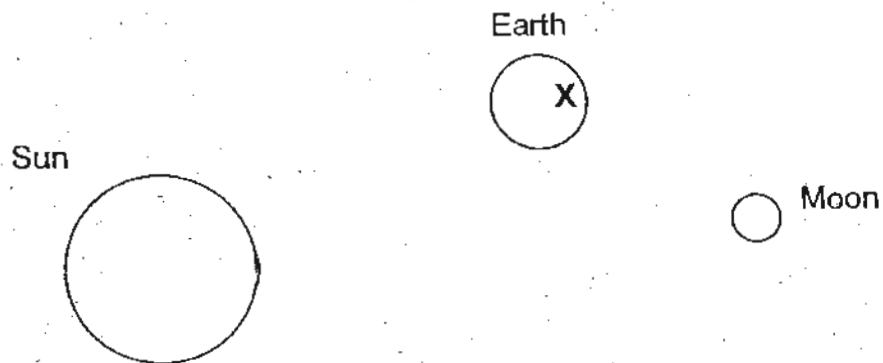

Draw arrows to show the path of light that allow us to see the moon although it is not a light source. [2]



42. Jonathan carried out an experiment using a magnet and three metal bars, **S**, **T** and **U**. He recorded his observations in the table below.

| Metal Bar | Observations                                                    |
|-----------|-----------------------------------------------------------------|
| <b>S</b>  | The bar is not attracted to or repelled by the magnet.          |
| <b>T</b>  | Both ends of the bar are attracted to the magnet.               |
| <b>U</b>  | The magnet attracts one end of the bar but repel the other end. |

Based on the observations, identify the type of metal bar, **S**, **T** and **U**, by writing the letters in the space provided. [3]

A magnet : \_\_\_\_\_

A magnetic object : \_\_\_\_\_

A non-magnetic object : \_\_\_\_\_

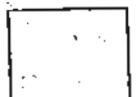

43. Shafik set up an experiment as shown below to find out the effect of magnetic force passing through different materials.

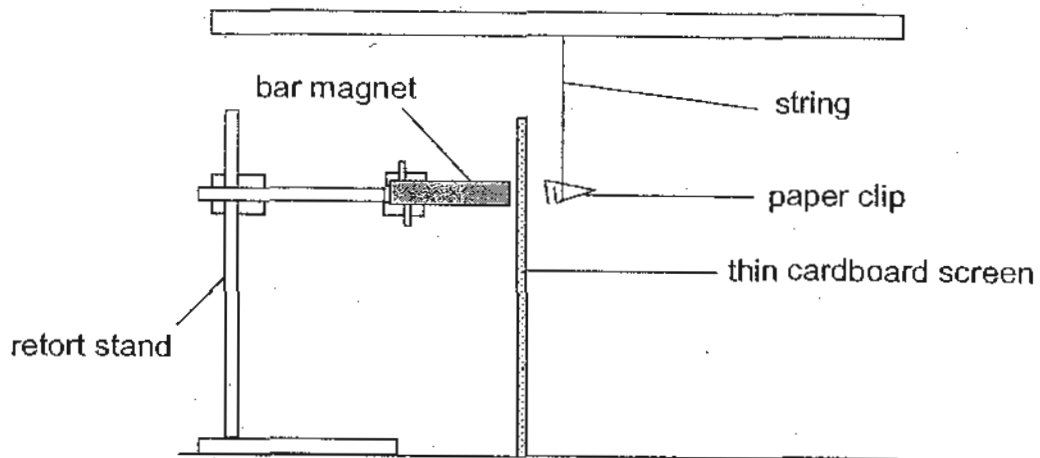

- a) What will happen to the paper clip when the bar magnet is brought close to the thin cardboard screen as shown in the diagram above? [1]

---

---

- b) In the next set-up, Shafik replaces the cardboard screen with an iron screen. Explain what will happen to the paper clip. [1]

---

---



44. Sammy's teacher challenged him to remove a paper clip out of his shirt pocket without touching it with his hands. However, Sammy may use any of the following items that were given to him:

- A bar magnet
- A handkerchief
- A compass

a) Which item should Sammy use? [1]

---

b) Describe what he would do to accomplish the task. [2]

---

---

---

~~~~ End of Paper ~~~~



ANSWER SHEET

EXAM PAPER 2010

SCHOOL : CHIJ ST NICHOLAS GIRLS' SCHOOL

SUBJECT : PRIMARY 4 SCIENCE

TERM : SEMESTRAL ASSESSMENT 1

| | | | | | | | | | | | | | | | | |
|----|----|----|----|----|----|----|----|----|-----|-----|-----|-----|-----|-----|-----|-----|
| Q1 | Q2 | Q3 | Q4 | Q5 | Q6 | Q7 | Q8 | Q9 | Q10 | Q11 | Q12 | Q13 | Q14 | Q15 | Q16 | Q17 |
| 3 | 3 | 4 | 4 | 3 | 1 | 3 | 1 | 3 | 2 | 4 | 3 | 4 | 1 | 2 | 1 | 1 |

| | | | | | | | | | | | | |
|-----|-----|-----|-----|-----|-----|-----|-----|-----|-----|-----|-----|-----|
| Q18 | Q19 | Q20 | Q21 | Q22 | Q23 | Q24 | Q25 | Q26 | Q27 | Q28 | Q29 | Q30 |
| 1 | 3 | 2 | 3 | 2 | 4 | 3 | 2 | 3 | 4 | 4 | 3 | 2 |

Q31ai) tadpole

ii) nymph

bi) The nymph represents its parent but the tadpole does not resemble its parent.

ii) The nymph moults but the tadpole does not moult.

Q32a)



b) Butterfly

Q33a) True

b) True

c) False

d) False

Q34a) Animal C lay eggs and has a 4-stage life cycle.

b) Animal A gives birth to its young alive but Animal B lays eggs.

Q35a) Air inside the plastic cup occupies space and it prevented the water from entering the plastic cup.

b) Air in the plastic cup would escape through the hole as air bubbles and water would enter the plastic cup to fill the space up to the hole.

Q36a) The plunger will be able to move a little distance into the syringe.

b) Air can be compressed.

c) Both of them do not have a definite shape.

- Q37a)S
 b)Q
 c)R

Q38a)

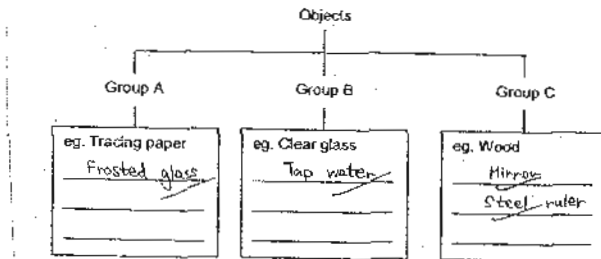

- Bi) Translucent things
 ii) Opaque things

- Q39a) Light travels in a straight line but the rubber hose is bent.
 b) Mike could stretch the rubber hose until it is straight.

- Q40i) Move the light source nearer to the object.
 ii) Move the object nearer to the light source.

Q41)

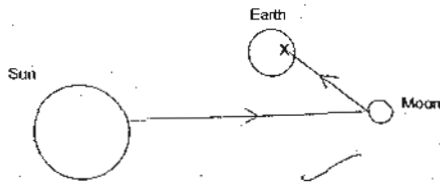

- Q42) A magnet: U
 A magnetic object: T
 A non-magnetic object: S

- Q43a) The paper clip will be attracted by the bar magnet.
 b) The paper clip will not move, because the magnetic force cannot pass through the iron screen.

- Q44a) A bar magnet.
 b) Sammy would first bring the magnet close to his shirt pocket until it is able to attract the paper clip. Then he would move the magnet slowly up his shirt pocket until the paper clip comes out.