

NANYANG PRIMARY SCHOOL

PRIMARY FOUR SCIENCE

**SEMESTRAL ASSESSMENT 2
2010**

BOOKLET A

Date : 29th October 2010

Duration : 1 h 45 min

Name : _____ ()

Class: Primary _____ ()

Marks Scored:

Booklet A:		60
Booklet B :		40
Total :		100

Parent's signature:

**DO NOT OPEN THIS BOOKLET UNTIL YOU ARE TOLD TO DO SO.
FOLLOW ALL INSTRUCTIONS CAREFULLY.**

Booklet A consists of 19 printed pages including this cover page.

Section A (30 x 2 marks = 60 marks)

For each question from 1 to 30, four options are given. One of them is the correct answer.

Make your choice (1, 2, 3 or 4). Shade the correct oval (1, 2, 3 or 4) on the Optical Answer Sheet provided.

1. Which one of the organisms shown below is **NOT** an insect?

(1)



(2)



(3)

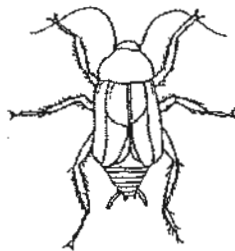

(4)

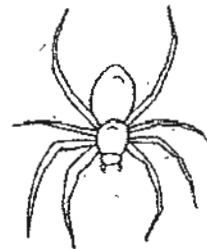

2. Alan can easily scratch a wooden stick with an iron nail.

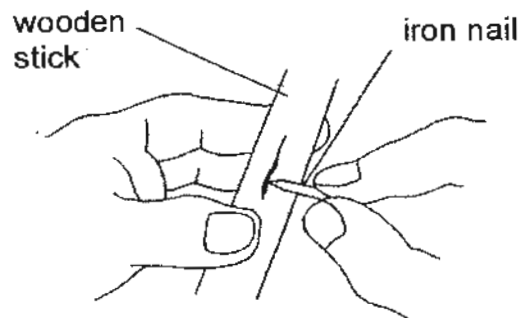

This shows that the iron nail is _____ than the wooden stick.

- (1) harder
- (2) heavier
- (3) more flexible
- (4) stronger

3. The diagram below shows the life cycle of an animal.

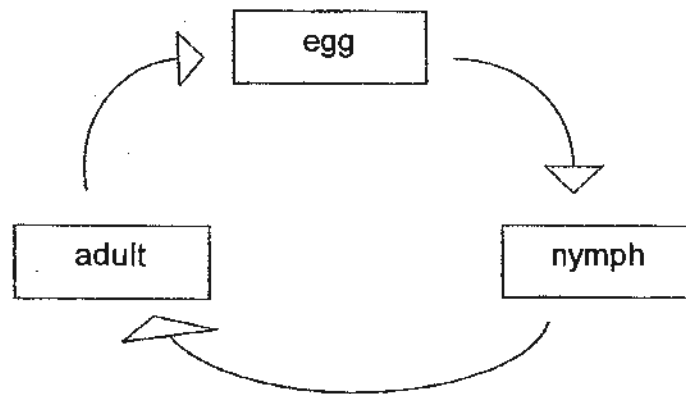

Which animal is likely to have the life cycle as shown above?

- ~~(1)~~ beetle
- ~~(2)~~ butterfly
- ~~(3)~~ chicken
- ~~(4)~~ cockroach

4. Which one of the following is true for both air and a pencil?

- ~~(1)~~ They can be seen.
- ~~(2)~~ They take up space.
- ~~(3)~~ They have fixed shapes.
- ~~(4)~~ They have fixed volumes.

5. Which one of the following is the function of a leaf on a plant?

- ~~(1)~~ makes food
- ~~(2)~~ takes in water
- ~~(3)~~ holds a plant upright
- ~~(4)~~ takes in mineral salts

6. What is the main function of the large intestine?

- ~~(1)~~ It removes digested food from the body.
- ~~(2)~~ It removes undigested food from the body.
- ~~(3)~~ It allows water to be passed into the blood.
- ~~(4)~~ It allows digested food to be passed into the blood.

7. Which one of the following can be attracted by a magnet?

- (1) Plastic ball
- (2) Rubber ball
- (3) Steel ball
- (4) Wooden ball

8. Look at the picture below.

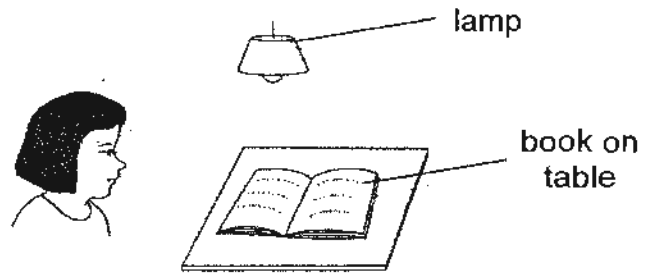

Which one of the following explains why Sue can see the book on the table?

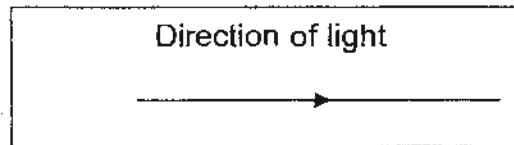

(1)

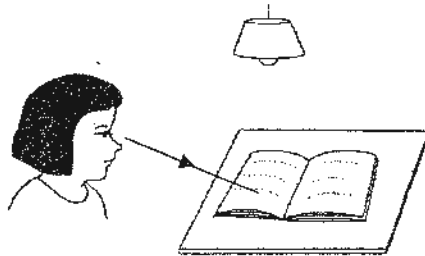

(2)

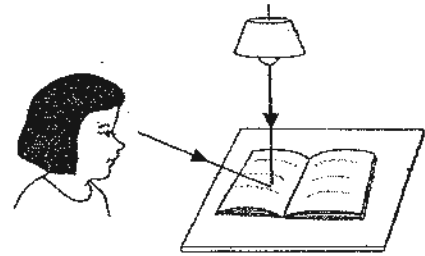

(3)

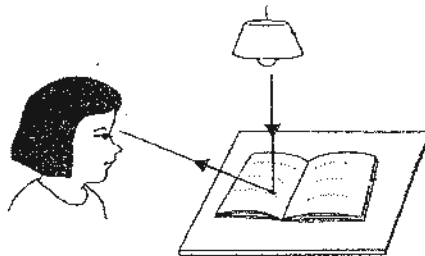

(4)

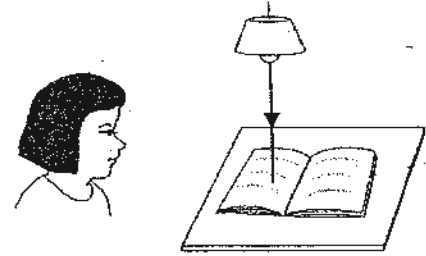

9. Karim places an ice cube into a glass of hot water.

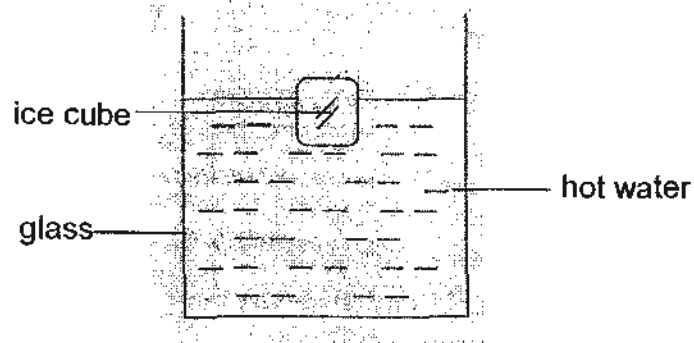

Which one of the following is correct?

- (1) The ice cube does not gain or lose heat.
- (2) The hot water loses heat to the ice cube.
- (3) The ice cube loses heat to the hot water.
- (4) The hot water gains heat from the ice cube.

10. Hashim boiled some water in the pot shown below.

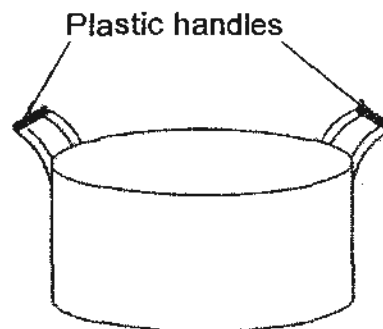

He is able to hold the pot of boiling water using the plastic handles.
This is because plastic is a _____.

- (1) light material
- (2) flexible material
- (3) poor conductor of heat
- (4) good conductor of heat

11. Solid X was placed in an enclosed container of oil and water. The result is shown below.

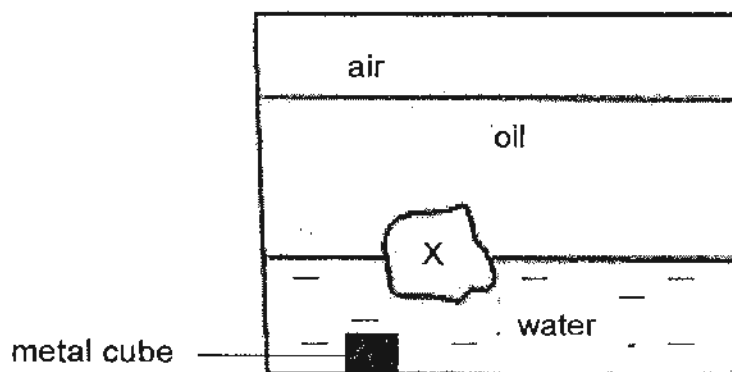

Which one of the following statements about the result of this experiment is **not** correct?

- (1) Oil floats on water.
- (2) Air floats on water.
- (3) Matter floats on water.
- (4) Solid X floats on water.

12. The table below shows the melting points and boiling points of 4 substances, W, X, Y and Z.

Substances	Melting Point ($^{\circ}\text{C}$)	Boiling Point ($^{\circ}\text{C}$)
W	35	78
X	52	87
Y	49	91
Z	24	69

At which one of the following temperatures, would **only two** of the substances be in liquid state?

- (1) 10°C
- (2) 68°C
- (3) 60°C
- (4) 90°C

13. Which of the following statements about light and shadow are false?

- A A source of heat is also a source of light.
- B Light enables us to identify the shapes of objects.
- C The weaker the light source, the darker the shadow formed.
- D Two light sources shining on an object will always cast two shadows.

(1) A and B only

(2) B and D only

(3) A, C and D only

(4) B, C and D only

14. Study the classification chart below carefully.

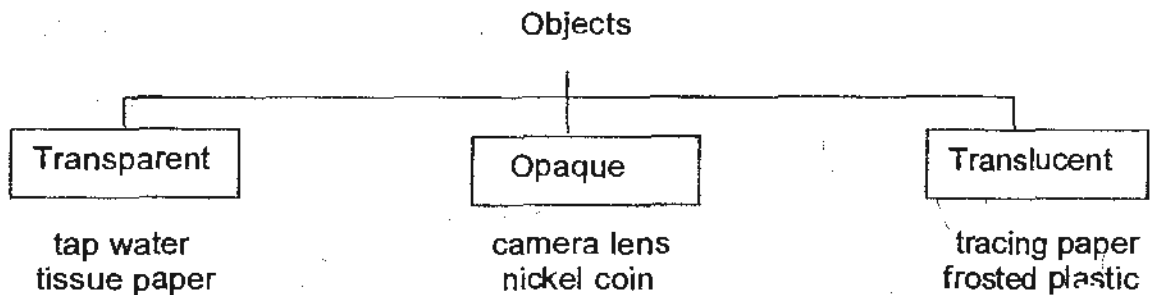

Which of the above objects are wrongly classified?

- (1) tap water and tissue paper
- (2) tracing paper and nickel coin
- (3) tissue paper and camera lens
- (4) nickel coin and frosted plastic

15. Steven hung a word written on a cardboard in front of a mirror. The reflected image of the word is seen in the mirror as shown below.

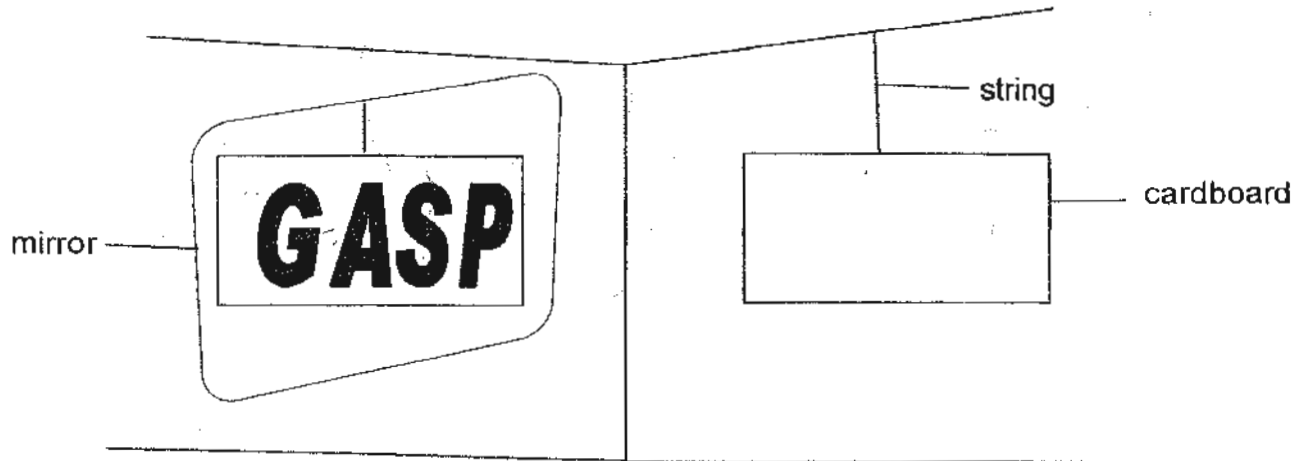

Which one of the following below shows the word as printed on the cardboard?

(1) **PSAG**

(2) **QV2P**

(3) **QV2P**

(4) **PSAG**

16. The diagram below shows three similar cylindrical sticks, A, B and C, placed at different distances in front of a screen. An even light source was switched on and the shadows of A, B and C were cast on the screen.

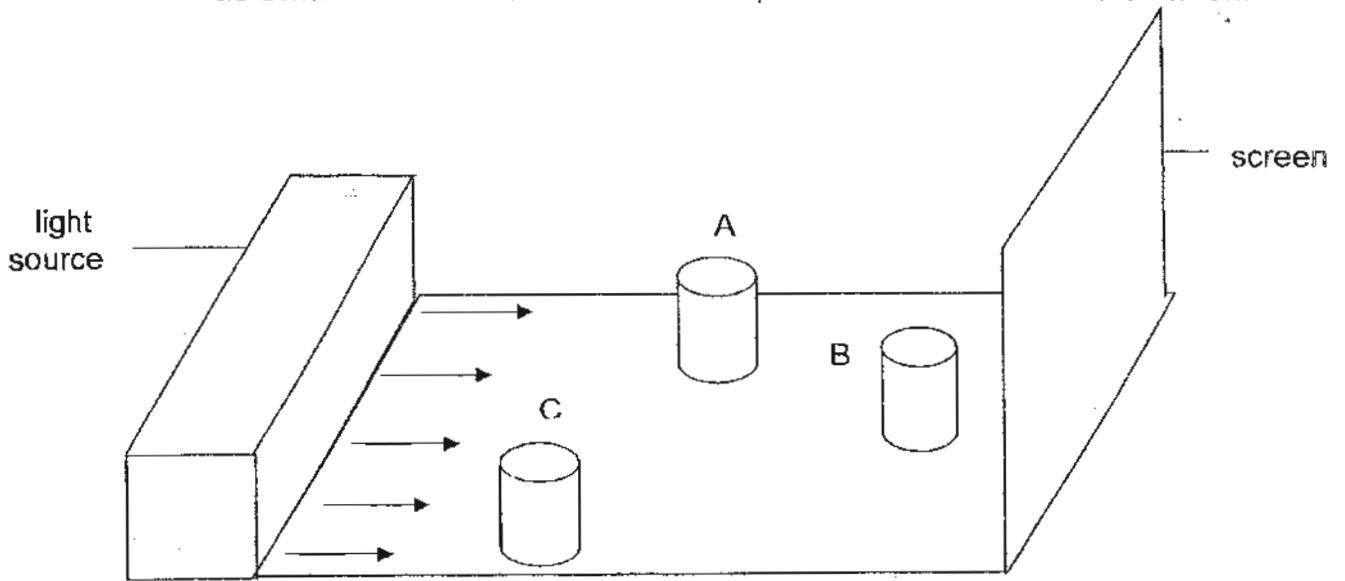

Which one of the following diagrams correctly shows the shadows of the sticks A, B and C, on the screen?

(1)

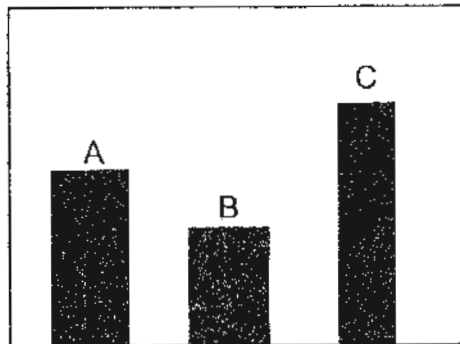

(2)

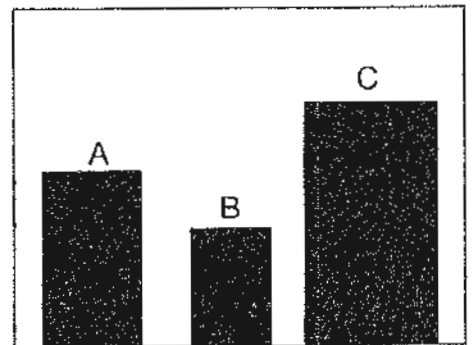

(3)

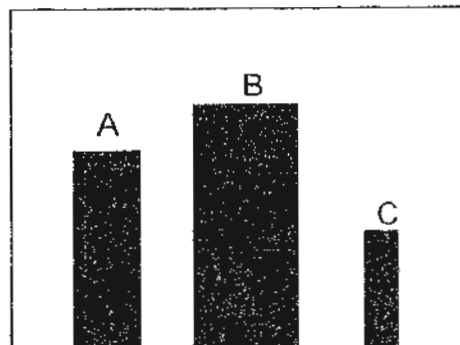

(4)

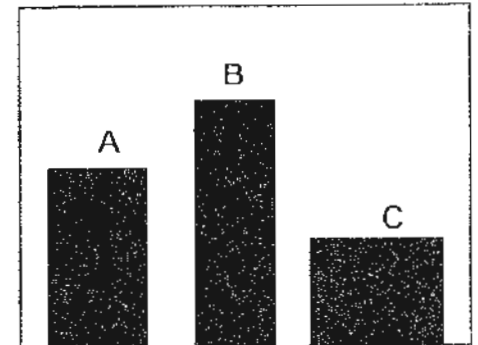

17. Lalit set up the experiment in a dark room as shown below.

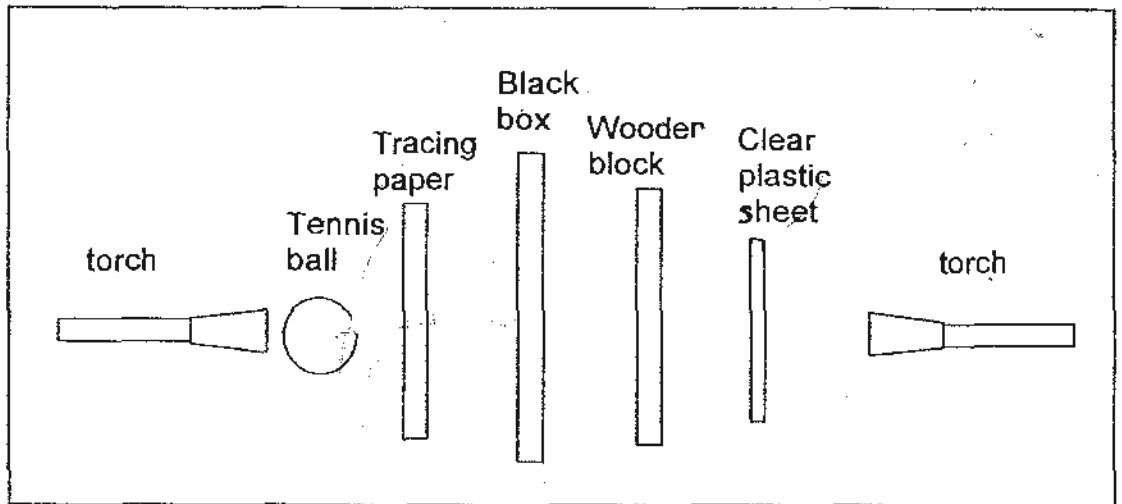

After Lalit switched on both the torches, he recorded his observations. He put a tick in the table for the object that had a shadow cast on it. Which one of the following observations is correct?

	Tennis ball	Tracing Paper	Black box	Wooden block	Clear plastic sheet
(1)		✓			
(2)		✓	✓	✓	
(3)		✓	✓	✓	✓
(4)	✓	✓	✓	✓	

18. Andy shone his torch at the following ceramic container. There was a star printed on one side of the container.

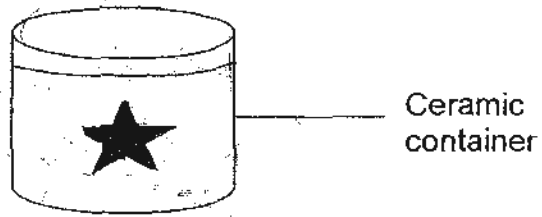

Which one of the following shadows will not be possible?



20. Danny observed the shadow cast by a lamp post under the sun. Which one of the following graphs shows the length of the shadow cast from 1 p.m. to 5 p.m.?

(1)

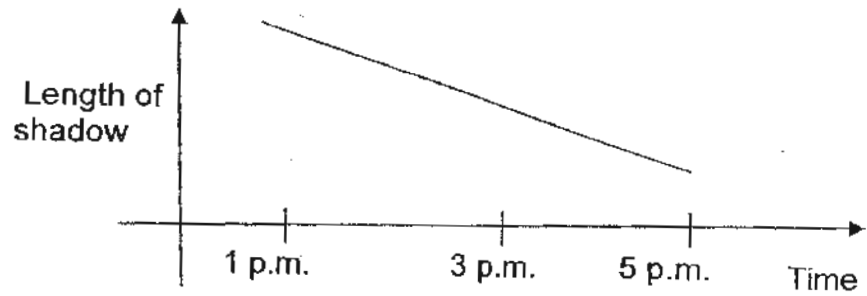

(2)

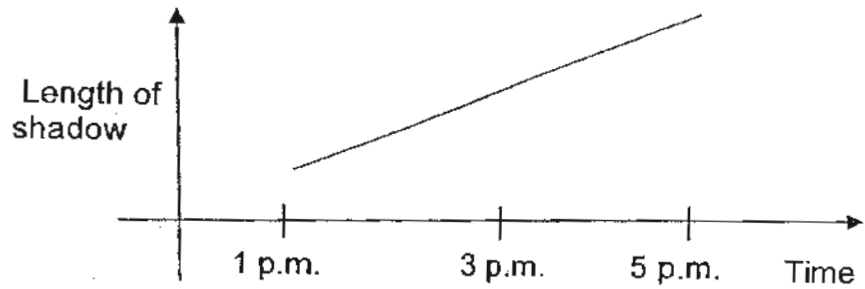

(3)

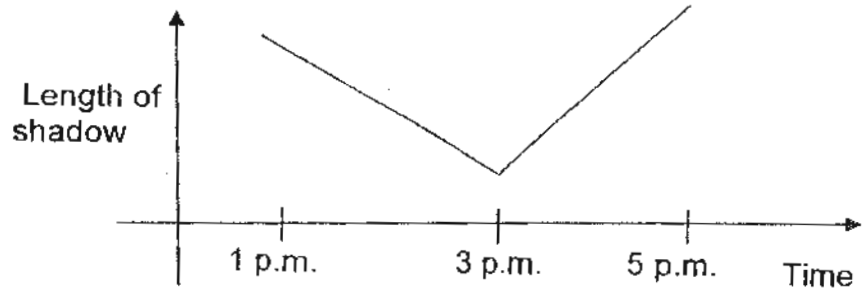

(4)

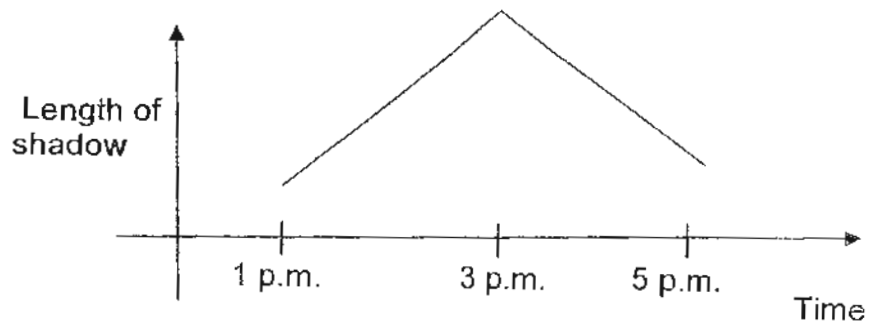

21. Aunt Mary is looking for a one room flat. There are 4 flats for her viewing. They are similar except for the room arrangement. She likes the morning's warm sun rays to wake her up but she does not like her living room to be heated by the evening sun. Which one of the following flats will suit her requirements best?

(1)

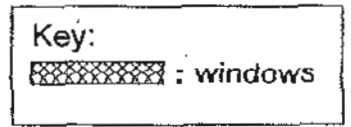
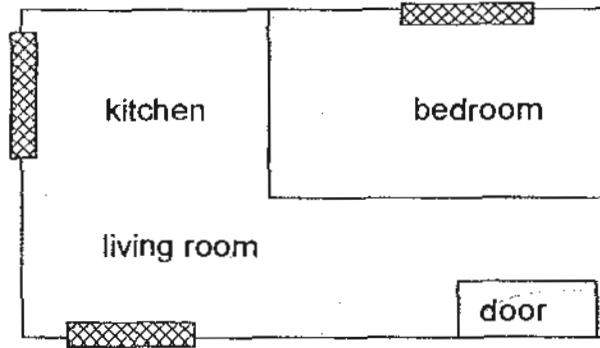

(2)

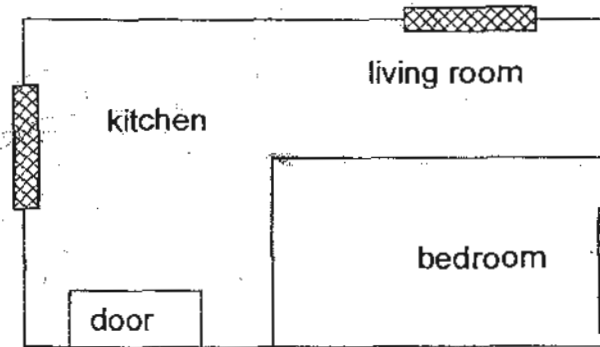

(3)

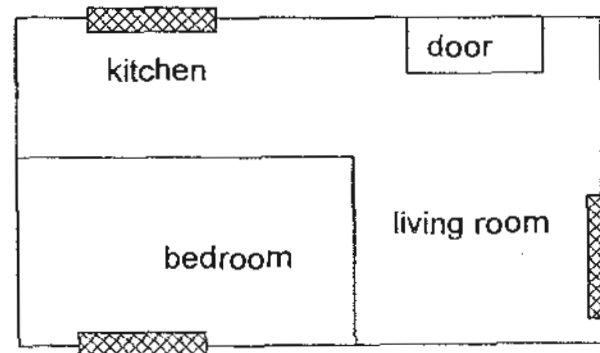

(4)

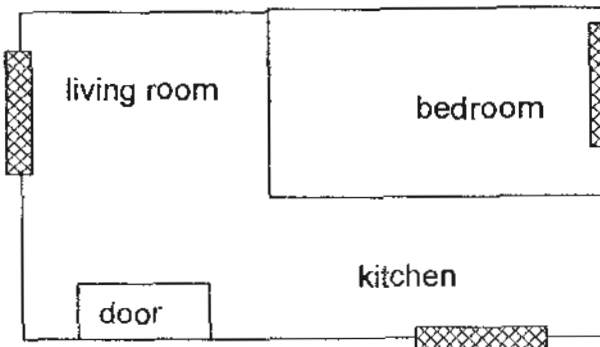

22. Study the flow chart below.

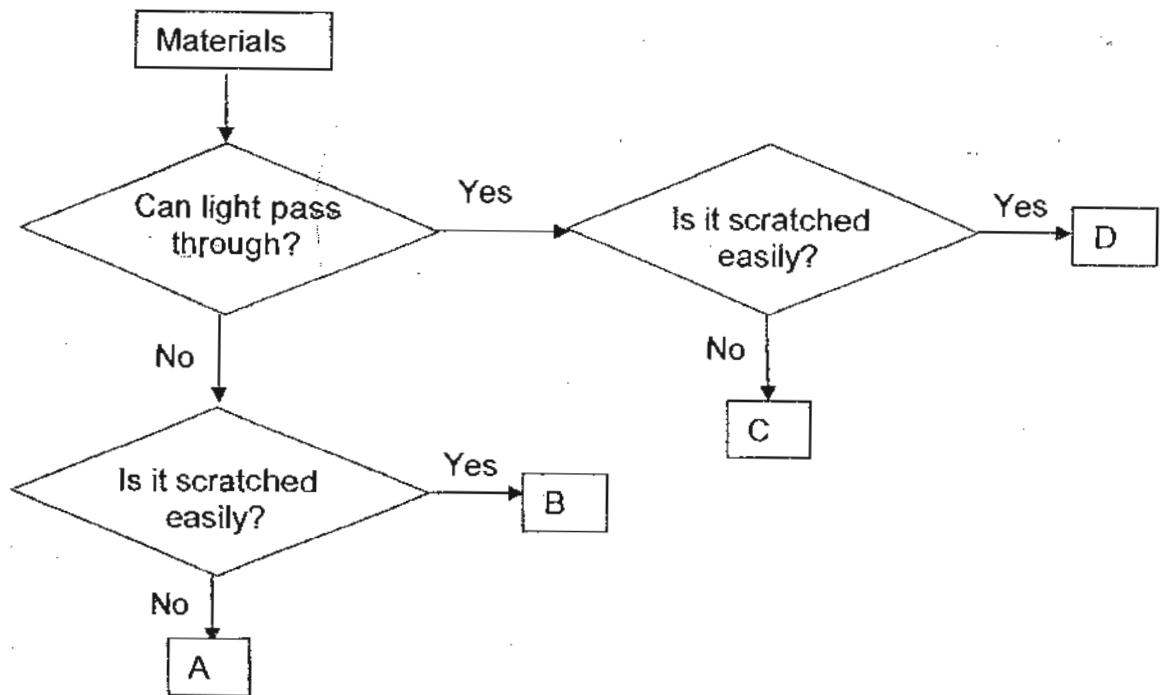

Which material will be most suitable to make the lens of a pair of sunglasses?

(1) A only

(2) B only

(3) C only

(4) D only

23. Khairil conducted an experiment to find out how the colour of a material affects the amount of heat absorbed by the cloth. He placed two similar blocks of ice in the basketball court and covered them with cloths of different colours. Cloth A is pink while cloth B is dark red.

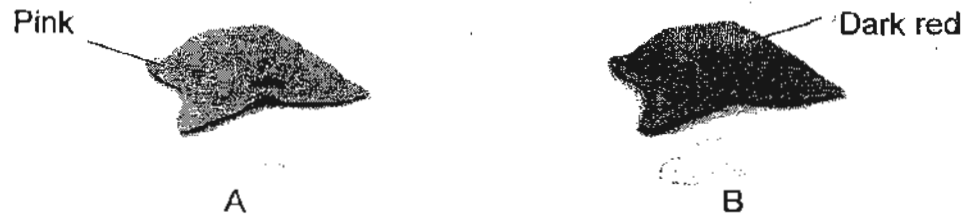

Which one of the following statements is a likely hypothesis for his experiment?

- (1) The block of ice covered by cloth B will melt first.
 - (2) The block of ice will melt because of heat from the sun.
 - (3) Both blocks of ice will absorb heat from the surroundings.
 - (4) Cloth B will release more coldness to the surroundings.
24. Polly wanted to find out if the temperature of the water affects how fast heat is transferred. She mixed the water in Beakers 1 and 2 in each set-up together and recorded the final temperature. She repeated the experiment with different set-ups.

The table below shows the volume and temperature of water in Beakers 1 and 2 for each set-up before mixing.

Set-up	Volume of water before mixing (cm ³)		Temperature of water before mixing (°C)	
	Beaker 1	Beaker 2	Beaker 1	Beaker 2
A	100	100	50	25
B	100	100	100	25
C	50	50	100	25
D	50	50	25	100

Which two set-ups should she use to arrive at a conclusion for her experiment?

- (1) A and B
- (2) A and D
- (3) B and C
- (4) C and D

25. The set-up below shows an experiment conducted by Ms Ong in the science laboratory.

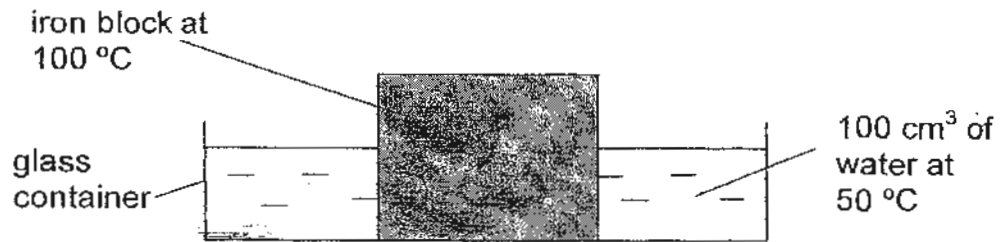

Which one of the following statements accurately describes the transfer of heat in the above experiment?

- (1) The water would begin to boil.
- (2) Heat from the iron block is transferred only to the water.
- (3) The change in temperature of the iron block gets slower over time.
- (4) The temperature of the iron block after five hours is between 50 °C and 100 °C.

26. Joan compared three blocks of ice, A, B and C, at 0°C as shown below.

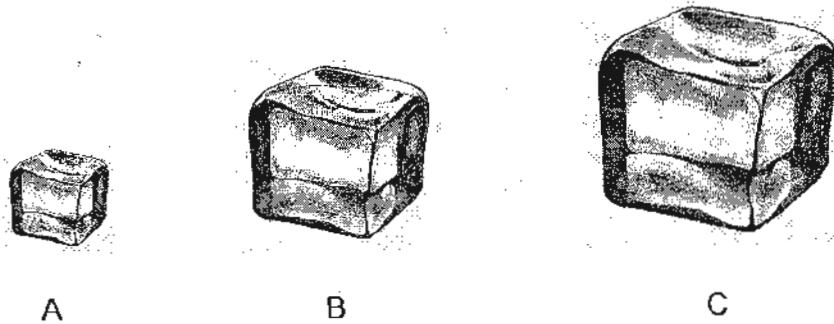

Which one of the following statements is true about the blocks of ice?

- (1) Ice cube A has the least amount of heat.
- (2) Ice cube C has the least amount of heat.
- (3) All the ice cubes have no heat because their temperatures are at 0 °C.
- (4) All the cubes have the same amount of heat because they are at the same temperature.

27. Two metal bars, M and N, of different temperatures are placed in contact with each other. Their temperatures are recorded and presented in the graph below.

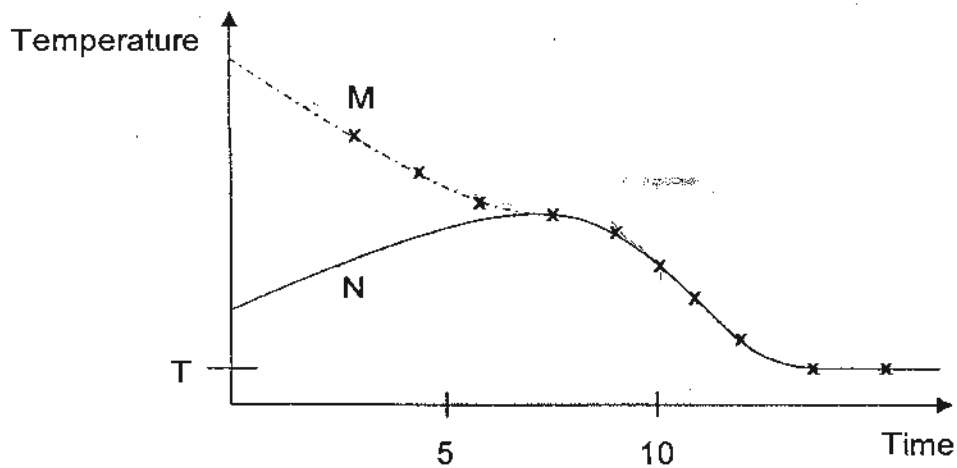

Which of the following statements accurately describe the transfer of heat and/or change in temperature during the experiment?

- A Metal M lost heat to metal N.
- B Both metal bars had the same temperature after 10 minutes.
- C Both metal bars reached temperature T, which is room temperature.
- D As both metals reached the same final temperature, both metals lost the same amount of heat.

- | | | | |
|-----|-----------------|-----|--------------------|
| (1) | A, B and C only | (2) | A, B and D only |
| (3) | B, C and D only | (4) | A, B, C and D only |

28. Which one of the following statements about heat is correct?

- ~~(1)~~ Heat travels in a straight line.
- ~~(2)~~ A thermometer is used to measure the amount of heat of an object.
- ~~(3)~~ When one object is placed on top of another, the object on top will gain heat because heat rises.
- (4) At the same temperature, a dark coloured object will give out more heat than a light coloured object.

a light



南洋小學

NANYANG PRIMARY SCHOOL

PRIMARY FOUR SCIENCE

SEMESTRAL ASSESSMENT 2

2010

BOOKLET B

Date : 29th October 2010

Duration : 1 h 45 min

Name : _____ ()

Class: Primary _____ ()

Marks Scored:

Booklet A:		60
Booklet B :		40
Total :		100

Parent's signature:

DO NOT OPEN THIS BOOKLET UNTIL YOU ARE TOLD TO DO SO.
FOLLOW ALL INSTRUCTIONS CAREFULLY.

Booklet B consists of 13 printed pages including this cover page.

Section B (40 marks)

Write your answers to questions 31 to 46 in the spaces provided.
Marks will be deducted for misspelt key words.

31. The diagram shows a plant.

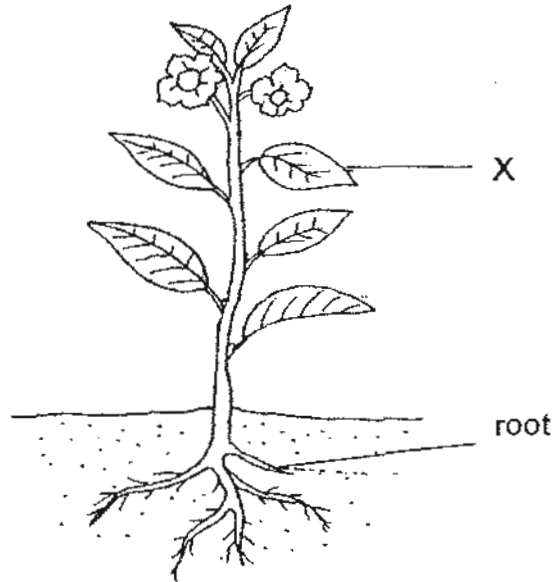

(a) Label plant part X. [1]

X: _____

(b) One substance that roots of a plant take in from the soil is [1]

32. Choose the correct words from the box to answer the questions below.

gullet large intestine mouth small intestine stomach

(a) In a human digestive system, name ~~there~~ part where
digestion first takes place : _____ [1]

(b) digestion is completed : _____ [1]

33. Ahmad sees **only** a candle flame at the corner when he enters a completely dark room.

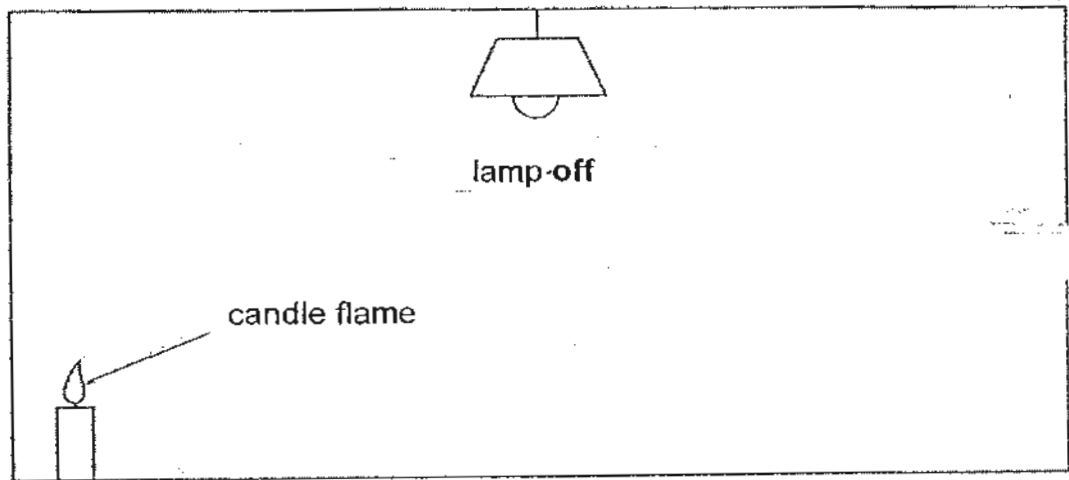

- (a) Ahmad can see the candle flame because it _____ light. [1]

When he switches on the light in the room, he sees both the candle flame and object B.

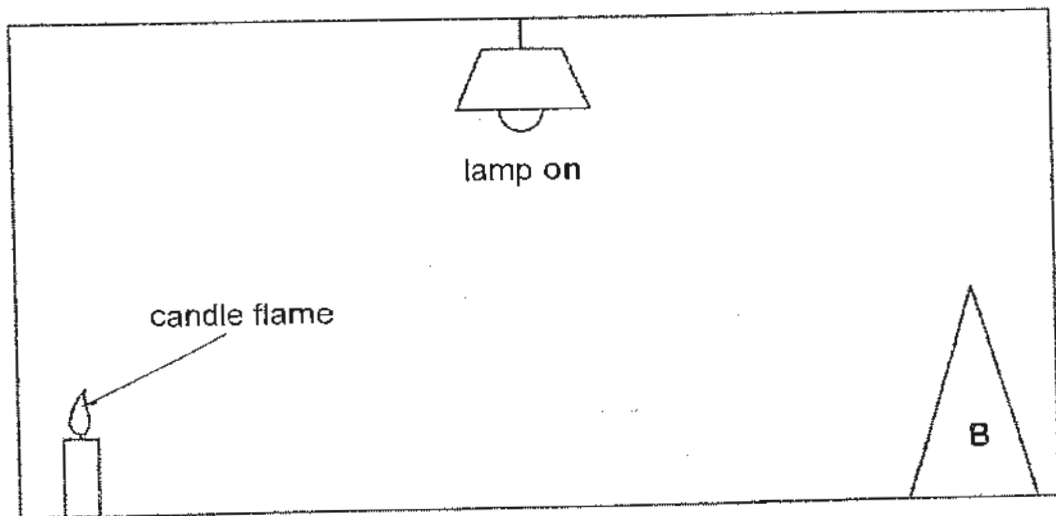

- (b) Ahmad can see object B because it _____ light from the lamp. [1]

34. Susan places a magnet near an iron rod. The iron rod moves towards the magnet.



- (a) The magnet exerts a _____ on the iron rod. [1]
- (b) Choose the correct word from the box to answer the question below. [1]

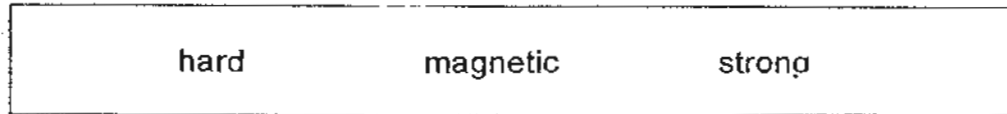

Susan's observation shows that iron is a _____ material.

35. Carol used an instrument to measure the temperature of water in a glass.

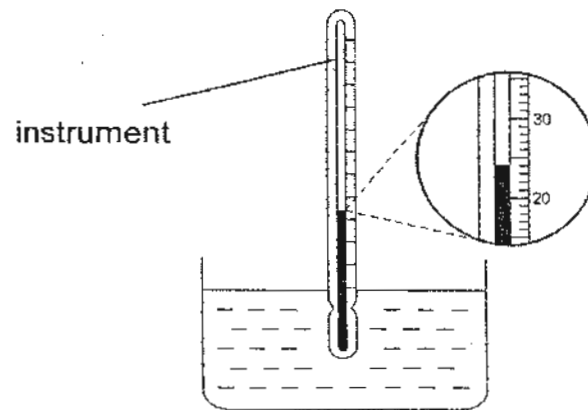

- (a) What is the instrument called? [1]
- _____
- (b) What is the temperature of the water in the glass? [1]
- _____ °C.

36. Mr Chandra wanted to demonstrate the effects of heating and cooling to his class. He used all the following apparatus.

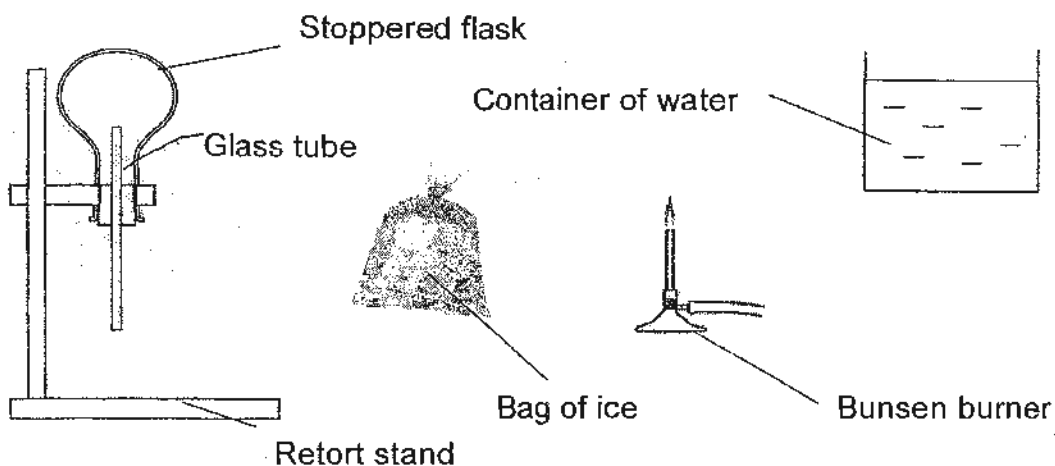

The diagrams below show what the set-up looked like at the beginning and at the end of the demonstration.

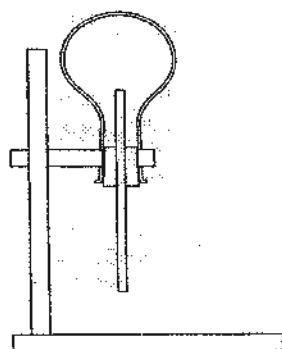

Step 1

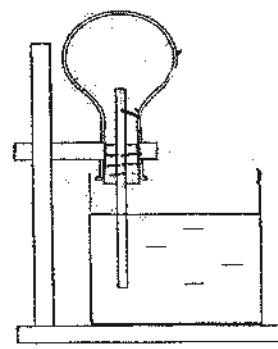

End of experiment

The table below shows the steps taken by Mr Chandra during the demonstration. Fill in the missing steps. [2]

Step 1	Heat the flask with the bunsen flame for 3 minutes
Step 2	Remove the flame from the flask
Step 3	
Step 4	

37. George conducted a fair experiment to determine which metal, A, B or C would expand the most when heated. He heated two different bimetallic strips and his results are shown below.

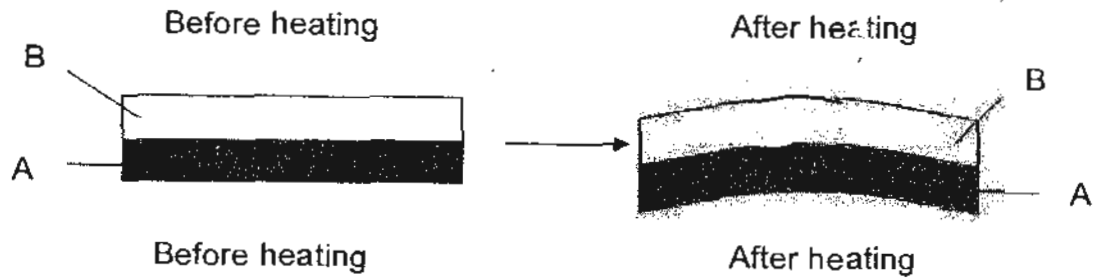

He then heated the following strip of metal.

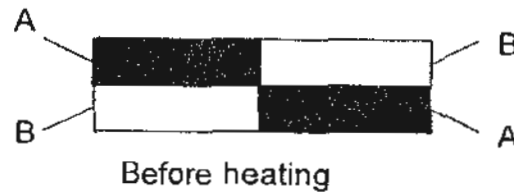

- (a) In the space provided below, predict and draw the results that he is likely to obtain when he heats the strip of metal. Label your diagram clearly. [2]

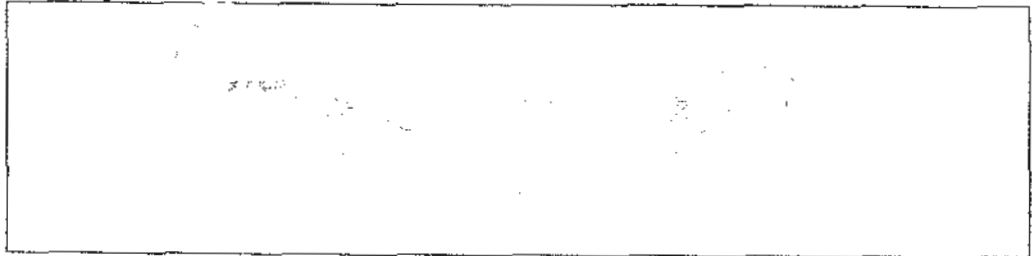

Another metal bar was then heated.



- (b) Fill in the boxes below with the letters, A, B and C based on the ability of the metals to expand as shown above. [1]

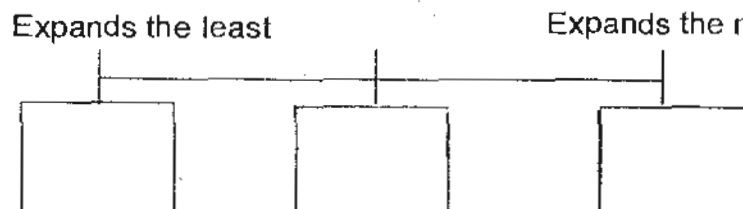

38. Min collected 4 water samples from 4 different ponds, P, Q, R and S. He placed 50ml of water sample P into a small glass beaker and set up the experiment as shown below.

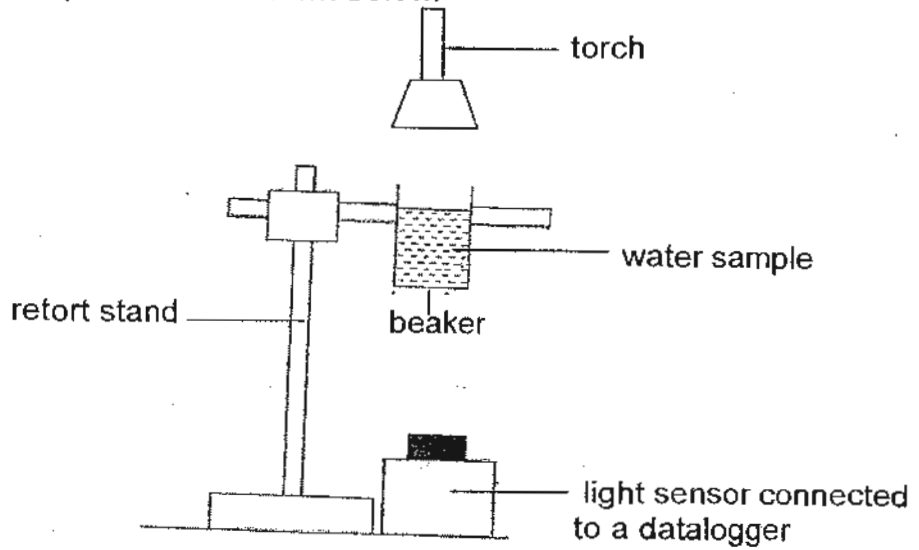

Min lit his torch and shone it over water sample P in the beaker. He used a datalogger to measure how much light was able to pass through the water sample P in the beaker. He recorded three sets of readings for water sample P.

Min repeated the same experiment for the other 3 water samples, one at a time. He recorded his observations in the table below.

Number of readings	Reading on the light sensor for each water sample (Lux)			
	Pond P	Pond Q	Pond R	Pond S
1 st	500	800	60	1105
2 nd	480	805	64	1100
3 rd	495	810	58	1007

- (a) In which sample, P, Q, R or S, will a fully-submerged water plant grow best? Explain why. [2]

- (b) Explain why Min needed to obtain 3 readings for each water sample. [1]

39. Study the diagram below. Mr Lee took 3 identical sticks and placed each one of them at positions X, Y and Z in front of a lamp post.

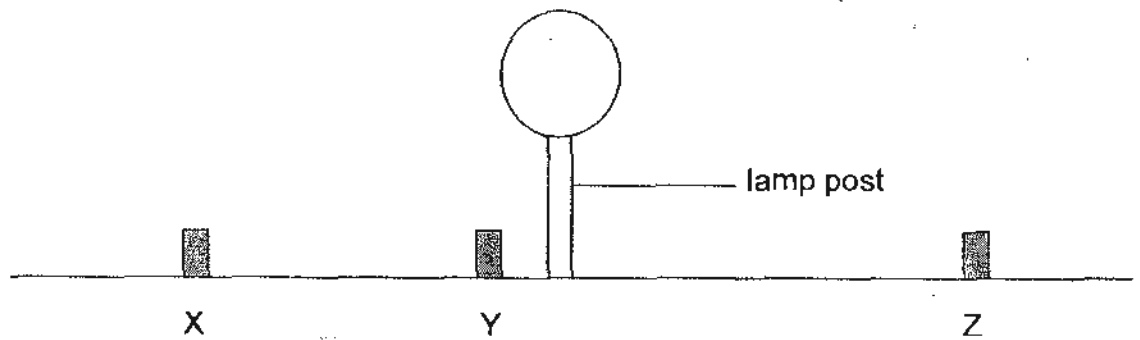

He drew up a bar graph to show the length of each shadow.

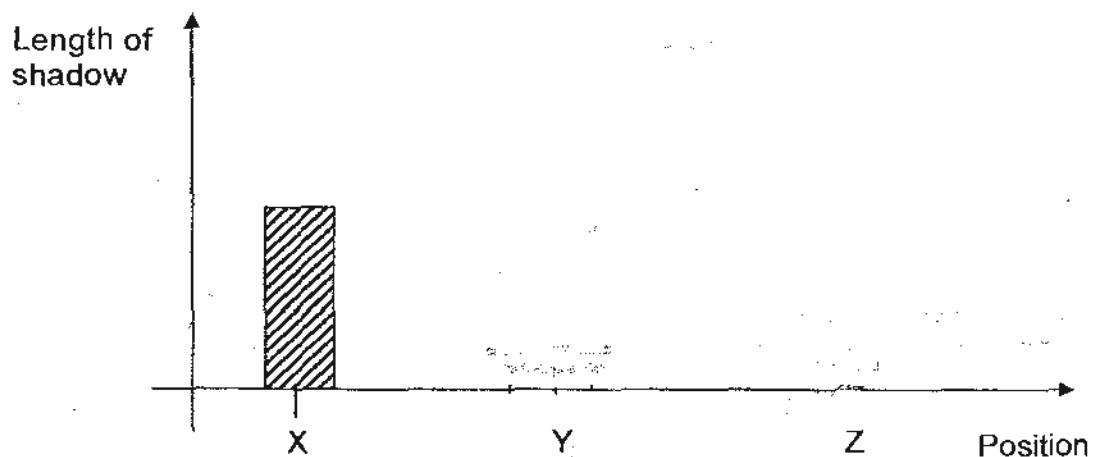

The length of the shadow of the stick at position X has been completed in the bar graph for you.

- (a) On the graph above, complete the graph to show the lengths of the shadows formed by sticks Y and Z. [2]
- (b) State what would happen to the shadow of X if the lamp becomes dimmer. [1]

- (c) State two properties of light that explain how a shadow is formed. [1]

40. Study the experiment below carefully.

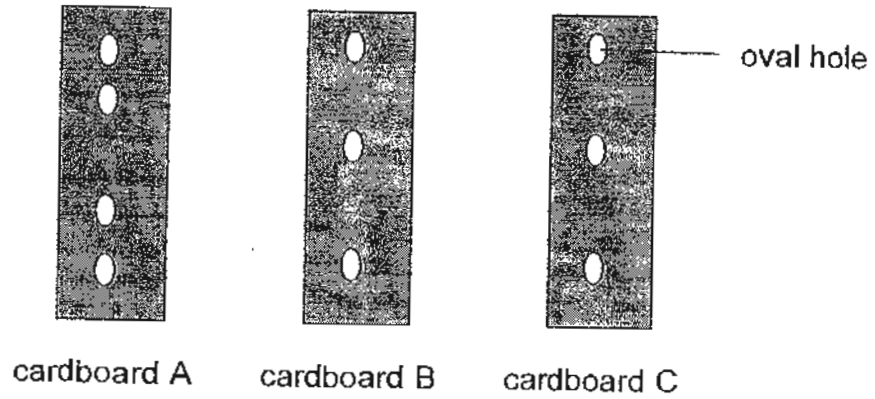

Front view of cardboards

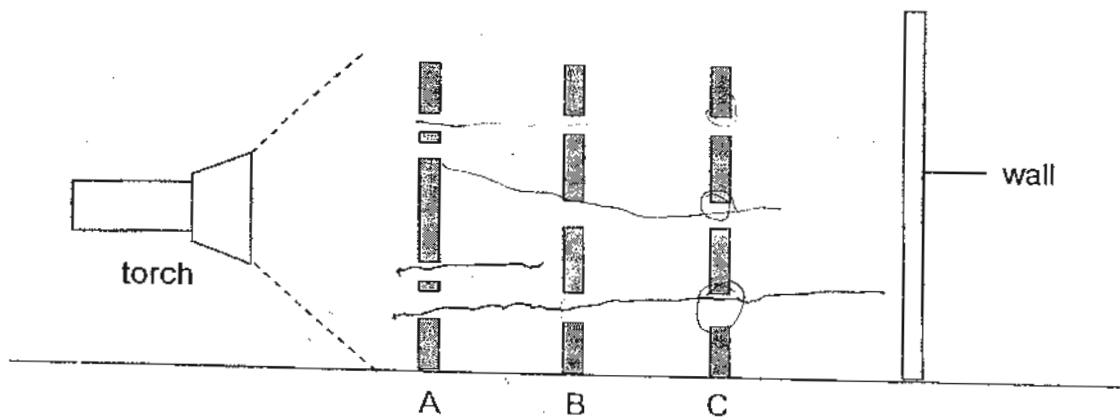

Set up of experiment

The 3 cardboards, A, B and C were placed in a straight line between the wall and the torch as shown above.

- (a) When the torch is turned on, how many oval spots of light will be seen on the wall? [1]

- (b) What is the aim of the experiment above? [1]

The same experiment was conducted using different cardboards, D and E, as shown below.

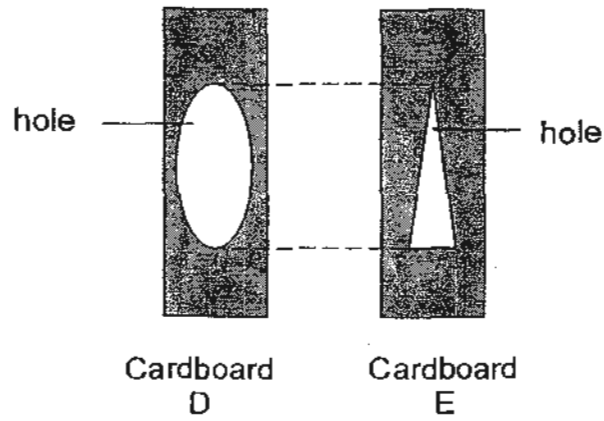

Front view of cardboards

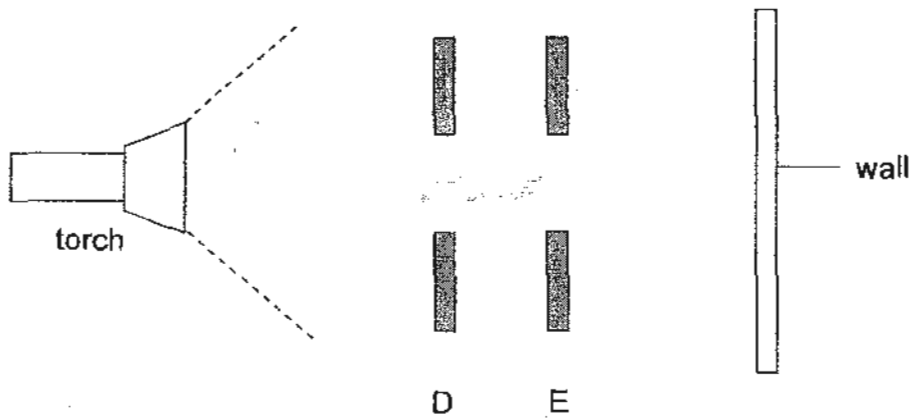

Set up of experiment

(c) What is the shape of the shadow formed on the wall? [1]

(d) State one way to make the shadow on the wall bigger. [1]

41. Simone set up an experiment as shown below. She used beakers of different materials for her experiment.

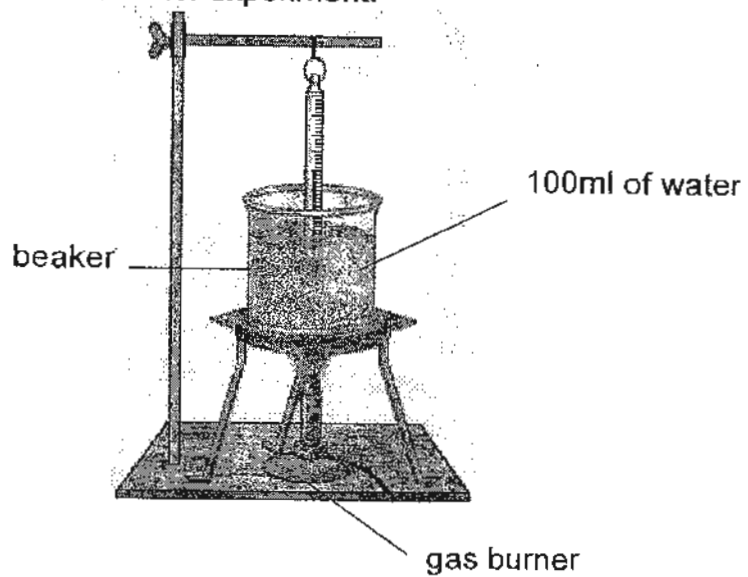

She recorded the results of her findings as shown below:

Material of beaker	Time taken for water to boil (min)
Glass	5
Ceramic	8
Metal	3

- (a) What was the aim of her experiment? [1]

- (b) Based on the experimental results that Simone obtained, which material should she use to make a container to keep drinks cold? Explain your answer. [2]

- (c) What would Simone observe if she used two gas burners? [1]

42. Ikmal conducted an experiment in the science laboratory. He covered similar ice cubes with different materials and recorded the time it took for the ice cube to melt completely. His results are shown in the table below.

Experiment	Mass of ice cube (g)	Material used (10g)	Time taken to melt completely (s)
A	10	Nothing	280
B	10	Straw	500
C	10	Iron Filings	180
D	10	Sawdust	640

Ice is sometimes packed in a mixture of straw and sawdust. A common way of packing is shown below.

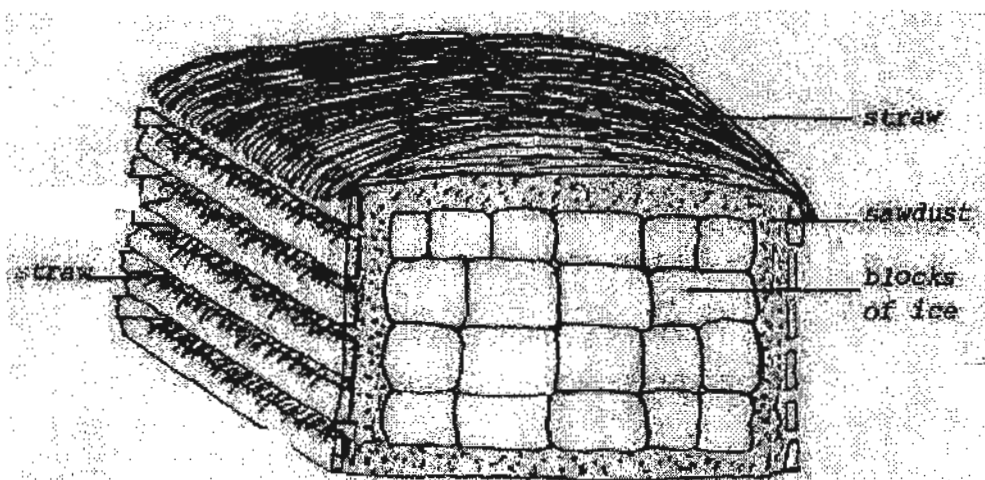

- (a) Explain how straw and sawdust help keep ice frozen. [2]

- (b) Suggest, with reasons, what would happen if the sawdust was replaced with iron filings. [2]

43. Faith conducted a fair experiment as shown below. Both thermometers are placed at equal distances from the container of boiling water.

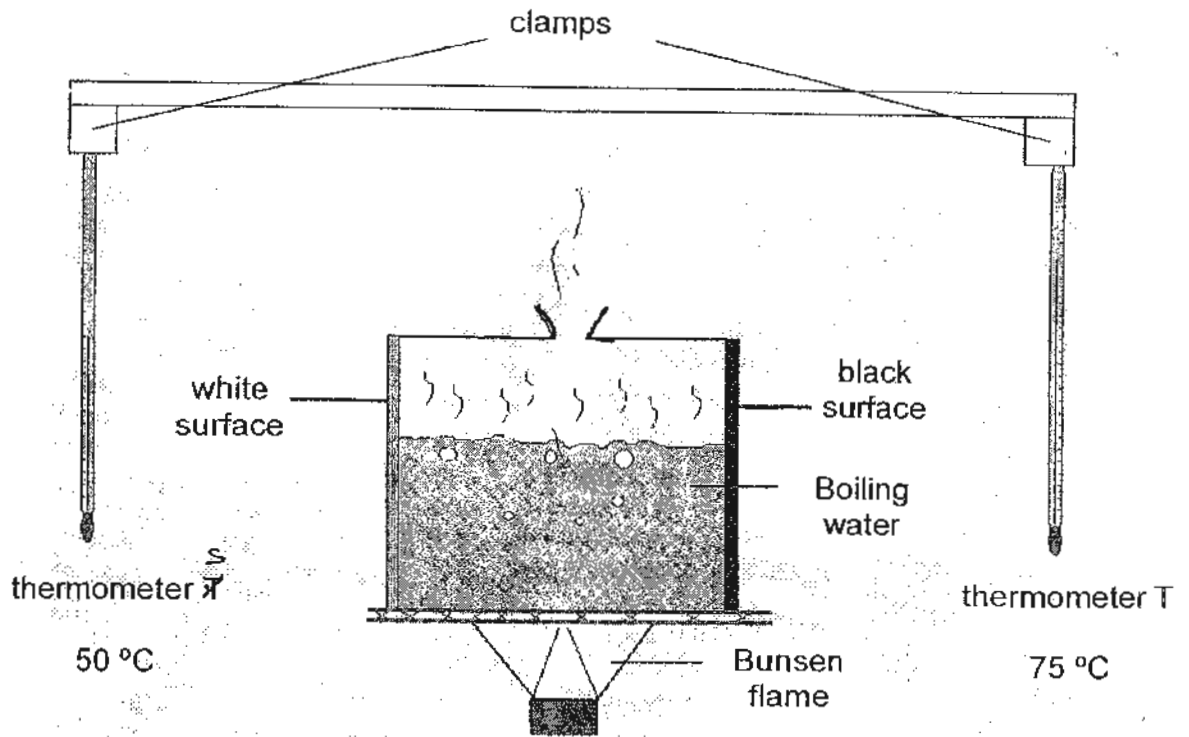

(a) What was the aim of her experiment? [1]

(b) Based on the information above, write down Faith's conclusion. [1]

Faith then placed the thermometers into the water. Thermometer S is placed close to the white, shiny surface and thermometer T was placed close to the black, dull surface.

(c) Predict the temperature readings of both thermometer S and thermometer T. Explain your answer. [2]

44. The diagram below shows a system in the human body.

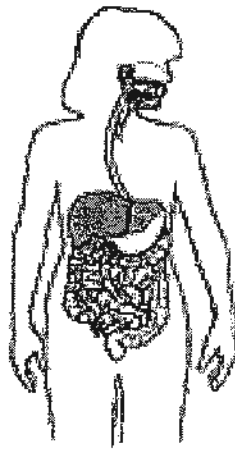

- (a) State the organ(s) of this system where substances are passed into the blood. [1]

- (b) Besides absorption, this system performs another major process, process L. State the **organ** where process L begins. [1]

Setters:

Ms Alice Chong
Mr Chan Melzone

-----END OF PAPER-----

ANSWER SHEET

EXAM PAPER 2010

SCHOOL : NANYANG PRIMARY SCHOOL
SUBJECT : PRIMARY 4 SCIENCE

TERM : SA2

Q1	Q2	Q3	Q4	Q5	Q6	Q7	Q8	Q9	Q10	Q11	Q12	Q13	Q14	Q15	Q16	Q17
4	1	4	2	1	3	3	3	2	3	3	2	3	3	1	2	4

Q18	Q19	Q20	Q21	Q22	Q23	Q24	Q25	Q26	Q27	Q28	Q29	Q30
4	4	3	2	3	3	1	3	1	1	4	1	2

31 a) Leaf
31 b) Water

32 a) Mouth
32 b) Small Intestine

33 a) Produce
33 b) Reflect

34 a) Magnetic Force
34 b) Magnetic

35 a) It is called a thermometer.
35 b) 24°C

36) Step 3: Place the glass tube into the water.
Step 4: Cool the flask and place the ice onto the flask.

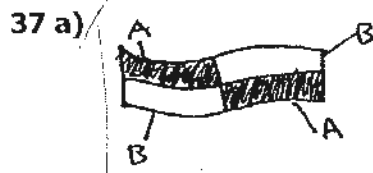

37 b) A, C, B

38 a) S. Most light can pass through for it to photosynthesis/ make food.
38 b) To get reliable readings.

39 a)

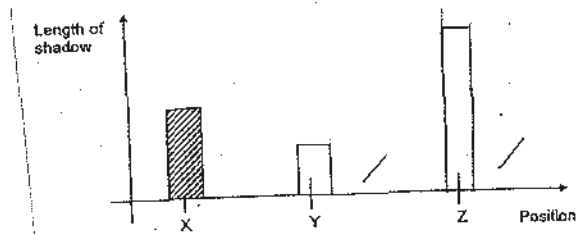

39 b) The shadow will slowly become lighter in colour.

39 c) When light is blocked by an opaque object, a shadow is cast and light travels in a straight line.

40 a) 2

40 b) To find out whether light travels in a straight line.

40 c) It is a rectangle with a triangle-shaped spot of light in it.

40 d) Move the cardboard nearer to the torch.

41 a) To find out which is a poorer conductor of heat than the others.

41 b) She should use a ceramic conductor. The ceramic beaker was the poorest conductor of heat among the three beakers, thus, it can keep the drink cold as heat cannot pass through easily.

41 c) The time taken for the water to boil would be shorter.

42 a) Straw and sawdust are poor conductors of heat. They also trap pockets of air, which is also a poor conductor of heat. This reduces the efficiency of heat transfer and keeps the ice frozen.

42 b) The melting process of the ice will be faster as iron fillings are metal and are a better conductor of heat than sawdust. This allows heat to be more efficiently transferred from the surrounding to the ice, causing it to melt faster.

43 a) She wanted to find out if different colours give out/ emit different amounts of heat.

43 b) Darker colours give off more heat than lighter colours.

43 c) Both thermometers will be at 100°C as they are measuring the temperature of the boiling water.

44) (a) small intestine and large intestine .

(b) mouth or stomach .