

NAME : _____ ()

CLASS: PRIMARY 4 _____

CHIJ ST NICHOLAS GIRLS' SCHOOL



Second Semestral Assessment

2010

Primary 4 SCIENCE

(BOOKLET A)

2 November 2010

Total Time for Booklets A and B: 1 hour 45 minutes

30 questions

60 marks

INSTRUCTIONS TO CANDIDATES

- Do not open this booklet until you are told to do so.
- Follow all instructions carefully.
- Answer all questions.

This paper consists of 18 printed pages.

Section A : (30 x 2 marks)

For each question from 1 to 30, four options are given. One of them is the correct answer. Make your choice (1, 2, 3 or 4). Shade your answer on the Optical Answer Sheet.

1. The flow chart below shows the properties of three different objects, A, B and C.

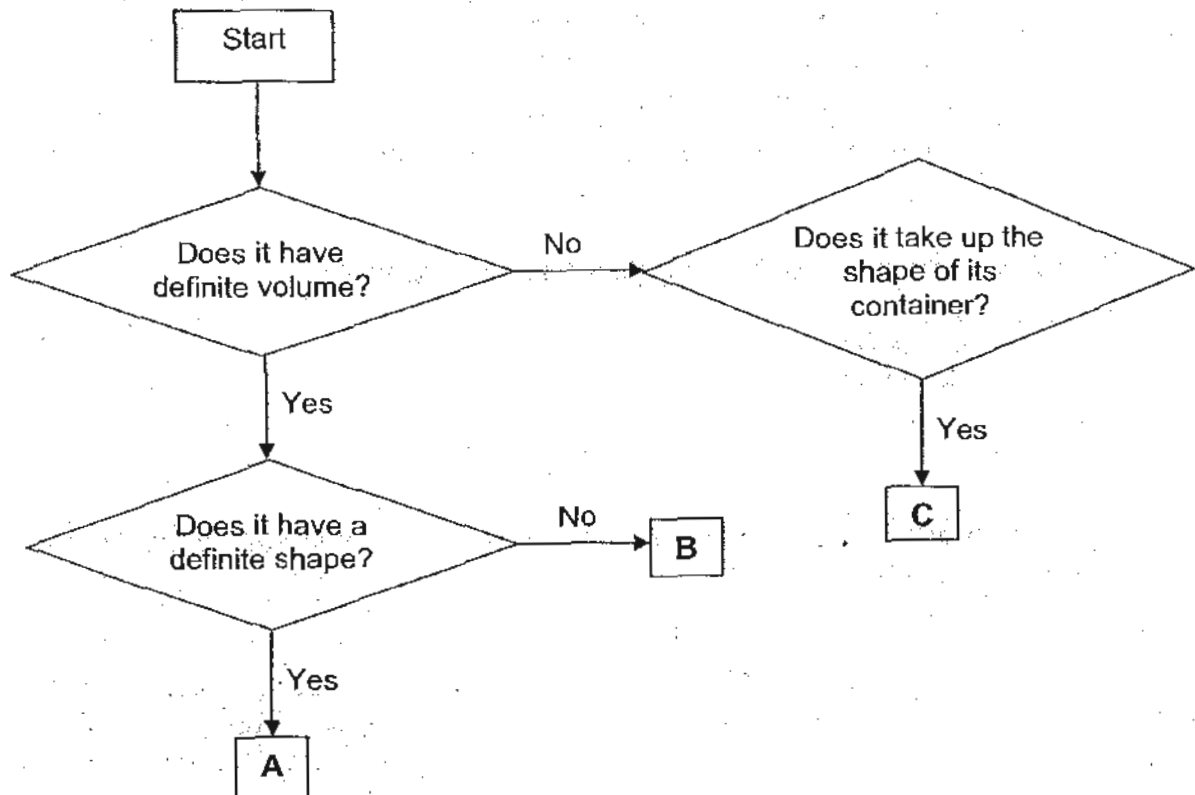

Which one of the following best represents objects A, B and C?

	A	B	C
(1)	Orange juice	Plasticine	Oxygen
(2)	Plasticine	Orange juice	Oxygen
(3)	Plasticine	Oxygen	Orange juice
(4)	Oxygen	Orange juice	Plasticine

2. The diagram below shows a germinating seed.

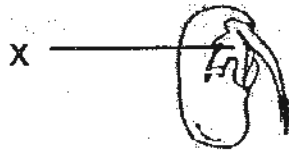

What is the function of the part labelled 'X'?

- (1) It gives the young seedling support.
- (2) It makes food for the young seedling.
- (3) It traps sunlight for the young seedling.
- (4) It provides the young seedling with stored food.

3. The table below shows the characteristics of animal Y.

- It lays eggs.
- It has a beak.
- It has a pair of wings.
- It has feathers on its body.

Which one of the following shows the **correct** order of stages in the life cycle of the animal described above?

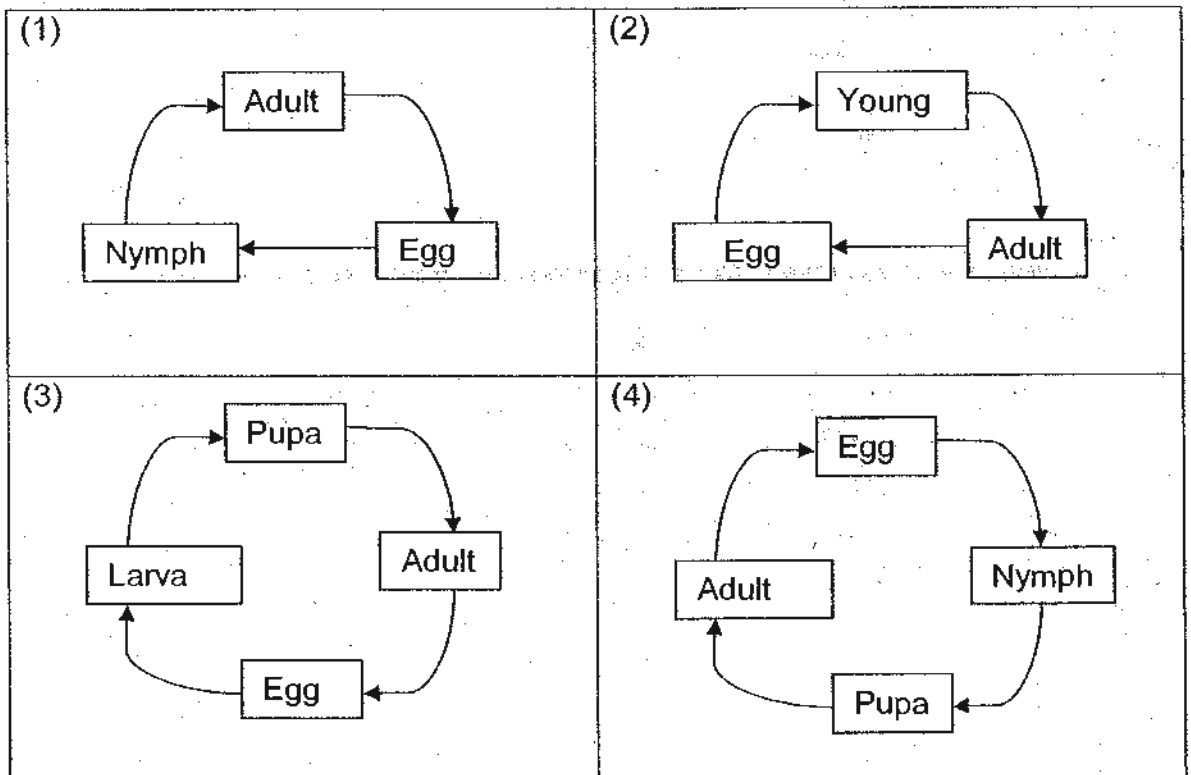

4. Four similar beakers, A, B, C and D, are placed on the same table. Each beaker is filled with water at the temperature as shown below.

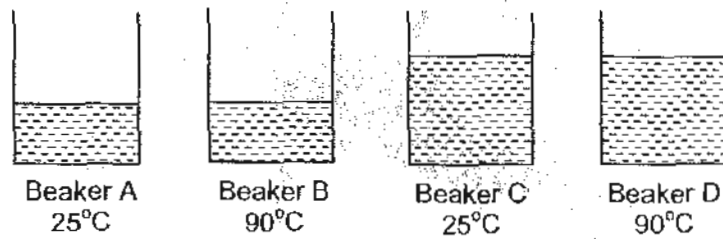

After 5 minutes, which beaker contains water with the most heat?

- (1) Beaker A
 - (2) Beaker B
 - (3) Beaker C
 - (4) Beaker D
5. Which of the following statements show the similarities between the plant transport system and the human transport system?
- A Both systems transport food and water.
 - B Both systems have tubes to transport materials.
 - C Both systems have tubes to transport oxygen and carbon dioxide.
 - D Both systems need an organ to pump the materials in the tubes to different parts.
- (1) A and B only
 - (2) C and D only
 - (3) A, B and C only
 - (4) A, B, and D only

6. The leaves of a mimosa plant closed up when touched.

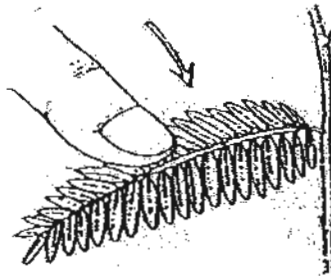

This shows that the mimosa plant is a living thing because it can _____.

- (1) grow
- (2) breathe
- (3) respond
- (4) reproduce

7. Denise can easily scratch a wooden stick with a copper nail.

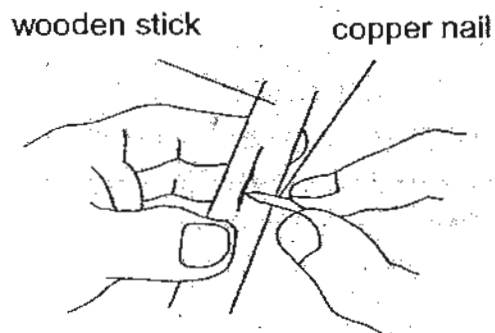

This shows that the copper nail is _____ than the wooden stick.

- (1) harder
- (2) heavier
- (3) stronger
- (4) more flexible

8. The diagram below shows the growth of a young plant with two missing stages P and Q.

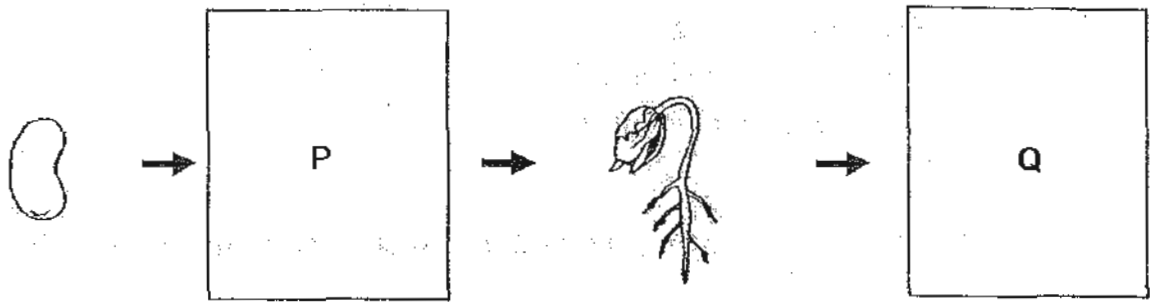

Which one of the following shows the correct stages for P and Q?

	P	Q
(1)		
(2)		
(3)		
(4)		

9. Which one of the following properties is true for both oxygen and balloon?

- (1) Both can be seen.
- (2) Both take up space.
- (3) Both have fixed shapes.
- (4) Both have fixed volumes.

10. Which one of the following shows the correct mass of the apples on the weighing scale below?

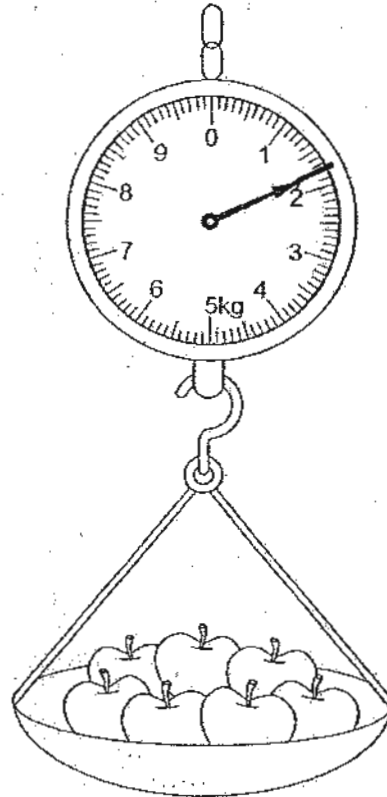

- (1) 1.6 kg
- (2) 1.8 kg
- (3) 2.0 kg
- (4) 2.2 kg

11. The function of the stem of a plant is to _____.

- (1) make food
- (2) take in water
- (3) take in mineral salts
- (4) hold the plant upright

12. What is the main function of the large intestine in the human digestive system?

- (1) It removes digested food from the body.
- (2) It allows water to be passed into the blood.
- (3) It removes undigested food out of the body.
- (4) It slows down the rate of digested food passing into the blood.

13. In which one of the following arrangements will the magnets push each other away?

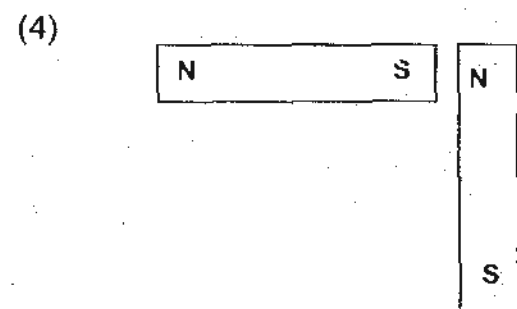
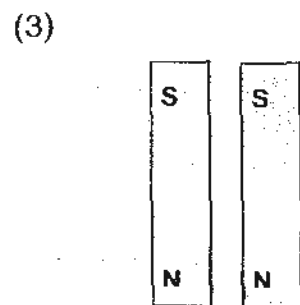
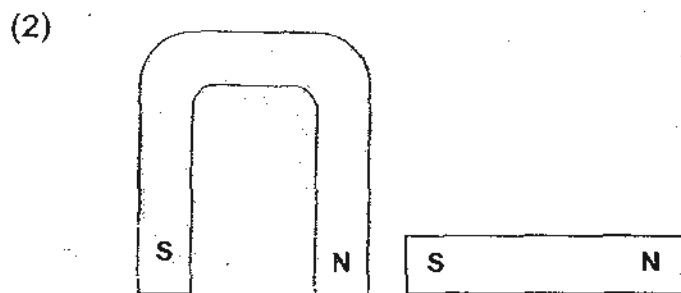
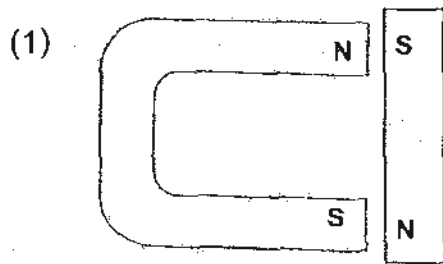

14. Study the picture below.

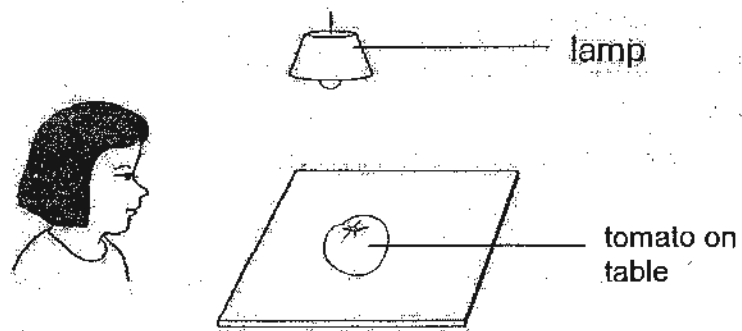

Which one of the following explains why Mary can see the tomato on the table?

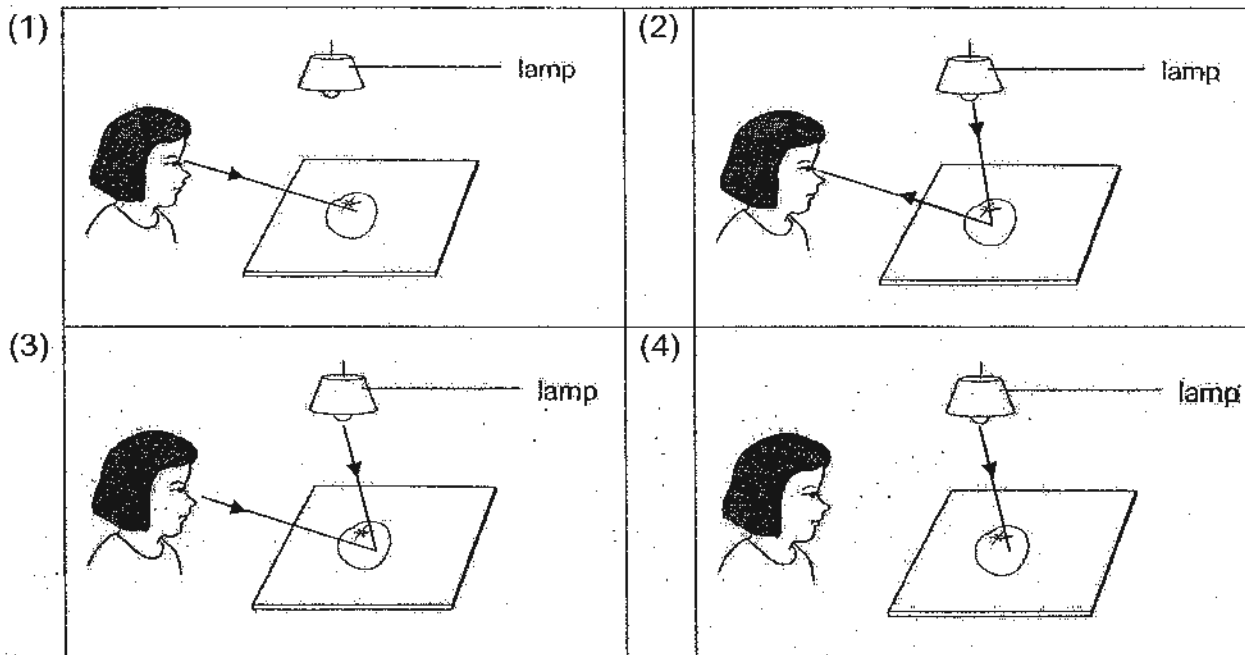
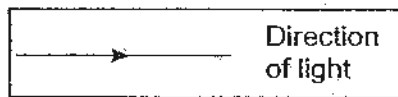

15. James places a metal spoon in a cup of hot water as shown in the diagram below.

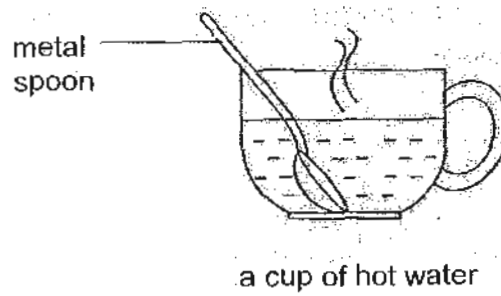

The spoon becomes hotter after a while because _____.

- (1) the cup loses heat to the hot water
 - (2) the spoon loses heat to the hot water
 - (3) the hot water gains heat from the spoon
 - (4) the spoon gains heat from the hot water
16. The diagram below shows 4 containers of different volume.

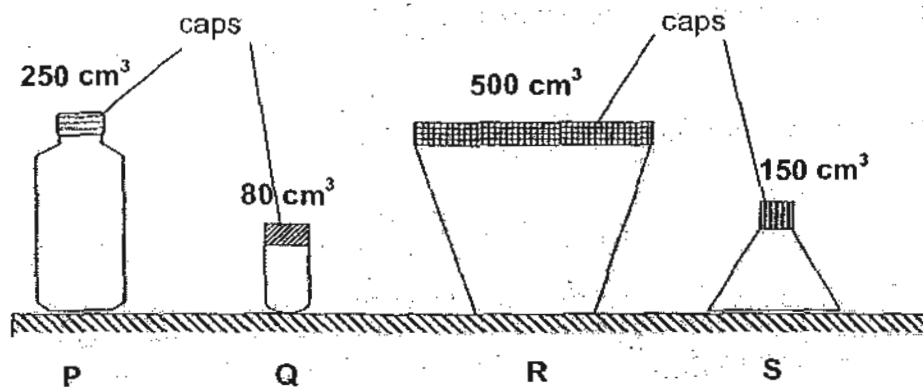

Which of the containers can be totally filled with 100cm³ of air?

- (1) P and R only
- (2) Q and S only
- (3) P, R and S only
- (4) P, Q, R and S

17. Kelvin lowered an empty glass with a small ball into a container of water until it touched the bottom of the container. She observed that the water level inside the glass was not the same as the water level outside. The ball still floated on the water as shown below.

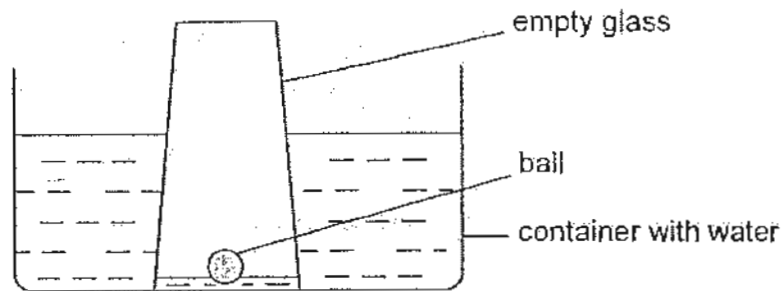

What could be the main reason for the difference in the water level inside and outside the glass?

- (1) The ball in the glass occupied space.
 - (2) The air trapped in the glass occupied space.
 - (3) The ball pushed the water out from the glass.
 - (4) The air trapped in the glass dissolved in the water.
18. Study the classification chart below.

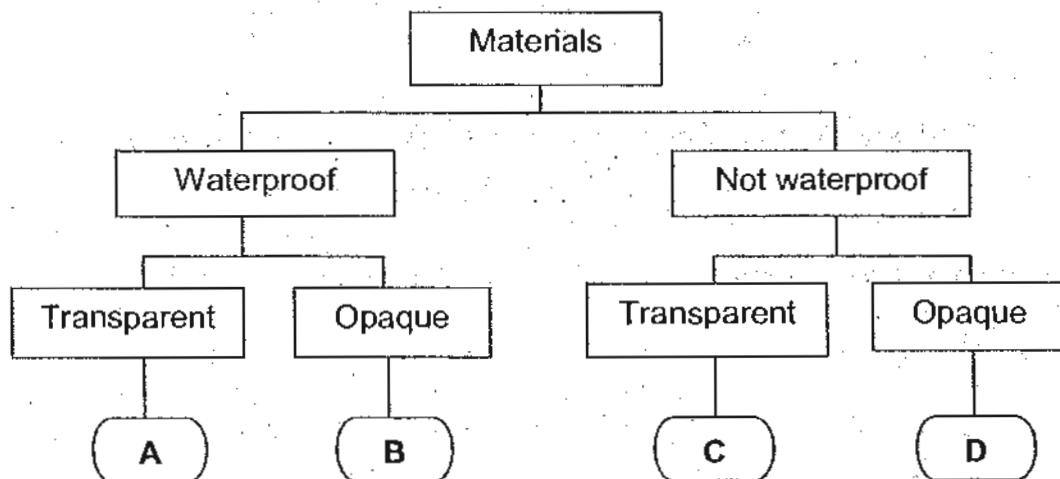

Which of the following could object **A** and **D** possibly be?

	A	D
(1)	Newspaper	Raincoat
(2)	Glass	Cardboard
(3)	Blanket	Newspaper
(4)	Frosted glass	Cellophane

19. When a dented ping pong ball is placed in a beaker of hot water as shown in the diagram below, it becomes round again.

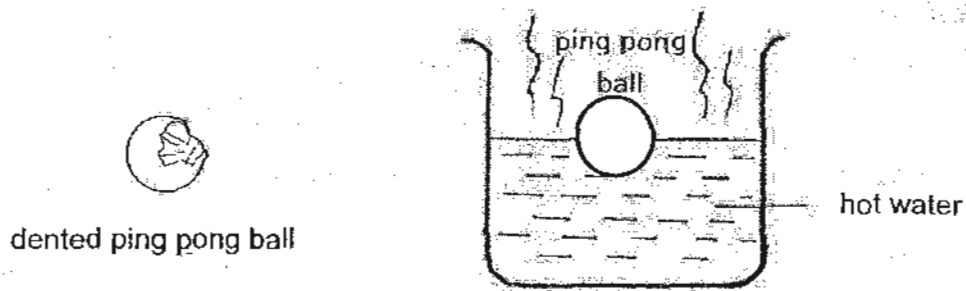

Which one of the following explanations is correct?

- (1) The ball expands.
 - (2) Hot air enters the ball.
 - (3) The ball increases in mass.
 - (4) Air in the ball increases in volume.
20. Alan works at the Mass Rapid Transit (MRT) station. At the station, he checks the gaps along the train track as shown below.

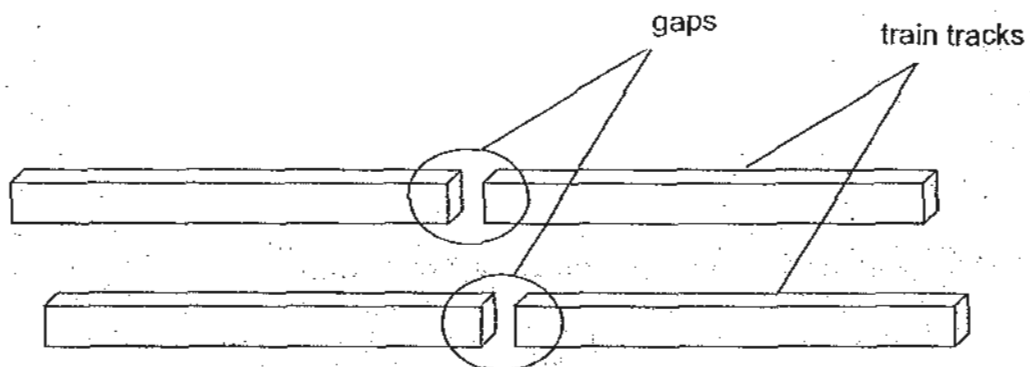

The gaps on the train track allow _____.

- (1) the expansion of the track on hot day
- (2) the contraction of the track on cold day
- (3) the expansion of the track on a cold day
- (4) the contraction of the track on a hot day

21. Object Q is brought near a bar magnet and its end marked Z is attracted to the N-pole of the magnet as shown below.

Before

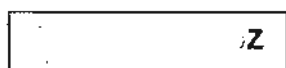

Object Q



Bar magnet

After

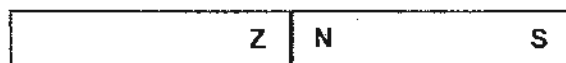

Object Q

Bar magnet

Based on the observation above, object Q could be a _____.

- A nickel rod
 - B copper rod
 - C magnet
- (1) A only
(2) C only
(3) A and C only
(4) A, B and C

22. The diagram below shows a U-shaped magnet.

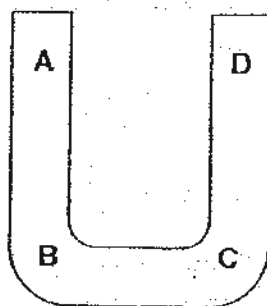

Bala placed the entire U-shaped magnet into a box of iron pins. When he lifted the magnet out of the box, at which points will he see the most number of pins attracted to the magnet?

- (1) A and B only
- (2) A and D only
- (3) B and C only
- (4) C and D only

23. Five bar magnets with their ends marked A to J can be arranged as shown below.

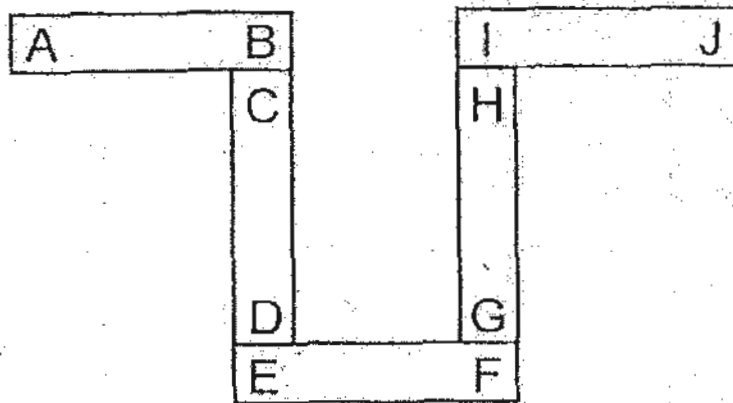

Which one of the following diagrams shows a possible arrangement of two of the magnets?

(1)

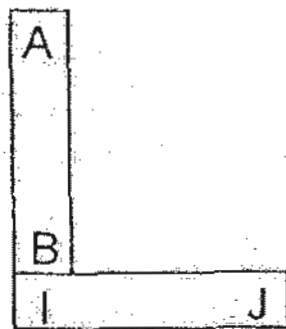

(2)

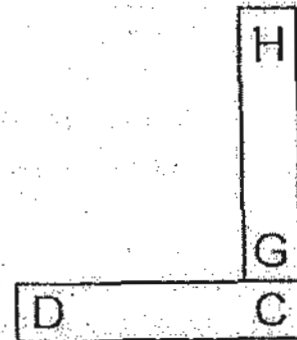

(3)

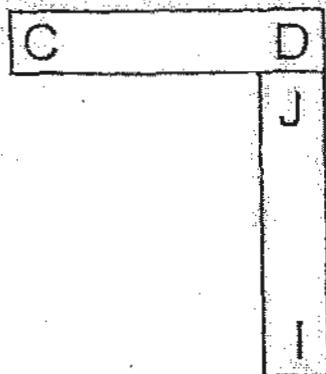

(4)

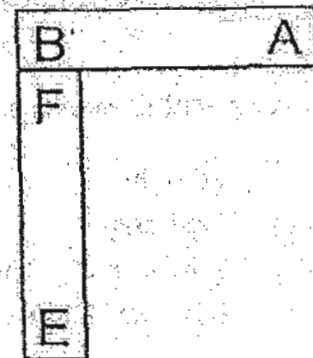

24. A datalogger was used to measure the amount of light passing through three different materials, S, T and U.

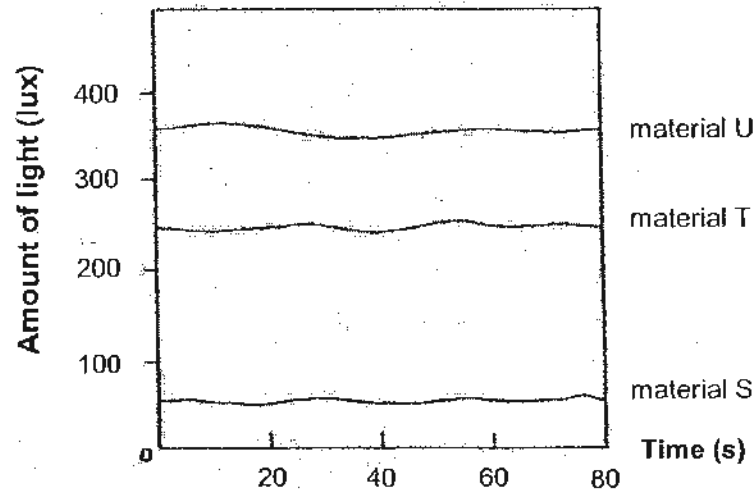

Which of the following best represent materials S, T and U?

	Material S	Material T	Material U
(1)	Writing paper	Tracing paper	Clear glass
(2)	Cardboard	Frosted glass	Clear glass
(3)	Writing paper	Cardboard	Frosted glass
(4)	Clear glass	Frosted glass	Cardboard

25. Three pupils made the following statements about human systems.

Sally Our skeletal and muscular systems help us in our movement.
Siti All of our body systems are equally important because they work together in order for us to survive.
Raja Our body can still function properly if our respiratory system breaks down because the circulatory system will still transport oxygen to all parts of our body.

Whose statement(s) is/are correct?

- (1) Siti only
 (2) Raja only
 (3) Sally and Siti only
 (4) Sally and Raja only

26. The diagram below shows four sets of identical balance with objects X, Y and Z placed on them.

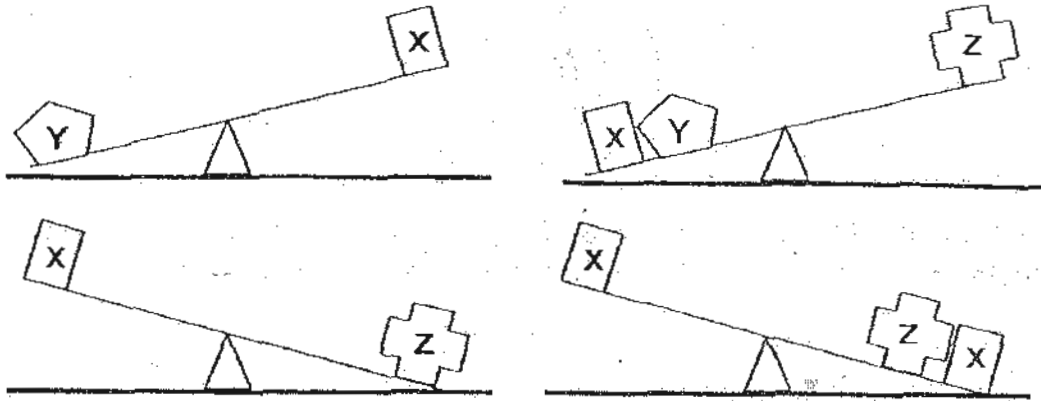

Based on the diagram above, which of the following statements are true?

- A Object X is lighter than object Z.
- B Object Y is heavier than object X.
- C Object Z is heavier than the total weight of objects X and Y.

- (1) A and B only
- (2) A and C only
- (3) B and C only
- (4) A, B and C

27. The diagram below shows a cooking pot.

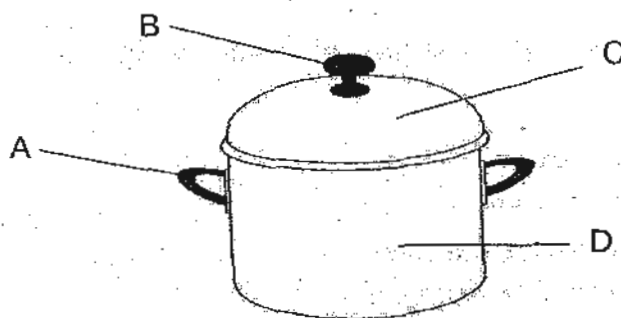

Which part(s) of the pot should **not** be a good conductor of heat?

- (1) A only
- (2) A and B only
- (3) B and C only
- (4) C and D only

- 28 The diagram below shows a compass at rest.

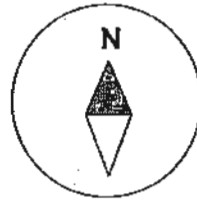

Jane placed the compass and an iron nail near the two ends of a strong bar magnet as shown below. The iron nail became a temporary magnet.

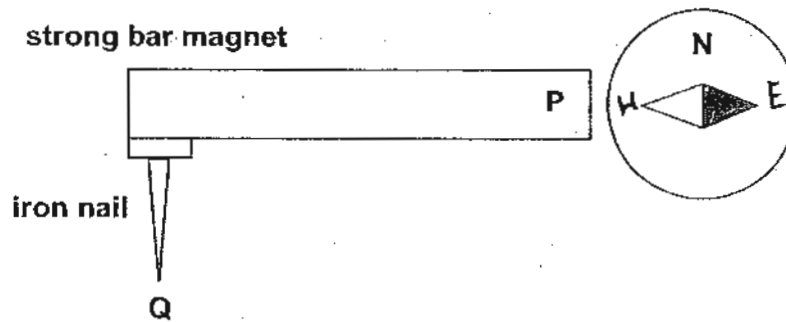

Which one of the following correctly represents the poles of P and Q?

	P	Q
(1)	South	South
(2)	North	North
(3)	North	South
(4)	South	North

29. Which of the following activities will give off heat and light energy at the same time?

- A Lighting a lantern
- B Igniting a fire cracker
- C Rubbing two hands together
- D Switching on the computer monitor

- (1) A and B only
- (2) C and D only
- (3) A, B and C only
- (4) A, B and D only

30. Micheal wants to find out if plants absorb water through their roots.

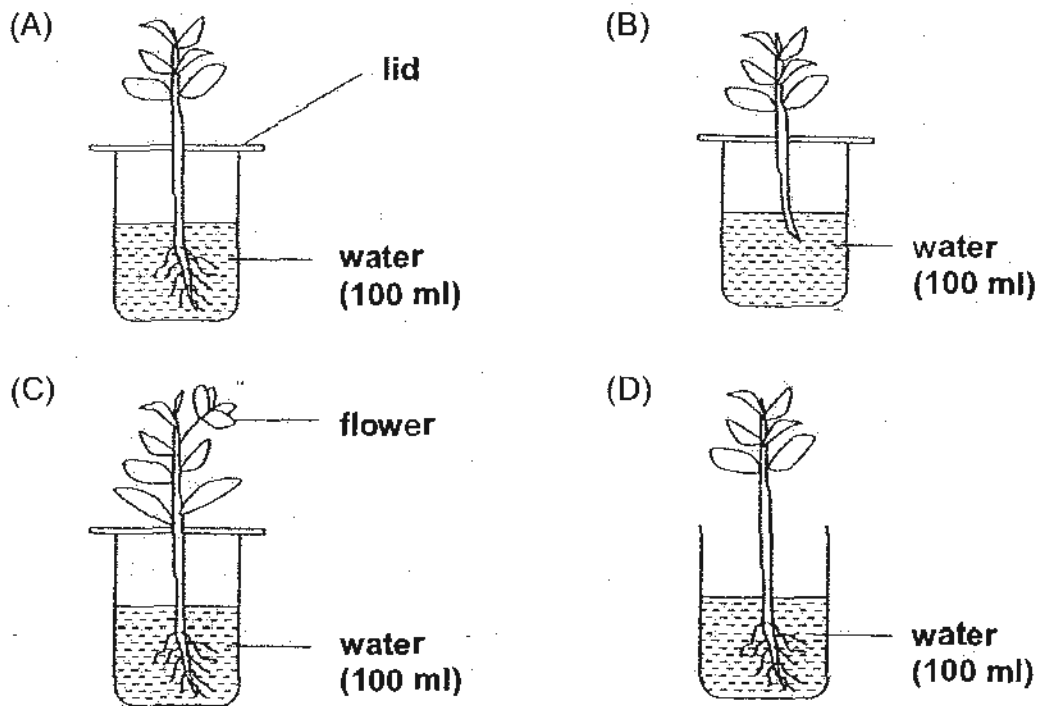

Which of the two set-ups above should he choose to conduct a fair test?

- (1) A and B only
- (2) A and D only
- (3) B and C only
- (4) B and D only

*****End of Paper*****

NAME : _____ ()

CLASS: PRIMARY 4 _____

CHIJ ST NICHOLAS GIRLS' SCHOOL



Second Semestral Assessment

2010

Primary 4 SCIENCE

(BOOKLET B)

2 November 2010

Total Time for Booklets A and B: 1 hour 45 minutes

14 questions
40 marks

Booklet A	60
Booklet B	40
Total	100

INSTRUCTIONS TO CANDIDATES

- Do not open this booklet until you are told to do so.
- Follow all instructions carefully.
- Answer all questions.

Parent's Signature/Date

This paper consists of 10 printed pages.

Section B : (40 marks)

For questions 31 to 44, write your answers in this booklet. The number of marks available is shown in bracket [] at the end of each question or part question.

31. The diagram below shows a caterpillar feeding on a leaf.

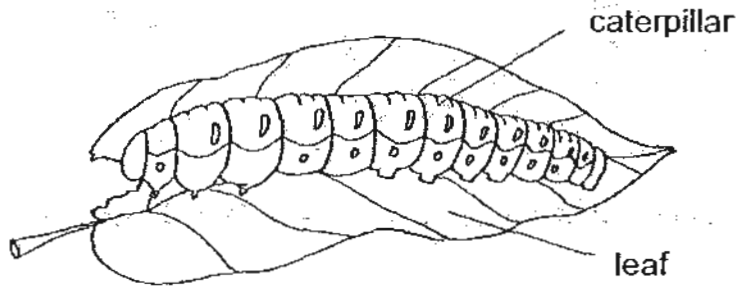

(a) Besides food, what does the caterpillar need in order to stay alive? [2]

(i) _____

(ii) _____

(b) After a week of feeding, the caterpillar above becomes longer. [1]

This shows that it can _____.

32. Choose the correct words from the box to answer the question below. (You may use the same word more than once.)

gullet	large intestine	stomach	small intestine	mouth
--------	-----------------	---------	-----------------	-------

In a human digestive system, name the part where

(a) digestion first takes place : _____ [2]

(b) digestion is completed : _____

33. The diagram below shows Mr Lee's car.

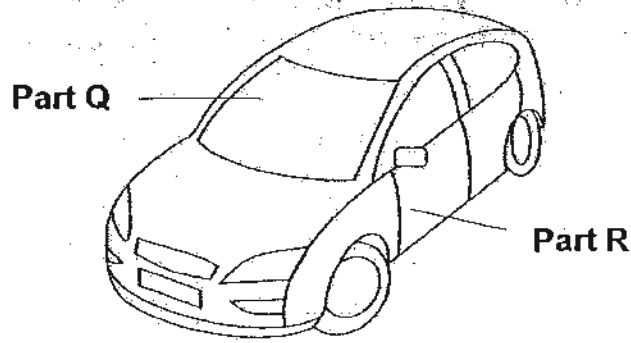

(a) Name a suitable material for making Part Q and R of the car. [2]

(i) Part Q - _____

(ii) Part R - _____

(b) The material for part Q is chosen because it allows _____ to pass through so that Mr Lee can see the road. [1]

34. The diagram below shows two plants.

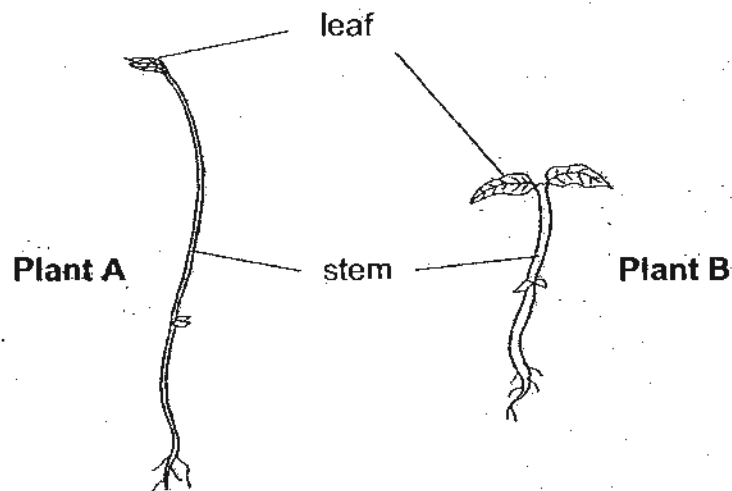

(a) Based what you can see from the diagram above, state one difference between the stem of plant A and the stem of plant B. [1]

(b) The leaves help both plants make _____ in the light. [1]

35. Jessica used an instrument to measure the temperature of water in a glass as shown in the diagram below.

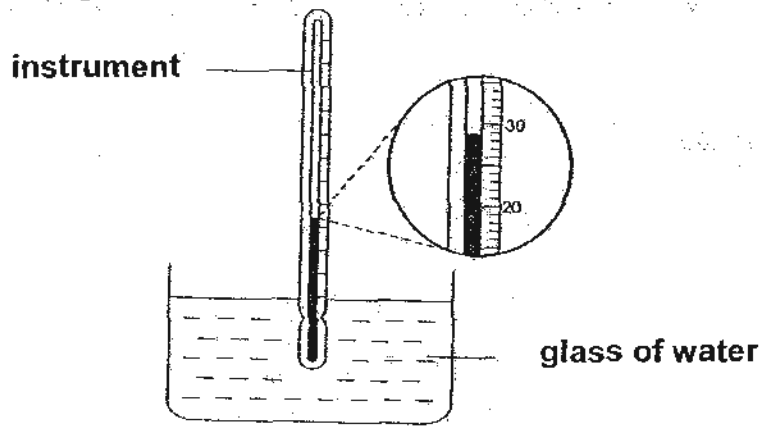

- (a) Name the instrument. [1]

- (b) What is the temperature of the water in the glass? [1]

_____ °C

36. Desmond carried out an experiment to find out which material used for making cups that can keep boiling water hot for the longest time. The table below shows the three types of materials he used in his experiment.

	Cup A	Cup B	Cup C
Material	Steel	Styrofoam	Paper

- (a) Name two variables that Desmond should keep the same in order to conduct a fair test. [1]

Variable 1: _____

Variable 2: _____

- (b) Which material should he use for making cup that can keep boiling water hot for the longest time? [1]

37. Patricia made a magnet using the electrical method.

(a) Draw the wire in the diagram below to show how she set up the experiment. [2]

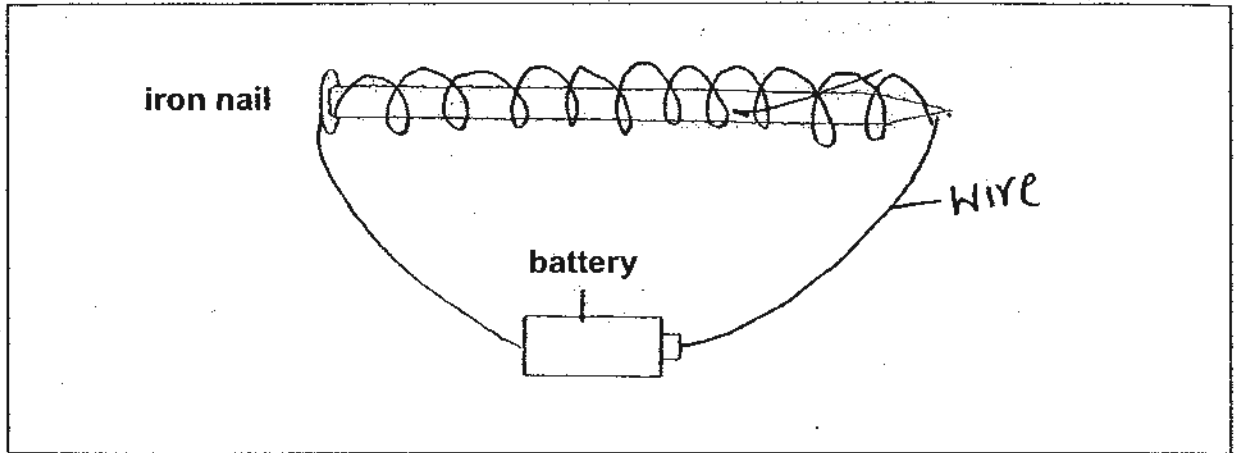

She repeated her experiment a few times with a different number of batteries. The table below shows the results of her experiment.

Number of batteries	Number of pins picked up by the nail
1	3
2	7
3	12
4	15

(b) What is the relationship between the number of batteries and the number of pins picked up by the nail? [1]

(c) State another way to increase the number of pins picked up by the nail. [1]

38. The diagrams below show the different stages in the life cycles of animal V and W.

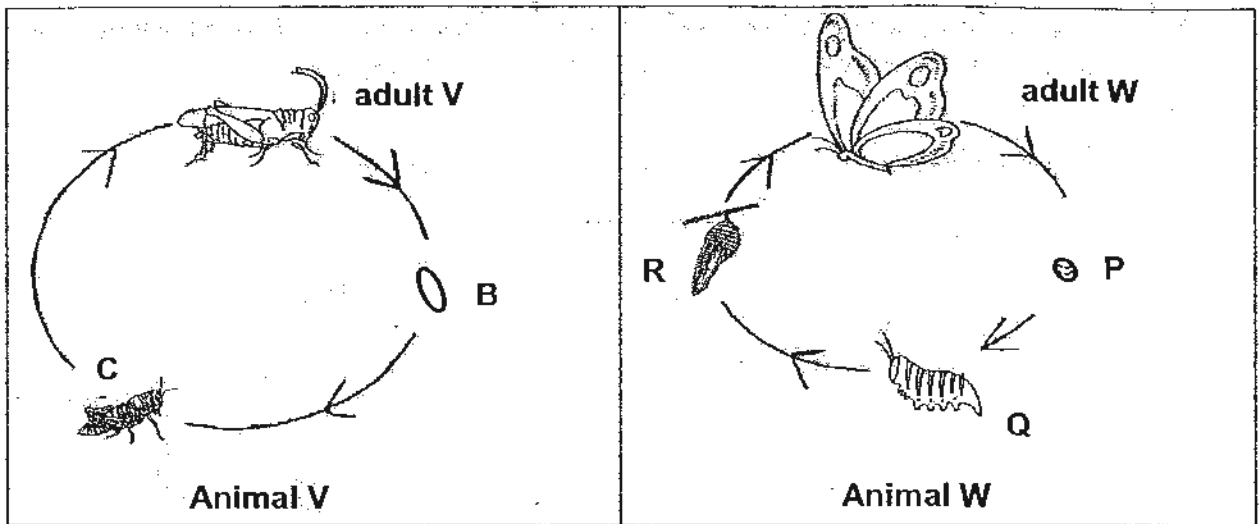

(a) Identify Q.

[1]

(b) Based on the above diagram, state one difference between the life cycles of animals V and W.

[1]

39. Matter expands when heated. The diagram below shows a bimetallic strip that is made up of metal A and metal B. When heated, the piece of metal bends as shown in the diagram below.

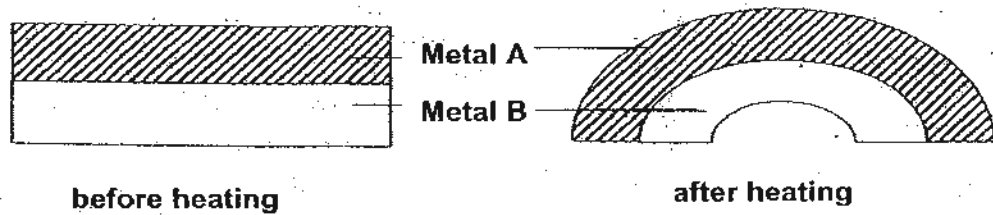

(a) Explain why the strip bent as shown when heated.

[1]

(b) What difference can be observed between metal A and B if they are not joined together when heated?

40. Larry placed a ping pong ball and a large square piece of wood between a lighted torch and the screen in a straight line as shown below.

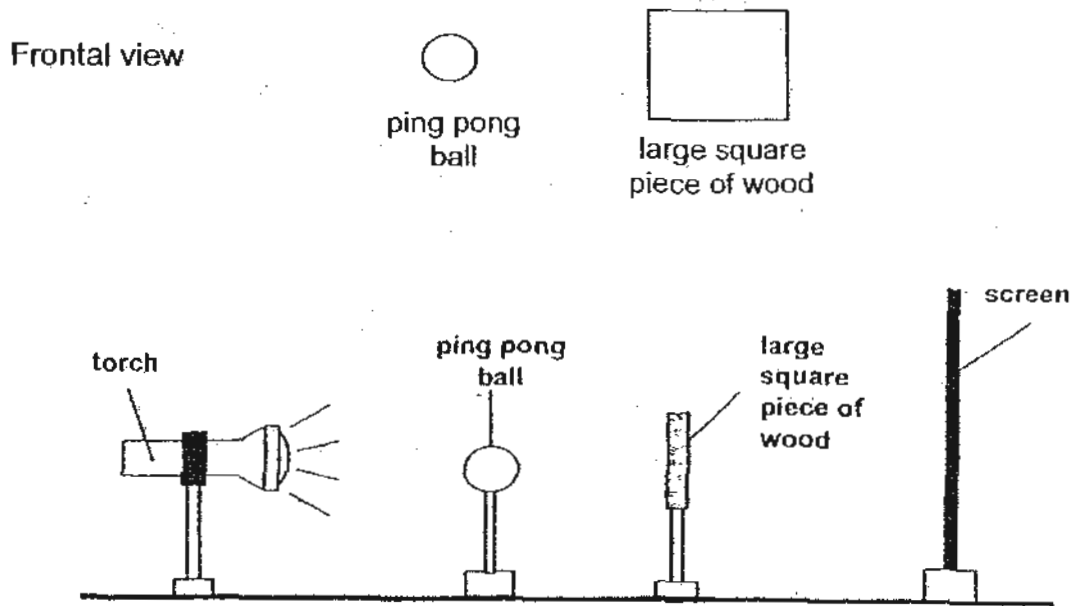

Larry saw a dark shadow cast on the screen.

- (a) Draw and shade the shadow that Larry saw on the screen in the box given below. [1]

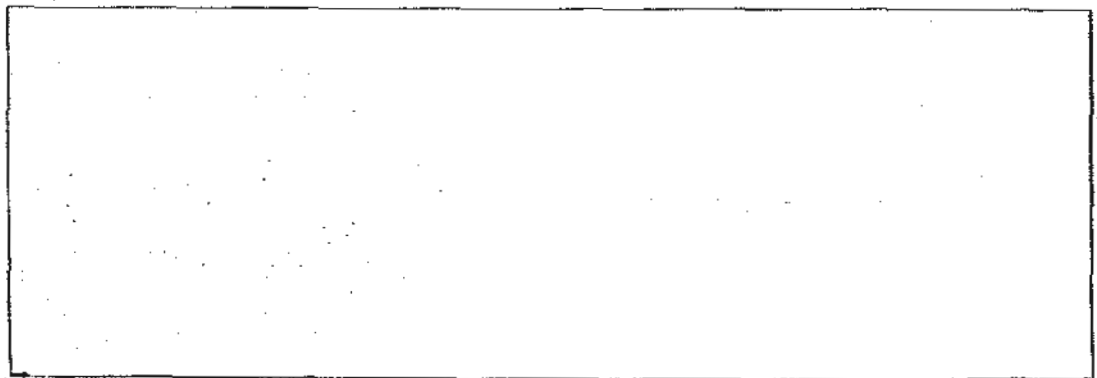

- (b) Explain how the shadow is formed on the screen.

- (c) Will the shape of the shadow cast on the screen be the same if we switch the positions of the ping pong ball and the large square piece of wood? Explain your answer. [1]

41. A piece of aluminium foil and thick towel were placed on the table. Jasmine placed one hand on the aluminium foil and the other on the towel as shown in the diagram below.

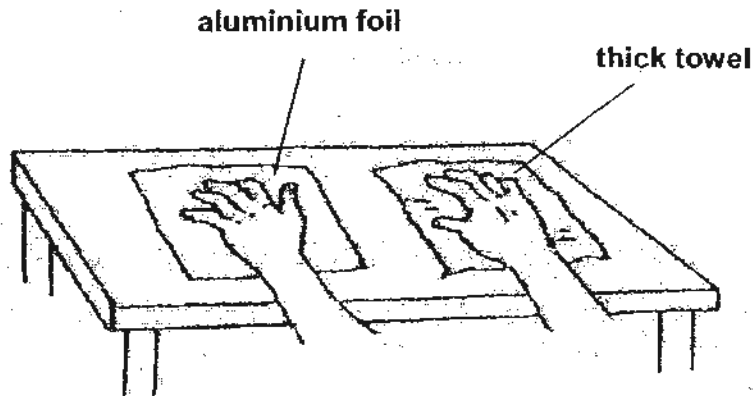

- (a) If both the aluminium foil and the thick towel are at room temperature, which piece of material will feel colder to Jasmine's hand? [1]

- (b) Explain your answer in (a). [1]

- (c) If the same experiment is carried out under the sun, which piece will feel hotter to Jasmine's hand? Explain your answer. [2]

42. Mrs Tan made a hole on a can of condensed milk as shown below.

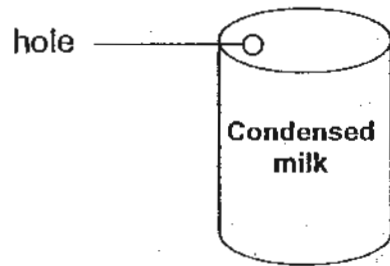

She tried pouring the milk out but found that it flowed out very slowly.

- (a) Without enlarging the hole or opening the can, suggest a way to allow the condensed milk to flow out faster. [1]

- (b) Explain how your suggestion in (a) would enable the milk to flow out faster. [2]

43. Grace heated an iron block to 90°C . She then put the iron block into a basin containing water at 50°C as shown in the diagram below.



Complete the table below.

(4m)

		Change in temperature (state whether increase or decrease)	Explain what caused the change in temperature.
(a)	Water		
(b)	Iron block		

44. Study the set up below.

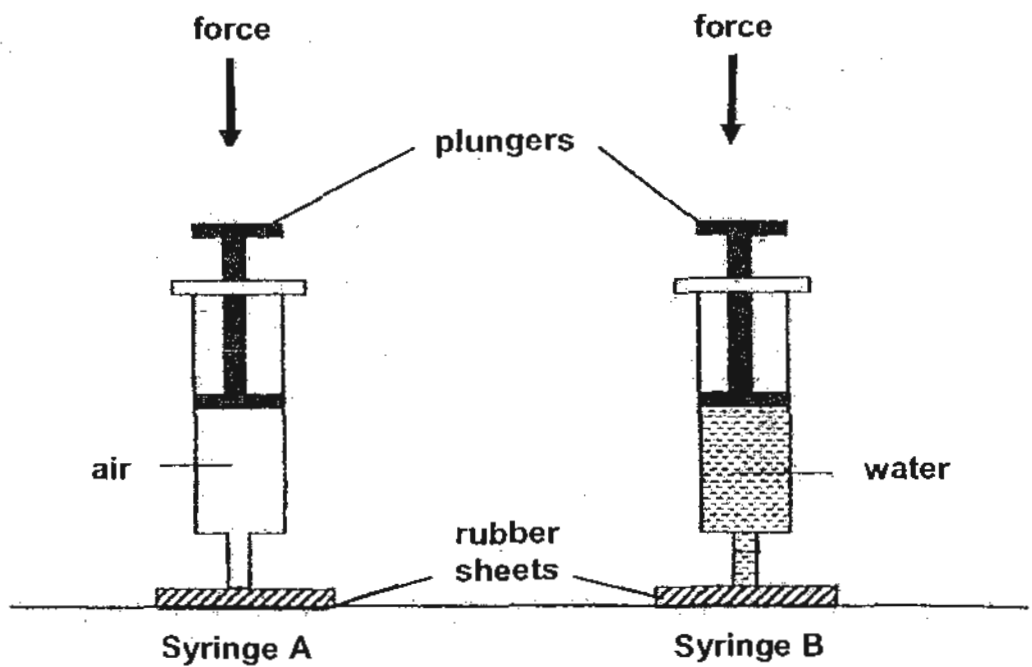

(a) What will happen if the plungers of both syringes are pushed in with the same amount of force at the same time? [2]

(b) Explain your answer in (a). [2]

****End of Paper****

ANSWER SHEET

EXAM PAPER 2010

SCHOOL : CHIJ ST NICHOLAS GIRLS' SCHOOL
SUBJECT : PRIMARY 4 SCIENCE

TERM : SEMESTRAL ASSESSMENT 2

Q1	Q2	Q3	Q4	Q5	Q6	Q7	Q8	Q9	Q10	Q11	Q12	Q13	Q14	Q15	Q16	Q17
2	4	2	4	1	3	1	4	2	2	4	2	3	2	4	4	2

Q18	Q19	Q20	Q21	Q22	Q23	Q24	Q25	Q26	Q27	Q28	Q29	Q30
2	4	1	3	2	1	1	3	1	2	3	4	1

Q31ai) Air
ii) Water
b) grow

Q32a) mouth
b) small intestine

Q33ai) Part Q—Glass
ii) Part R—Metal
b) light

Q34a) The stem of plant A is thin while the stem of plant B is thicker.
b) food

Q35a) A thermometer
b) 29°C

Q36a) Variable 1: Thickness of the cups.
Variable 2: Amount of water poured into the cups.
b) Styrofoam

Q37a)

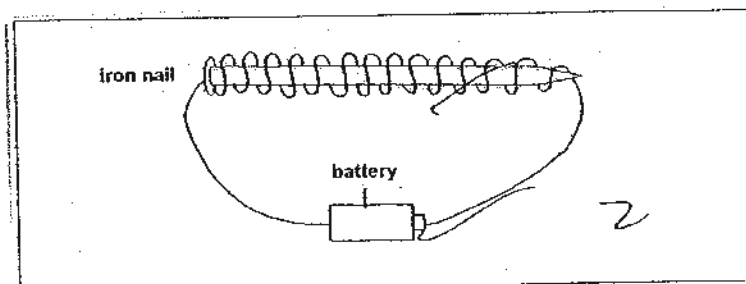

b) The more the number of batteries, the more pins are picked up by the nail.
c) Increase the number of coils around the nail.

Q38a) A caterpillar.

b) The life cycle of Animal V has 3 stages but the life cycle of Animal W has 4 stages.

Q39a) Metal A expanded more than Metal B.

b) Metal A will be longer than Metal B.

Q40a)

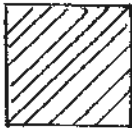

b) Light was blocked by the piece of wood.

c) Yes. The ping pong ball is smaller than the piece of wood and it allows more light to pass through it.

Q41a) The aluminum foil

b) Aluminum foil is a better conductor of heat than the towel, so it conducts heat faster away from the palm.

c) The aluminum foil. Heat travels faster through the aluminum foil than the thick towel.

Q42a) He can make more holes.

b) The milk can escape from one hole and air can enter through the other hole.

Q43)

		Change in temperature (state whether: increase or decrease)	Explain what caused the change in temperature.
(a)	Water	Increase	The water gains heat from the hot iron block.
(b)	Iron block	Decrease	The iron block loses heat to the water and the basin.

Q44a) The plunger of syringe A will go down but the plunger of syringe B will remain at the same position.

b) Syringe A is filled with air while Syringe B is filled with water. As air can be compressed, the plunger of syringe A will go down. The plunger of syringe B will remain the same as water cannot be compressed.