

ANGLO-CHINESE SCHOOL  
(JUNIOR)



SEMESTRAL ASSESSMENT 1 (2010)  
PRIMARY 5

SCIENCE

BOOKLET A

Friday

14 May 2010

1 hour 30 minutes

Name : \_\_\_\_\_ (      )

Class : P5 \_\_\_\_\_

**INSTRUCTIONS TO PUPILS**

**DO NOT TURN OVER THE PAGES UNTIL YOU ARE TOLD TO DO SO**

Follow all instructions carefully.

There are 25 questions in this booklet.

Answer **ALL** questions.

**INFORMATION FOR PUPILS**

The total marks for this booklet is 50.

The total time for Booklets A and B is 1 hour 30 minutes.

This question paper consists of 16 printed pages. (Inclusive of cover page)

Section A (50 marks)

For each question from 1 to 25, four options are given. One of them is the correct answer. Choose the correct option (1, 2, 3 or 4) and shade the correct oval on the Optical Answer Sheet (OAS) provided.

- 1 David wanted to investigate how the amount of light affects the growth of a type of plant. The diagrams below show each of his set-ups in a clear glass tank.

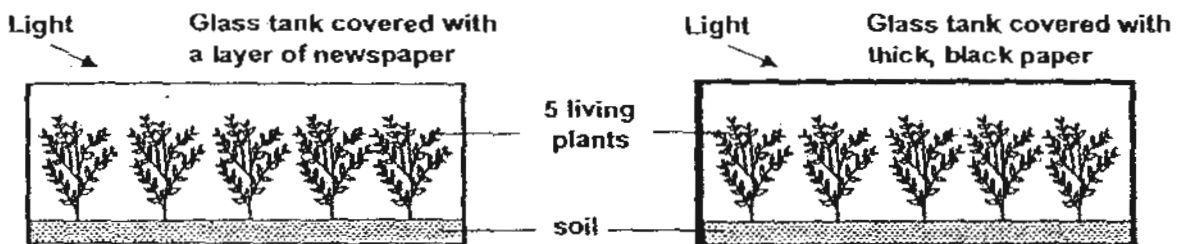

Which one of the following set-ups can he use as a control for his experiment?

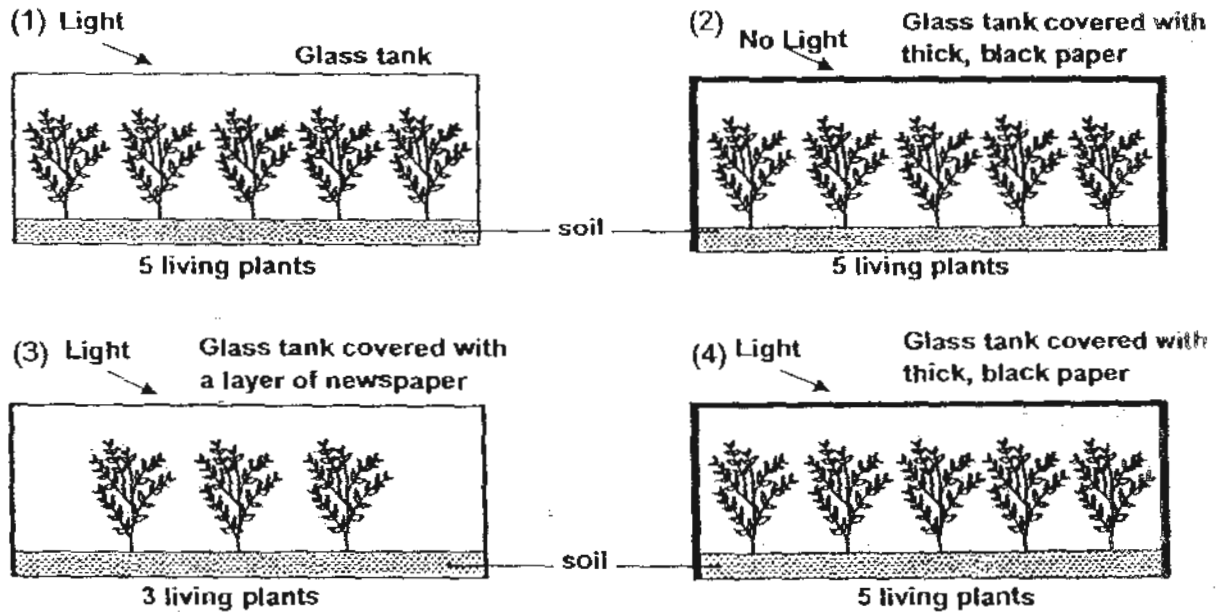

2 Study the following information collected on Animal X.

- It has feathers on its body.
- It is a flightless domesticated animal.
- It is an egg-laying animal and takes care of its young.
- It uses its beak to prod into the ground to look for worms, grubs and berries.

Based only on the information collected, we can conclude that Animal X \_\_\_\_\_

- (1) is a duck.
- (2) hops to move around
- (3) is an omnivorous animal.
- (4) feeds its young with milk.

3 Four bean seedlings that have roots about 2cm long are grown in different positions.



After a few days, the seedlings are observed again. Of the 4 seedlings, A, B, C or D shown above, which seedling(s) will have roots growing downwards?

- (1) B only
- (2) A and D only
- (3) A, B and C only
- (4) A, B, C and D

4 Which one of the following animals does not have the same number of stages in its life cycle as the rest of the animals?

(1)



Housefly

(2)



Cockroach

(3)



Lizard

(4)



Toad

5 Four plastic bottles, A, B, C and D, had their bases cut off and were immersed into a container filled with water as shown in the picture below.

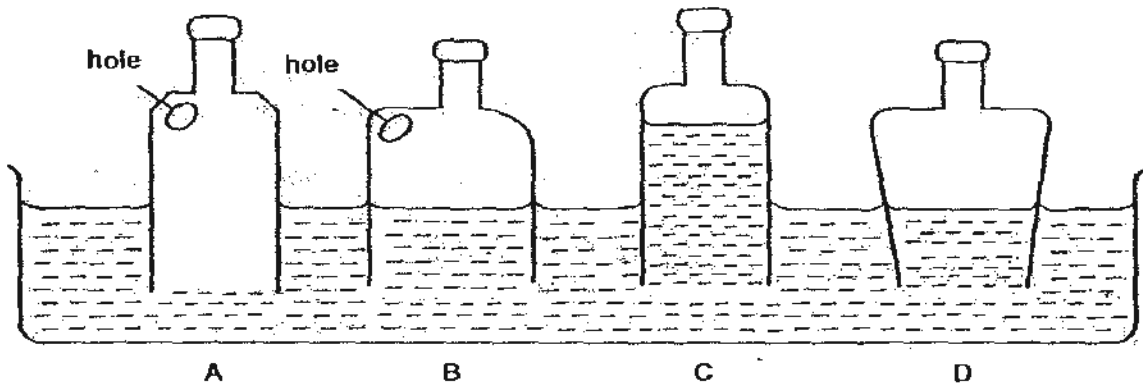

Which one of the bottles accurately shows the correct level of water in it?

- (1) A
- (2) B
- (3) C
- (4) D

6 Refer to the diagram of the human digestive system. At which part A, B, C or D is the digestion of food completed?

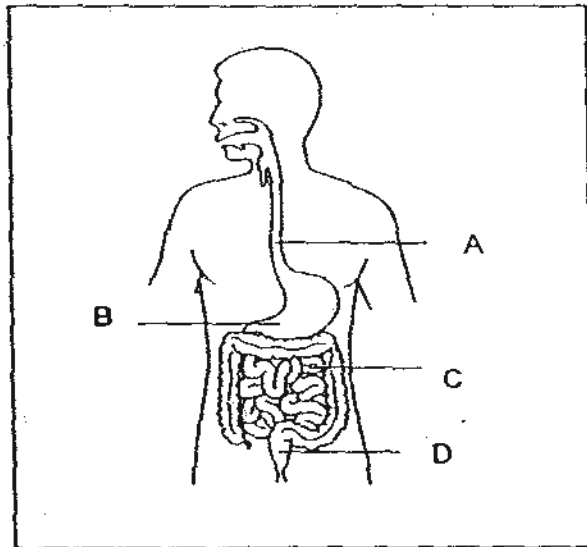

- (1) A
- (2) B
- (3) C
- (4) D

7 Study the plant below carefully.



Which of the following statements about the stem of this plant are correct?

- A: They hold the plant firmly to the ground.
- B: They enable the leaves to get maximum sunlight.
- C: They carry food, water and mineral salts to all plant parts.

- (1) A and B only
- (2) B and C only
- (3) A and C only
- (4) A, B and C

8 The diagram below shows a cross section of the stem of a plant. Which labeled part A, B, C or D is responsible for the transportation of food?

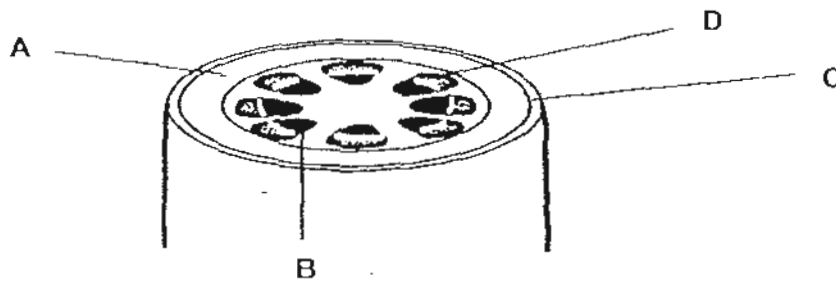

- (1) A
- (2) B
- (3) C
- (4) D

- 9 Which of the following describes what happens to the different parts of the respiratory system when we breathe in?

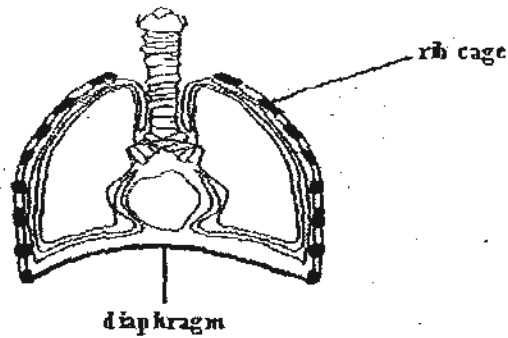

(1)	in and downwards	upwards	contracts
(2)	in and upwards	downwards	expands
(3)	out and downwards	upwards	contracts
(4)	out and upwards	downwards	expands

- 10 Four blood samples were taken from different blood vessels in the body. The following graph shows the amount of oxygen in each of the blood samples.

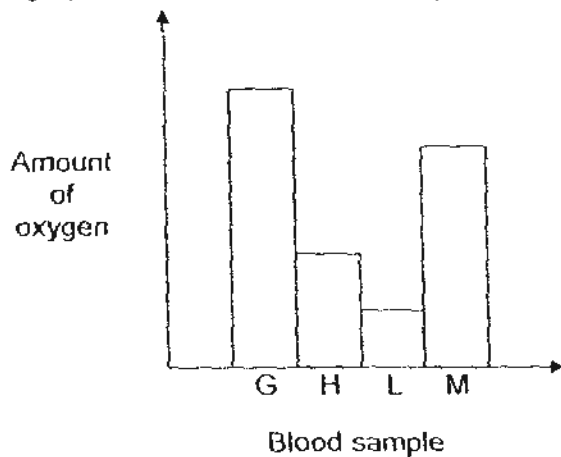

Which one of the blood samples is most likely to have been taken from the blood vessel carrying blood from the heart to the lungs?

- (1) G
- (2) H
- (3) L
- (4) M

- 11 The table below provides some information on three cells, P, Q and R. A tick (✓) indicates the presence of the part of a cell.

Parts of a cell	Cells		
	P	Q	R
Nucleus	✓	✓	✓
Cell Membrane	✓	✓	✓
Cytoplasm	✓	✓	✓
Cell Wall	✓		✓
Chloroplast			✓

Where are cells P, Q and R likely to be found?

	Cell P	Cell Q	Cell R
(1)	cheek	root	leaf
(2)	leaf	cheek	root
(3)	root	cheek	leaf
(4)	root	leaf	cheek

- 12 Which of the following processes show that heat is absorbed by water?

- A: Water droplets forming on the surface of a car
- B: A puddle of water on the road reducing in volume.
- C: A bottle of boiling water left in an air conditioned room.

- (1) B only
- (2) A and C only
- (3) B and C only
- (4) A, B and C

- 13 Mei Ling set up the circuit as shown below, with two bulbs, B1 and B2 and four switches, S1, S2, S3 and S4. Mei Ling wanted to investigate which bulb(s) would light up when the various switches were opened and closed.

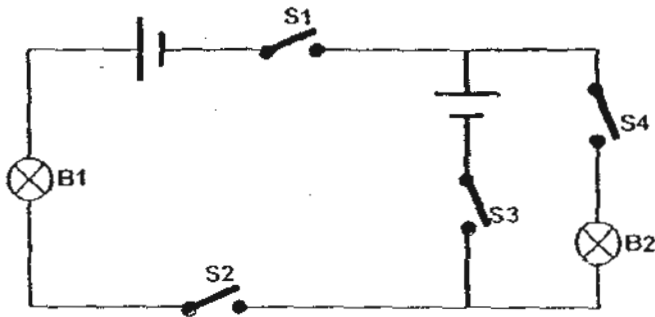

Which of the following corresponds with the outcome?

	S1	S2	S3	S4	B1	B2
(1)	open	open	closed	closed	yes	no
(2)	closed	closed	open	closed	no	yes
(3)	closed	open	closed	open	no	yes
(4)	closed	closed	closed	open	yes	no

- 14 Bacteria and fungi are similar in that both of them \_\_\_\_\_

- A: reproduce from spores
- B: are microscopic organisms
- C: are neither plant nor animal

- (1) C only
- (2) A and B only
- (3) B and C only
- (4) A, B and C

15 Study the following circuits carefully.

Circuit A

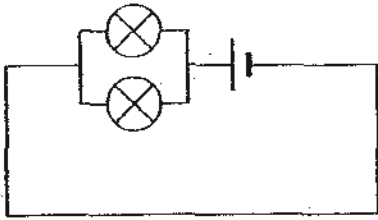

Circuit B

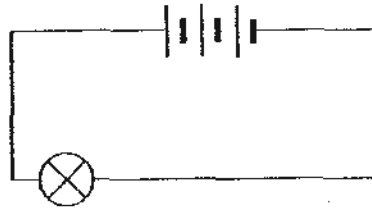

Circuit C

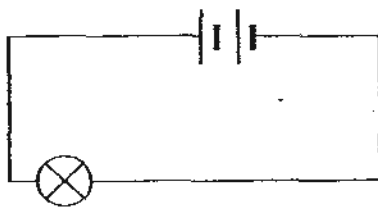

Circuit D

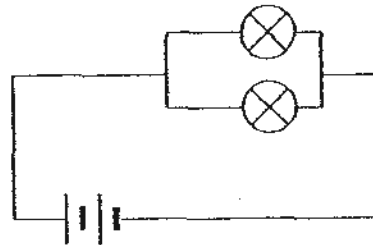

The bulbs in set-ups \_\_\_\_\_ will be of the same brightness.

- (1) A and B
- (2) A and C
- (3) B and D
- (4) C and D

16 Siva wanted to investigate if the arrangement of batteries would affect the strength of electric current flowing in a circuit. Which of the following set-ups should he use to ensure this investigation is a fair one?

Set-Up A

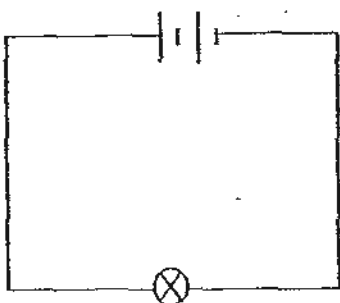

Set-Up B

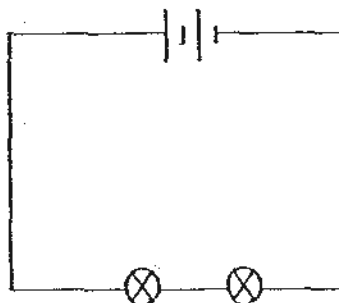

Set-Up C

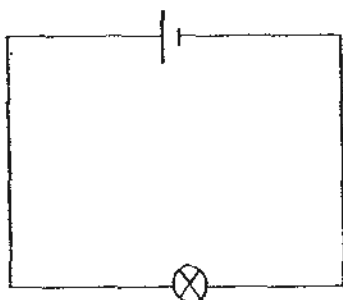

Set-Up D

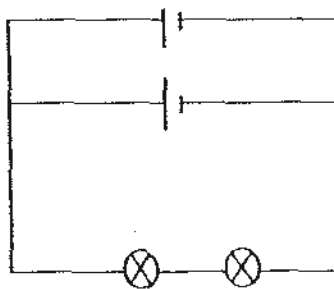

- (1) A and B
- (2) A and C
- (3) B and D
- (4) C and D

17 Objects A, B, C, D, E and F are of the same size and shape but are made of different materials.

The table below states the amount of light that can pass through each object.

	Does not allow light to pass through	Allows some light to pass through	Allows most light to pass through
Object	A	C	E
	B	D	F

Each object is placed between a torch and a wall.

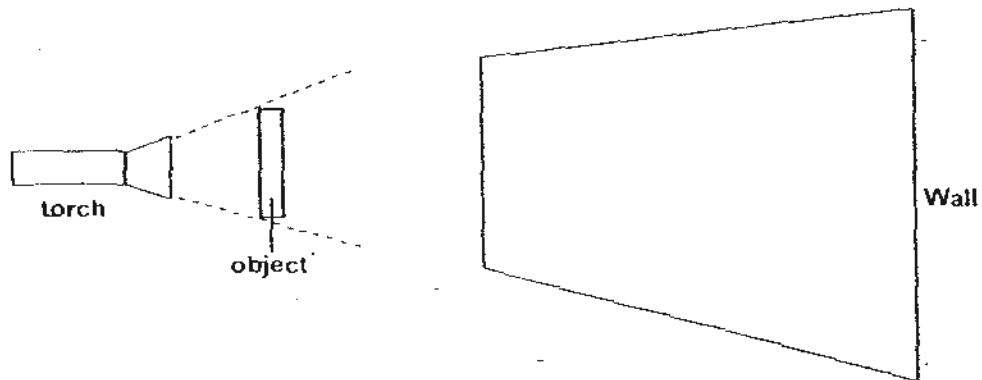

Which one of the following is true?

- (1) Object A forms a darker shadow than B.
- (2) Object F forms a darker shadow than B.
- (3) Object E forms a lighter shadow than C.
- (4) Object F forms a darker shadow than D.

18 Joshua wanted to find out whether plastic or styrofoam is a better insulator of heat.

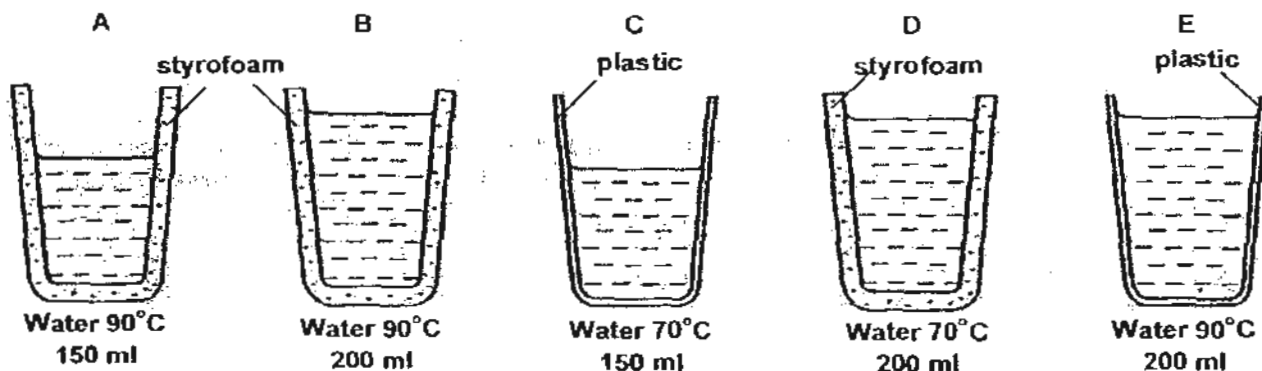

Which of the 2 set-ups should he use?

- (1) A and B only
- (2) A and C only
- (3) D and E only
- (4) B and E only

19 Janet heated a beaker of water over a flame. Ten minutes later, the water started to boil. She then switched off the flame and allowed the beaker of water to cool. Which graph below shows correctly the change in temperature of the beaker of water?

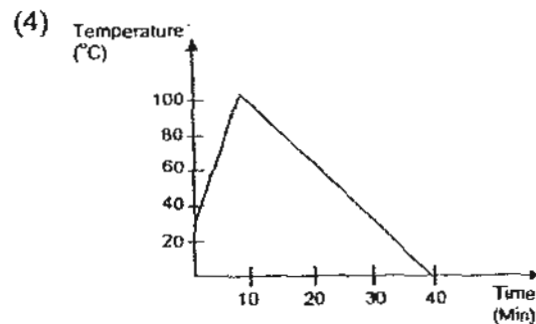
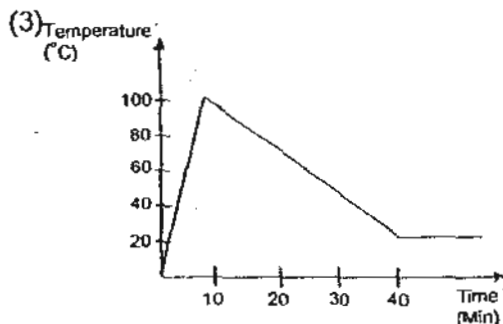
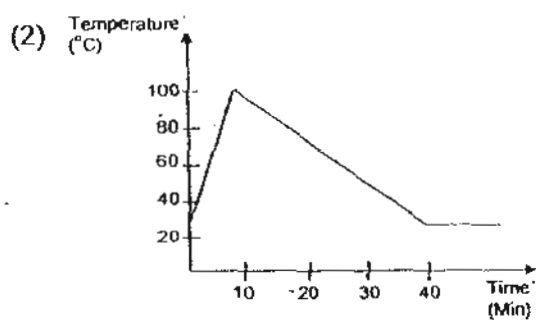
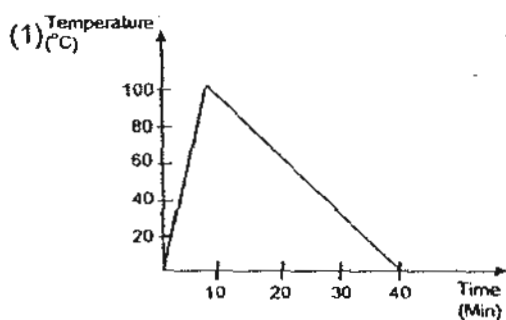

20 Four identical bar magnets are arranged as shown below.

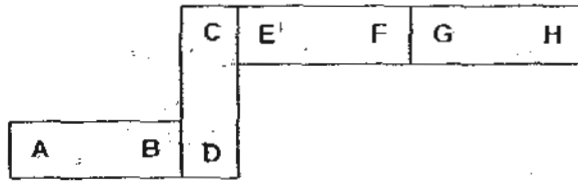

Which of the following diagrams shows the correct arrangement when 2 of the bar magnets are placed together?

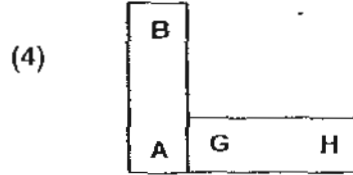
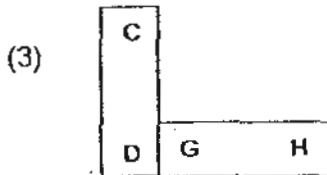
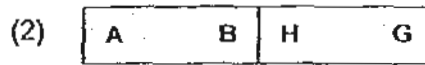
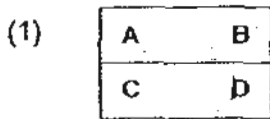

21 Study the diagram below.

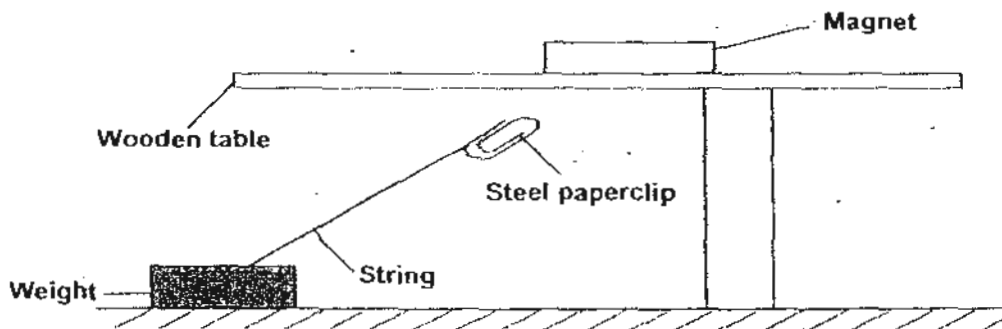

Based only on the experiment, what can you conclude?

- A: Wood is a non-magnetic material.
- B: Magnetic force can act at a distance.
- C: The paper clip is attracted to the magnet.
- D: The paper clip is made of a non-magnetic material.

- (1) A and D only
- (2) C and D only
- (3) A, B and C only
- (4) A, B, C and D

- 22 Damien had four magnets, A, B, C and D, which he placed at different distances from the tray of iron thumbtacks as shown below.

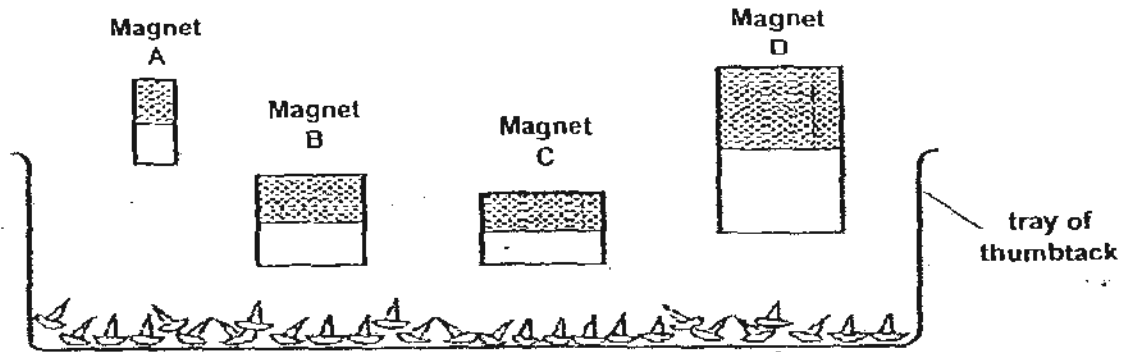

He observed and recorded the number of thumbtacks attracted to each magnet.

Number of thumbtacks attracted	Magnet A	Magnet B	Magnet C	Magnet D
	5	3	1	5

Based only on the results above, arrange the magnets from the strongest magnet to the weakest magnet.

- (1) A, D, B, C
- (2) D, A, C, B
- (3) C, B, A, D
- (4) B, C, D, A

- 23 Study the classification chart below.

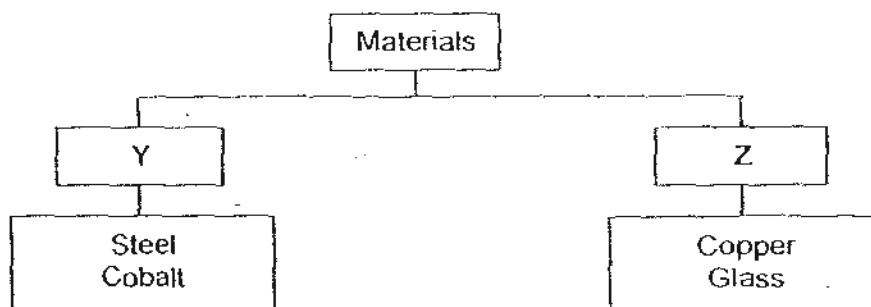

Determine a suitable heading for Y and Z.

(1)	Magnetic	Non-magnetic
(2)	Opaque	transparent
(3)	Poor conductors of heat	Good conductors of heat
(4)	Good conductors of electricity	Poor conductors of electricity

- 24 Darius wanted to test the strength of different parts of a bar magnet A, B, C and D by placing the magnet into a box of paper clips.

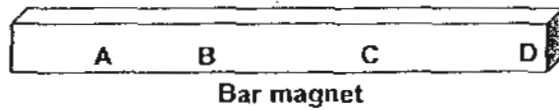

He then recorded his findings in a graph.

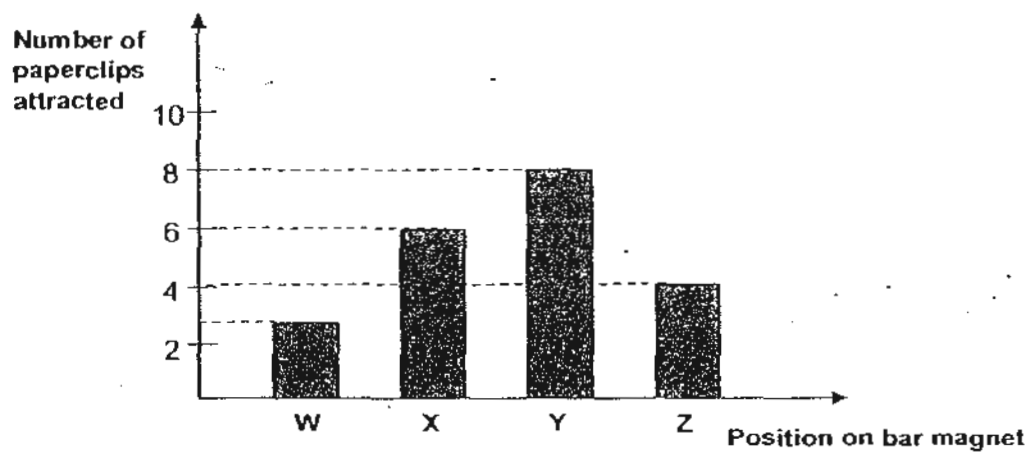

On which part of the bar magnet does column Y on the graph correspond to?

- (1) A
- (2) B
- (3) C
- (4) D

25 Figure 1 shows a traffic light circuit. Figure 2 shows the lights that lit up.

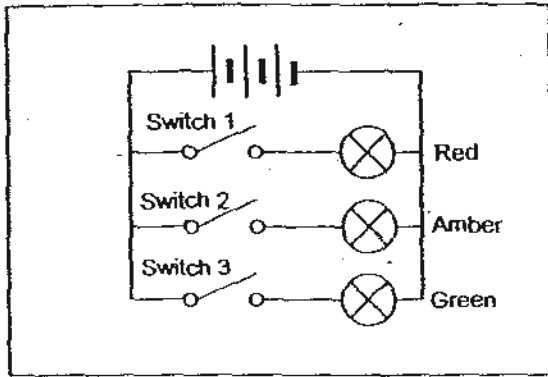

Figure 1

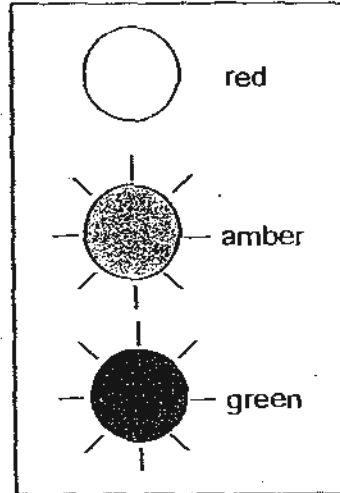

Figure 2

Which combination of switches must be closed in order for the lights in Figure 2 to be lit up?

	Switch 1	Switch 2	Switch 3
(1)	closed	open	open
(2)	open	closed	closed
(3)	open	open	closed
(4)	closed	closed	closed

ANGLO-CHINESE SCHOOL  
(JUNIOR)



SEMESTRAL ASSESSMENT 1 (2010)  
PRIMARY 5

SCIENCE

BOOKLET B

Friday

14 May 2010

1 hour 30 minutes

Name : \_\_\_\_\_ ( )

Class : P5 \_\_\_\_\_

INSTRUCTIONS TO PUPILS

**DO NOT TURN OVER THE PAGES UNTIL YOU ARE TOLD TO DO SO**

Follow all instructions carefully.

There are 14 questions in this booklet.

Answer **ALL** questions.

INFORMATION FOR PUPILS

The number of marks is given in brackets [ ] at the end of each question or part question.

The total marks for this booklet is 40.

The total time for Booklets A and B is 1 hour 30 minutes.

**This question paper consists of 14 printed pages. (Inclusive of cover page)**

BOOKLET A	/ 50
BOOKLET B	/ 40
TOTAL	/ 90
Parent's signature/ Date:	

**PART II (40 marks)**

For questions 26 to 39, write your answers in this booklet.

The number of marks available is shown in brackets [ ] at the end of each question or part question.

26 Study the animals A, B, C and D and answer the questions below.



a) State two characteristics of insects. [2]

---

---

---

b) Which of the animals A, B, C and D are insects? [1]

---

27 Fill in each blank with the most suitable word. [2]

There are systems that operate in our body. The \_\_\_\_\_ system supports the body, giving it a shape and protecting the \_\_\_\_\_ in the body. This system works together with the \_\_\_\_\_ system which helps the different parts of the body to move. Muscles often work in pairs, in which one muscle \_\_\_\_\_ while the other muscle relaxes.

Score	
-------	--

- 28 Daniel wanted to find out the effects of water on germination of seeds. He set up the experiment as shown below in the science laboratory. The setup was placed at the same location having room temperature and the seeds used were of the same kind.

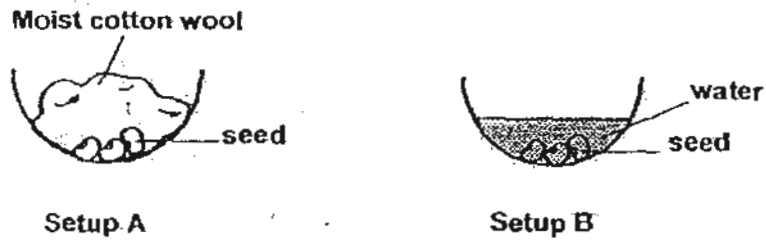

- a) Daniel realized that set-up B was incorrect. Draw and label what set-up B should look like. [2]

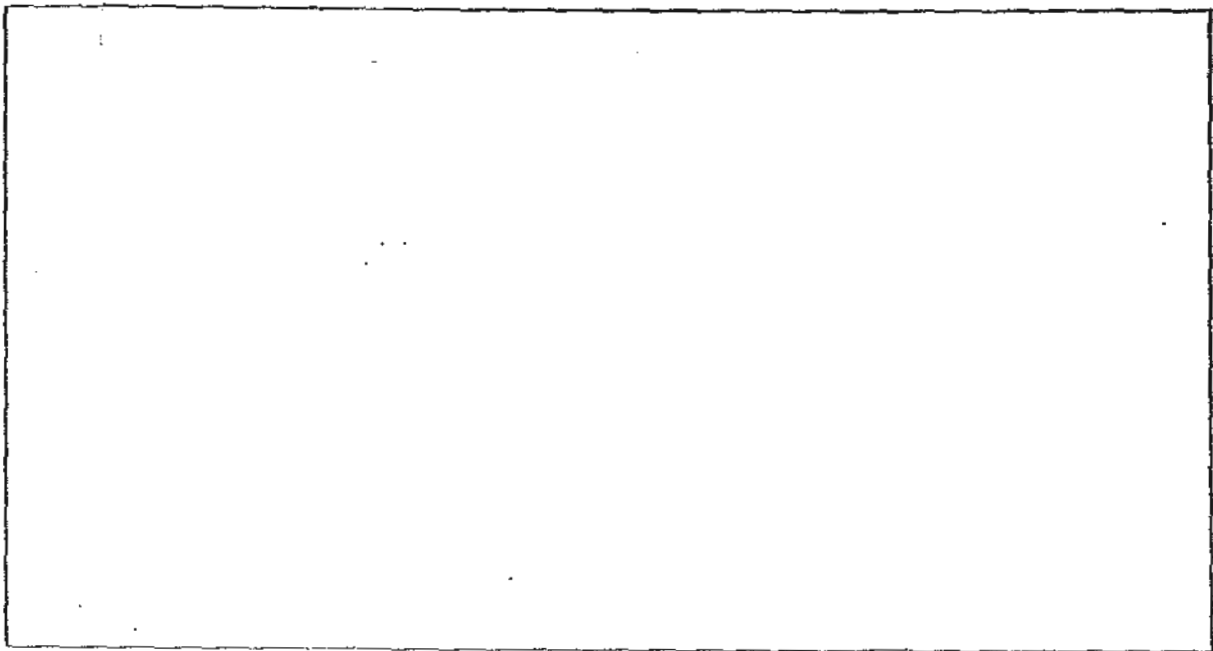

- b) State the conditions needed for the seeds to germinate. [1]

---

---

29 Andrew plucked a leaf from a plant and placed the underside of the leaf under a microscope. The diagram below shows what Andrew saw.

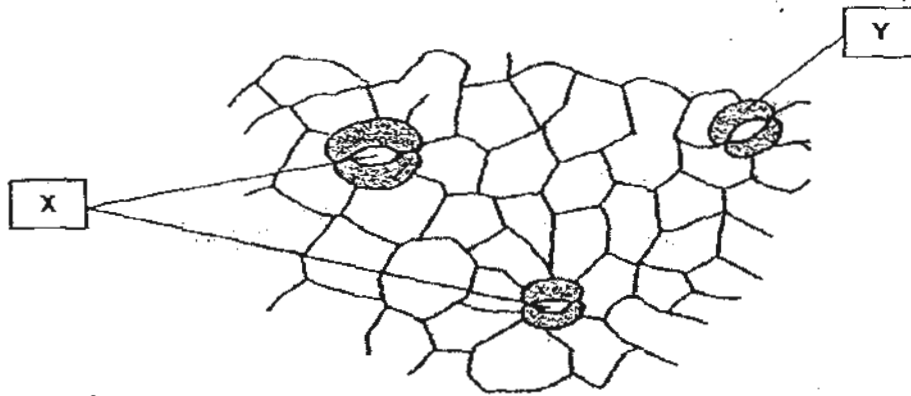

a) Name the parts [2]

Part X :

Part Y :

b) Explain the function of Part X [1]

---



---

30 The following diagram shows the exchange of gases in our circulatory system.

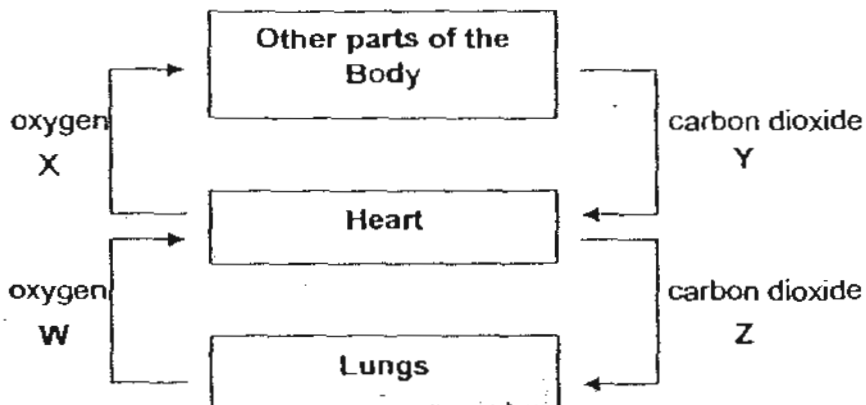

a) State which of the arrows W, X, Y or Z represents the arteries and veins. [1]

Arteries :

Veins :

The following graph shows the changes in the heart rate of a teenager as he exercises.

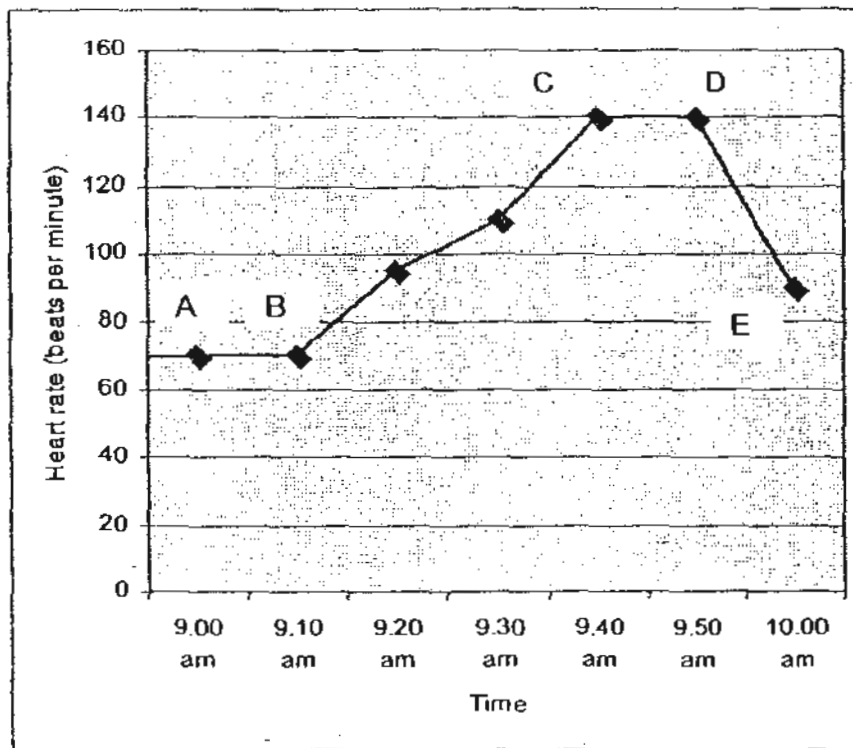

b) What was the fastest heart rate of the teenager? [1]

---

c) What happened to his heart rate from 9.50 a.m.? Why? [1]

---

---

---

---

31 The diagrams below show the reproduction of a yeast cell.

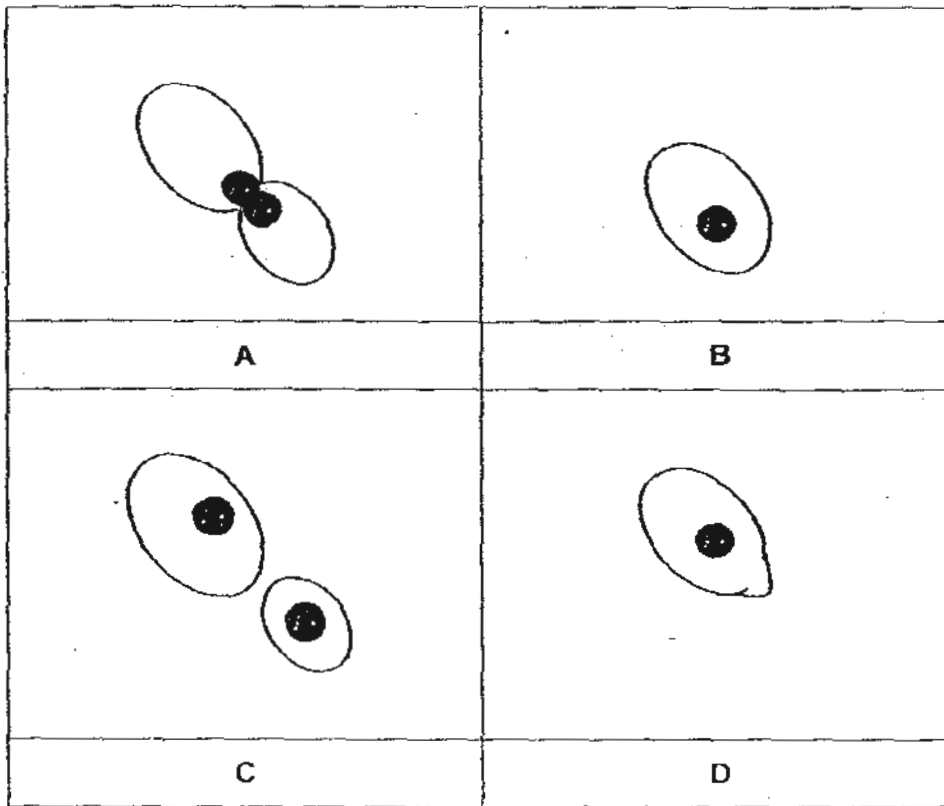

a) This process of reproduction is known as \_\_\_\_\_ [1]

b) Write the letters A, B, C and D to show the order in which this process takes place. [1]

--	--	--	--

start end

The following two diagrams represent what was seen through a microscope.

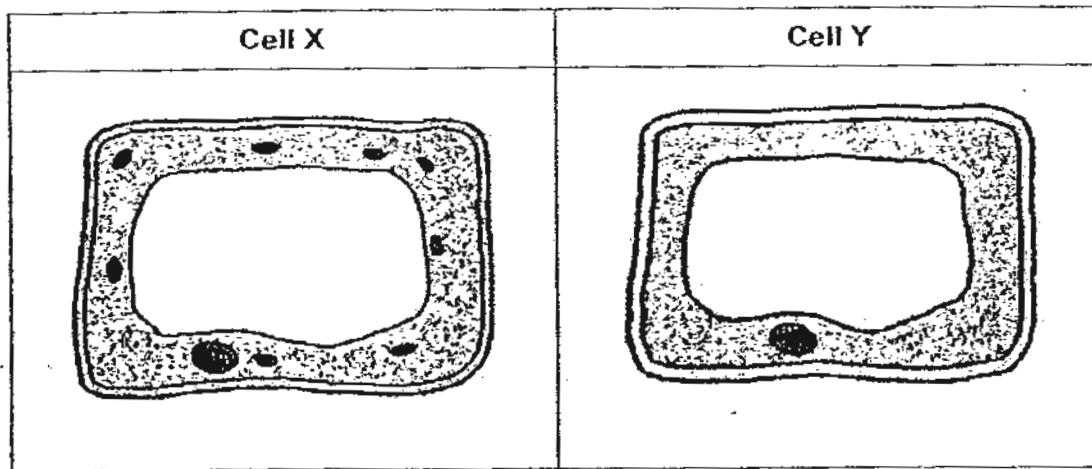

a) Referring to the diagrams, identify one similarity and difference between cells X and Y.

i) Similarity

[1]

---



---

ii) Difference

[1]

---



---

b) Cells X and Y are likely to be \_\_\_\_\_ cells because \_\_\_\_\_

[1]

---



---

33 The following diagram shows 4 set-ups where similar bulbs, batteries and wires were used. Study the circuits carefully and complete the table.

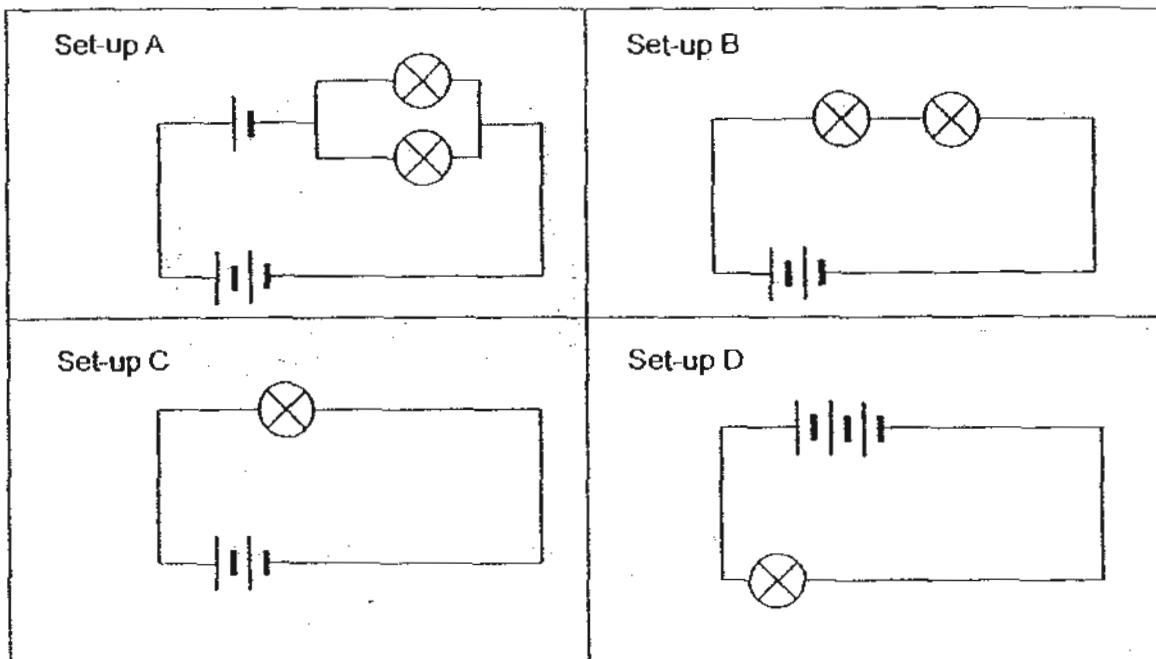

a) Read the following statements and tick (✓) the appropriate option for each statement. [2]

	Statements	True	False	Not able to tell
i	The bulbs of set-up A is brighter than the bulb of set-up C			
ii	The bulb of set-up D is the brightest of all the circuits			
iii	The bulb of set-up C is brighter than the bulbs of set-up B			
iv	Of the four circuits, the bulb in Set-up B will be the first to blow			

b) Sally was given 2 bulbs and 3 batteries. She was to set up a circuit where the bulbs lit up very brightly. Draw Sally's circuit diagram. [2]

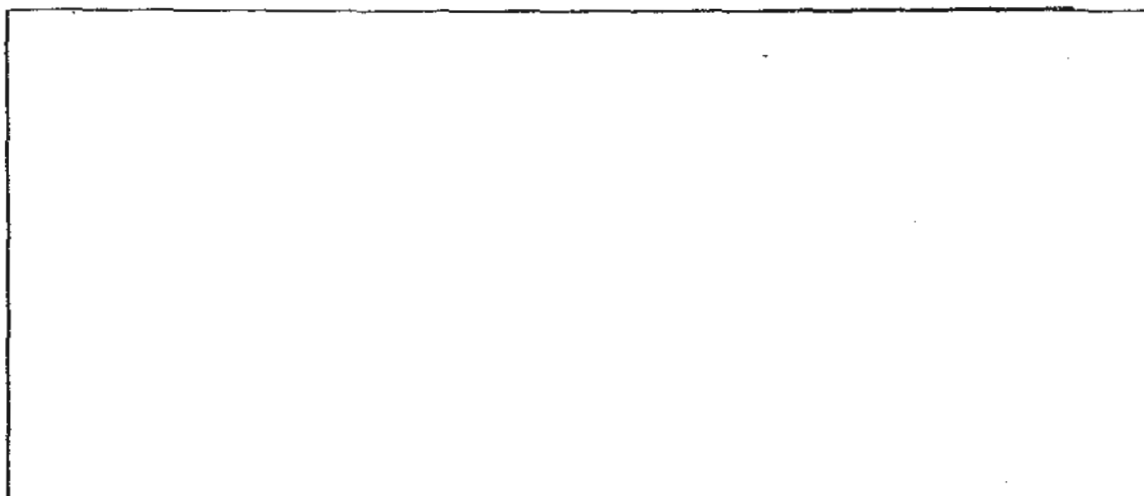

The diagram below shows a circuit with 3 different non-metal rods of the same size connected to three batteries and one bulb.

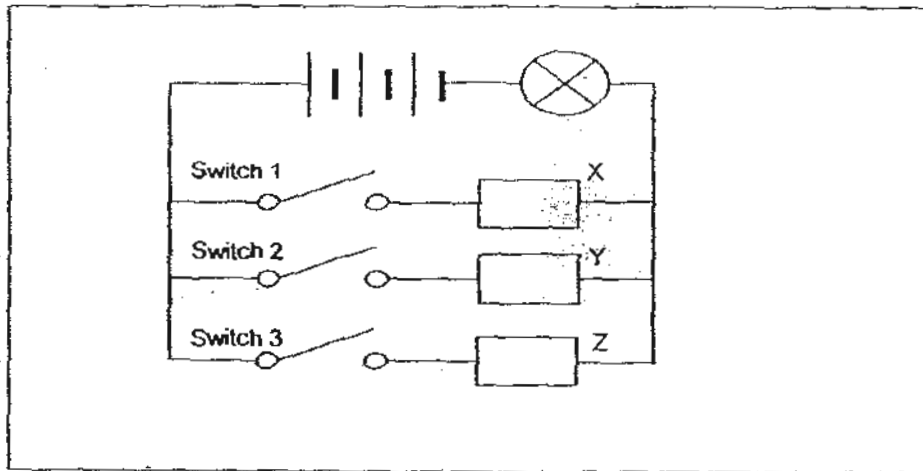

In the experiment, switch 1 was closed, but switches 2 and 3 were open. Tommy observed whether the bulb lighted up. This process was repeated with Switch 2 and Switch 3. Each time, only one switch was closed.

- a) What was the aim of the experiment? [1]

---



---

- b) Name a variable that was kept constant. [1]

---



---

- c) The table shows the outcome of the experiment.

Material	Bulb lighted up	Bulb did not light up
X	✓	
Y		✓
Z		✓

- Give an example of Material X. [1]

---

35 Timothy set up the experiment below in a dark room.

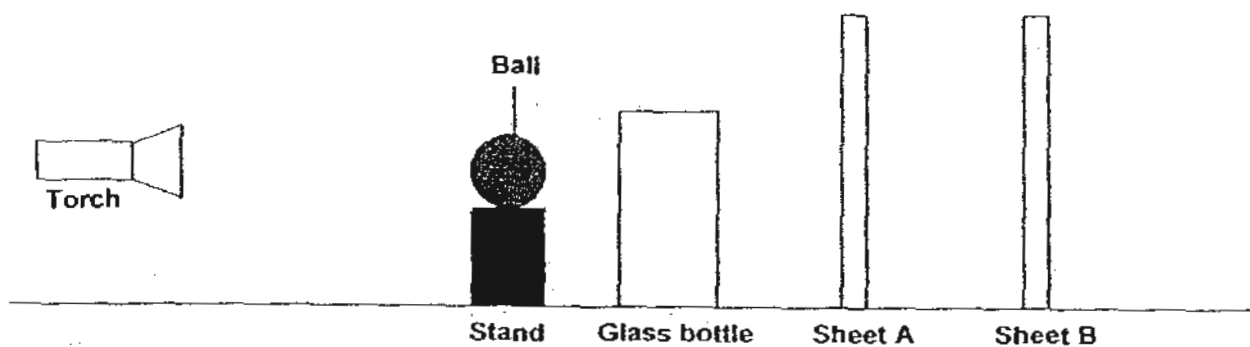

a) When Timothy turned on the torch, he observed a dark shadow on sheet A. Draw the shadow observed on sheet A. [1]

b) Based on his observations, which of the following conclusions are true, false or not possible to tell? Tick the correct answer. [1]

	Conclusion	True	False	Not possible to tell
(1)	Sheet A allows light to pass through			
(2)	Sheet B is opaque			

c) What must Timothy do to the torch to make the shadow of the ball and stand bigger? [1]

---



---

36 Leon carried out an experiment to learn more about heat.

He first recorded the temperature of the air in a bottle as shown in Set-up A. Then he placed several hot stones in the bottle. After 15 minutes, he recorded the temperature of air in the bottle as shown in Set-up B.

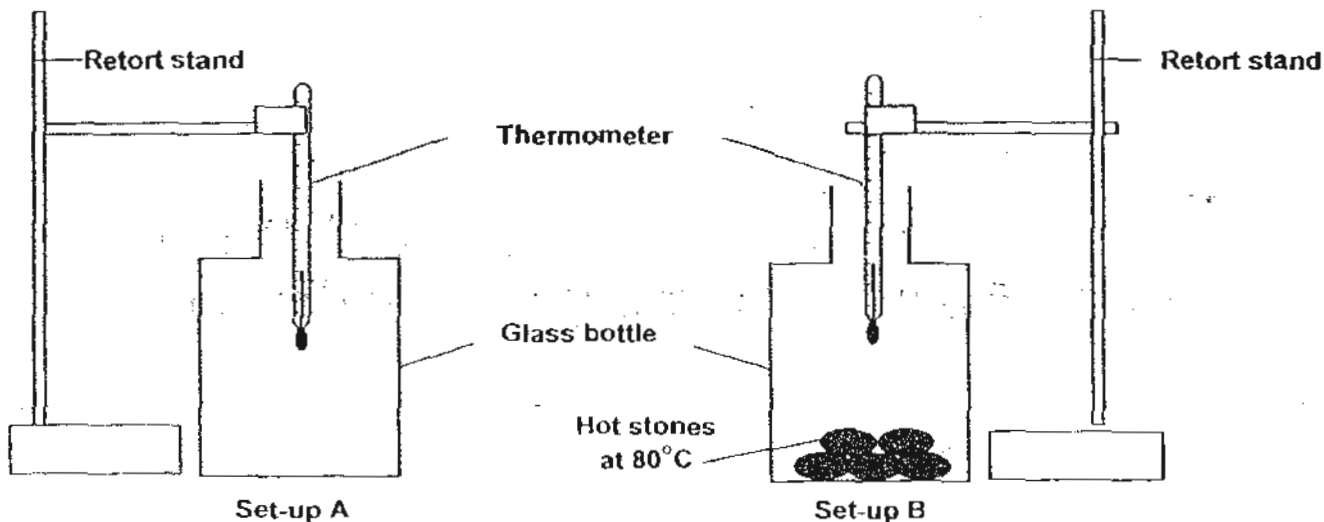

His results are shown in the table below.

Temperature of air in the bottle	
Set-up A	Set-up B
30°C	35°C

a) Explain why there was an increase in the temperature of the air in Set-up B. [1]

---

---

b) What is the purpose of Set-up A? [1]

---

---

Leon carried out the same experiment with metal bottles. The table shows the new results.

Temperature of air in the metal bottle	
Set-up A	Set-up B
29°C	33°C

- c) Explain why the temperature is lower when the metal bottles are used. [1]

---

---

- 37 Study the experiment below carefully.

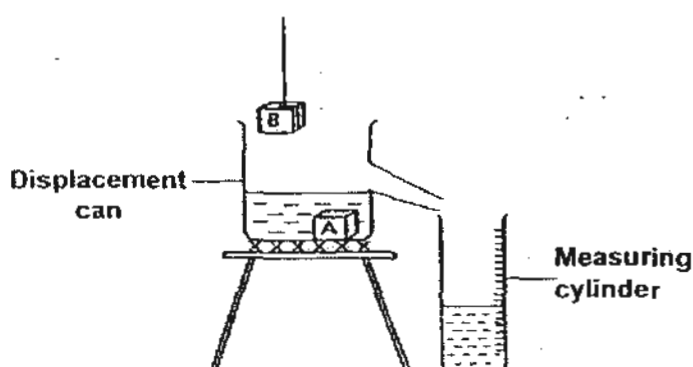

When Block A is lowered into the displacement can,  $30\text{cm}^3$  of water flows from the can into the measuring cylinder. When Block B is lowered into the can, with Block A still inside the can, the volume of water in the measuring cylinder is now  $100\text{cm}^3$ .

- a) What is the volume of Block B? [1]

---

- b) Based on the result of the experiment, what conclusion can you draw about solids? [1]

---

---

38 Jonathan was given a steel nail, some copper wires, one battery and some paperclips as shown below.



Steel nail

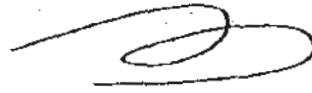

Copper wires

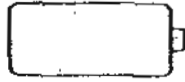

Battery

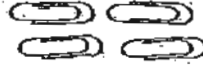

Paperclips

a) Using the items given, draw a diagram to show how he can use the steel nail as a magnet. [2]

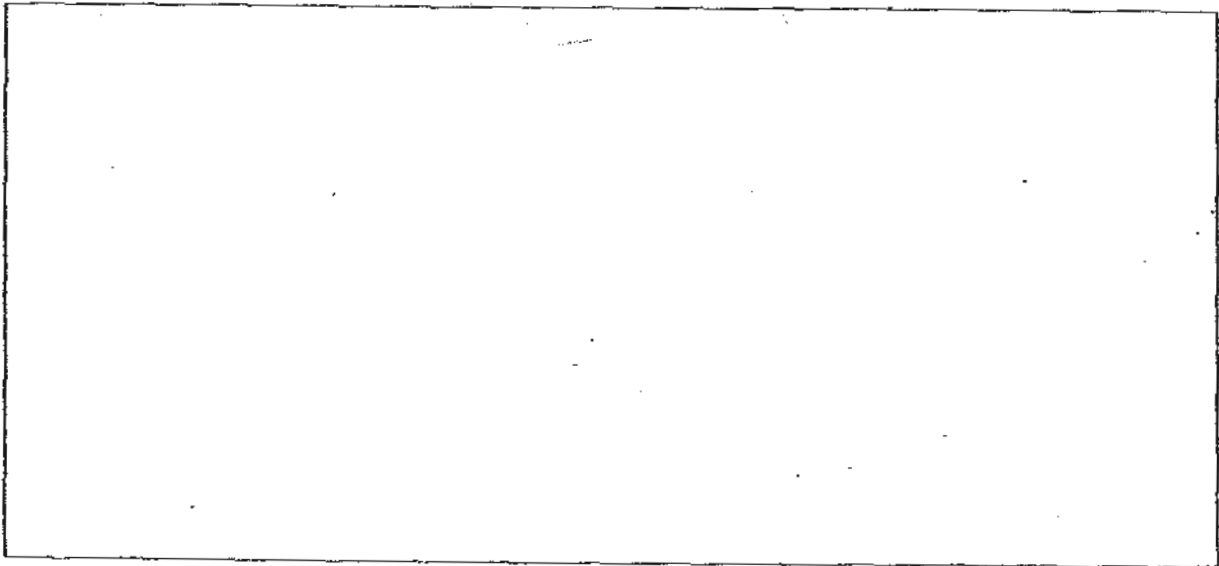

b) What can Jonathan do to make his magnet stronger? [1]

---

---

Score	
-------	--

39 The diagram below shows a separator unit being deployed in a recycling centre.

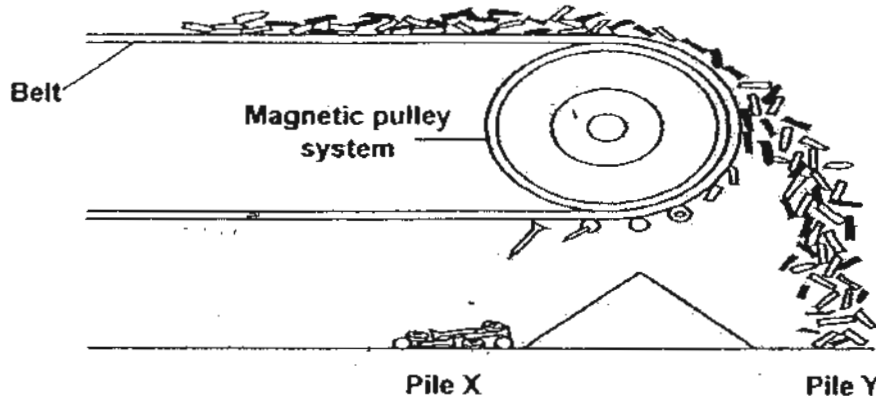

The recycled materials contain consumer waste as well as industrial waste. It includes short steel pipes, plastic bottles, soft drink cans, copper wires, iron nails and house keys.

As the magnetic pulley system rotates, it separates the waste into two different piles, X and Y.

a) Tick the items that will be found in pile Y. [1]

Items	Pile Y
short steel pipes	
plastic bottles	
soft drink cans	
copper wires	
iron nails	
house keys	

b) Explain how the separator unit works. [2]

---



---



---

----- THE END -----



36)a)The heat travels from the hot stone to the air.

b)It was used a control to ensure that the only change in temperature is due to the stones.

c)Metal is a good conductor of heat thus it lost heat to the surrounding air faster.

37)a)70cm<sup>3</sup>.

b)Solids occupy space.

38)a)

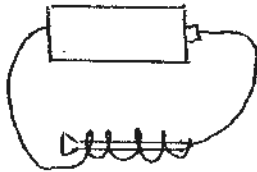

b)Increase the amount batteries.

39)a)Plastic bottles

Soft drink cans

House keys

b)As the belt moved, the magnetic objects get attracted to the magnetic pulley system and fall into a pile while the non-magnetic objects fell into a separate pile.