

METHODIST GIRLS' SCHOOL

Founded in 1887



PRIMARY 5 MID-YEAR EXAMINATION 2010 SCIENCE

BOOKLET A

Total Time : 1 hour 45 minutes

INSTRUCTIONS TO CANDIDATES

Do not open the booklet until you are told to do so.
Follow all instructions carefully.
Answer all questions.

Name: _____ ()

Class: Primary 5. _____

Date: 10 May 2010

5043

This booklet consists of 18 printed pages.

SECTION A (30 X 2 MARKS)

For each question, four options 1, 2, 3 and 4 are given. One of them is the correct answer. Make your choice (1, 2, 3 or 4). Shade the correct oval (1, 2, 3 or 4) on the Optical Answer Sheet.

1. The flowchart below shows the characteristics of some plants.

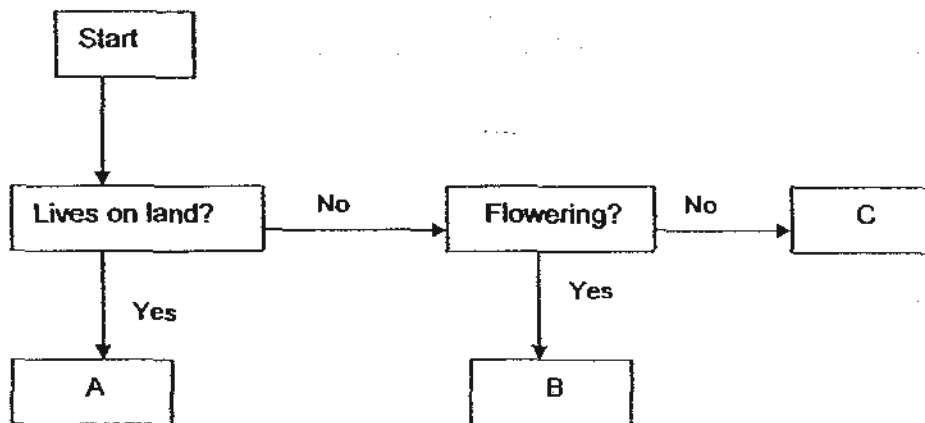

Which one of the following best represents A, B and C above?

	A	B	C
(1)	Moss	Hydrilla	Lotus
(2)	Moss	Hydrilla	Bamboo
(3)	Grass	Water Lily	Hydrilla
(4)	Mushroom	Moss	Bamboo

2. A pupil compares the life cycle of a butterfly with a cockroach's.

	Characteristics	Butterfly	Cockroach
A	Has a four-stage life cycle.	Yes	Yes
B	Has a pair of wings in larva stage.	No	Yes
C	Resembles its parents when young.	No	Yes
D	Undergoes moulting when young.	No	Yes

Which of the following comparisons above are incorrect?

- ~~(1)~~ A and B only
- ~~(2)~~ A and D only
- ~~(3)~~ A, B and D only
- ~~(4)~~ B, C and D only

3. Study the classification table below.

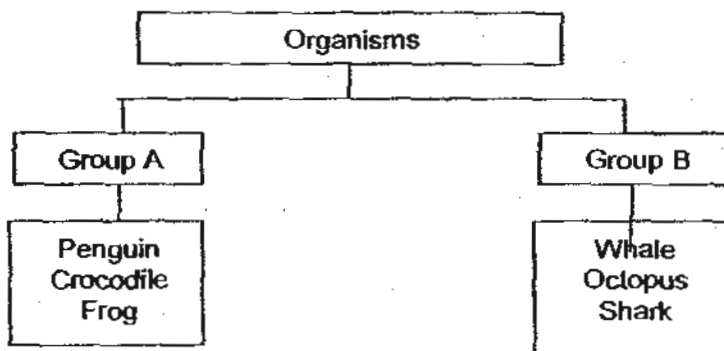

How are the above organisms grouped?

	Group A	Group B
(1)	Give birth to young alive	Lay eggs
(2)	Move on land and in water	Move in water only
(3)	Move on land only	Move in water only
(4)	No fur	Has fur

4. Which of the following shows the correct order of stages in the life cycle of an insect?

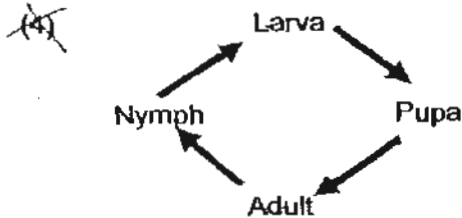
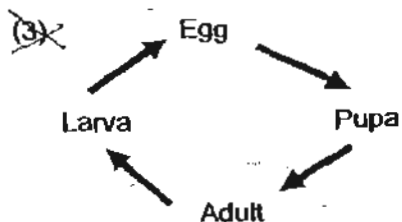
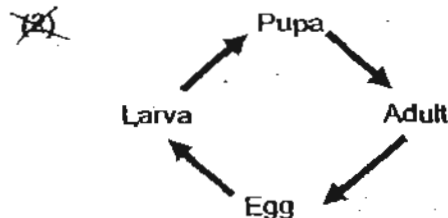
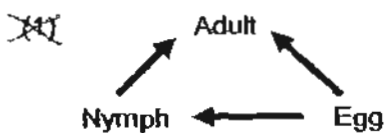

5. The diagram below shows the cross-section of a stem.

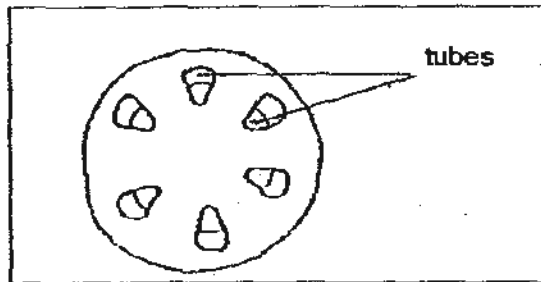

What is the importance of the tubes?

- They store food made by the leaves.
 - They allow air to move in and out of the stem.
 - They transport water and oxygen to all parts of the plant.
 - They transport water, minerals and glucose to all parts of the plant
6. Lisa set up an experiment to investigate if water is necessary for the germination of seeds.

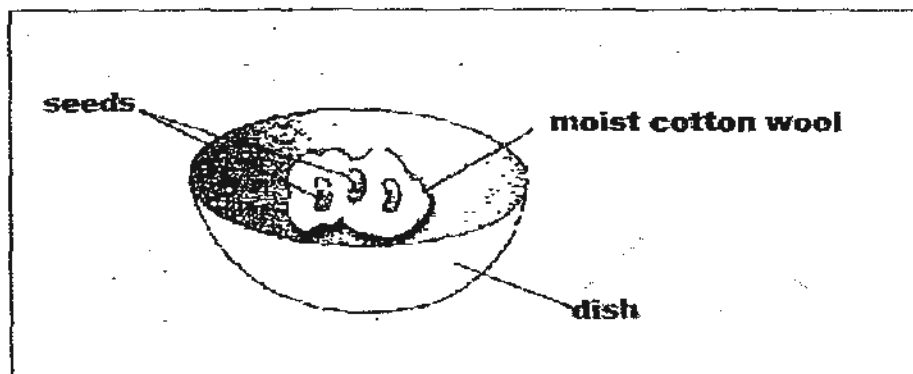

Which of the following diagram should she use as a control for her experiment?

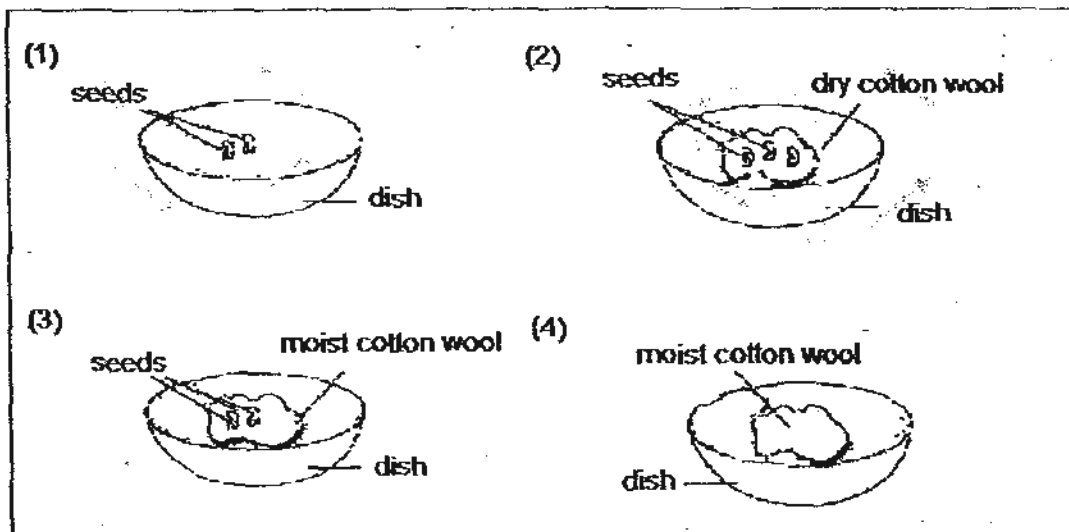

7. Sue was learning about cells in the human body. She was given slides of the four different types of cells as shown in the diagram below.

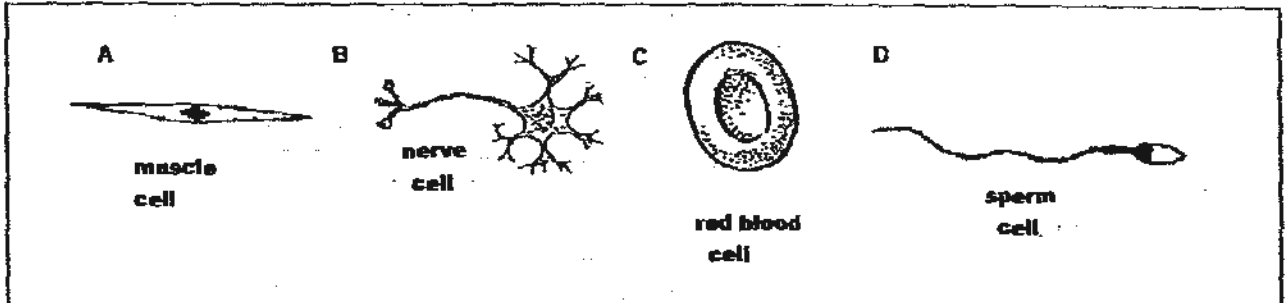

Which of the following statements explains why cells come in different shapes?

- (1) Cells have different sizes.
- (2) Cells have different functions.
- (3) Cells have different life spans.
- (4) Cells reproduce using different methods.

8. Humans have a respiratory system that helps us to breathe.

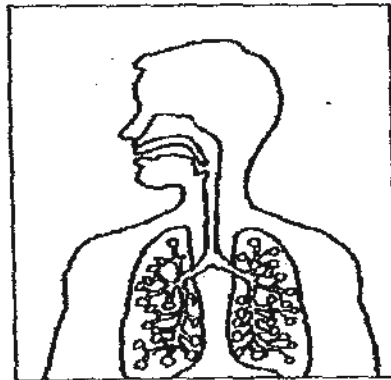

The air that we breathe in contains less _____ than air that we breathe out.

- A : oxygen
- B : nitrogen
- C : carbon dioxide
- D : water vapour

- (1) A and B only
- (2) C and D only
- (3) A and C only
- (4) A, B and C only

9. Which one of the following statements is wrong?

	Parts of a cell	Function
(1)	Cell membrane	It controls the movement of materials in and out of the cell.
(2)	Cytoplasm	It holds large amounts of water and waste products.
(3)	Nucleus	It controls all the activities of the cell and contains information that is passed from one generation to the next.
(4)	Cell Wall	It supports the plant cell and gives it its regular shape.

10. In what ways are the cells that make up the heart muscles and the cells that make up the leg muscles similar?

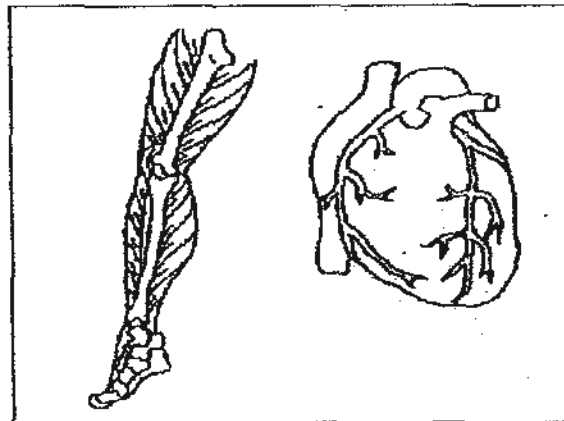

- A : They are of the same shape and size.
- B : They have the cell wall to give them shape and support
- C : They have a nucleus that contains genetic materials called genes
- D : They have the cell membrane that controls the movement of substances in and out of the cell.

- ~~A~~ A and D only
- ~~B~~ B and C only
- ~~C~~ C and D only
- ~~D~~ B, C and D only

11. The diagram below shows a plant cell.

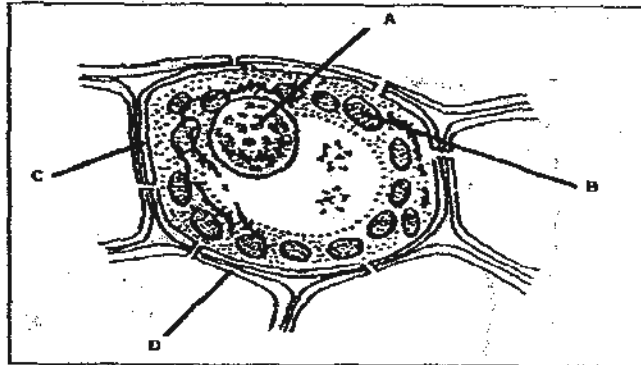

Which labelled part acts as a structural support for the cell?

- (1) A
- (2) B
- (3) C
- (4) D

12. An tank containing some aquatic plants is placed in a sunny place.

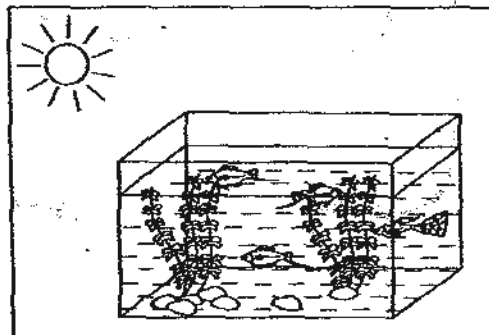

Identify the factors that will affect, directly or indirectly the amount of oxygen in the water.

- A : The intensity of the light.
- B : The amount of plants in the tank.
- C : The number of fish in the tank
- D : The material that the tank is made of.

- ~~(1)~~ A and B only
- ~~(2)~~ B and D only
- ~~(3)~~ A, B and C only
- ~~(4)~~ B, C and D only

13. The diagram below shows the exchange of oxygen and carbon dioxide in living things.

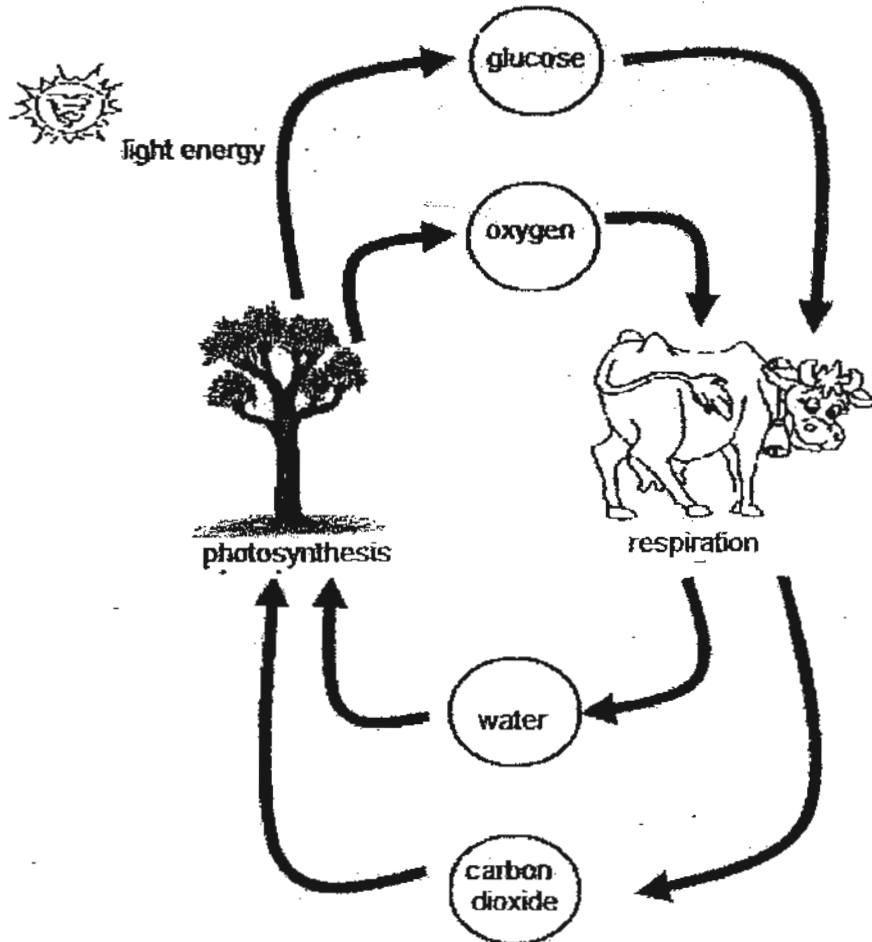

Which statements correctly interpret this diagram?

- A : Photosynthesis requires light energy.
- B : Photosynthesis produces carbon dioxide.
- C : Glucose and oxygen are necessary for respiration in animals.
- D : Glucose and carbon dioxide are produced by respiration in animals.

- ~~(1)~~ A and B only
- ~~(2)~~ A and C only
- ~~(3)~~ B and D only
- ~~(4)~~ A, C and D only

14. Harry placed some soil and some plants in a glass jar. He added some water to the jar and then sealed it with a lid. Harry observed that the plants in the jar continued to grow.

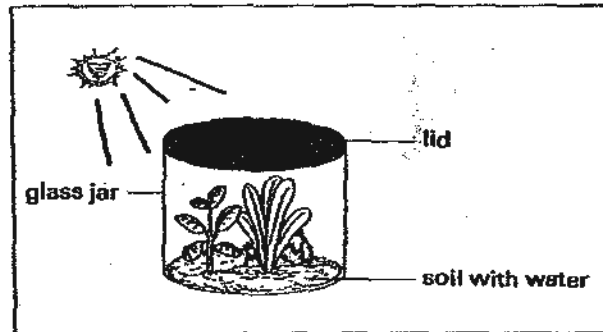

The plants in the jar were able to make its own food to survive. Where did the plant obtain carbon dioxide from?

- A : The glass jar
- B : The plant during respiration.
- C : The organisms in the soil.
- D : The plant during photosynthesis.

- ~~(11)~~ A and B only
- ~~(12)~~ B and C only
- ~~(13)~~ C and D only
- ~~(14)~~ B, C and D only

15. The diagram below shows the control used in an experiment to be carried out in a sunny place.

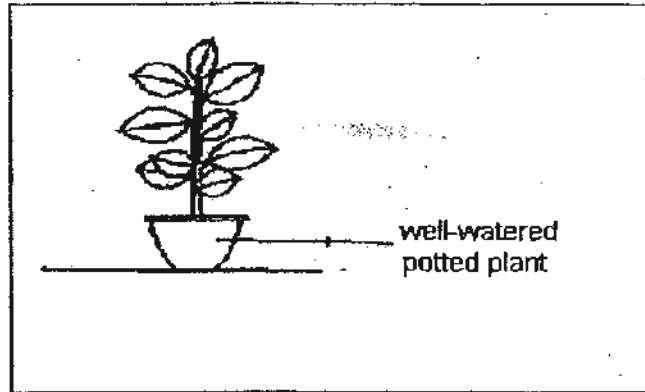

Which of the set-ups below can be used with the above control to show that light is necessary for photosynthesis to take place?

<p>(1)</p> <p>leaf covered with black paper</p> <p>well-watered potted plant</p>	<p>(3)</p> <p>stem and branches coated with petroleum jelly</p>
<p>(2)</p> <p>underside of leaves coated with petroleum jelly</p> <p>well-watered potted plant</p> <p>beaker of lime water</p>	<p>(4)</p> <p>layer of oil</p> <p>beaker of water</p>

16. Z is an object that comes from plants and is opaque. Which of the following is Z?

- (1) Silk scarf
- (2) Wool sweater
- (3) Exercise book
- (4) Tracing paper

17. The table below shows the properties of X, Y and Z.

	Has definite volume	Has definite shape
X	Yes	No
Y	No	No
Z	Yes	Yes

Which one of the following combinations best describes X, Y and Z?

	X	Y	Z
(1)	oxygen	bench	sponge
(2)	alcohol	water vapour	plasticine
(3)	steam	nitrogen	coffee
(4)	orange juice	nail	carbon dioxide

18. Jolene was trying to make a temporary magnet with a steel nail. She moved a magnet up and down along the nail as shown in the diagram. When she placed the steel nail near some pins, nothing happens. What could be the reason?

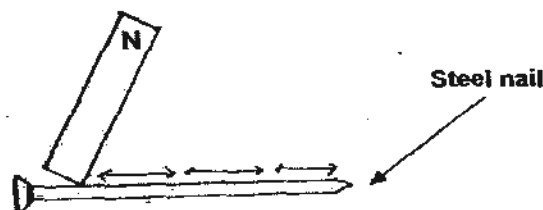

- (1) She should use a bigger magnet.
- (2) She used the wrong pole of the magnet.
- (3) She should use a copper nail instead of a steel nail.
- (4) The steel nail must be stroked in the same direction.

19. The diagrams below show 4 circuits with different connections. Which one of the bells will most likely ring the loudest?

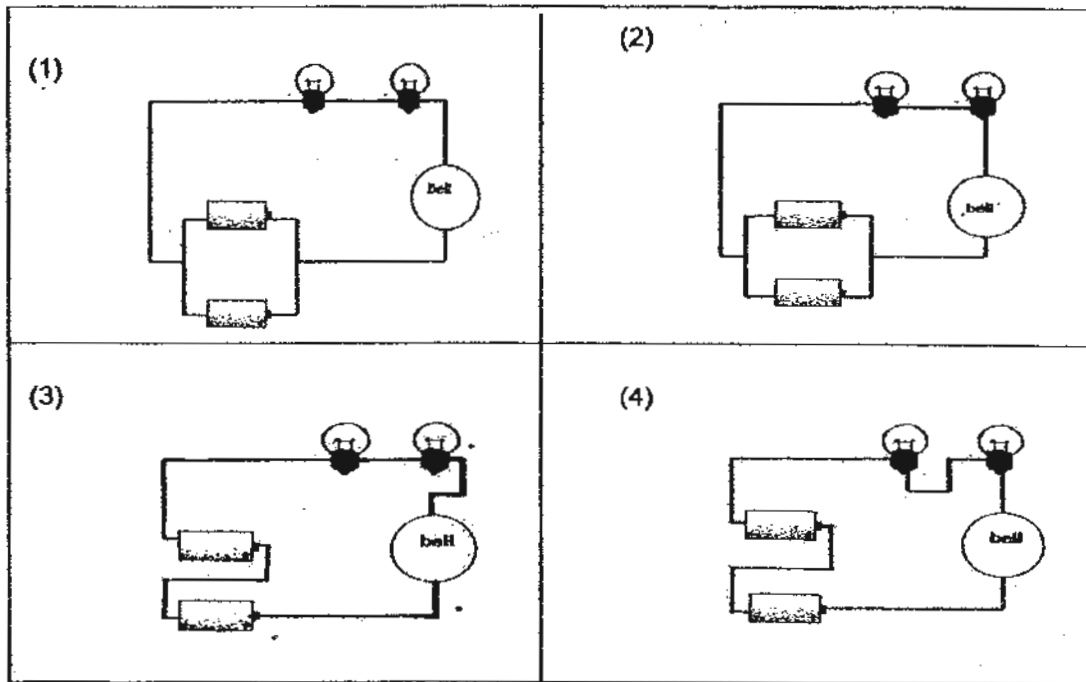

20. Siti wanted to test the strength of five magnets, P, Q, R, S and T by placing each of them near a pile of paper clips. She recorded her observations in the table below.

Magnet	Distance between each magnet and paper clips (cm)	Number of paper clips attracted
P	4	11
Q	3	6
R	2	8
S	4	8
T	3	11

What can Siti conclude based on her observations above?

- (1) Magnet R is the weakest.
- (2) Magnet S is weaker than magnet R.
- (3) Magnet Q is stronger than magnet S.
- (4) Magnet P is stronger than magnet S.

21. The following diagram shows three shadows of three similar sticks, E, F and G, placed at different positions between the light source and the screen.

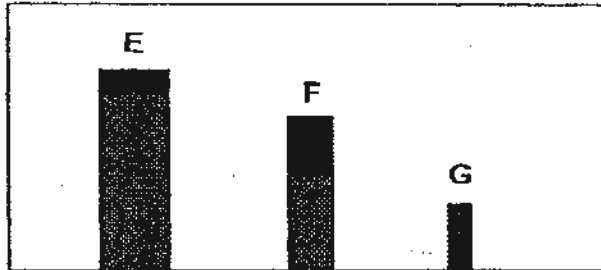

Which one of the following shows the correct positions of the sticks?

<p>(1)</p>	<p>(2)</p>
<p>(3)</p>	<p>(4)</p>

22. The diagram below shows an enclosed glass tank. The temperature of the warm air inside the glass tank is 50°C while the temperature of the cold air surrounding the tank is 10°C .

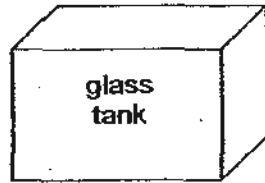

Which of the following can be observed after a while?

- (1) Water droplets will be seen on the inside of the tank.
 - (2) Water droplets will be seen on neither side of the tank.
 - (3) Water droplets will be seen on the outside of the tank.
 - (4) Water droplets will be seen on both inside and outside of the tank.
23. Study the table below.

Connection	Does the bulb light up?
A to B	Yes
A to C	No
B to D	Yes
C to D	No
A to E	Yes

Which circuit card below shows the correct connection as indicated by the table above?

<p>(1)</p>	<p>(2)</p>
<p>(3)</p>	<p>(4)</p>

24. Two solid blocks, P and Q, of different sizes, are made from the same material.

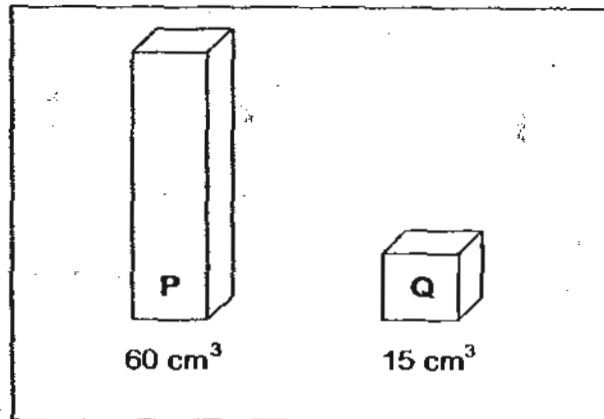

They were dropped into a tank of water.

Block P sank to position A as shown in the diagram below.

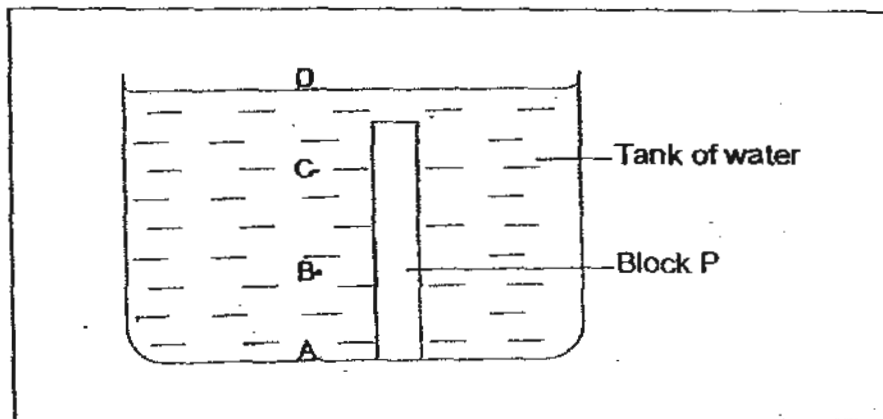

In which position, A, B, C or D, would the lower part of block Q be after it was dropped into the tank?

- (1) A
- (2) B
- (3) C
- (4) D

25. Two similar beakers of ice cubes are placed on a steel and a wooden surface as shown below.

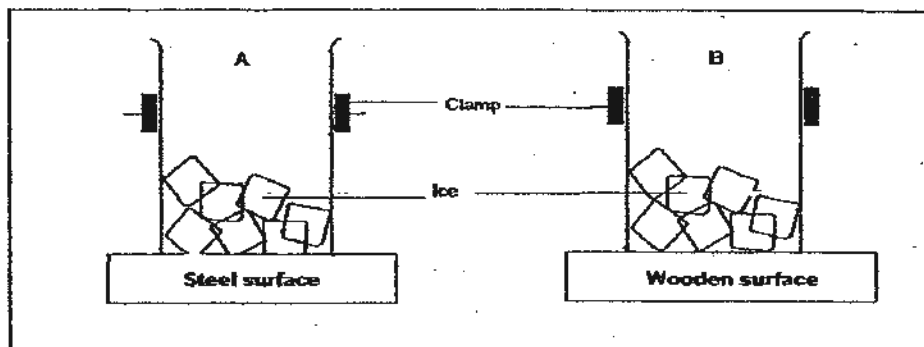

Four students made the following comments about the set-up.

- Andy: The wooden surface feels warmer than the steel one as it gains heat more quickly from the surrounding air.
- Benny: The steel surface feels cooler than the wooden one as it loses heat to the beaker of ice more quickly.
- Carol: The ice cubes in beaker B will melt faster than those in beaker A.
- Dan: Heat travels from the steel surface to the ice in set-up A.

Who were correct?

- ~~(1)~~ Benny and Dan
~~(2)~~ Andy and Carol
~~(3)~~ Andy Carol and Dan
~~(4)~~ Benny, Carol and Dan

26. The table below shows the state of four substances P, Q, R and S, at different temperatures.

Substance	State of substance at		
	10 °C	40 °C	70 °C
P	Liquid	Liquid	Liquid
Q	Solid	Liquid	Liquid
R	Solid	Solid	Liquid
S	Solid	Solid	Solid

Which one of the following statements is definitely correct based on the table above?

- (1) Substance P has the lowest boiling point.
 (2) The melting point of Substance Q is 40 °C.
 (3) The boiling point of Substance R is 70 °C.
 (4) Substance S has the highest freezing point.

27. The following chart gives information on two materials, X and Y, based on two uses.

A tick (✓) indicates that the material can be used for that purpose.

Uses	Material X	Material Y
Can be used to make a cooking pot	✓	✓
Can be used to make compass needle		✓

From the information above, which one of the following statements about Materials X and Y is cannot be true?

- (1) Both are opaque.
- (2) Both are magnetic.
- (3) Both are electrical conductors.
- (4) Both are good conductors of heat.

28. Joe broke a bar magnet into three pieces, X, Y and Z, as shown below.





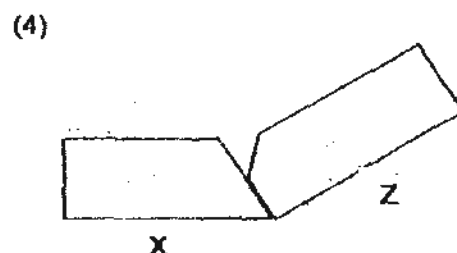
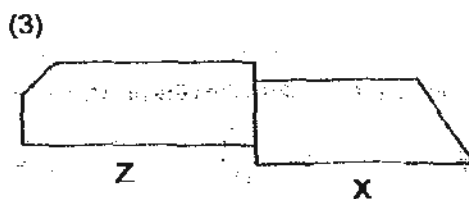
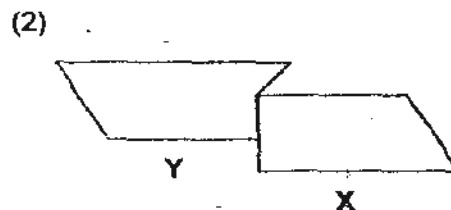
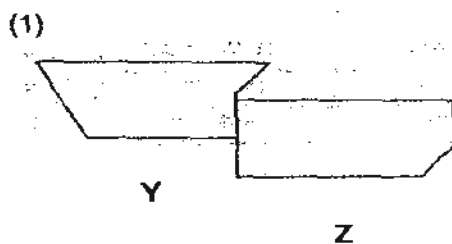

Which one of the following is not possible when two broken pieces of magnet are put together?



29. Four different metals, A, B, C and D were used to make 3 sets of rings as shown in the diagrams below. All the sets of rings were similar except for the materials used.



Legend:			
			
Metal A	Metal B	Metal C	Metal D

At 30°C, all the inner rings of each set could just fit into the outer ring and still be pulled out with some effort. The sets of rings were heated evenly from 30°C to 60°C and the observations were recorded in the table below.

At 60 °C		
Set 1	Set 2	Set 3
Ring B fell out of ring A easily	Ring C could not be pulled out even with great effort	Ring C could barely fit into the outer ring and needed a little more effort than usual to pull it out.

Based on the observations, arrange the Metals A, B, C and D according to the one that expands the least to the one that expands the most when heated.

- (1) A, B, C, D
- (2) A, C, B, D
- (3) D, B, C, A
- (4) D, C, B, A

30. Mr Thomas set up the following experiment as shown. He wanted his students to observe the water in the beaker in order to draw a conclusion about Object X.

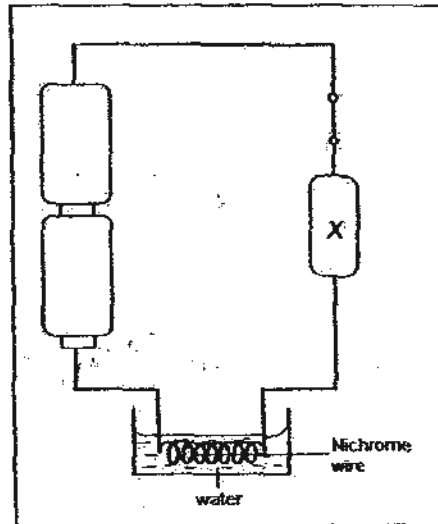

After some time, the class noticed small bubbles near the nichrome wire. The following are conclusions drawn by four students about Object X.

- Kitty: Object X is warm.
Bee Ting: Object X is made of iron.
Fatimah: Object X is an insulator of electricity.
John: Object X is a conductor of electricity.

Which student(s) is/are correct?

- (1) Fatimah only
- (2) Kitty and John
- (3) Fatimah and Bee Ting
- (4) Kitty, Fatimah and John

- End of Booklet A -

METHODIST GIRLS' SCHOOL

Founded in 1887



PRIMARY 5 MID-YEAR EXAMINATION 2010 SCIENCE BOOKLET B1

Total Time : 1 hour 45 minutes

INSTRUCTIONS TO CANDIDATES

Do not open the booklet until you are told to do so.
Follow all instructions carefully.
Answer all questions.

Name: _____ ()

Class: Primary 5. _____

Date: 10 May 2010

Booklet A	/ 60
Booklet B1	/ 20
Booklet B2	/ 20
TOTAL	/ 100

This booklet consists of 5 printed pages.

Section B1 : 20 marks

Write your answers for each question in the blanks provided.

31. Study the flow chart below.

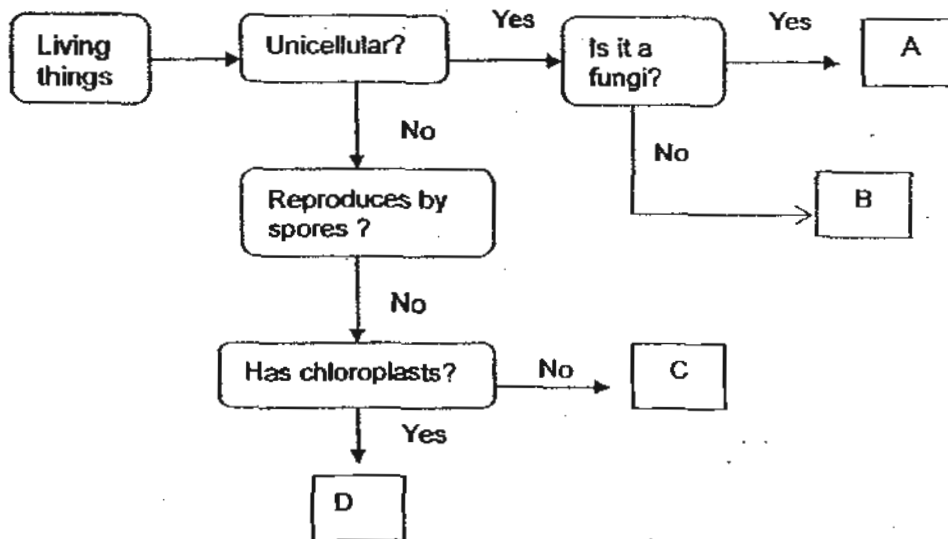

Give an example for A, B, C and D. (2m)

A: _____

B: _____

C: _____

D: _____

32. A group of scientists made a study into the survival rate of mosquito eggs in different types of water. The table below shows the results.

Types of water	Number of larvae hatching from the eggs	Number of pupae formed	Number of adults formed
Mineral	35	2	0
Tap	38	3	0
Reservoir	36	32	30
Drain	38	35	34
Pond	38	35	35

- (a) If the mosquitoes were allowed to lay their eggs naturally, where would be the best breeding area? (1m)
-
- (b) Give a reason why the number of larvae hatched in mineral and tap water that form into pupae is less as compared to those in the drain and the pond? (1m)
-
- (c) In order to survive in the water, the scientists observe that the mosquito larvae and pupae position themselves near the water surface. Give a reason for their observation. (1m)
-

33. Gaseous exchange takes place in plants. The diagram below shows the structures on the leaves which facilitate gaseous exchange.

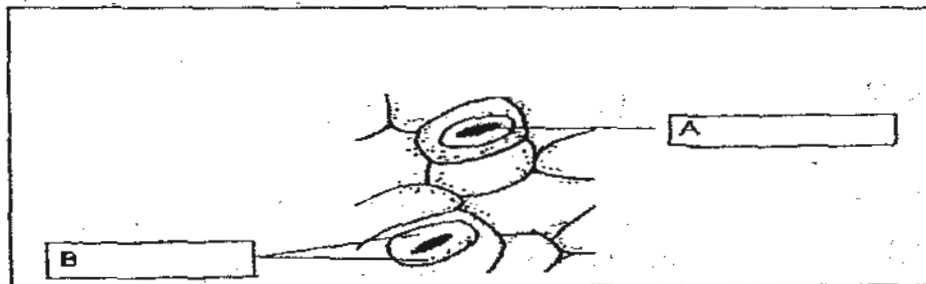

- (a) Label the parts A and B as indicated. (1m)
- (b) Name two external factors that would cause the size of the part labelled A to change. (2m)
-

34. Sam was able to run fastest during the first round around the 400-m track. During the 3rd and 4th rounds, he was taking short and quick breaths and his heart began to beat faster.

(a) Give one reason why Sam was taking short and quick breaths during the 3rd and 4th round? (1m)

(b) Name the body system/s that is / are working together to enable Sam to carry out the activity? (1m)

35. The diagram below shows a bacterial cell and an animal cell.

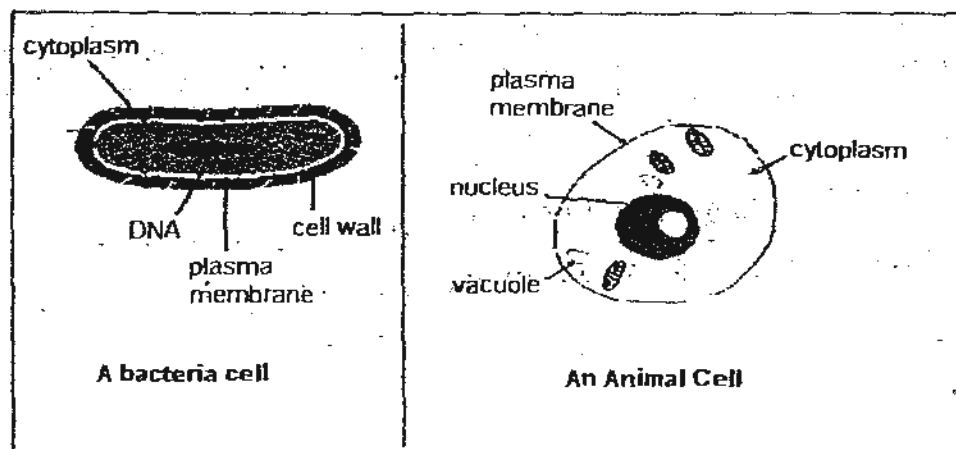

(a) Give one difference between the bacteria cell and the animal cell. (1m)

(b) Some bacteria are useful and some are harmful if they enter your body. List two ways in which bacteria can enter your body. (2m)

(c) Our human body has natural immunity to fight the bacteria. Which type of cell in our body fights diseases? (1m)

36. The diagram below shows how a cell divides to form new cells.

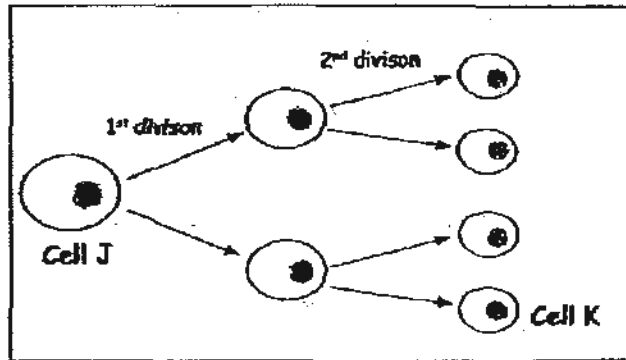

(a) Name the process that the cell is going through? (1m)

(b) How many cells would there be after the fifth division? (1m)

(c) Cell K undergoes another cell division as shown below.

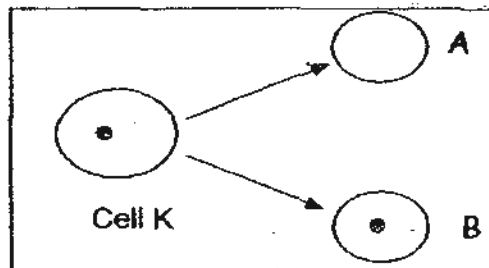

Which cell will not be able to develop further or reproduce and why? (1m)

37. Angela set up an experiment to study how temperature affects the germination of seeds. She uses three similar sized dishes, similar moist paper towels and 40 mustard seeds. She placed the three dishes in three different locations and watered them regularly.

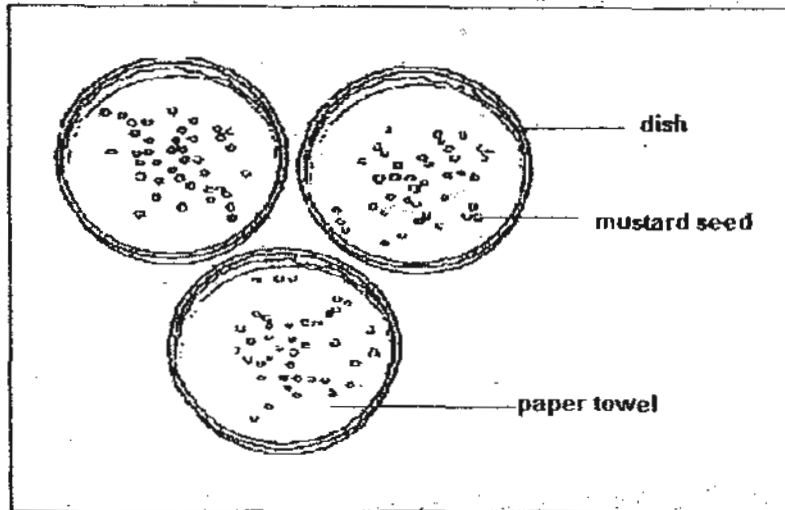

- (c) Name 2 other variables that she must keep the same to ensure that her experiment is fair. (2m)
-

- (b) The table below shows the results of Angela's experiment.

Location	Temperature of location	Number of germinated seeds		
		Day 1	Day 2	Day 3
Inside the refrigerator	3°C	0	0	0
By the window sill	18°C	0	10	20
Inside the cupboard	30°C	0	22	35

What conclusion can Angela draw from the results of her experiment? (1m)

END OF BOOKLET B1

METHODIST GIRLS' SCHOOL

Founded in 1887



PRIMARY 5 MID-YEAR EXAMINATION 2010 SCIENCE BOOKLET B2

Total Time : 1 hour 45 minutes

INSTRUCTIONS TO CANDIDATES

Do not open the booklet until you are told to do so.
Follow all instructions carefully.
Answer all questions.

Name: _____ ()

Class: Primary 5. _____

Date: 10 May 2010

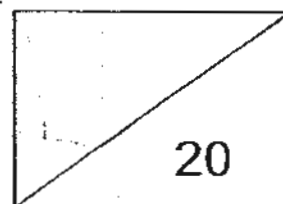

This booklet consists of 8 printed pages.

Section B2: 20 marks

Read the questions carefully and write your answers in the space provided.

38. The table below shows the melting points of some metals.
The cost required to melt a metal is lower when it has a lower melting point.

Metal	Melting Point ($^{\circ}\text{C}$)
Copper	2550
Tin	2450
Gold	2850
Aluminium	2450
Silver	2350
Iron	2550

- (a) From the table above determine the metal that has the highest and lowest melting point. (1m)

Highest melting point: _____

Lowest melting point: _____

- (b) A factory wants to use either aluminium or iron to make cans. Based on the information above, which material (iron or aluminium) do you think the factory should use? Explain your answer. (2m)

39. Mr Lee conducted an experiment to measure the amount of light that can pass through six different materials. He made use of a datalogger and recorded his results in the graph below.

Amount of light that passed through the material

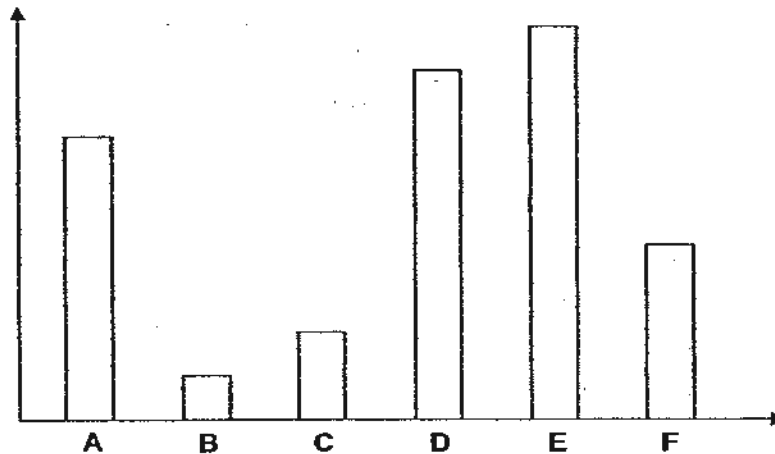

Answer the following questions based on the results given in the bar graph above.

Read the statements and tick (✓) in the appropriate boxes below.

(3m)

Statements	True	Not possible to tell	False
Material E is opaque.			
Material C is a mirror.			
Material F is able to partially block light.			
Material B is darker in colour than Material C.			
Material F has a lighter shadow than Material E			
Material D allows more light to pass through than Material A.			

40. Raine prepared a circuit tester as shown below.

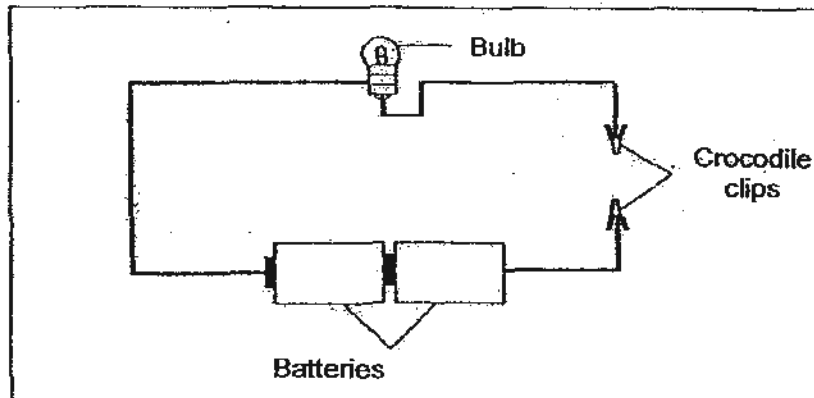

She wanted to test if some materials were conductors of electricity. She attached these materials to the crocodile clips one at a time and recorded the results in the table below.

Material	Did the bulb light up?
A	Yes
B	No
C	Yes
D	No

(a) Use the information from the table to complete the classification chart below. Write the sub-headings in boxes (i) and (ii) and the letters A, B, C and D in boxes (iii) and (iv). (2m)

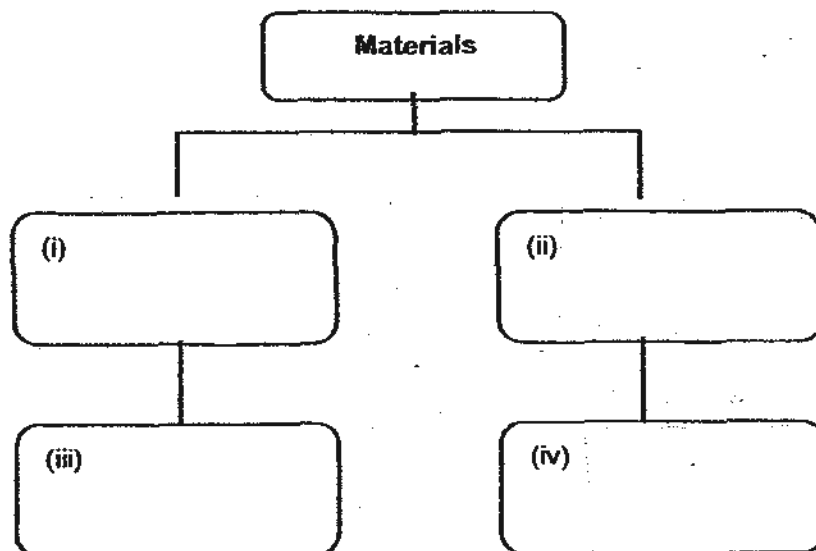

- (b) Raine set up another circuit as shown below using 2 bulbs, L1 and L2, and 3 switches, S1, S2 and S3.

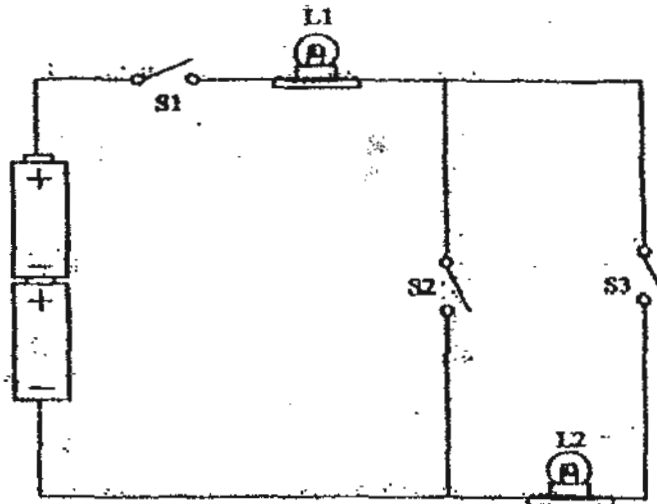

She wanted to find out which of the bulbs, L1 and L2, would light up when the switches were closed. She recorded some of the data she collected in the table shown. Fill in the empty boxes to complete the table. (2m)

Switches			Did the bulb light up?	
S1	S2	S3	L1	L2
	closed	closed	no	no
closed	open		yes	yes
open	open	closed		no
closed	closed	open	yes	

41. Shuli had a container with a capacity of 100 cm^3 . She fitted a pump on the container. Each time she pressed the pump, 100 cm^3 of air would enter the container. Shuli pressed the pump 5 times.

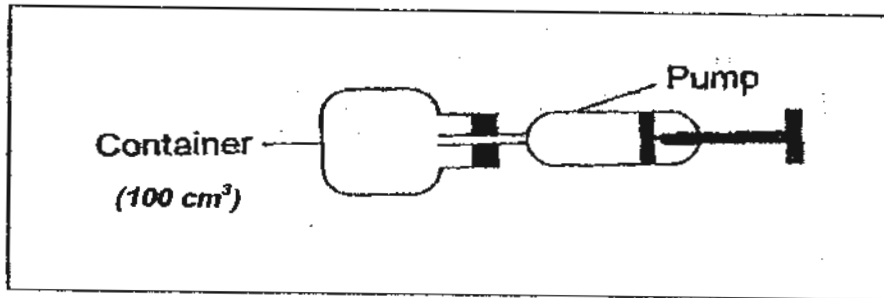

- (a) Based on the information given, draw a line graph to show the change in volume of the air in the container as ~~Kim~~ pumped air into it. (1m)

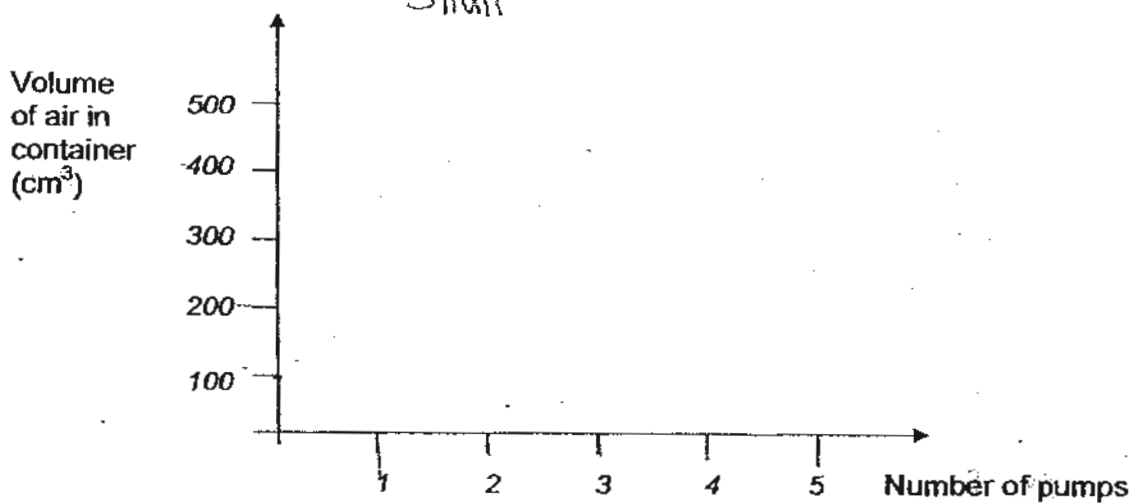

- (b) Based on your answer in (a), state 2 properties of air. (2m)

42. Miss Lim made an electromagnet out of an iron rod using the set-up as shown below.

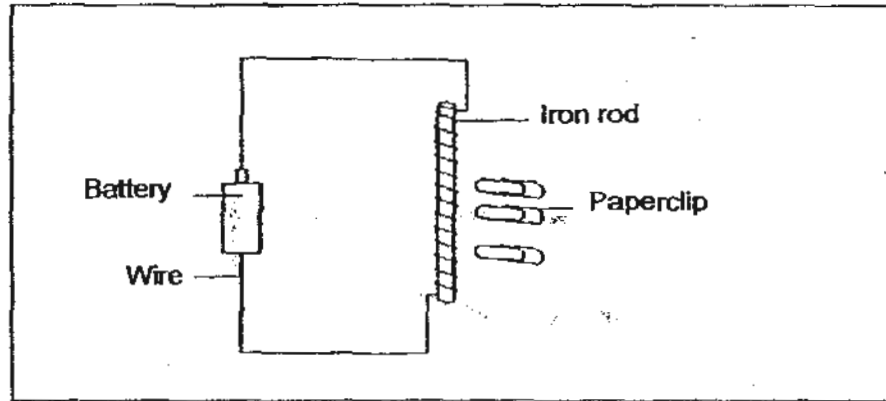

- (a) What happens to the paperclips when the electricity starts flowing through the iron rod? (1m)

- (b) Miss Lim found out that the iron rod could not attract her pair of earrings when the electricity is still flowing. Why? (1m)

- (c) Name two things Miss Lim can do to turn her iron rod into a stronger electromagnet. (1m)

43. Mr See set up an electric circuit as shown. The three objects were made of different materials. He noticed that when he turned on two switches at a time, only some bulbs lighted up.

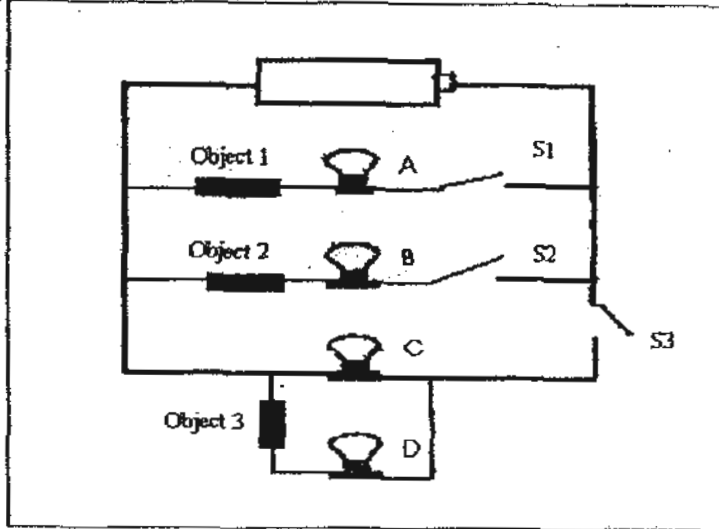

The results were recorded in the table below.

Switches turned on	Bulbs lighted up
S1, S2	A
S1, S3	A, C
S2, S3	C

- (a) From the results, identify the insulator(s) of electricity. (1m)

- (b) State an advantage of arranging the bulbs in the above manner. (1m)

44. Below is a classification table on circuits.

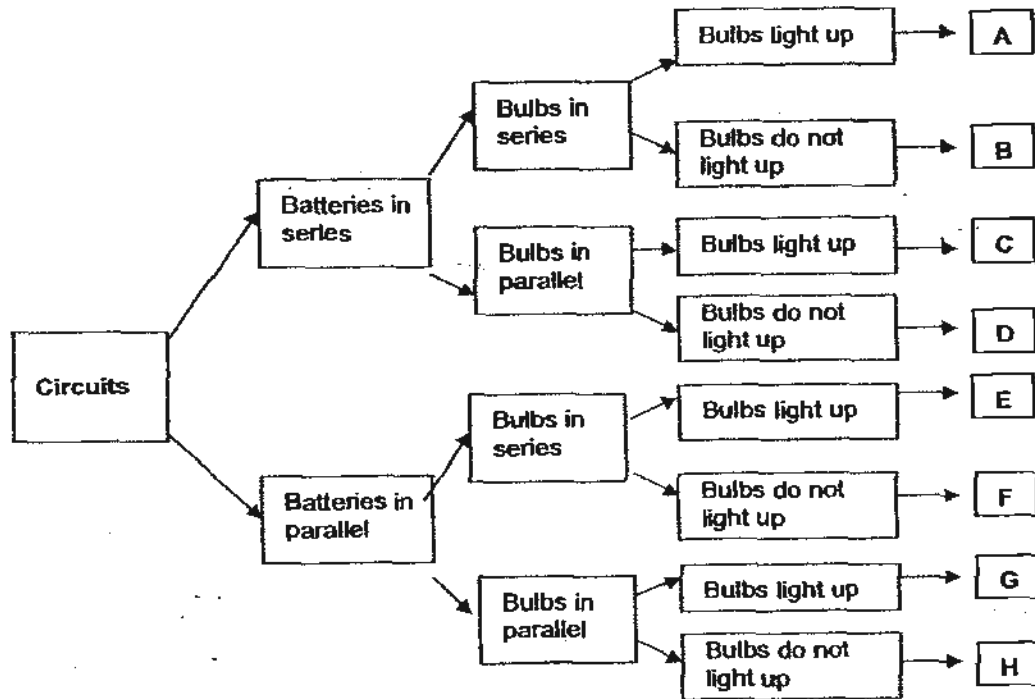

Using the key given above, match the two circuits Y and Z shown with the correct letter, A, B, C, D, E, F, G or H. Circuit X has been done for you. (2m)

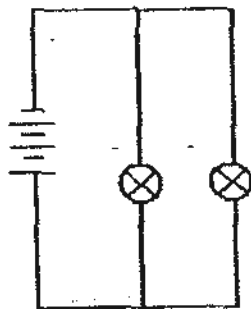

Circuit X

C

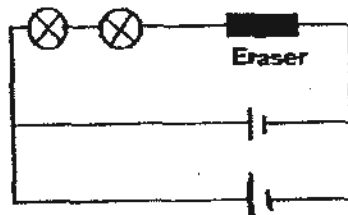

Circuit Y

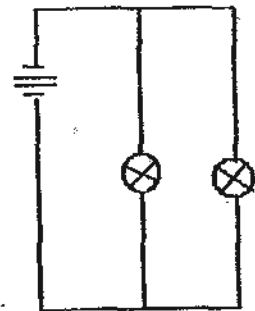

Circuit Z

End of Booklet B2

ANSWER SHEET

EXAM PAPER 2010

**SCHOOL : MGS PRIMARY
SUBJECT : PRIMARY 5 SCIENCE**

TERM : SA1

Q1	Q2	Q3	Q4	Q5	Q6	Q7	Q8	Q9	Q10	Q11	Q12	Q13	Q14	Q15	Q16	Q17
3	3	2	2	4	2	2	2	2	3	4	3	2	2	1	3	2

Q18	Q19	Q20	Q21	Q22	Q23	Q24	Q25	Q26	Q27	Q28	Q29	Q30
4	3	4	1	1	3	1	1	4	2	1	3	2

31)a) Yeast B: Amoeba C: Animals D: Plants

32)a) The best breeding area is in the pond.

b) The larvae feeds on tiny insects that live in the water, as mineral and tap water has no insects in them, the number of larvae hatched in mineral and tap water that form into pupae is less compared to those in the drain and pond.

c) All living things need oxygen. The mosquito larvae has a breathing tube slightly above the surface of the water, taking in oxygen to breathe.

33)a) A: Stoma B: Guard cells

b) Changes in temperature and the intensity of light.

34)a) Sam has to do that as more is needed to produce energy for his muscles produce due to increased respiration.

b) The respiratory system, the skeletal system, muscular system and the circulator system.

35)a) The bacteria cell has a cell wall while the animal cell does not.

b) When you eat contaminated food and when you inhale contaminated air.

c) The white blood cells.

36)a) The cell is going through cell division which is also known as mitosis.

b) (1) $1 \times 2 = 2$ (2) $2 \times 2 = 4$ (3) $4 \times 2 = 8$ (4) $8 \times 2 = 16$ (5) $16 \times 2 = 32$

There would be 32 cells.

c) Cell A. Cell A does not have a nucleus to pass the genetic information to the next cell.

37)c) The duration of experiment and the amount of water given.

d) In order for seeds to germinate, they need warmth.

38)a)Gold Silver

b)Aluminum. It requires less energy to melt it since its melting point is lower than iron so cost of production is cheaper.

39)F F T Not F T

40)a)i)conductors of electricity.

ii)Insulators of electricity

iii) A and C

iv)B and D

b)S1==open S3==closed L1==no L2==no

41)a)

Volume
of air in
container
(cm³)

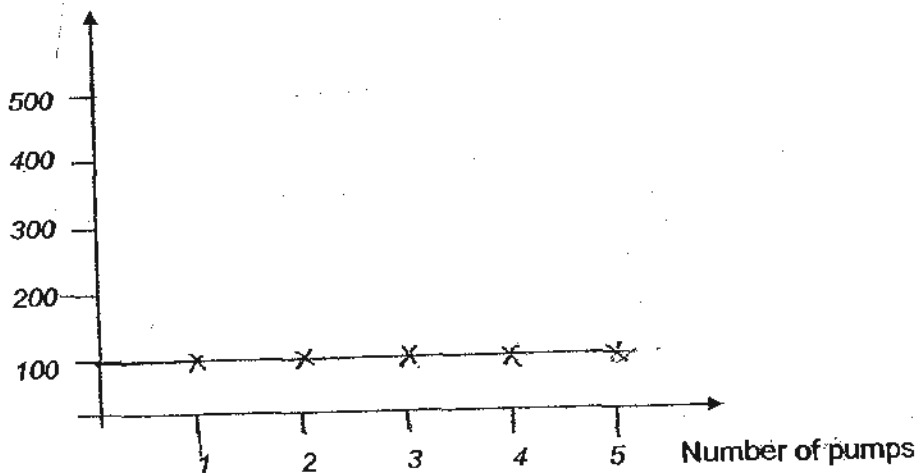

b)Air does not have a definite volume and air can be compressed.

42)a)The paperclip would get attracted to the iron rod.

b)Her ear rings may be made of a non-magnetic material.

c)She could increase the number of batteries and she could increase the number of coils around the iron rod.

43)a)Object 2 and 3.

b)If one bulb blows, the rest of the bulbs would still light up.

44)F D