



**RAFFLES GIRLS' PRIMARY SCHOOL**  
**SEMESTRAL ASSESSMENT (2)**  
**2010**

|                    |                                 |       |
|--------------------|---------------------------------|-------|
| Practical<br>10%   | <b>Your score</b><br>out of 100 |       |
| Section A<br>50%   |                                 |       |
| Section B<br>40%   |                                 |       |
|                    | Class                           | Level |
| Highest score      |                                 |       |
| Average score      |                                 |       |
| Parent's signature |                                 |       |

Name : \_\_\_\_\_ Index No: \_\_\_\_\_ Class: P 5 \_\_\_\_\_

28<sup>th</sup> October 2010

**SCIENCE**

Attn: 1 h 30 min

**SECTION A (25 X 2 marks)**

For each question from 1 to 25, four options are given.  
 One of them is the correct answer. Make your choice (1, 2, 3 or 4).  
 Shade the correct oval on the Optical Answer Sheet.

1. The table below shows some physical features of Amy and her husband, Ben.

| parent | face        | earlobes | hair  | colour of pupils |
|--------|-------------|----------|-------|------------------|
| Amy    | freckles    | detached | long  | blue             |
| Ben    | no freckles | attached | short | brown            |

Amy and Ben have four children with the following physical features:

| child | face        | earlobes | hair  | colour of pupils |
|-------|-------------|----------|-------|------------------|
| Carl  | freckles    | detached | short | brown            |
| Dawn  | no freckles | attached | long  | brown            |
| Ethan | no freckles | detached | short | blue             |
| Fanny | freckles    | attached | long  | blue             |

Based on the information above, which of the following statements is / are true?

- A Carl and Ethan are twins.
- B Ethan is the only child who inherited Ben's physical features.
- C Dawn did **NOT** inherit any of her physical features from Amy, her mother.
- D Carl and Fanny each inherited more than two physical features from their mother.

- (1) C only
- (2) A and D only
- (3) B and C only
- (4) A, B and C only

2. The diagram below shows the members of Jane's family who carry the genetic trait for disease Z.

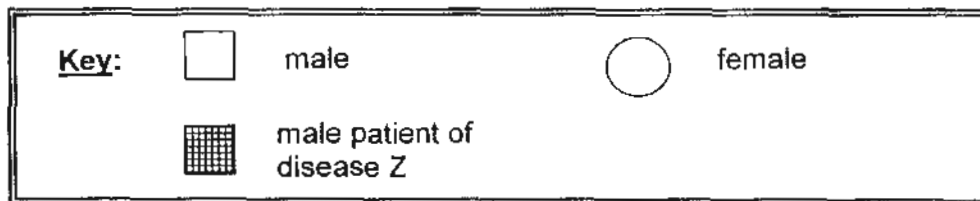
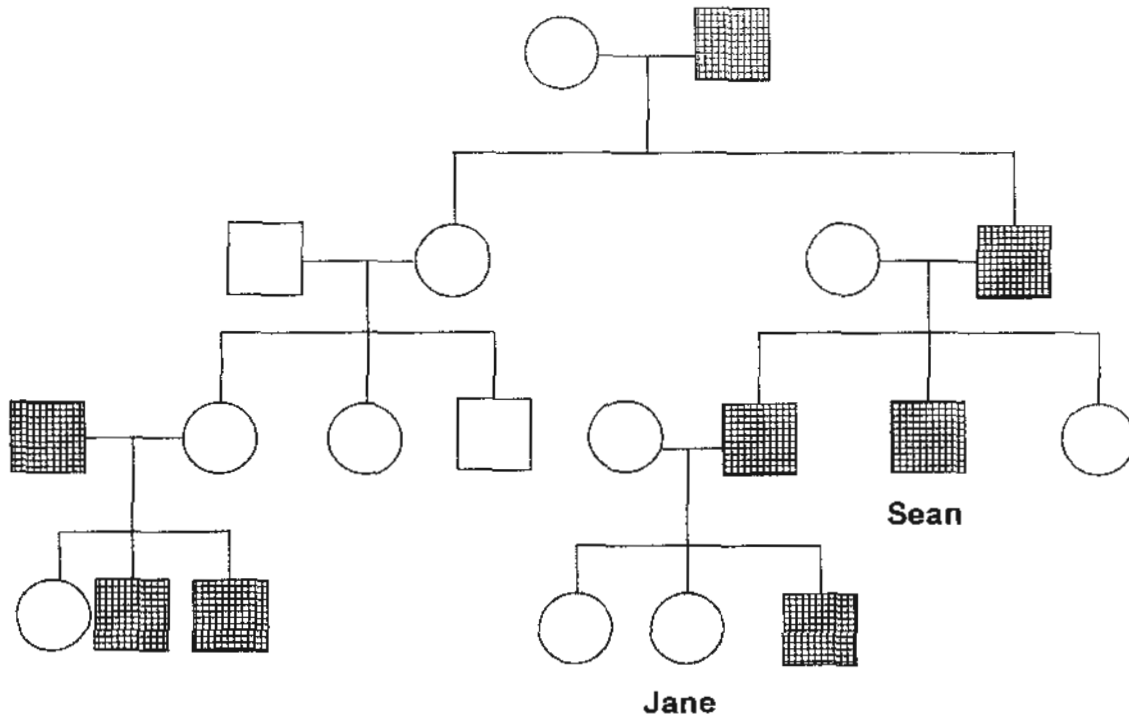

**NOTE :** The females are not carriers of disease Z.

Based on the information above, which of the following statements can be concluded?

- A Sean's son is most likely to inherit disease Z.
- B Jane's brother inherited the genes of disease Z from his mother.
- C Only Sean inherited the genes of disease Z from Jane's grandfather.

- (1) A only
- (2) C only
- (3) A and B only
- (4) B and C only

3. The diagrams below show parts of the reproductive systems of a flower and of a human.

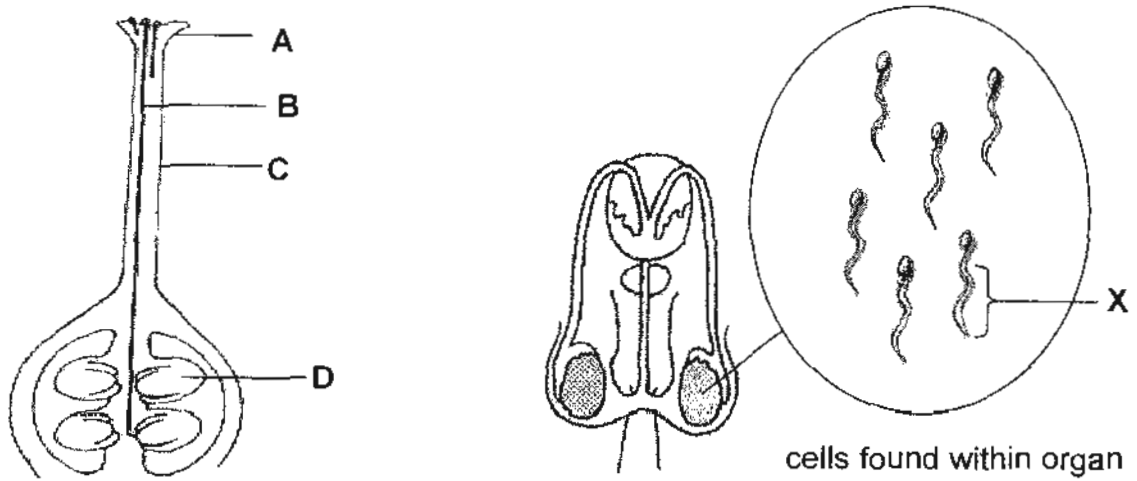

Based on the diagrams above, which part of the flower has a similar function as part X?

- |       |       |
|-------|-------|
| (1) A | (2) B |
| (3) C | (4) D |
4. Which of the following statements about sexual reproduction in **both** plants and animals are true?
- A The female sex cells are produced in the ovary.
  - B The process of pollination takes place before fertilisation.
  - C The male sex cells produced in the anthers are called spores.

- |                  |                  |
|------------------|------------------|
| (1) A only       | (2) C only       |
| (3) A and B only | (4) B and C only |

5. The picture below shows a fruit-bearing tree.

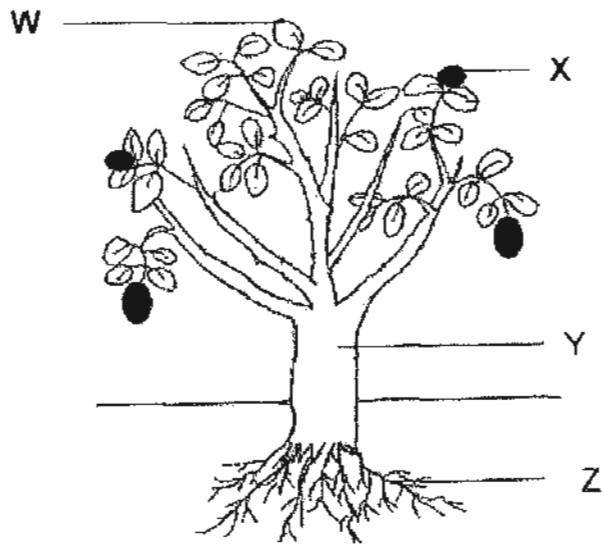

Which part of the tree produces food for itself?

- |       |       |
|-------|-------|
| (1) W | (2) X |
| (3) Y | (4) Z |

Ravi had 3 identical flasks. Each flask contained a different volume of water and liquid P to give a total volume of 120 ml. The contents of each flask were shown as follows:

| type of liquid   | increasing concentration<br>→ |     |     |
|------------------|-------------------------------|-----|-----|
|                  | F1                            | F2  | F3  |
| water (ml)       | 90                            | 60  | 30  |
| P (ml)           | 30                            | 60  | 90  |
| water and P (ml) | 120                           | 120 | 120 |

Ravi cut 3 identical cubes of substance X and put each cube in the conical flasks, F1, F2 and F3, as shown below.

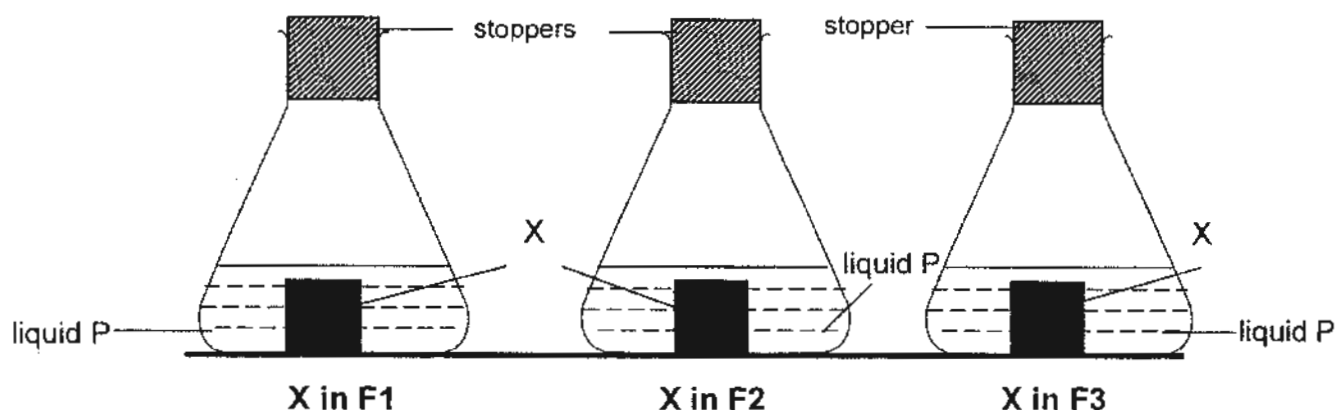

At the end of the experiment, Ravi noticed that the size of substance X in each flask was **NOT** the same.

Ravi's teacher commented that as the concentration of P increased, substance X would break down into simple substances more quickly.

Based on the information above, answer **questions 6 and 7**.

6. Which one of the following could possibly be the correct order of the time taken for a cube of substance X to break down into simple substances in each flask?

|     | → longest time taken |    |    |
|-----|----------------------|----|----|
| (1) | F1                   | F2 | F3 |
| (2) | F2                   | F1 | F3 |
| (3) | F3                   | F1 | F2 |
| (4) | F3                   | F2 | F1 |

7. Ravi was given **ANOTHER** flask, F4, which contained the same content as in F3.

Ravi poured an equal amount of liquid mixture from F4 into each petri dish, S, T and U, which contained a different shape of the same mass of substance X as shown below.

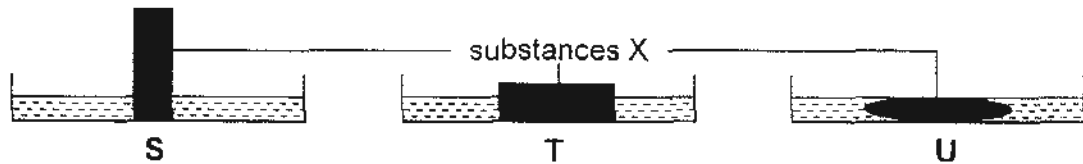

He concluded that all the 3 different shapes of the same mass of substance X took a different amount of time to break down.

Which of the following statements could possibly lead Ravi to give such a conclusion?

- A The exposed surface area of the liquid mixture in each petri dish was different.
- B The size of substance X would decrease when it was placed in the petri dish of liquid mixture.
- C The surface area of substance X in contact with the liquid mixture in each petri dish was not the same.

(1) B only

(2) A and B only

(3) A and C only

(4) B and C only

8. The diagram below shows a cell of an organism with one of its parts labelled X.

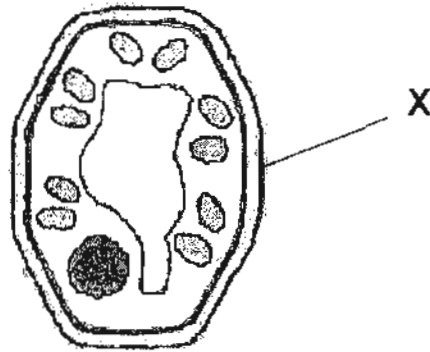

Which of the following are functions of X?

- A It gives the cell a regular shape.
- B It protects the parts within the cell.
- C It controls the movement of substances in and out of the cell.

- (1) A and B only
- (2) A and C only
- (3) B and C only
- (4) A, B and C

9. Mr Tan, David and Mary used the following apparatus to find out whose lungs can hold the most amount of air.

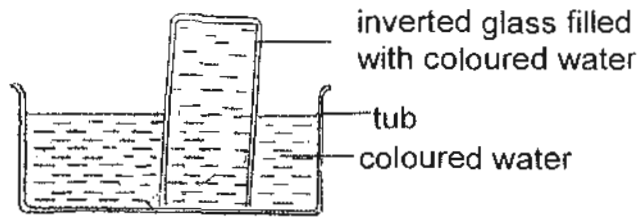

The diagrams below show the results of their experiments.

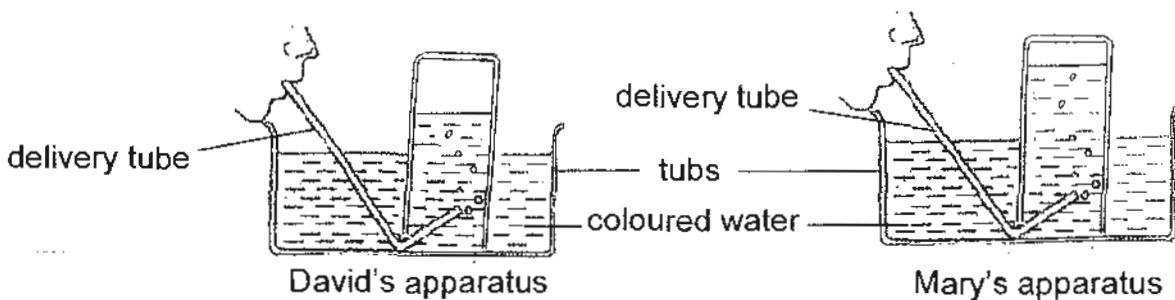
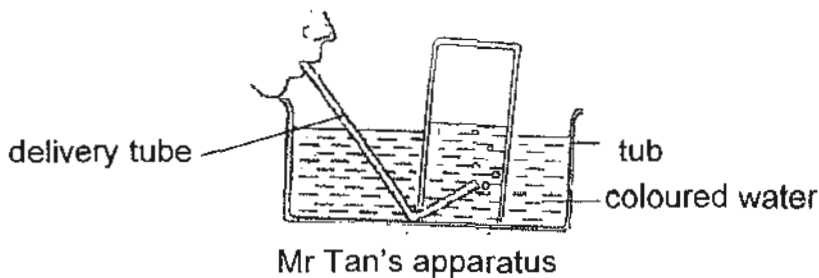

After their experiments, they made the following statements:

Mr Tan : We should take in a deep breath before blowing.

David : My lungs contain more air than Mary but less air than Mr Tan.

Mary : To ensure a fair test, we should blow into inverted glasses of a different size.

Which of them made the correct statement(s)?

- |                           |                          |
|---------------------------|--------------------------|
| (1) David only            | (2) Mary only            |
| (3) Mr Tan and David only | (4) Mr Tan and Mary only |

10. The graph below shows the relative amounts of oxygen and carbon dioxide in the air in a forest.

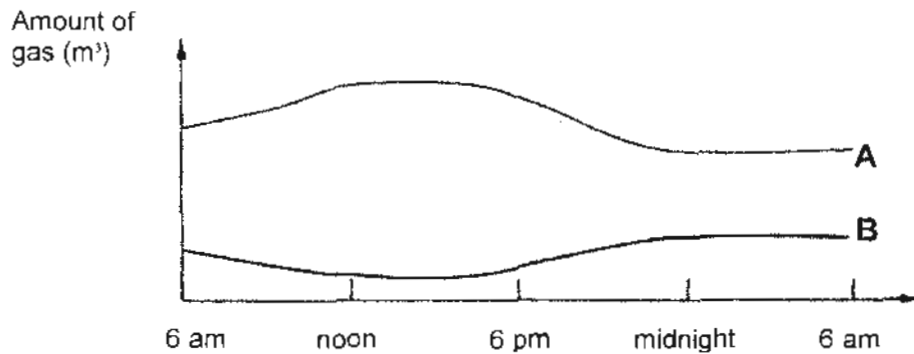

Which one of the following correctly identifies the gas and the process that causes the change in its amount in the air in the forest?

|     |                         |   |
|-----|-------------------------|---|
| (1) | Gas A is oxygen         | During the day, respiration causes it to increase.    |
| (2) | Gas B is carbon dioxide | During the day, respiration causes it to decrease.    |
| (3) | Gas A is oxygen         | During the day, photosynthesis causes it to increase. |
| (4) | Gas B is carbon dioxide | During the day, photosynthesis causes it to increase. |

11. David had 2 similar types of plants, A and B, each placed in identical pots with an equal amount of soil. He wanted to find out the effects of cling wraps on the surfaces of leaves.

For plant A, David covered both sides of the leaves with cling wraps.

For plant B, he covered the upper side of the leaves with cling wraps.

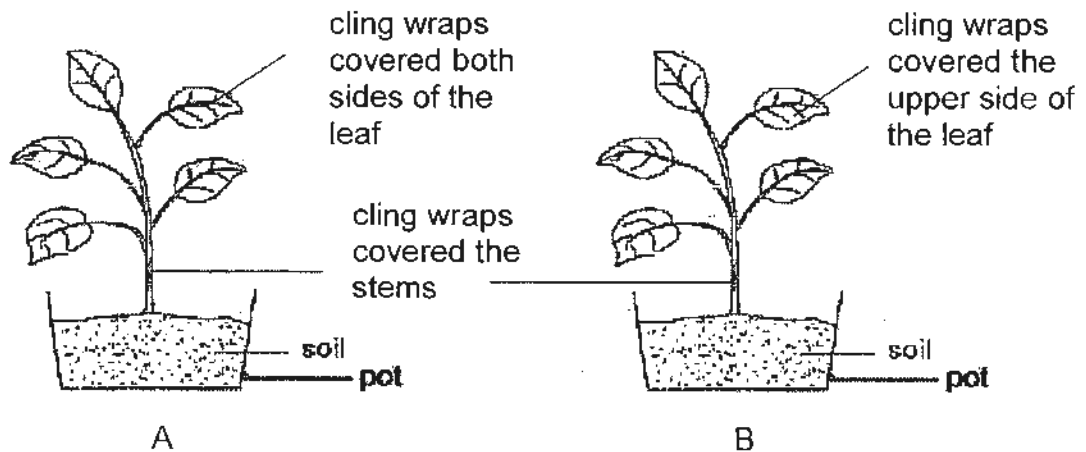

After a few days, David noticed that plant A died but **NOT** plant B.

Which one of the following explains David's observation(s) correctly?

- (1) Water was released through the stomata on the lower surfaces of the leaves of plant B. So the plant continued to carry out photosynthesis.
- (2) Stomata on the upper surfaces of the leaves of plant A were covered. No gaseous exchange took place to allow the plant to carry out photosynthesis.
- (3) Stomata on the lower surfaces of the leaves of plant B allowed gaseous exchange to take place. So the plant was able to carry out photosynthesis.
- (4) Stomata on both surfaces of the leaves of plant A were covered. No water vapour could escape from the plant. The plant died due to excess loss of water.

12. Meiling used the following apparatus to carry out an experiment.

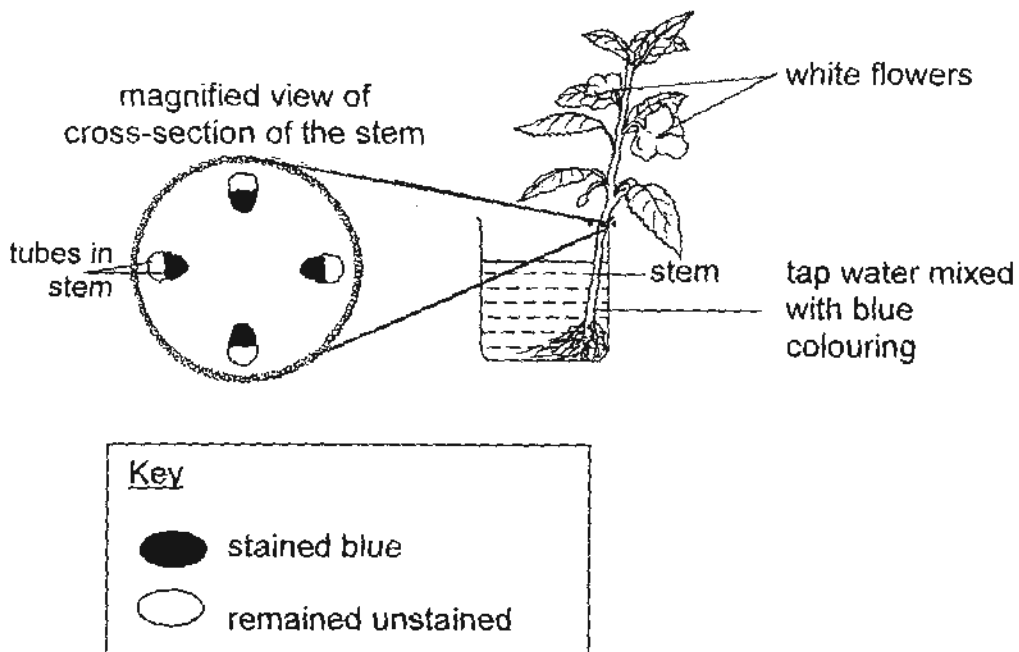

After a day, Meiling cut a cross-section of the stem and observed its cross-sectional view as shown in the diagram above.

What did Meiling observe?

- (1) The water-carrying and food-carrying tubes had turned blue.
- (2) The food-carrying tubes and the white flowers had turned blue.
- (3) The water-carrying tubes and the white flowers had turned blue.
- (4) The white flowers, food-carrying and water-carrying tubes had turned blue.

13. Two fruits of similar size were found growing on a plant. A farmer removed a part of the covering on branch X as shown below.

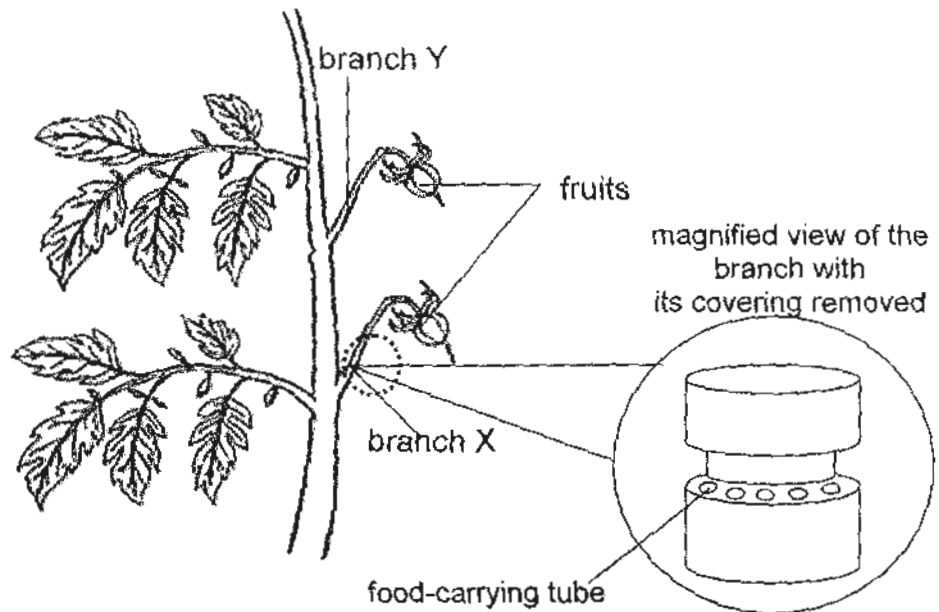

After a few weeks, the farmer noticed that the fruit on branch Y grew bigger.

Which one of the following explains why the fruit on branch X remained small?

- (1) Excess food made by the leaves was stored in the fruit on branch Y.
- (2) Water taken in by the roots was transported to the fruit on branch Y only.
- (3) Excess food made by the leaves could not be transported to the fruit on branch X.
- (4) Water taken in by the roots could not be transported to the leaves nearer to branch X.

14. There are three identical beakers. Beakers A and B contain an equal amount of 500 ml of liquid Y, each of a different temperature.

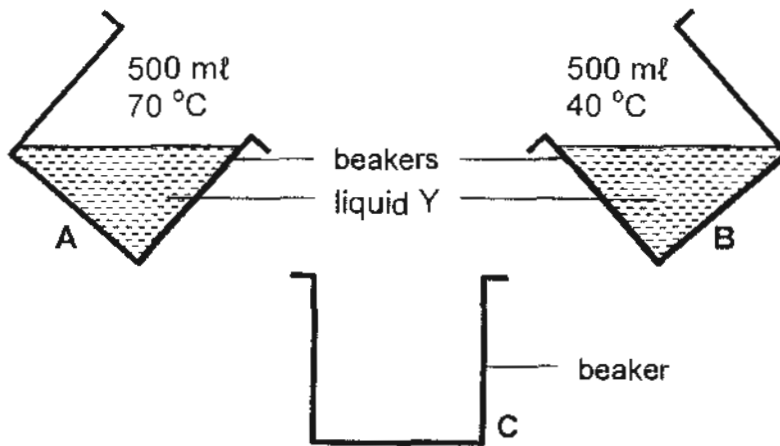

Beaker C is placed in a room at 40 °C.

Once liquid Y from beakers A and B is poured into beaker C, what is the most likely temperature of liquid Y in it?

- (1) 40°C
- (2) between 40°C and 70°C
- (3) between 70°C to 100°C
- (4) above 100°C

15. Mr Chen set up an experiment as shown below.

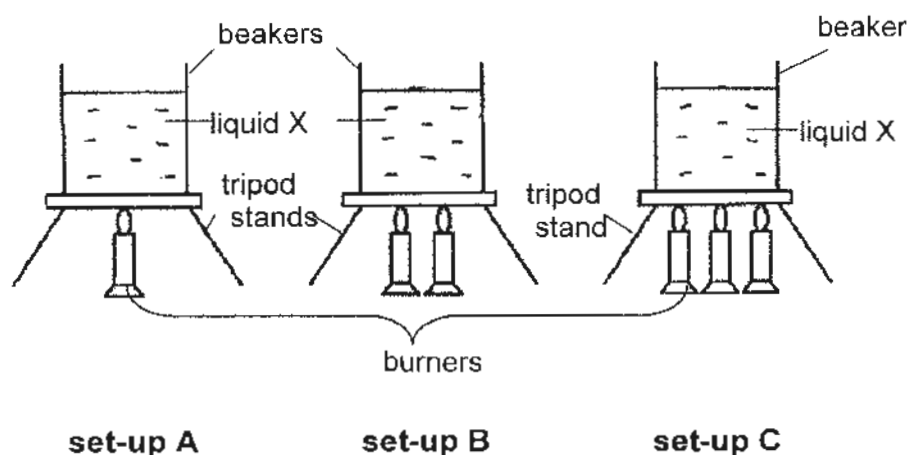

Mr Chen heated liquid X in each beaker until it boiled. At the end of the experiment, his pupils made the following comments:

Chloe : The final temperature of liquid X in all the three set-ups was the same.

Sarah : The liquid X in set-up C reached the highest temperature in the shortest time.

Faith : The liquid X in set-up A was of a lower final temperature than the liquid X in set-up B.

Who made the correct statement(s)?

- |                          |                          |
|--------------------------|--------------------------|
| (1) Faith only           | (2) Sarah only           |
| (3) Chloe and Sarah only | (4) Sarah and Faith only |

16. On a moonless night, Nicole noticed that the length of her shadow changed as she was walking along the path in the direction of the arrow as shown in the diagram below.

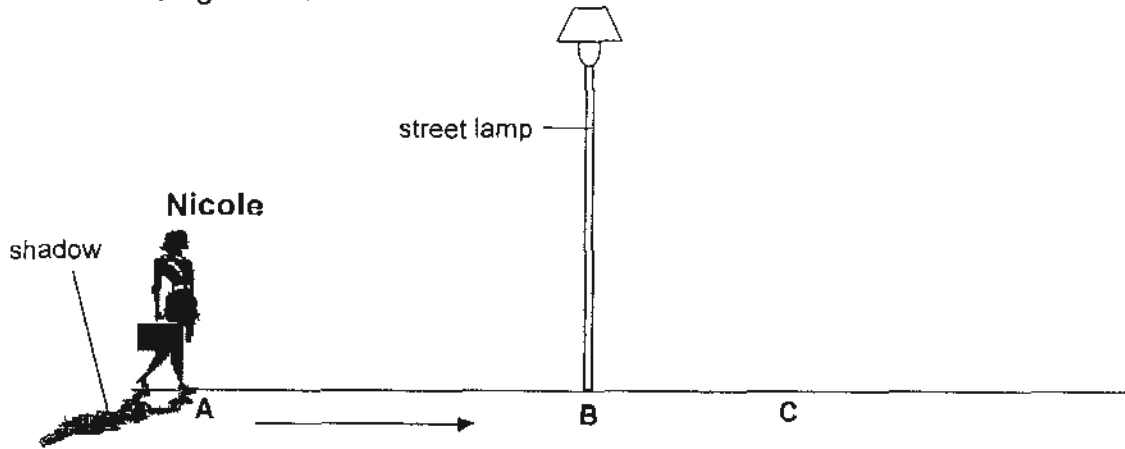

Which one of the following graphs shows the changes in the length of Nicole's shadow as she was moving from A to C?

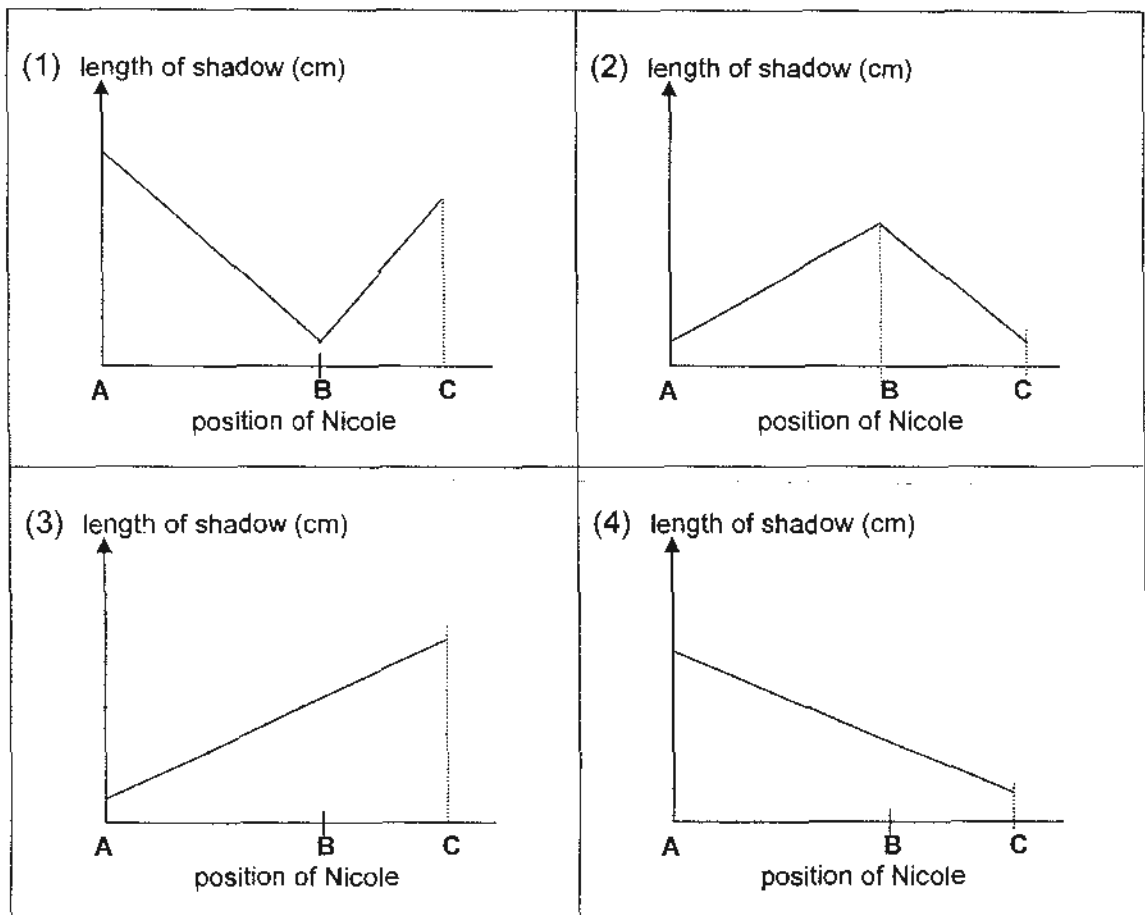

17. Megan had 4 rods, P, Q, R and S, of equal length. Each rod was made of a different material. A pin was attached to each end of the rod with an equal amount of wax.

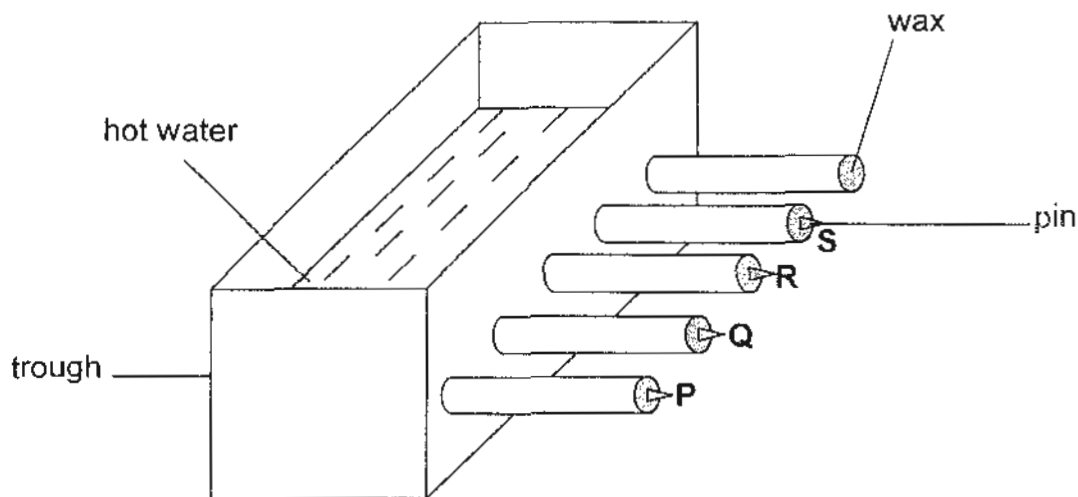

Megan filled the trough with hot water and recorded the time taken for each pin to drop in the table below.

| rod | time taken for the pin to drop off (min) |
|-----|--|
| P   | 5  |
| Q   | 8  |
| R   | 12                                       |
| S   | 10                                       |

Which one of the following identifies the rods correctly?

|     | best conductor of heat | worst conductor of heat |
|-----|------------------------|-------------------------|
| (1) | P                      | R                       |
| (2) | Q                      | S                       |
| (3) | R                      | Q                       |
| (4) | S                      | P                       |

18. Priya conducted her experiment in the same room using identical glasses and containers of the same size. Each container was made of a different material.

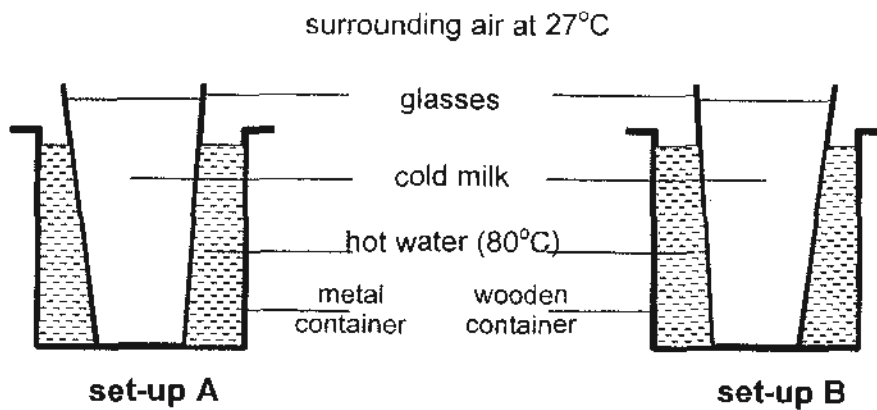

Priya's friends made the following statements:

- Tessa : The milk in set-up B would take a longer time to reach 27°C than the milk in set-up A.
- Claire : The milk in set-up A could not be warmed to a higher temperature than the milk in set-up B.
- Jueun : 3 minutes after the start of the experiment, the rate of evaporation of water in set-up A was faster than the water in set-up B.

Which of Priya's friends made the correct statement(s)?

- (1) Tessa only                      (2) Claire only
- (3) Tessa and Claire only        (4) Tessa and Jueun only

19. A bimetallic strip is made up of 2 different types of metal riveted together so that they cannot move separately.

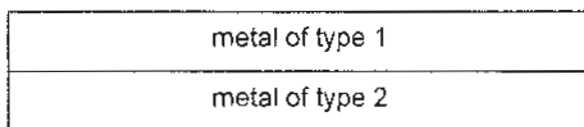

When heated, one metal expands more than the other as shown in **Diagram 2**.

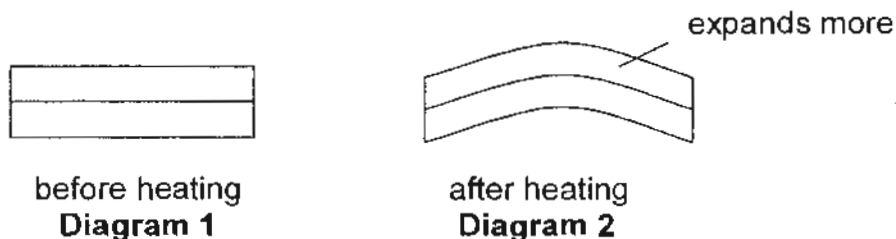

Christine had 4 different types of bimetallic strips. Each of the bimetallic strip was heated with the same amount of heat for the same period of time.

She recorded her observations of each strip as shown in the following diagrams:

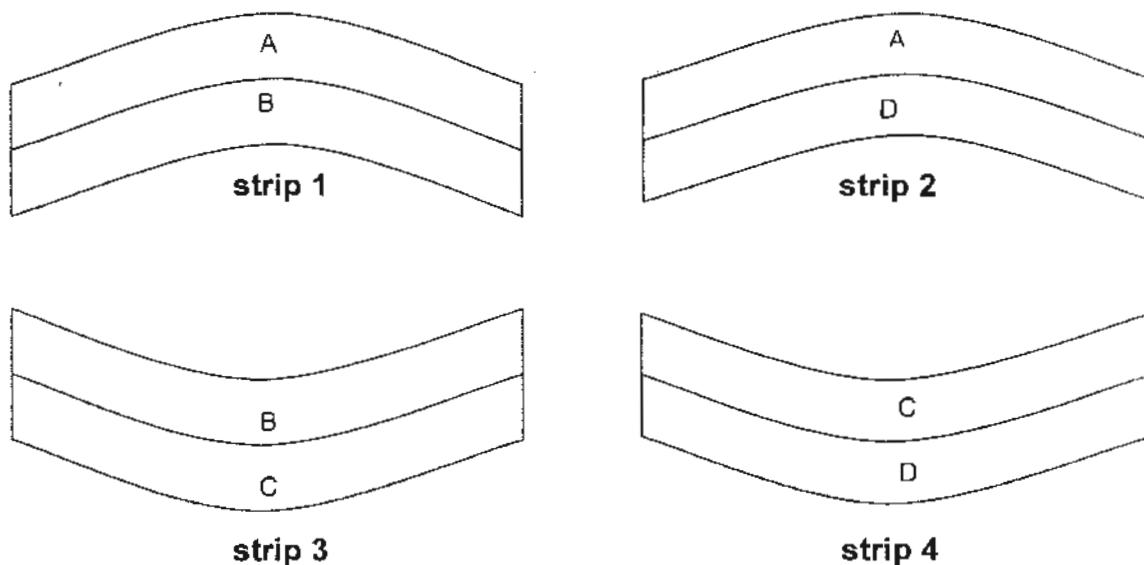

Based on the information above, which one of the following statements about the metal(s) is true?

- (1) Metal B expanded the most.
- (2) Metal A expanded the least.
- (3) Metal C expanded more than metals B and D.
- (4) Metal D expanded more than metal C but less than metal A.

20. Rust is a brownish substance that can form on the surface of iron under certain conditions.

Siti set up an investigation to study the conditions necessary for iron to rust. She suspended 4 identical shiny new iron nails in each tube, A, B, C and D.

Chemical X was put in tube B to keep the air within it dry. All the tubes were left in a room where the amount of water vapour was high during the period of Siti's experiment.

After a few days, Siti took note of the presence of rust on the nails.

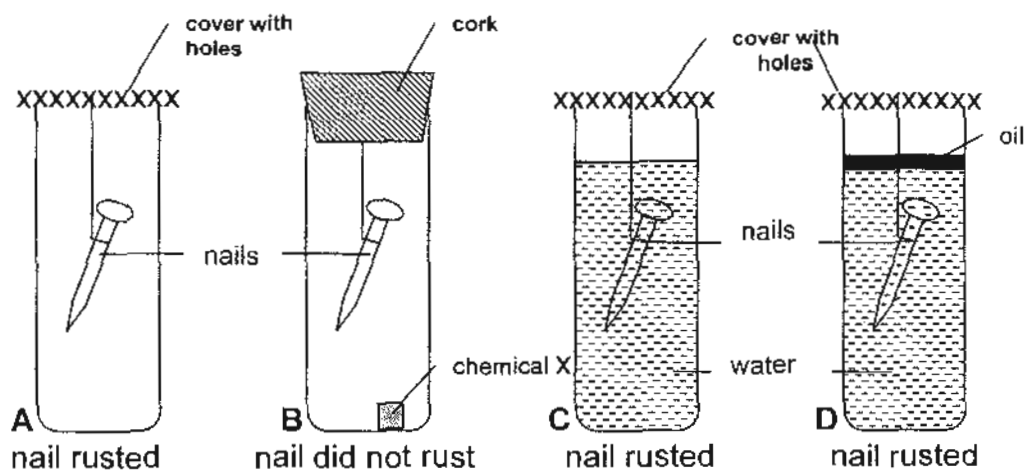

Which one of the following conclusions could Siti possibly make?

- (1) Iron rusts without air.
- (2) Iron rusts without water and air.
- (3) Iron rusts in the presence of air and oil.
- (4) Iron rusts in the presence of water and air.

21. Which one of the following objects is a non-metal but a good conductor of electricity?

- |                   |                    |
|-------------------|--------------------|
| (1) nickel coin   | (2) pencil lead    |
| (3) porcelain cup | (4) aluminium foil |

22. The diagram below shows parts of a bulb.

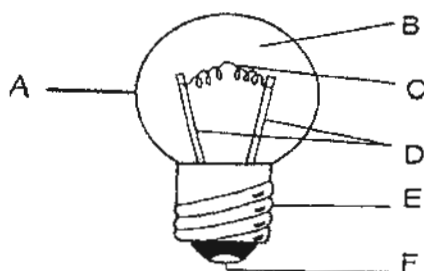

Which parts of the bulb can conduct electricity?

- |                        |                        |
|------------------------|------------------------|
| (1) A, B and C only    | (2) A, D, E and F only |
| (3) B, C, D and F only | (4) C, D, E and F only |

23. Various components are connected to form the electric circuit below.

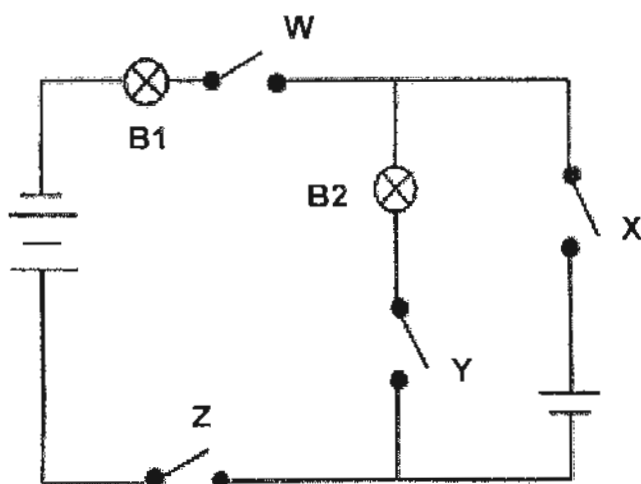

Which of these switches should be **left open** to light up only bulb B1?

- |                  |                     |
|------------------|---------------------|
| (1) W only       | (2) Y only          |
| (3) X and Y only | (4) W, X and Z only |

24. Identical batteries, bulbs and wires are used to set up four different circuits as shown below.

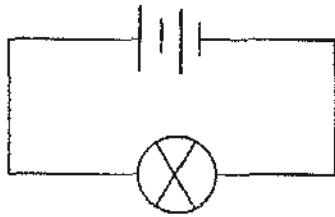

**circuit S**

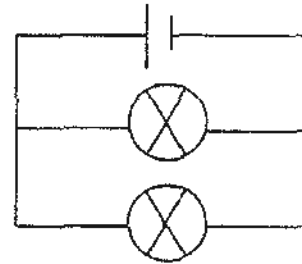

**circuit T**

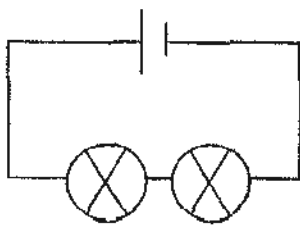

**circuit U**

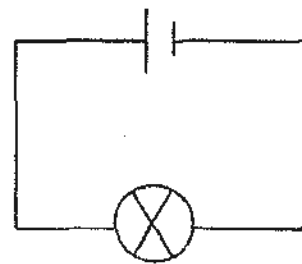

**circuit V**

Which of the following statements about these circuits is/ are correct?

- A Bulb in S is the most brightly lit.
- B Bulbs in U glow most dimly.
- C Bulbs in T and U glow equally bright.
- D Bulb in V glows as brightly as bulb in S.

- (1) D only
- (2) A and B only
- (3) C and D only
- (4) A, B and C only

25. The diagram below shows what is observed when four bars, PQ, RS, TU and WX, of equal length, are suspended side by side.

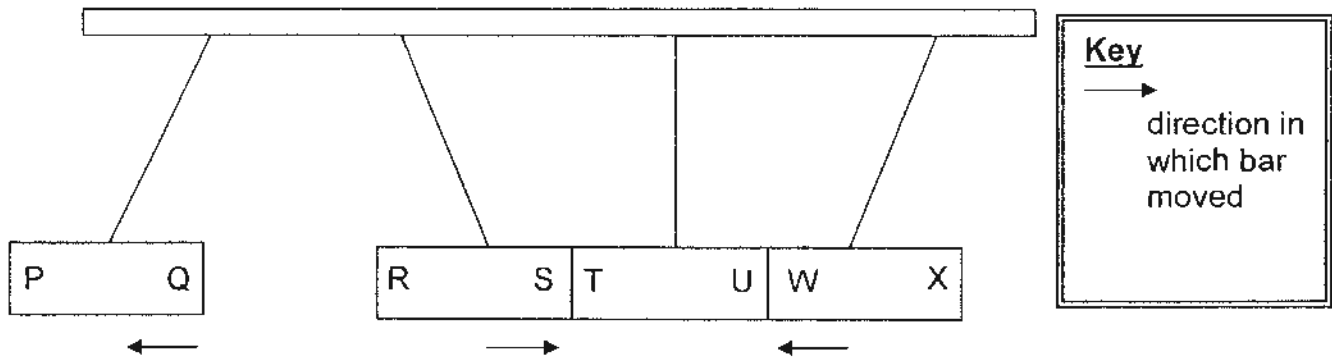

Based on the observations made of the bars, four pupils made the following conclusions:

- Ash : P can repel T.  
 Billy : Q and R are like poles.  
 Cinta : TU is definitely a magnet.  
 Dolly : PQ is made of a non-magnetic material.

Which of these pupils made the correct conclusion(s)?

- (1) Billy only  
 (2) Ash and Billy only  
 (3) Cinta and Dolly only  
 (4) Ash, Billy and Cinta only

Name : \_\_\_\_\_ Index No : \_\_\_\_\_ Class : P5 \_\_\_\_\_

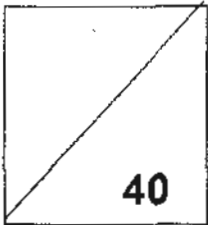

**SECTION B (40 marks)**

For questions 26 to 39, write your answers clearly in the spaces provided.

The number of marks available is shown in the brackets [ ] at the end of each question or part question.

26. Below is the cross-section of a type of flower of a plant that Muthu grows in his garden.

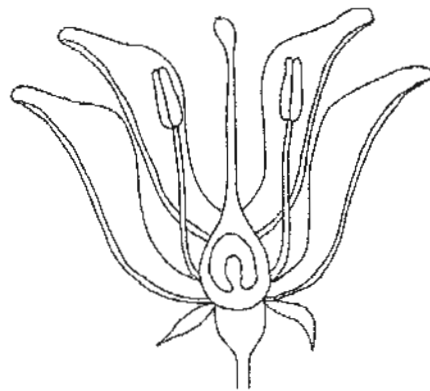

Muthu wanted to find out if a fruit can be produced when a certain part of a flower is removed. He removed different flower parts from each of these flowers, X, Y and Z, as shown below. The flowers X, Y and Z remained growing on the plant.

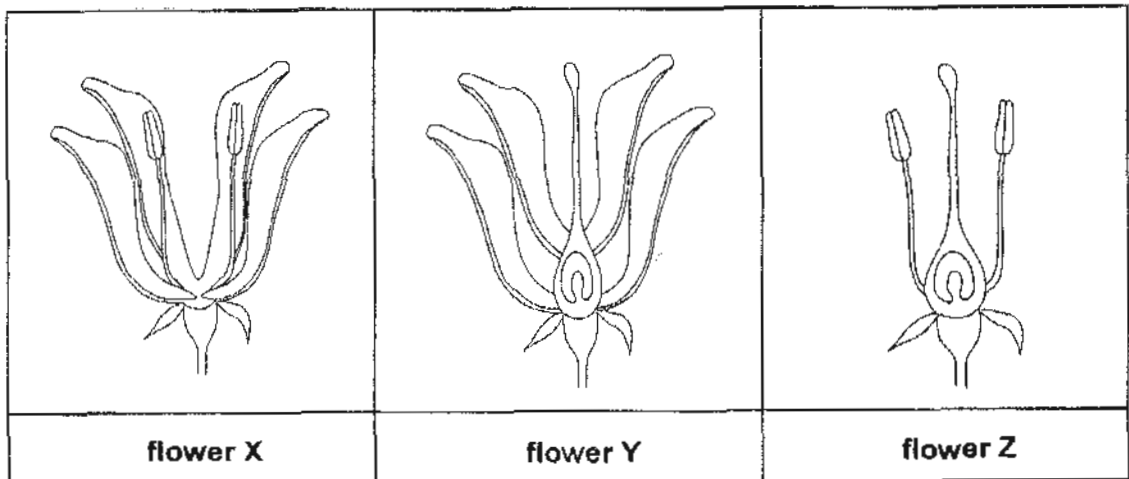

Muthu then dusted pollen grains from the same type of flower over flowers X, Y and Z and observed them over a few weeks.

To be cont'd on the next page

Based on the information on page 23, answer the following questions:

- (a) Which of these flowers was/ were most likely to become a fruit/ fruits? [1]
- 

- (b) In the table below, explain why each of the following flowers could or could **NOT** produce fruits. [2]

| flower | explanation |
|--------|-------------|
| X      |             |
| Z      |             |

27. The diagram below shows a fruit-bearing plant.

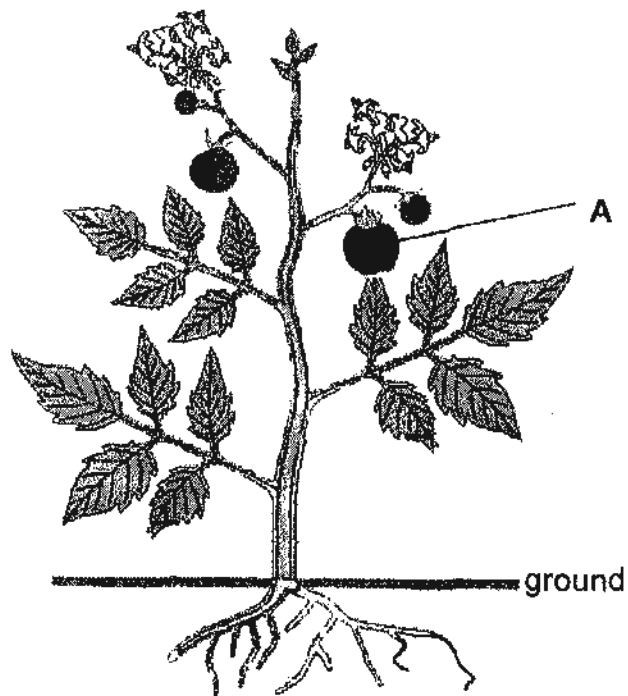

Tom's friend told him that part A prevented the extinction of this type of plant.

- (a) Do you agree with Tom's friend?  
Explain your answer. [2]

---

---

---

- (b) Explain what would happen to the plant when most of its leaves were eaten by pests. [1]

---

---

---

28. The diagram below shows the human digestive system with its parts labelled, A, B, C, D and E.

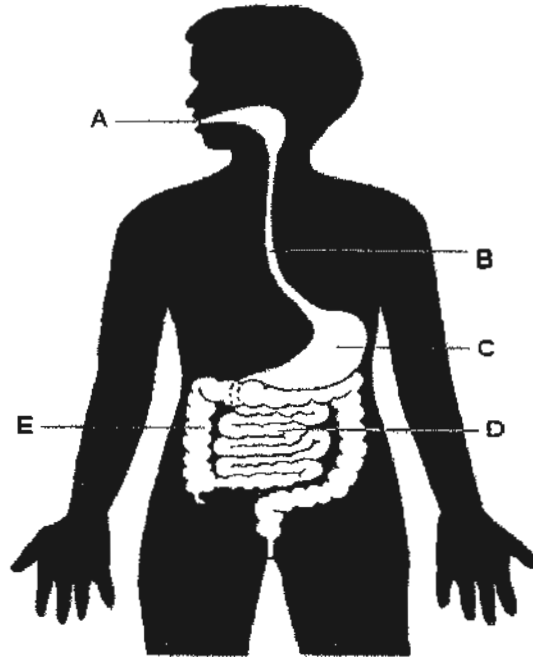

Based on the diagram above, answer the following questions:

- (a) Complete the table below with letters A, B, C, D and <sup>for</sup>E only.

Each letter is to be written **ONCE** only.

[2]

| Function  | part of the system |
|---|--------------------|
| It does not produce any digestive juices  |                    |
| Water is absorbed from undigested food  |                    |
| Digested food enters the bloodstream  |                    |
| More digestive juices are added to break down the partially digested food further |                    |

Digested food is transported by the blood from one part of the body to another.

- (b) Name two **OTHER** substances which can be transported by blood.

[2]

---

29. The table below shows the normal heart rates and breathing rates of some adult mammals at rest.

**NOTE:** The mammals have been arranged according to their body sizes.

increasing size ↑

| mammal  | heart rate /<br>beats per minute | breathing rate /<br>breaths per minute |
|---------|----------------------------------|--|
| giraffe | 46                               | 7                                      |
| human   | 74                               | 18                                     |
| cat     | 245                              | 56                                     |
| mouse   | 620                              | 120                                    |

Based on the information above, answer the following questions:

- (a) State the relationship between the size of the mammals and their heart rates. [1]

---

---

- (b) The heart rate of mammal Z is 130 beats per minute.  
Suggest a reasonable breathing rate per minute of mammal Z. [1]

---

Compare the body size of mammal Z with that of the following mammals.

- (c) Complete the blanks with the words given in the box below: [1]

smaller than                      of the same size as                      bigger than

Mammal Z is \_\_\_\_\_ the mouse but  
\_\_\_\_\_ the human.

30. The following diagram shows an onion with its parts labelled.

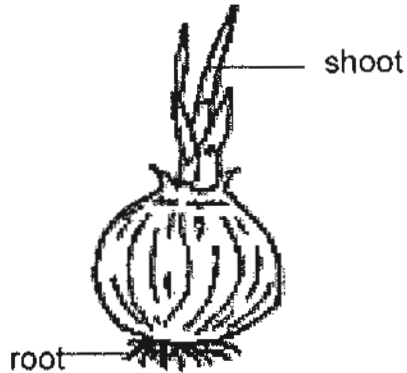

The following cells, Y and Z, are taken from these parts of the onion.

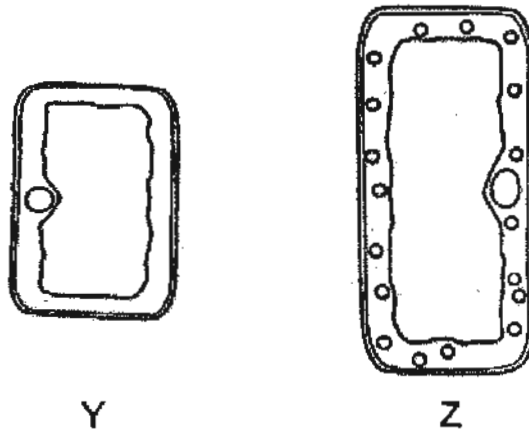

(a) Complete each of the following blanks with a suitable word. [1]

- (i) Cell Y is most likely to be taken from the \_\_\_\_\_ of the onion.
- (ii) Cell Z is most likely to be taken from the \_\_\_\_\_ of the onion.

(b) Give a reason for each of your answers in (a). [2]

| cell | reason |
|------|--------|
| Y    |        |
| Z    |        |

31. The diagram below shows an opening, X, which is found on the underside of a leaf.

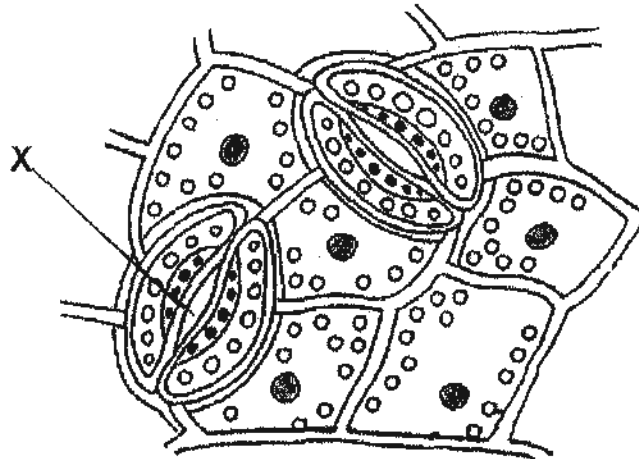

- (a) State one function of X. [1]

---

Bala's teacher told him that plants with such leaves cannot survive in the desert where there is little amount of water.

- (b) Why did Bala's teacher say so? [1]

---

---

32. Farhan had three identical jars with an equal amount of indicator X. He placed two animals of type P of similar size in set-ups B and C as shown in the diagrams below.

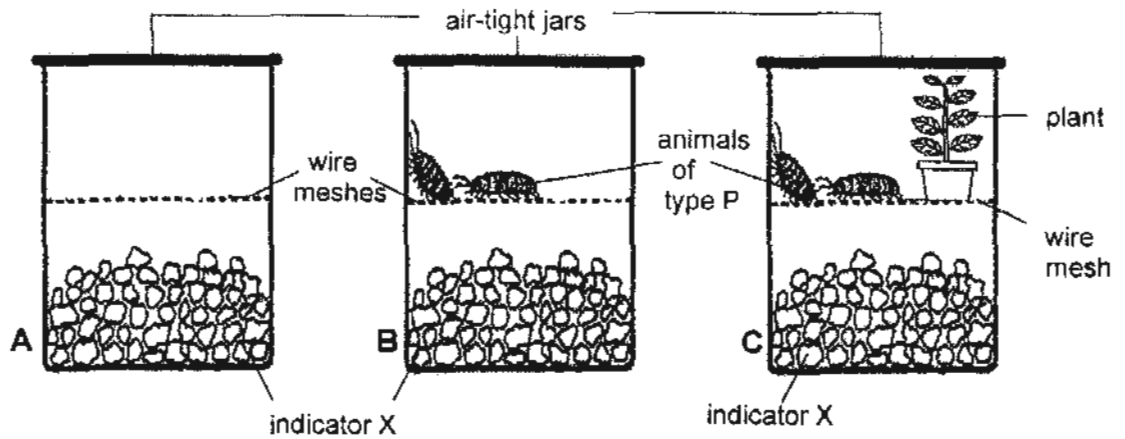

Farhan placed the 3 set-ups in a dark room for an hour. The colour of indicator X was purple at the beginning of the experiment.

After an hour, Farhan noticed that the colour of indicator X changed according to the amount of carbon dioxide present in each set-up. He recorded his observations on a scale as follows:

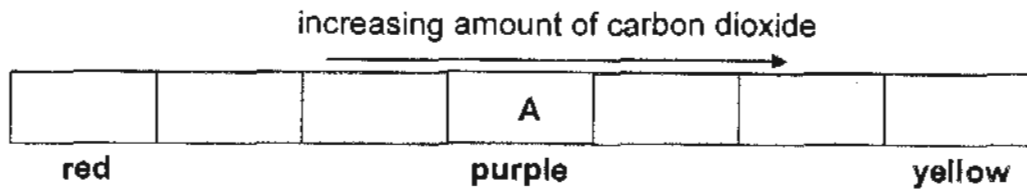

Based on the information above, compare set-ups B and C.

Using the given scale above, write letters B and C **ONCE** only in the appropriate box(es) to show the results of set-ups B and C.

Explain your answers.

[2]

---



---



---

33. To study the relationship between the amount of plants and the rate of photosynthesis, Amy had two set-ups, A and B, placed at the window during the day as shown in the diagrams below.

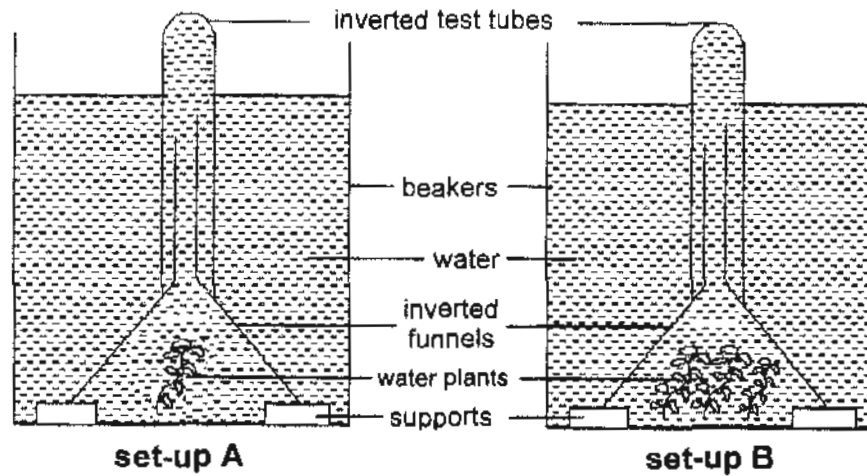

After 2 hours, Amy measured and recorded the heights of the test tubes NOT filled with water,  $h_1$  and  $h_2$ , and made a comparison.

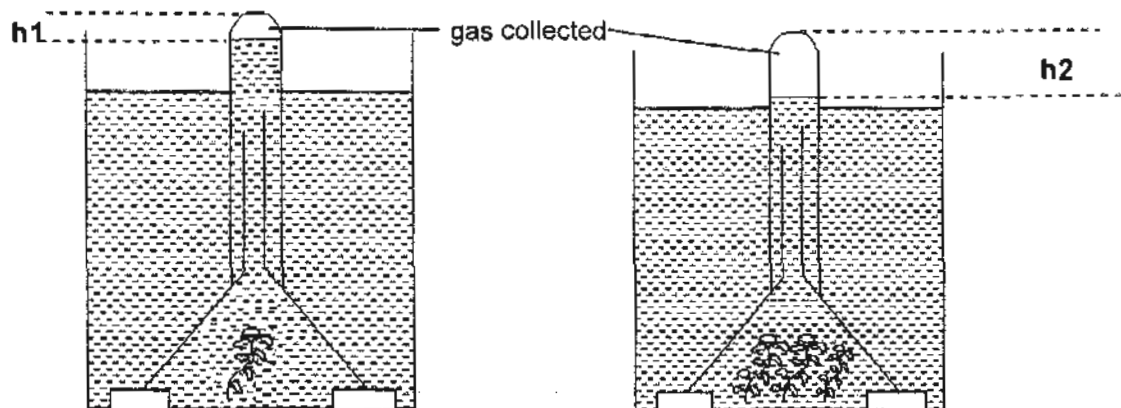

**NOTE:** The gas produced during photosynthesis was greater than the gas produced during respiration.

Based on the information above, answer the following questions:

- (a) Name the gas collected in the test tubes. [1]

\_\_\_\_\_

to be cont'd on the next page

Amy plotted the graph below to show the difference between h1 and h2.

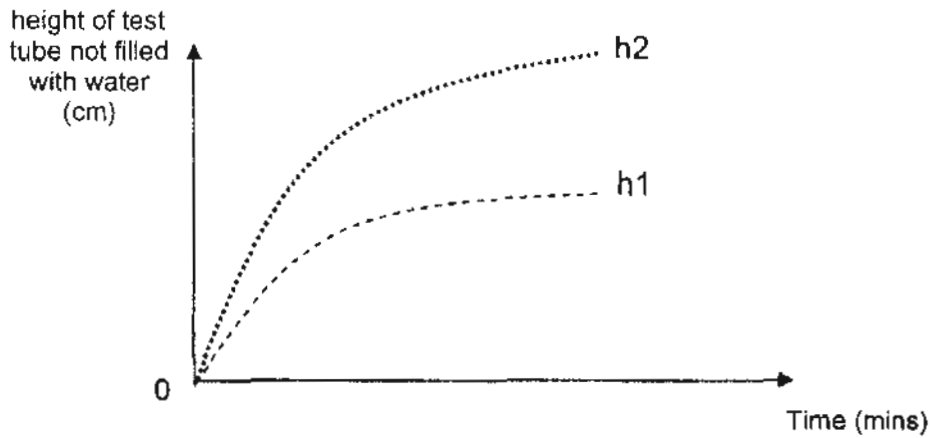

- (b) What had caused the difference in the amount of gas collected in both test tubes? [1]

---



---



---

Amy conducted **ANOTHER** experiment using the following apparatus as shown below.

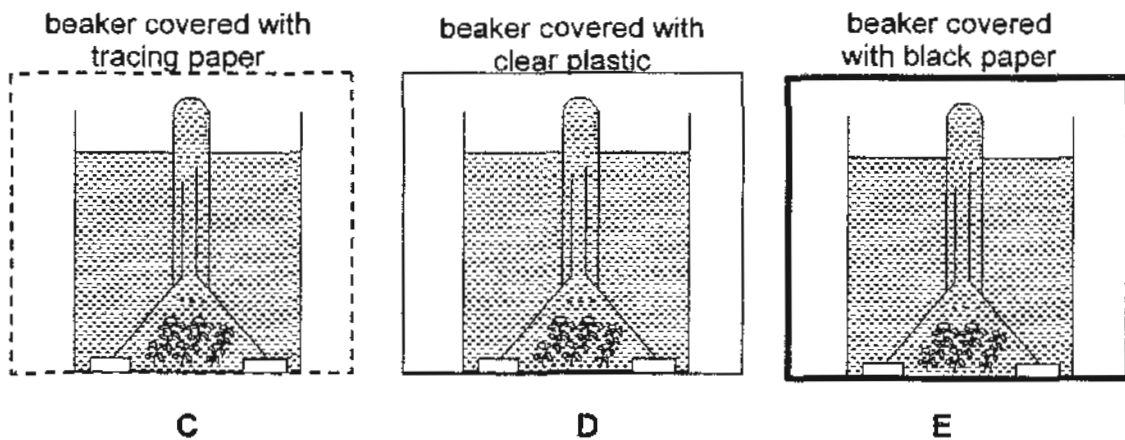

Amy placed the 3 set-ups, C, D and E, under the sun for two hours. After 2 hours, she noticed that there was a difference in the amount of gas collected in the inverted test tubes.

- (c) Write down the correct order of set-ups according to the amount of gas collected in the inverted test tubes.  
Write down letters C, D and E **ONLY**. [1]

increasing amount of gas collected

34. Ben tied a plastic bag over parts of a plant and placed it in a container of water with a layer of oil as shown in the diagram below.

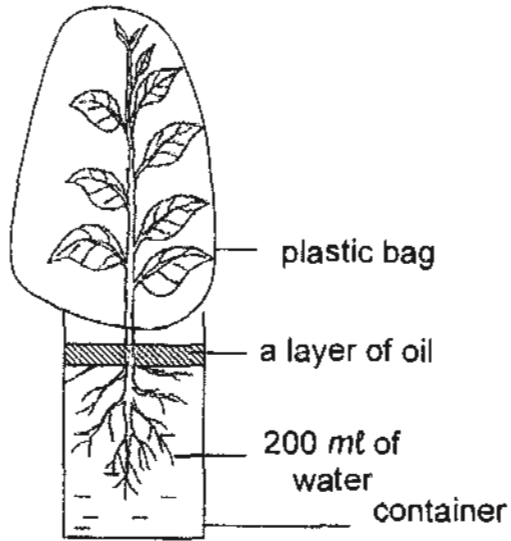

The next day, Ben noticed that water droplets had formed on the inner surfaces of the plastic bag.

- (a) Where did the water droplets come from? [1]

---

---

Next, Ben removed the plastic bag over the plant and balanced it with an equal amount of mass, X, on a balance as shown below.

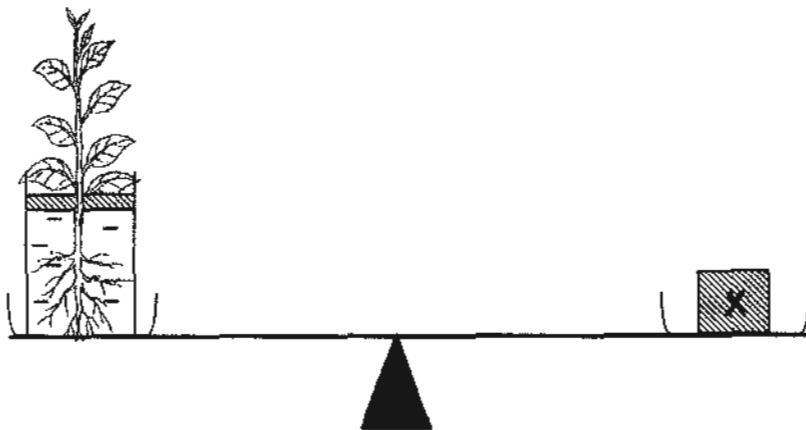

To be cont'd on the next page

After two days, Ben noticed that the balance had tilted to one side.

- (b) In the box below, **DRAW** Ben's observations of the balance and explain what could possibly caused it to tilt. [3]

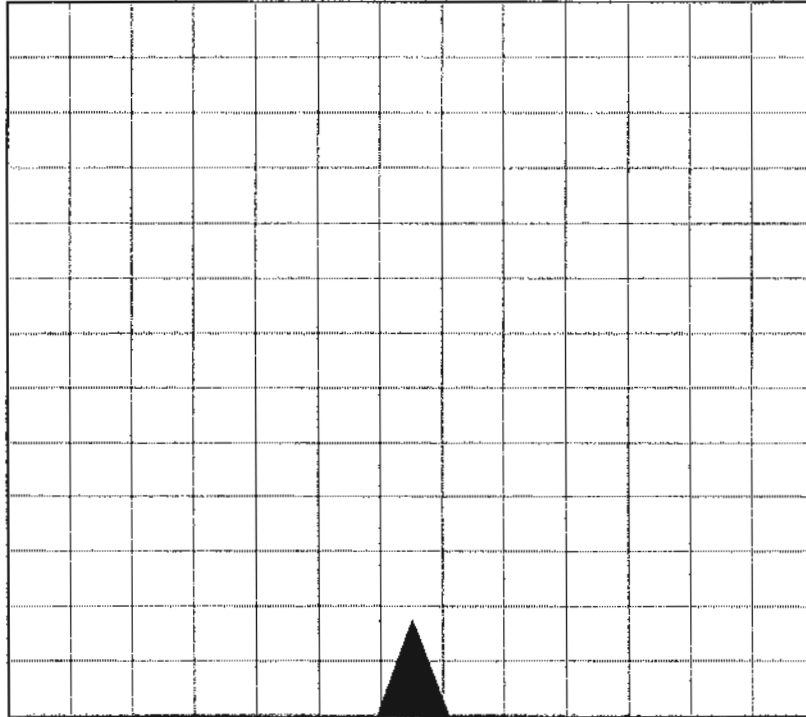

---

---

---

---

35. A glass lid was placed over a pot of hot soup as shown in the diagram below.

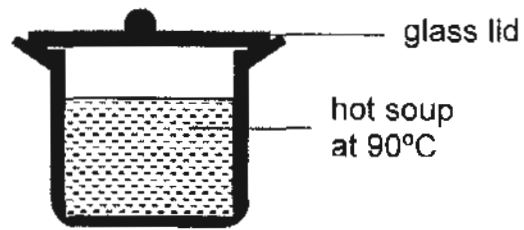

After a few minutes, water droplets were observed.

- (a) **DRAW** the water droplets to indicate where they were formed. [1]
- (b) Explain how these water droplets were formed. [2]

---

---

---

36. The diagram below shows four different objects of different dimensions.

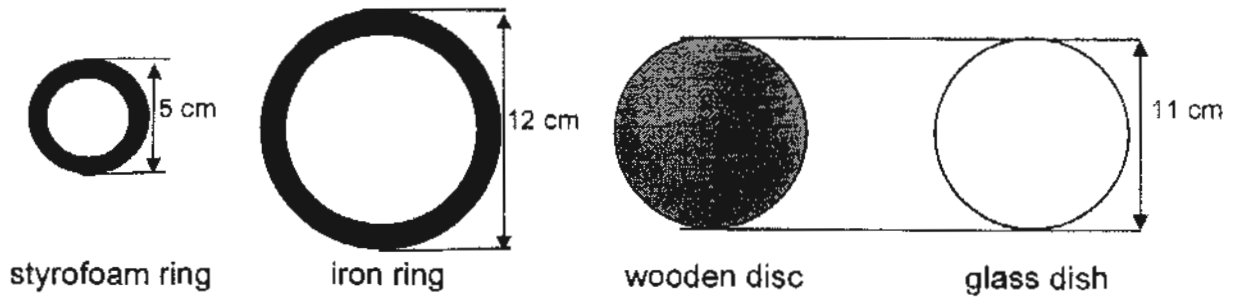

John placed two objects at positions X and Y between the light source and a screen as shown below.

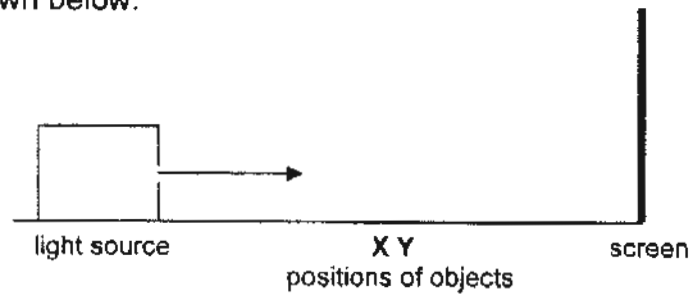

John saw the following shadow formed on the screen.

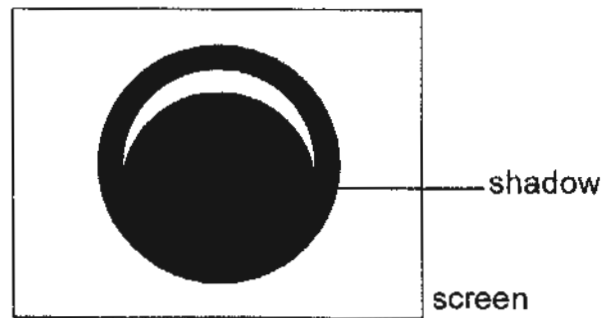

(a) Name the two objects which John had used to form the shadow seen on the screen. [1]

---

(b) State the property of light shown in this experiment. [1]

---



---

37. Various components were connected to form an electric circuit as shown below.

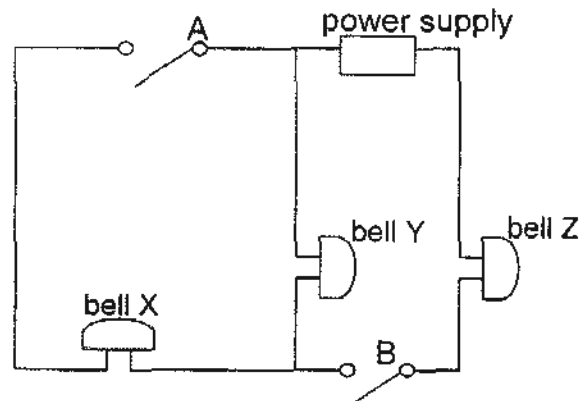

- (a) Which of these bells, X, Y and/ or Z, rang in each of the following situations?

Put a tick ( ✓ ) in the appropriate box(es) below.

[2]

| situation                           | bell(s) that rang |   |   |
|-------------------------------------|-------------------|---|---|
|                                     | X                 | Y | Z |
| (i) Switches at A and B were closed |                   |   |   |
| (ii) Only switch at B was closed    |                   |   |   |

Switch at B was removed.

Rod C, made of a certain material, was used to replace B.

Switch at A remained closed. All the bells X, Y and Z did **NOT** ring at all.

- (b) What can be said about the material of rod C?

[1]

---



---

38. Juliana set up two circuits, P and Q, with an iron nail suspended between two identical iron rods, A and B, each with an equal number of coils of wire around it.

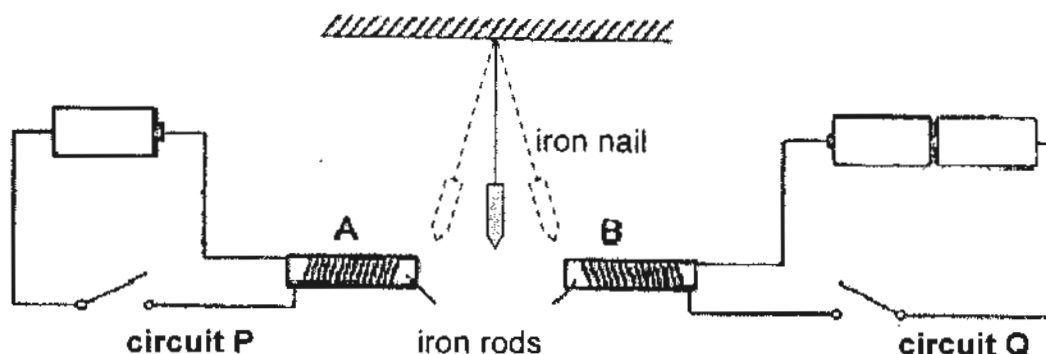

The switches of both circuits P and Q were closed.

- (a) Compare the magnetic strength of iron rods A and B.

Which one of these rods, A or B, had a stronger magnetic strength?  
Explain your answer. [1]

---



---



---



---

- (b) Describe what happened to the iron nail. [1]

---



---

**ANOTHER** two identical batteries were connected in series in circuit P.

- (c) What would happen to the suspended iron nail? [1]

---



---

39. Sami wanted to play with his iron toy car. He placed 2 different tables of the same size and height side by side. Each tabletop of the same thickness was made of a different material.

Sami put his iron toy car on one end of a tabletop. Next, he placed a strong bar magnet directly below the toy car.

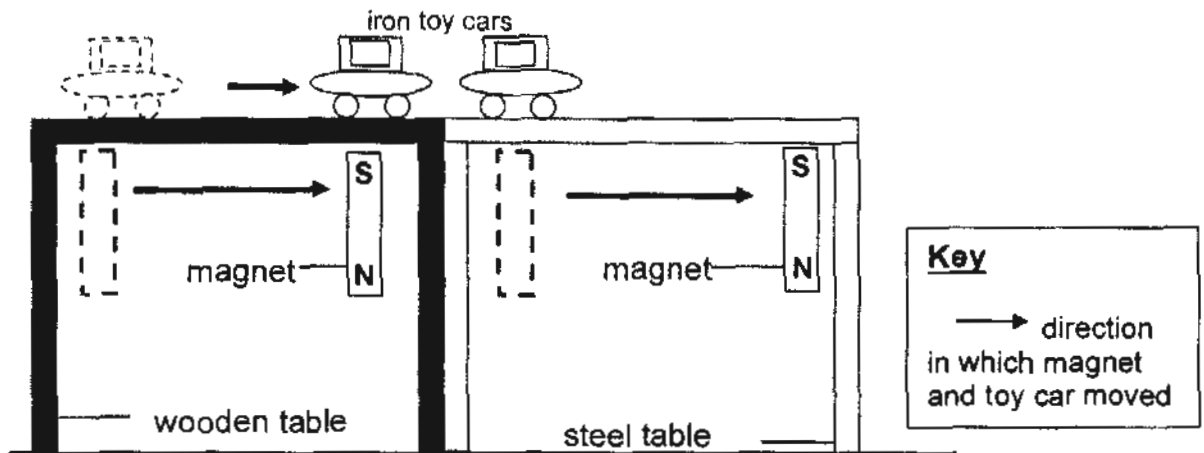

Sami moved the magnet to and fro under each tabletop and recorded the following observations:

| observations  |                             |
|---|-----------------------------|
| when magnet was directly below toy car which was on |                             |
| wooden tabletop                                     | steel tabletop              |
| toy car moved in the same direction as the magnet   | toy car did <b>NOT</b> move |

Curious about his observations, Sami conducted an experiment by placing a hanging magnet above a paper clip attached to a weight by a thread.

The magnet pulled the paper clip up as shown in the diagram below.

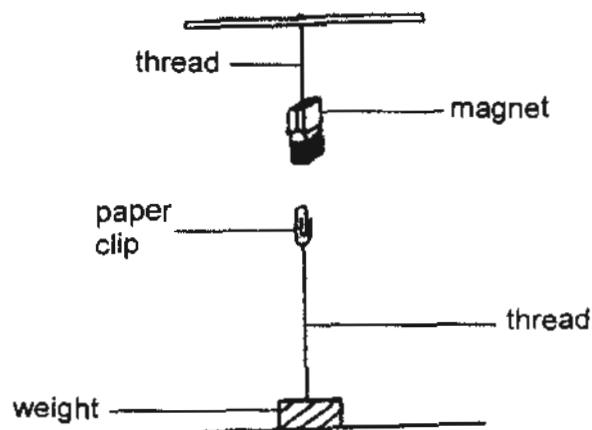

To be cont'd on the next page

Next, Sami placed four identical-sized sheets, each of a different material, between the same magnet and paper clip as shown in set-ups A, B, C and D.

He found that the paper clip remained where it was for only set-ups C and D as shown in the diagrams below.

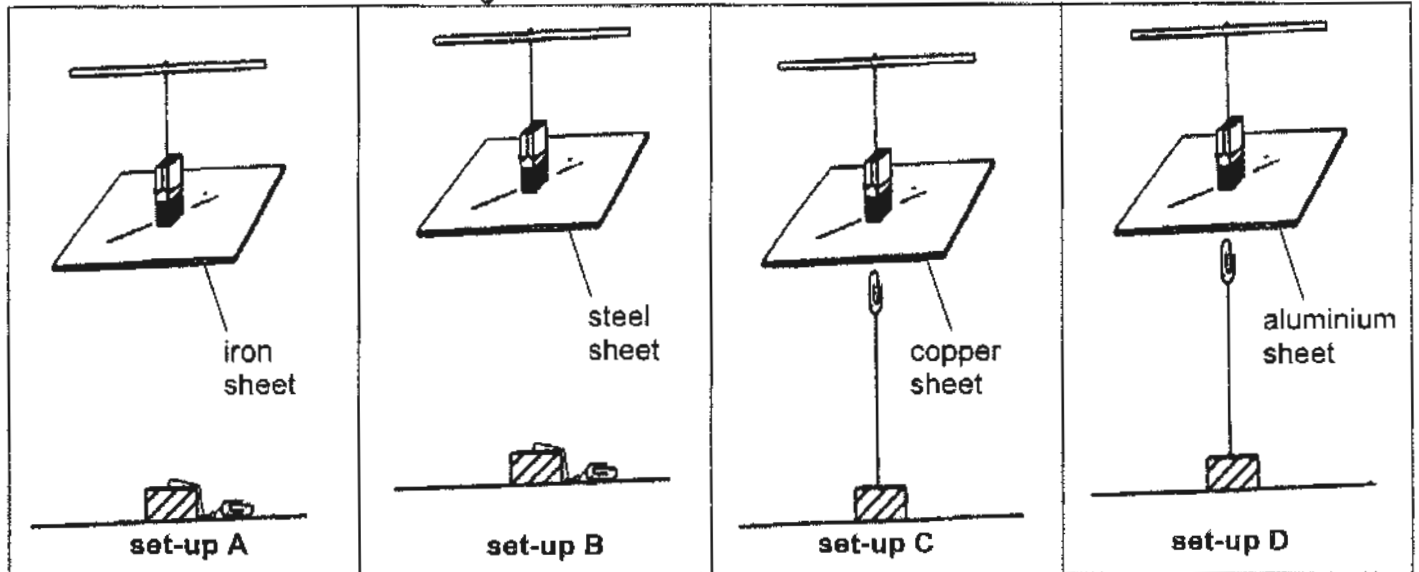

Based on the information above, answer the following questions:

- (a) What could Sami conclude about magnetic force from his experiment? [1]

---



---

- (b) Suggest **ANOTHER** material of the sheet which Sami could place between the magnet and the paper clip to get the same result as shown in set-up D. [1]

---

- END OF PAPER -

Setters: Mdm Prisca Fernandez, Mr Tan Siew Whatt, Ms Aishah, Mdm Neo Hwee Lee



**RAFFLES GIRLS' PRIMARY SCHOOL**  
**2010 PRIMARY 5 SCIENCE SA 2 ANSWER KEY**  
 Please do NOT print the answer key for the pupils

Setters : \* Mdm Prisca Fernandez (section A), Mr Tan Siew Whatt (section B), Ms Aishah,  
 Mdm Neo Hwee Lee \*compiler

**SECTION A (25 X 2 marks)**

|   |   |
|---|---|
| 1 | 1 |
| 2 | 1 |
| 3 | 2 |
| 4 | 1 |
| 5 | 1 |

|    |   |
|----|---|
| 6  | 4 |
| 7  | 4 |
| 8  | 1 |
| 9  | 3 |
| 10 | 3 |

|    |   |
|----|---|
| 11 | 3 |
| 12 | 3 |
| 13 | 3 |
| 14 | 2 |
| 15 | 3 |

|    |   |
|----|---|
| 16 | 1 |
| 17 | 1 |
| 18 | 2 |
| 19 | 4 |
| 20 | 4 |

|    |   |
|----|---|
| 21 | 2 |
| 22 | 4 |
| 23 | 2 |
| 24 | 2 |
| 25 | 1 |

**SECTION B (40 marks)**

| No. | Marks  | Suggested answers   | Remarks   |
|-----|--------|---|---|
| 26  | a<br>1 | Y and Z   | NO partial marks  |
|     | b<br>2 | <p>[1] Flower X</p> <p>Without the</p> <ul style="list-style-type: none"> <li>▪ stigma,</li> <li>▪ ovaries,</li> <li>▪ ovules,</li> <li>▪ stigmas and ovaries,</li> <li>▪ stigmas and ovules,</li> <li>▪ female part(s)</li> </ul> <p>} [½]</p> <p>fertilisation / fertilization <u>cannot</u> take place<br/>           OR<br/>           male sex/reproductive cell/part <u>cannot</u> fuse with the female sex/reproductive cell/part.<br/>           OR<br/>           male and female sex/reproductive cells/parts/system <u>cannot</u> go through <b>sexual reproduction</b>. [½]</p> <p>[1] Flower Z</p> <p>With the</p> <ul style="list-style-type: none"> <li>▪ stigma,</li> <li>▪ ovaries,</li> <li>▪ ovules,</li> <li>▪ stigmas and ovaries,</li> <li>▪ stigmas and ovules,</li> <li>▪ female part(s)</li> </ul> <p>} [½]</p> <p>fertilisation / fertilization can take place<br/>           OR<br/>           male sex/reproductive cell/part can fuse with the female sex/reproductive cell/part<br/>           OR<br/>           the male and female sex/reproductive cells/parts/system can go through <b>sexual reproduction</b>. [½]</p> | <p>-[½] for wrong spelling of words in bold</p> <p>NOT acceptable:</p> <ul style="list-style-type: none"> <li>▪ pollen grains / pollen fuses/fertilizes</li> <li>▪ negative statements</li> </ul> |

|    |   |   |   |  |
|----|---|---|---|--|
|    | a | 2 | <ul style="list-style-type: none"> <li>• Yes, Part A has seeds [1] which will             <ul style="list-style-type: none"> <li>- grow into new plants</li> <li>- reproduce</li> <li>- germinate</li> <li>- be planted again</li> </ul> </li> </ul>  |  |
| 27 | b | 1 | <ul style="list-style-type: none"> <li>• No, it is the seeds which prevent the extinction of the plant, not the fruit [0]</li> <li>• No, it is not the fleshy part of the fruit which prevents the extinction of the plant but the seed [2]</li> </ul> <p><u>Plant will die</u></p> <ul style="list-style-type: none"> <li>• Without leaves, the plant cannot/could not/no longer photosynthesise [1/2] and died/wither/stopped growing. [1/2]</li> <li>• The plant died [1/2] because there are not enough leaves to make sufficient food for the plant. [1/2]</li> <li>• The plant died because the leaves cannot photosynthesise. [0]</li> <li>• The plant will die as leaves are the ones that carry out photosynthesis to make food. [0]</li> <li>• The plant will die. [0]</li> </ul> <p><u>Plant will not die</u></p> <ul style="list-style-type: none"> <li>• The plant will not die and will get its food from Part A. [1/2] In the meantime it will also grow new leaves and continue making food for itself. [1/2]</li> <li>• The plant will continue to survive as new/young leaves started to develop [1/2] and make sufficient food for the plant. [1/2]</li> </ul> |  |

| No.   | Marks  | Suggested answers  | Remarks   |   |  |  |  |          |                                      |          |   |                                |   |
|---|--|--|---|---|--|--|--|----------|--------------------------------------|----------|---|--------------------------------|---|
| 28  | a  | <p> <b>B</b>                      <b>B, E</b>    [1/2]<br/> <b>E</b>                      <b>A</b>        [0]<br/> <b>D</b>                      <b>D</b>        [1/2]<br/> <b>C</b>                      <b>C</b>        [1/2] </p> <p>           -If pupils write the A, B, C or D more than once, both answers will be [0]<br/>           -If pupils write more than one alphabet in a box (with the exception of the above) [0] </p> <table border="1"> <thead> <tr> <th>Function</th> <th>part of the system</th> </tr> </thead> <tbody> <tr> <td>It does not produce any digestive juices</td> <td> <b>B</b><br/>           E – NOT acceptable<br/>           E – acceptable only when NO other box has the answer </td> </tr> <tr> <td>Water is absorbed from undigested food</td> <td><b>E</b></td> </tr> <tr> <td>Digested food enters the bloodstream</td> <td><b>D</b></td> </tr> <tr> <td>More digestive juices are added to break down the partially digested food further</td> <td> <b>C</b><br/>           A – NOT acceptable </td> </tr> </tbody> </table> | Function  | part of the system  | It does not produce any digestive juices | <b>B</b><br>E – NOT acceptable<br>E – acceptable only when NO other box has the answer | Water is absorbed from undigested food | <b>E</b> | Digested food enters the bloodstream | <b>D</b> | More digestive juices are added to break down the partially digested food further | <b>C</b><br>A – NOT acceptable | <p>[½] for each correct answer</p> <p>Do NOT accept</p> <ul style="list-style-type: none"> <li>E : does not contain any digestive juices (answer E is used in another answer)</li> <li>A : more digestive juices are added (clue is more digestive juices)</li> </ul> |
|   | Function   | part of the system   |   |   |  |  |  |          |                                      |          |   |                                |   |
| It does not produce any digestive juices  | <b>B</b><br>E – NOT acceptable<br>E – acceptable only when NO other box has the answer |  |   |   |  |  |  |          |                                      |          |   |                                |   |
| Water is absorbed from undigested food  | <b>E</b>   |  |   |   |  |  |  |          |                                      |          |   |                                |   |
| Digested food enters the bloodstream  | <b>D</b>   |  |   |   |  |  |  |          |                                      |          |   |                                |   |
| More digestive juices are added to break down the partially digested food further | <b>C</b><br>A – NOT acceptable   |  |   |   |  |  |  |          |                                      |          |   |                                |   |
| b   | 2  | <p><u>Accepted</u></p> <ul style="list-style-type: none"> <li>oxygen</li> <li>carbon dioxide</li> <li>waste materials/waste/waste product</li> <li>water</li> </ul> <p><u>NOT accepted</u></p> <ul style="list-style-type: none"> <li>nutrients</li> <li>digested food</li> <li>air</li> <li>oxygenated blood</li> <li>deoxygenated blood</li> </ul>   | <p>Any two of the acceptable answers</p> <p>[1] for each correct answer</p> <p>NOT acceptable</p> <ul style="list-style-type: none"> <li>nutrients</li> <li>digested food</li> <li>air</li> </ul> <p>-[½] for each wrong spelling</p> |   |  |  |  |          |                                      |          |   |                                |   |
| 29  | a  | <p><b>Concept:</b><br/> <b>Inverse relationship between size of mammal and rate of heart beat</b></p> <p>The bigger the mammals, the slower the heart beat / rate / pumps</p> <p>The smaller the mammals, the faster the heart beat / rate / pumps</p>   | <p>0 m breathing rate</p>   |   |  |  |  |          |                                      |          |   |                                |   |
|   | b  | 1  | <p>Accept any answer</p> <p>between 18 and 56 breaths per minute</p>  | <p>-[½] for</p> <ul style="list-style-type: none"> <li>NO units</li> <li>wrong unit</li> <li>wrong spelling of breaths/ minute (word is given)</li> </ul> |  |  |  |          |                                      |          |   |                                |   |

|  |          |          |                             |   |
|--|----------|----------|-----------------------------|---|
|  | <b>c</b> | <b>1</b> | bigger than<br>smaller than | <b>NO partial marks</b><br><b>Mark holistically</b><br>-[½] for wrong spelling of words<br>(spelling is given in the box) |
|--|----------|----------|-----------------------------|---|

| No. | Marks | Suggested answers   | Remarks   |
|-----|-------|---|---|
| 30  | a     | 1<br>(i) roots / skin<br>(ii) shoots  | 0 m for<br>(ii) stem<br>(ii) leaves   |
|     | b     | 2<br>Y: does not have chloroplast [1m]<br>Z: has chloroplast [1m]<br>Y: does not need/have chlorophyll ... [½m]<br>Z: needs/have chlorophyll... [½m]  | [0 m]<br>If no mention of chloroplast or chlorophyll, but just explains about making food or photosynthesis |
| 31  | a     | 1<br>[1] To allow<br>▪ gaseous exchange to take place<br><br>[½] Partial correct answers<br>To allow<br>▪ water vapour to escape to the surrounding during respiration<br>▪ oxygen to enter during respiration<br>▪ carbon dioxide to escape during photosynthesis<br><br>In addition to the original already given, please note the following;<br><br>31a)<br>• exchange of gases [1]<br>• allows oxygen to enter and carbon dioxide to escape from the plant (or vice-versa) [1]<br>• takes in air [0.5]<br>• gets rid of excess water in the form of water vapour [0.5]<br>• water vapour to escape to the surroundings [0.5]<br>• oxygen to enter [0.5]<br>• carbon dioxide to escape / enter [0.5]<br>• allow plants to breathe / respire / transpire [0]<br>• prevents excess water loss [0]<br>• it does / makes the gases exchange in plants [0]<br>wrong concept | -[½] for wrong spelling of words in bold  |
|     | b     | 1<br>NOTE: Main idea is more / excessive water / water is lost for such a leaf in a desert. If child can show that in her answer award 1 mark.<br>• There will be excessive water lost when X is opened and the plant will wither and die. [1]<br>• The leaves might allow excessive loss of water and the plant without water that is rarely found in the desert. [1]<br>• X allows water vapour to escape. Since desert has limited water, plant might not be able to take in enough water. The limited amount of water plants take in will escape through X so plant will eventually die due to lack of water. [1]<br>• Desert is very hot and thus plants with such leaves will die due to loss of too much water. [1]<br>• Desert is dry, the roots cannot absorb that much water, plant loses too much water so it dies. [1]  | The concept of plants losing more water than they take in   |

|     |   |  |        |   |        |   |   |   |   |     |  |  |        |  |        |  |  |
|-----|---|--|--------|---|--------|---|---|---|---|-----|--|--|--------|--|--------|--|--|
|     |   | <ul style="list-style-type: none"> <li>Plants lose a lot of water as leaves are big. [0.5]</li> <li>Plant would die as it lack water due to it letting out a lot of water vapour through the stomata to cool itself. [0.5]</li> <li>X allows water vapour to escape, there is little water in the desert so plant dies due to lack of water [0.5]</li> <li>X releases water, if it keeps opening, it will keep losing water as water evaporates faster in the desert [0.5]</li> <li>In the desert, X would close up so that plants will not lose too much water. Since the stomatas are closed up, plant cannot respire / photosynthesise thus the plant cannot survive. [0]</li> <li>X opens, plant loses water to surroundings leaving plant with little water. [0]-not clear</li> <li>Transpiration will occur through the stomata. With the water loss, plant will die due to lack of water and life in the desert.</li> <li>Warm in desert so plants will lose a lot of water through X. [0]-not complete</li> </ul>  |        |   |        |   |   |   |   |     |  |  |        |  |        |  |  |
| 32  | 2 | <table border="1" data-bbox="379 864 911 958"> <tr> <td></td> <td></td> <td></td> <td style="background-color: black;"></td> <td>B</td> <td>C</td> <td>C</td> </tr> <tr> <td>red</td> <td></td> <td></td> <td>purple</td> <td></td> <td>yellow</td> <td></td> </tr> </table> <p><b>Explanation</b></p> <ul style="list-style-type: none"> <li>Both the animals and the plant in set-up C <b>respired</b> [½], releasing <b>carbon dioxide more than</b> the animals in set-up B [½].</li> </ul> <p><b>OR</b></p> <ul style="list-style-type: none"> <li><b>Only the animals</b> in set-up B <b>respired</b> [½], releasing <b>carbon dioxide less than</b> both the animals and plant in set-up C [½].</li> </ul> <p>Dependent question. The position of "B" and "C" will decide if the child gets mark for the explanation. (If the explanation is correct)<br/> <b>Main Idea:</b> Child must explain why C has MORE carbon dioxide than B.</p> <p><i>Special considerations</i></p> <ul style="list-style-type: none"> <li>DEFINITELY "0" for the whole question when "C" is placed before "B"<br/>Eg : A,C,B or C,A,B</li> <li>READ the explanation when child writes "B,A,C". child will not get marks for labelling but will get marks for explanation if explanation is correct or partially correct.</li> </ul> |        |   |        |   | B | C | C | red |  |  | purple |  | yellow |  | <p><b>NO partial marks</b></p> <p><b>Mark holistically</b></p> <p>2 possible answers but C must be nearer to yellow</p> <p>-[½] for wrong spelling of words in bold</p> <p><b>MUST</b></p> <ul style="list-style-type: none"> <li>state the difference and show comparison</li> <li>name the process and gas involved</li> </ul> |
|     |   |  |        | B | C      | C |   |   |   |     |  |  |        |  |        |  |  |
| red |   |  | purple |   | yellow |   |   |   |   |     |  |  |        |  |        |  |  |

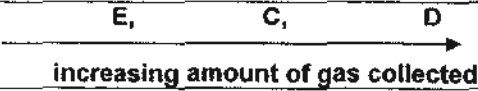
| No. | Marks | Suggested answers  | Remarks   |
|-----|-------|--|---|
| 33  | a     | 1<br>Oxygen [1m]<br>Carbon Dioxide [1m]<br>Carbon Dioxide and Oxygen [1m]<br>Oxygen and water vapour [1m]  | -[½] for wrong spelling   |
|     | b     | 1<br>Number of water plants in set-up B is more than number of water plants in set-up A [1m]<br>There are 3 water plants in set-up B and 1 water plant in set-up A [1m]<br>There are more leaves in set-up B than set-up A [1m]<br>There are more plants in set-up B than set-up A which gives out more <b>carbon dioxide</b> [0m]<br>There are more water plants in <b>set-up 2</b> [0m]<br>The number of plants [0m]<br>The higher the number of water plants, the greater the amount of gas collected [0m]  | -[½] for wrong spelling of words in bold  |
|     | c     | 1<br>   | NO partial marks  |
| 34  | a     | 1<br>The leaves gave out <b>water vapour</b> [1/2m] which condensed as water droplets [1/2m]<br>The <b>water vapour in the air that was in the plastic bag</b> [1/2m] condensed as water droplets [1/2m]<br>(must state clearly where the water vapour came from)<br>The water vapour [0m] condensed as water droplets [1/2m]<br>When plants respire, it gave out <b>water vapour</b> [1/2m] which touched the cool surface of the plastic bag and <b>condensed</b> into water droplets [1/2m]<br>Water (dew) from the plant evaporated into <b>water vapour</b> [1/2m]<br>It/water droplets/water came from the leaves/stomata [0m]<br>Water droplets came from water vapour in the air the plants <b>breathe out</b> during respiration [0m]<br>(should be <b>gives out</b> )<br>When respiring, plants take in oxygen and give out carbon dioxide in the form of water vapour [0m]<br>Roots of the plant take in water so when there was gaseous exchange, the <b>hot</b> water vapour evaporated [0m] (should be <b>warm</b> water vapour) | -[½] for wrong spelling of words in bold<br><br><b>MUST</b> state clearly where the water vapour came from  |
|     | b     | 3<br>Award 1 mark if pupils only draw a balance (as stated in the question) without objects. However, it will be assumed that the plant is on the left side and X is on the right side.<br><br><u>Drawing where plant is lighter</u><br>The plant took in water [1m] and gives out water vapour through its stomata [1m]<br>Accept photosynthesis as the cause of reduction of water level<br>- Roots had take in water [1m] for photosynthesis<br>Reject photosynthesis as the effect of reduction of water level without stating roots absorb water<br>- Plants uses some water while going through photosynthesis [0m]<br><br><u>Drawing where plant is heavier</u><br>Plants photosynthesise / make food [1m] and grow taller /  | NO partial marks<br><br><b>Mark holistically</b><br><br>Do <b>NOT</b> penalise for<br>▪ inaccurate drawing of the plant<br><br>Check that the<br>▪ mass X is correctly indicated<br>▪ the tilt is clearly shown |

have more leaves [1/2m]

Note: For pupils who wrote that plant is heavier, teacher to explain that even though it is a wrong concept, partial marks are still awarded as it was not taught in class that the lost of water mass is greater than gain in plant mass.

Plants photosynthesized and produced more food [0m]  
(Nothing was introduced to induce the plant to make more food)

Water is being absorbed by the plant [0m]  
(The plant absorbing water does not make it heavier as mass of water in the set-up is still the same)

Drawing and explanation contradicts [0m]

Drawing shows that plant is heavier but explanation states that it should be lighter due to water being absorbed by the plant.

[1] correct drawing

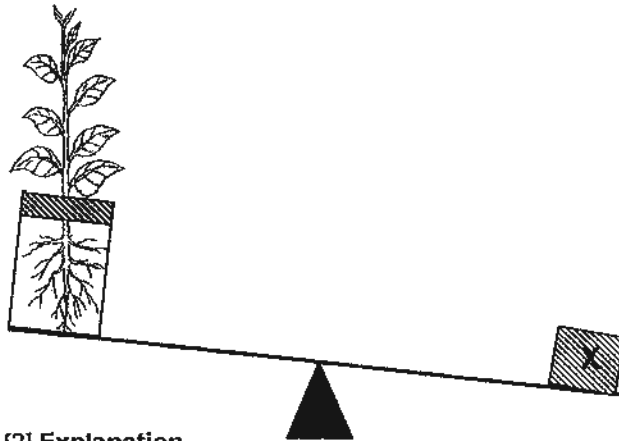

[2] Explanation

The plant took in water [ $\frac{1}{2}$ ] from the container.  
The amount of water in the container decreased [ $\frac{1}{2}$ ],  
so mass of water decreased [ $\frac{1}{2}$ ].

The mass of both plant and water in container became lighter  
than mass of X [ $\frac{1}{2}$ ] [which remained unchanged].

Do **NOT** accept:  
The weights became heavier.  
(Mass of weights remained unchanged)



|    |   |   | <p>(No condensation in the answer -1m only )<br/> The water from the hot soup evaporated and formed water vapour which came into contact with the underside of the glass lid to form water droplets.<br/> (no mentioning of the process of condensation.<br/> "formed on the underside..." does not equate to condensation.<br/> Therefore, no marks awarded for "glass lid")</p> <p><b>Zero mark</b><br/> eg.<br/> Soup condenses ....<br/> (Soup cannot condense ...do not need to consider the rest of the answer)</p> <p>eg.<br/> Steam evaporates<br/> Water vapour from the soup evaporated....<br/> concept error: water vapour/steam cannot evaporate...do not need to consider the rest of the answer)</p> |  |   |   |  |   |   |   |     |  |   |   |     |  |
|----|---|---|---|--|---|---|--|---|---|---|-----|--|---|---|-----|--|
| 36 | a | 1   | <ul style="list-style-type: none"> <li>iron ring and wooden disc</li> </ul>   | <b>No partial mark</b>                   |   |   |  |   |   |   |     |  |   |   |     |  |
|    | b | 1   | <p>Award 1m<br/> Light travels in</p> <ul style="list-style-type: none"> <li>a straight line</li> <li>straight lines</li> </ul> <p>Light cannot go through opaque object<br/> Light cannot go through metal and wood<br/> Light can be blocked by opaque object.</p> <p>[0] Do <b>NOT</b> accept:<br/> Light can be reflected. (<b>NOT</b> shown in this experiment)</p> <p>When light shines on opaque object, shadow is formed<br/> (No mark awarded as answer is explaining the formation of shadow)</p> <p>Opaque object blocks light<br/> (No mark awarded as answer is emphasising on the property of opaque object)</p>  | -[½] for wrong spelling of words in bold |   |   |  |   |   |   |     |  |   |   |     |  |
| 37 | a | 2   | <table border="1"> <thead> <tr> <th>X</th> <th>Y</th> <th>Z</th> <th></th> </tr> </thead> <tbody> <tr> <td>√</td> <td>√</td> <td>√</td> <td>[1]</td> </tr> <tr> <td></td> <td>√</td> <td>√</td> <td>[1]</td> </tr> </tbody> </table>  | X  | Y | Z |  | √ | √ | √ | [1] |  | √ | √ | [1] | <b>NO</b> partial marks for each set of answers (i) and (ii) |
|    | X | Y   | Z   |  |   |   |  |   |   |   |     |  |   |   |     |  |
| √  | √ | √   | [1]   |  |   |   |  |   |   |   |     |  |   |   |     |  |
|    | √ | √   | [1]   |  |   |   |  |   |   |   |     |  |   |   |     |  |
| b  | 1 | <p>Material of C</p> <ul style="list-style-type: none"> <li>was a <b>non-conductor</b> of electricity</li> <li>could not <b>conduct electricity</b></li> <li>did not allow <b>electricity</b> to pass through it</li> <li>was an <b>insulator</b> of electricity</li> </ul> | -[½] for wrong spelling of words in bold  |  |   |   |  |   |   |   |     |  |   |   |     |  |

|  |  |   |  |
|--|--|---|--|
|  |  | [0] Do <b>NOT</b> accept:<br>Material of C was a <b>poor conductor of electricity</b> . |  |
|--|--|---|--|

| No. | Marks | Suggested answers  | Remarks  |
|-----|-------|--|--|
| 38  | a     | 1<br><u>Answer</u><br>Rod B<br><br><u>Explanation</u><br>Two batteries <u>connected in series</u> in Q [ $\frac{1}{2}$ ]<br>produced more <u>electrical energy</u> [than a battery in P] [ $\frac{1}{2}$ ].  | <b>NO partial marks</b><br><br><b>Mark holistically</b><br><br><b>MUST</b> show a comparison between both circuits P and Q.  |
|     | b     | 1<br>It swung towards iron rod<br><ul style="list-style-type: none"> <li>▪ in Q</li> <li>▪ B</li> </ul> <b>OR</b><br>It was attracted to the iron rod<br><ul style="list-style-type: none"> <li>▪ in Q</li> <li>▪ B</li> </ul>   |  |
|     | c     | 1<br>It would swing<br><ul style="list-style-type: none"> <li>▪ towards <u>iron rod in circuit P</u></li> <li>▪ towards <u>iron rod A</u></li> <li>▪ away from <u>iron rod in circuit Q</u></li> <li>▪ away from <u>iron rod B</u></li> </ul>  |  |
| 39  | a     | 2<br><p><b>Magnetic force</b> can pass through</p> <ul style="list-style-type: none"> <li>▪ non-magnetic materials/objects</li> <li>▪ metals which are non-magnetic</li> <li>▪ iron and steel</li> </ul> <p style="text-align: right;">} [<math>\frac{1}{2}</math>]</p> <p>but it cannot pass through</p> <ul style="list-style-type: none"> <li>▪ <b>magnetic materials/objects</b></li> <li>▪ <b>metals which are magnetic</b></li> <li>▪ <b>copper and aluminium</b></li> </ul> <p style="text-align: right;">} [<math>\frac{1}{2}</math>]</p> <p style="text-align: center;"><b>OR</b></p> <p>Magnetic force can <b>only</b> [<math>\frac{1}{2}</math>] pass through <u>non-magnetic materials/objects</u> [<math>\frac{1}{2}</math>].</p> | -[ $\frac{1}{2}$ ] for wrong spelling of words in bold<br><br><b>NOT acceptable:</b><br><ul style="list-style-type: none"> <li>▪ Magnetic force can pass through non-metals. (experiment showed materials: copper, aluminium which are metals)</li> <li>▪ Magnetic <i>current</i></li> </ul> |
|     | b     | 1<br>Accept any material / non-metal which does not allow magnetism to pass through:<br><ul style="list-style-type: none"> <li>▪ plastics/ plastic</li> <li>▪ wood</li> <li>▪ carbon</li> <li>▪ rubber</li> <li>▪ glass</li> <li>▪ silver</li> <li>▪ tungsten</li> <li>▪ cloth</li> <li>▪ paper</li> </ul> <p style="text-align: right;">} material, <b>NOT object</b></p>   | -[ $\frac{1}{2}$ ] for wrong spelling of material<br><br><b>NOT acceptable:</b><br><ul style="list-style-type: none"> <li>▪ nickel</li> <li>▪ cobalt</li> </ul> Both metals are magnetic materials.  |

- END OF PAPER -