

METHODIST GIRLS' SCHOOL

Founded in 1887



SCIENCE PRIMARY 6 MID-YEAR EXAMINATION 2010

BOOKLET A

Total Time : 1 hour 45 minutes

INSTRUCTIONS TO CANDIDATES

Do not open the booklet until you are told to do so.
Follow all instructions carefully.
Answer all questions.

Name: _____ ()

Class: Primary 6. _____

Date : 10 May 2010

This booklet consists of 20 printed pages.

Section A (30 x 2 marks)

For each question from 1 to 30, four options are given. One of them is the correct answer. Make your choice (1, 2, 3 or 4). Shade the correct oval (1, 2, 3 or 4) on the Optical Answer Sheet (OAS).

1. Study the flow chart below.

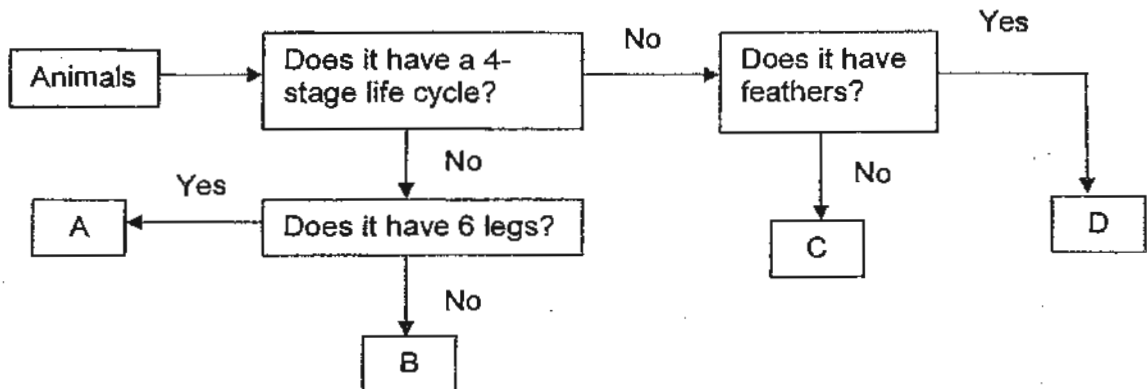

Which one of the following options represents A, B, C and D above?

	A	B	C	D
(1)	Grasshopper	Hen	Mosquito	Human
(2)	Dragonfly	Whale	Cockroach	Duck
(3)	Cockroach	Horse	Eagle	Beetle
(4)	Spider	Sparrow	Butterfly	Swallow

2. Study the classification table below.

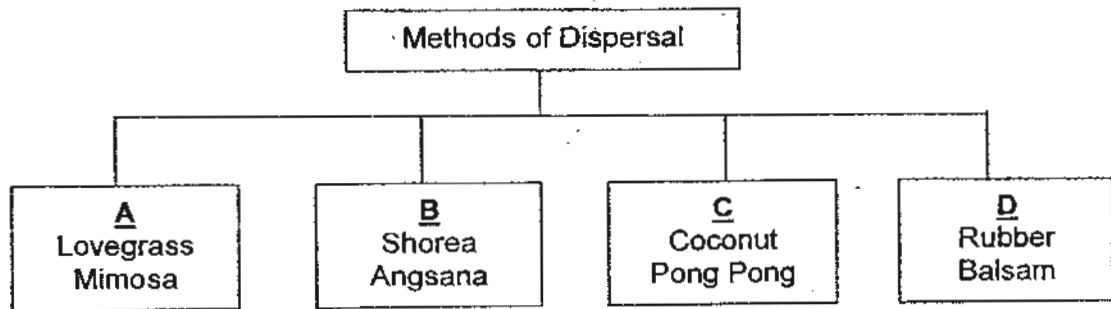

Which of the following classification for method of dispersal is correct?

	A	B	C	D
(1)	Wind	Animal	Splitting	Water
(2)	Animal	Splitting	Wind	Water
(3)	Animal	Wind	Water	Splitting
(4)	Wind	Animal	Water	Splitting

3. The table shows the eye colours that children inherited from their parents within the community. The eye colours of the parents are shown at the top of the table.

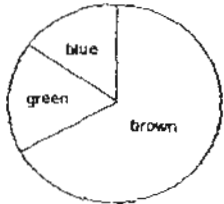
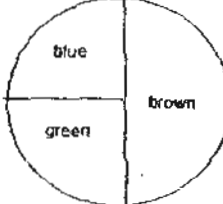
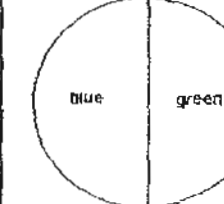
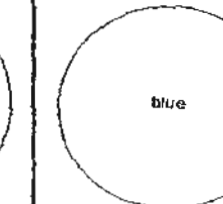
Eye colour of parents	Mother – brown Father – brown	Mother – brown Father – blue	Mother – green Father – green	Mother – blue Father – blue
Eye colour of children (%)				

Which statement is correct about the inheritance of eye colour by these children?

- (1) If both parents have blue eyes, they will have no brown-eyed children.
 - (2) If the mother has brown eyes, then all her children will have brown eyes.
 - (3) If the father has blue eyes, then at least 50% of his children will have blue eyes.
 - (4) If both parents have eyes of the same colour, than all of their children will have that same eye colour.
4. Which part of the flower produces a powdery substance which has a similar function as the human sperm?

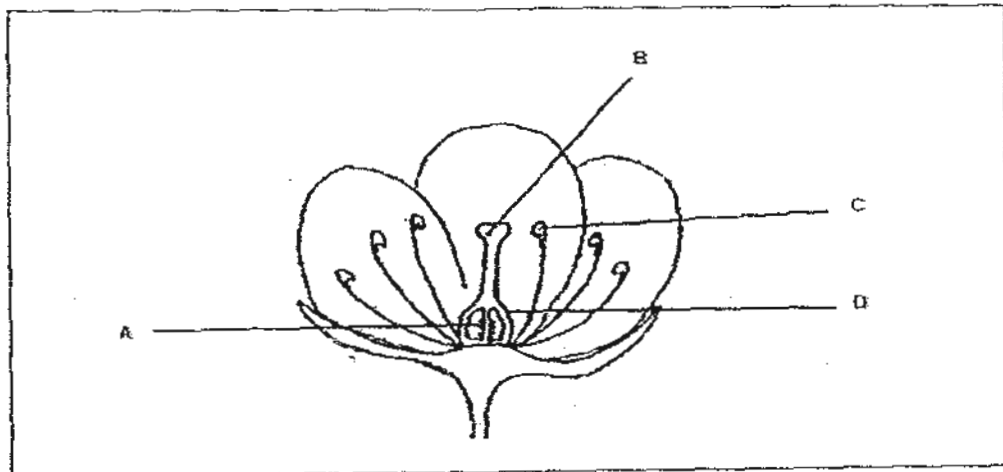

- (1) A
- (2) B
- (3) C
- (4) D

5. The diagram shows the cross-section of an air sac and a capillary in a lung.

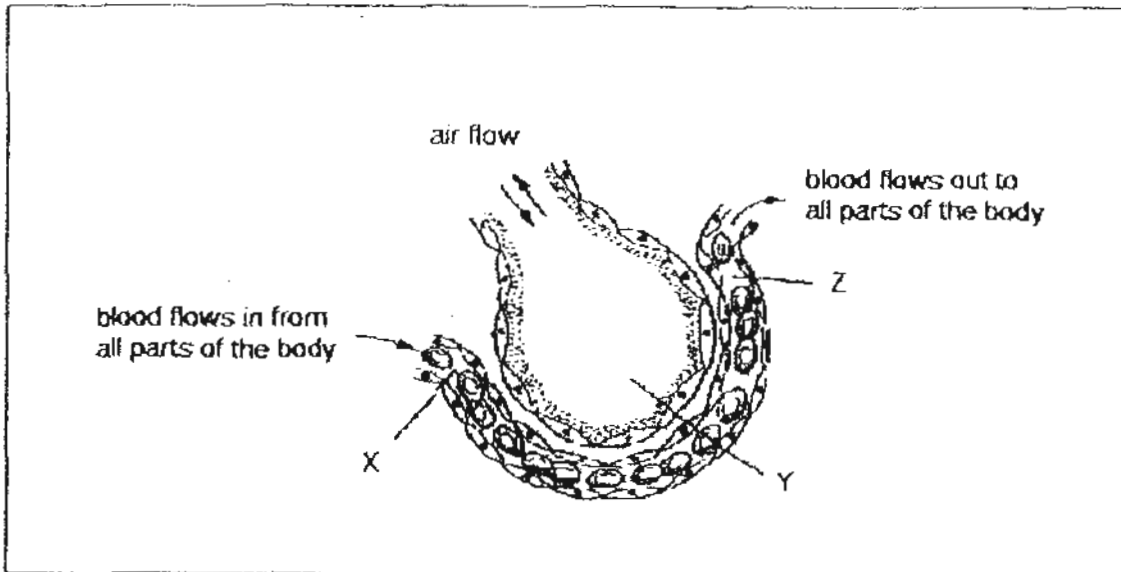

Which one of the following correctly describe the concentration of oxygen at X, Y and Z?

	X	Y	Z
(1)	high	high	low
(2)	high	low	high
(3)	low	high	high
(4)	low	high	low

- 6.

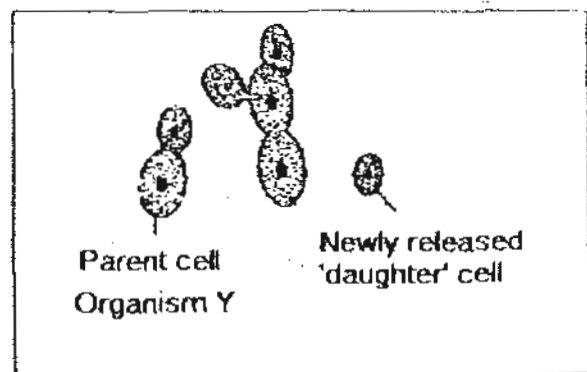
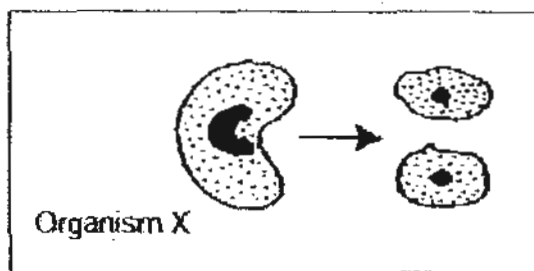

Which one of the following statements about Organisms X and Y is 

- (1) Both organisms are unicellular.
- (2) Both organisms X and Y are likely to be fungi.
- (3) Organism X is likely to be an animal while Organism Y is a type of bacteria.
- (4) Cells in both Organism X and Organism Y have to be fertilized before reproduction can take place.

7. Bala grew his plants in a small tray as shown below. He placed the pot outside in indirect sunlight and watered them every day.

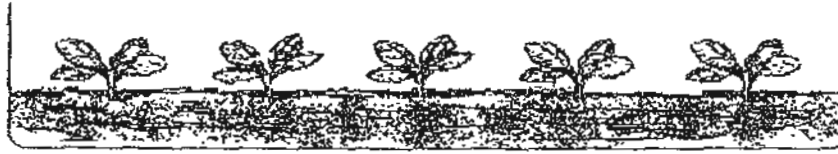

After a few weeks, the plants died. What is the most likely reason for this to happen?

- (1) Overcrowding.
 - (2) Not enough water.
 - (3) Not placed under sunlight.
 - (4) Infested by pest
8. There is a great variety of plants around us.

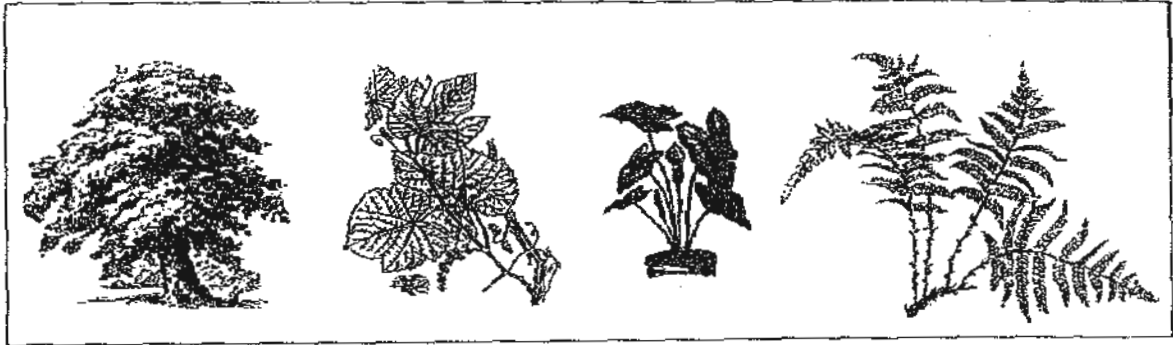

In what ways are all the plants around us similar?

- A : They can replenish the air with oxygen
- B : They are made up of cells that have cell walls.
- C : They do not move freely from one place to another by themselves.
- D : They can reproduce their own kind if pollination and fertilization take place.

- (1) A and D only
- (2) A, B and C only
- (3) B, C and D only
- (4) A, B, C and D

9. The diagram shows the circulatory system in human beings.

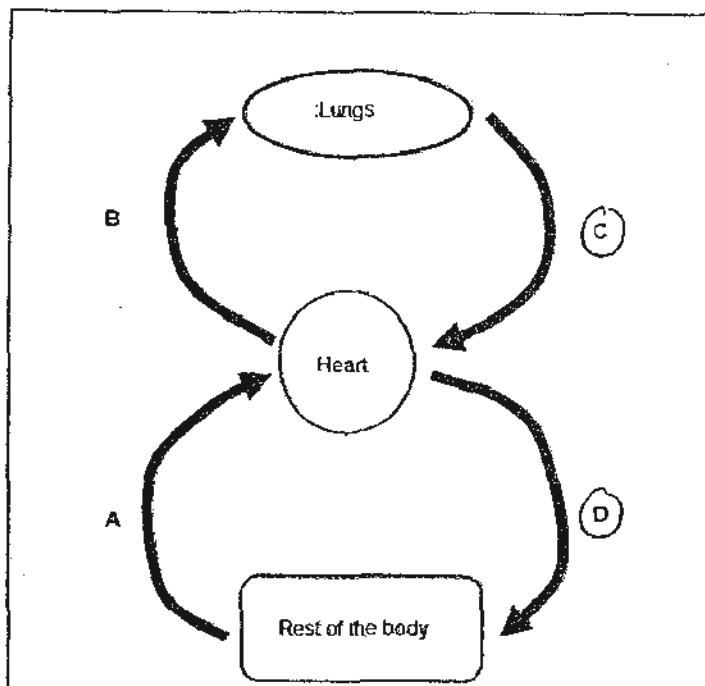

Which blood vessels contain oxygenated blood?

- (1) A and B
- (2) B and C
- (3) C and D
- (4) A and D

10. Jimmy used a data-logger to measure the amounts of carbon dioxide given off by the roots and leaves of a plant at different times of the day. Which one of the following graphs shows the results he is most likely to get?

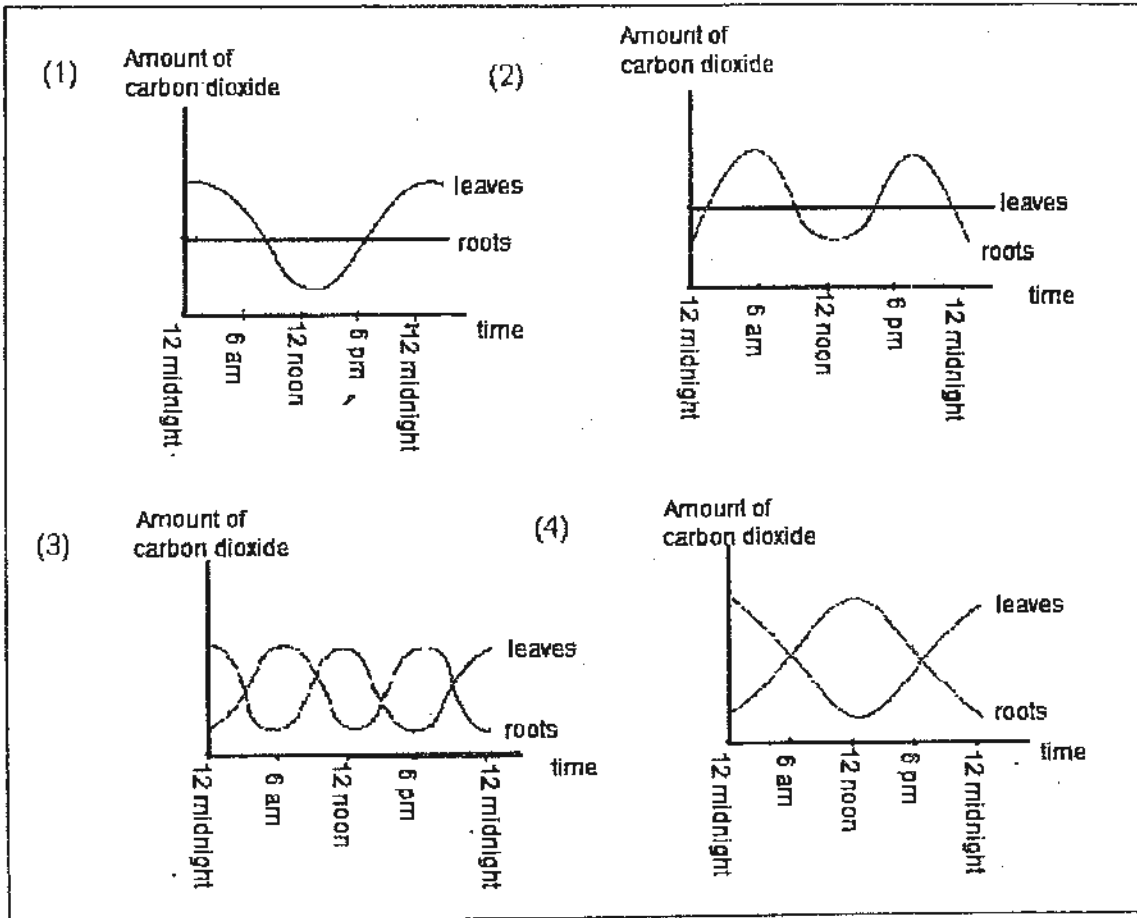

11. The diagram below shows a food web.

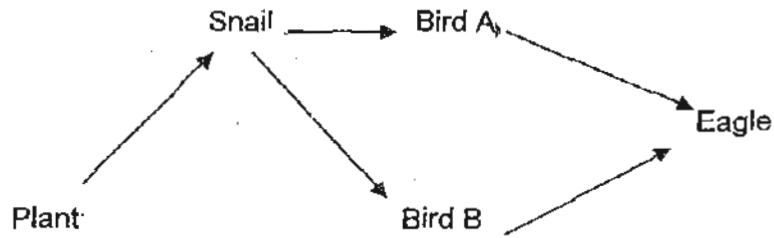

When a new organism is introduced into this food web, this organism only preys on snails. Which of the following about the number of each organism in this food web is not correct?

- (1) The number of Bird A would decrease.
 - (2) The number of Bird B would decrease.
 - (3) The number of plants would decrease.
 - (4) The number of eagles would decrease.
12. The diagram below shows a food web.

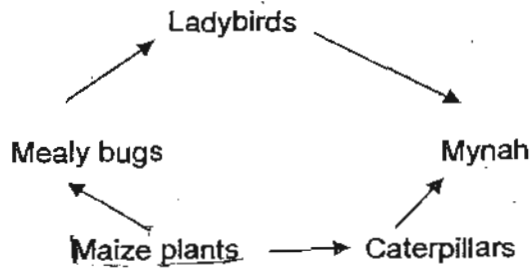

Which of the following organisms are secondary consumers?

- A : Mealy bugs
- B : Ladybirds
- C : Caterpillars
- D : Mynah

- (1) A and C only
- (2) B and C only
- (3) B and D only
- (4) A and D only

13. Some grasshoppers were kept in a container with holes. The number of grasshoppers were counted and recorded as shown in the graph below.

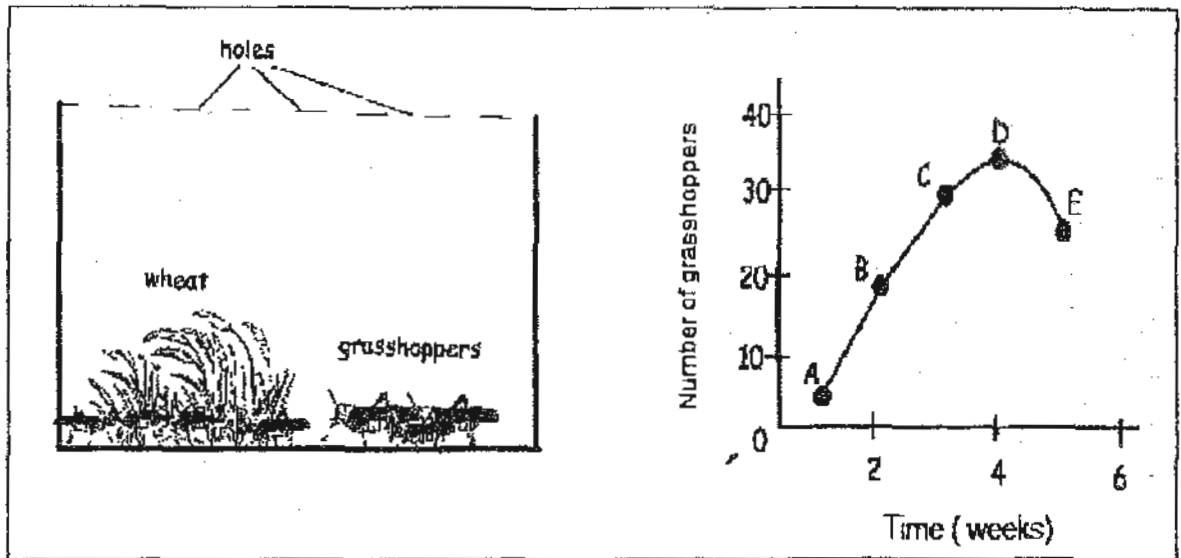

What might have happened at DE?

- A : All the wheat was eaten up.
- B : A frog was introduced to the container
- C : More wheat was added to the container.

- (1) A only
- (2) B only
- (3) A and B only
- (4) A, B and C

14. Alex and his friends counted the number of organisms that were living in the school pond. They then plotted the results in the graph shown below.

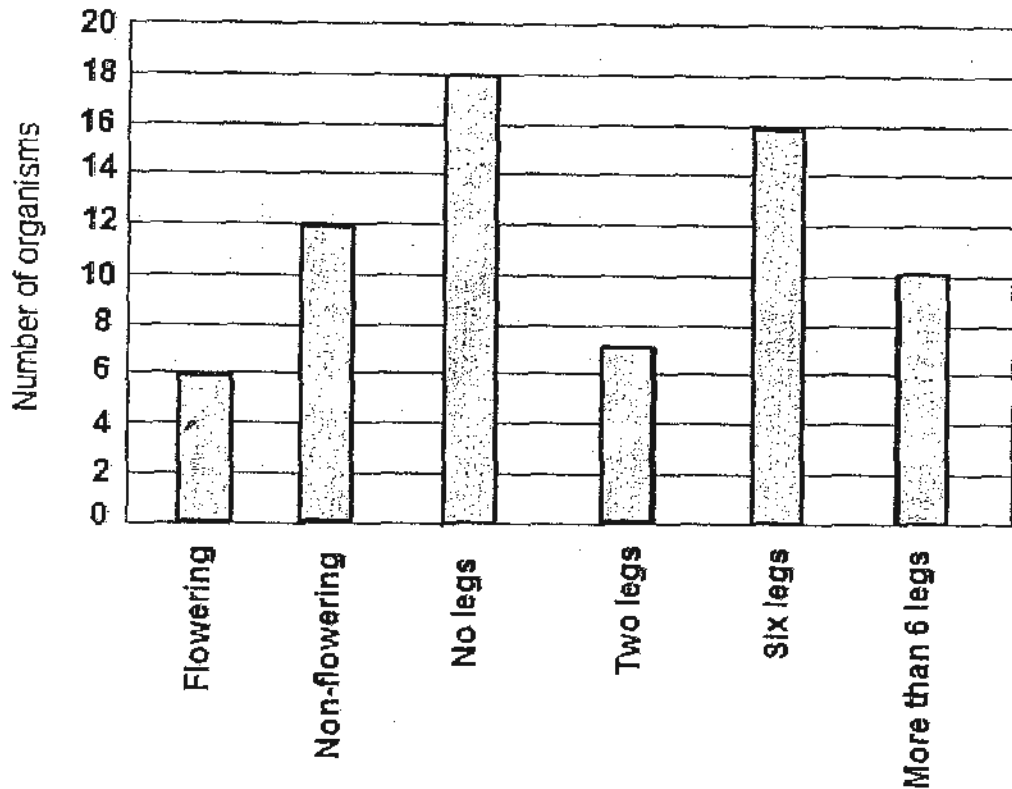

Which of the following conclusions can they make from the graph?

- A : There are 16 insects in the pond.
- B : There are 6 communities living in the pond.
- C : There are 6 populations of flowering plants in the pond.
- D : There are at least 4 populations of animals in the pond

- (1) A and B only
- (2) B and C only
- (3) A and D only
- (4) C and D only

15. Habitat A consists of three populations – fruit flies, grasshoppers and frogs. Which of the following sets of graphs correctly shows the changes in the populations of the fruit flies and grasshoppers after a population of snakes is introduced to the habitat?

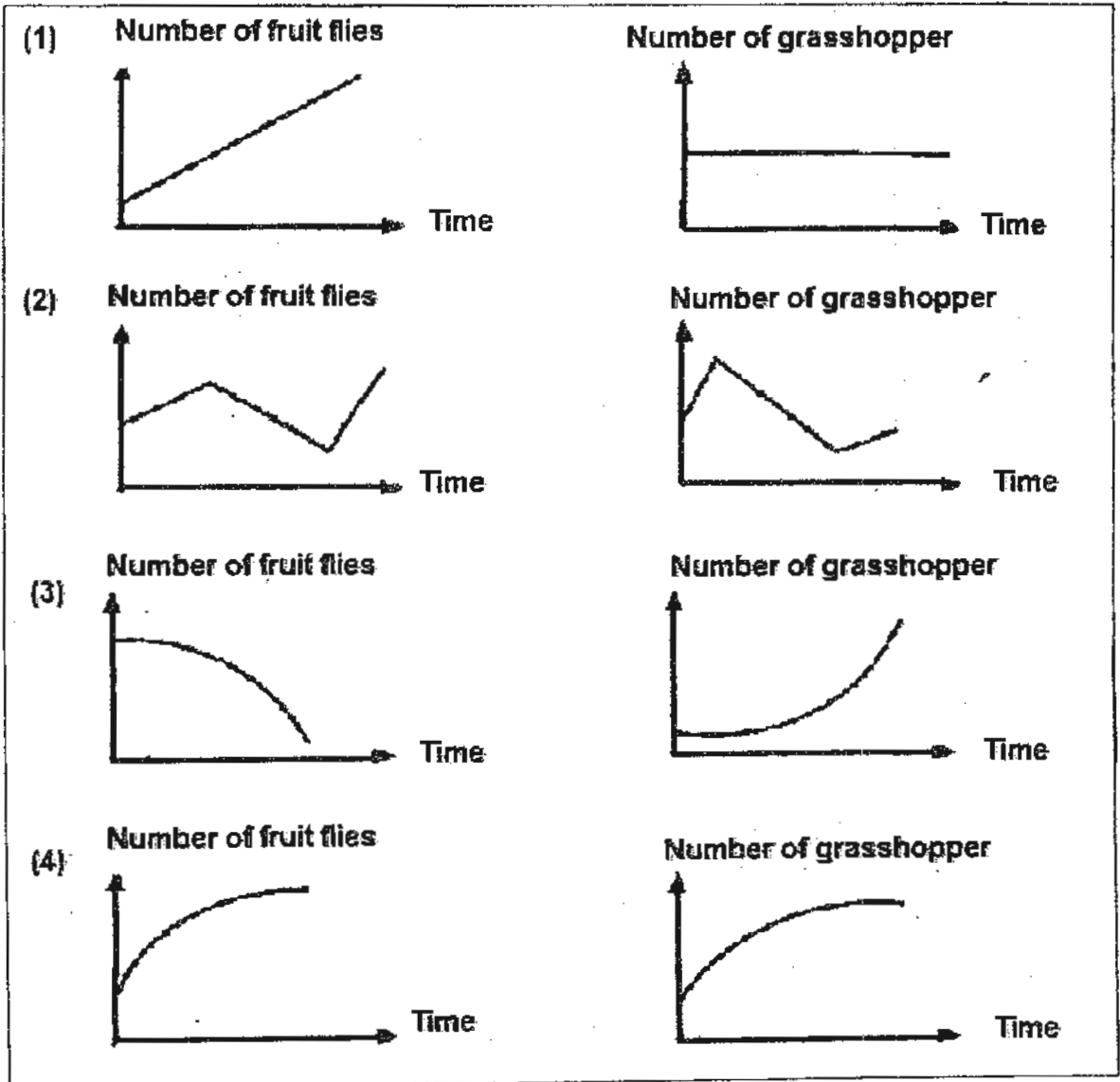

16. Keren observed the properties of an object and recorded them down in the table below.

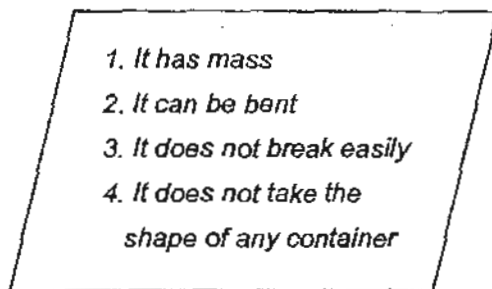

What could the object be, and what is the material that was used to make the object?

	Object	Material
(1)	Sponge	Foam
(2)	Vase	Glass
(3)	Button	Plastic
(4)	Pencil	Wood

17. 400 cm³ of air is trapped in a beaker as shown in Figure A. The beaker is then being pushed deeper into the water as shown in Figure B.

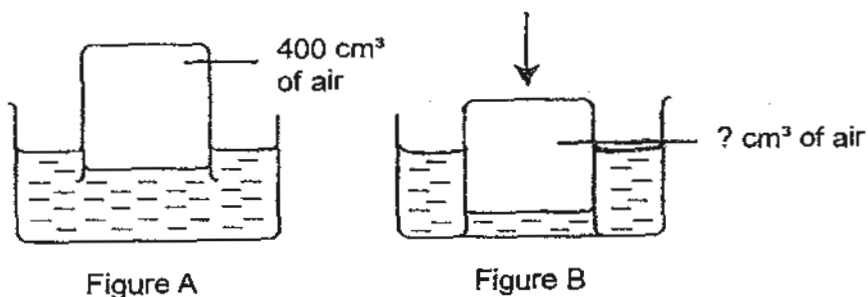

What should the ^{Likely} volume of air be in the beaker?

- (1) 0 cm³
- (2) 380 cm³
- (3) 400 cm³
- (4) 410 cm³

18. The following activities involve changes in the states of water.

X: Laundry is dried.

Y: A glass of cold drink is left on a table for some time.

Z: A tub of ice cream is taken out of the freezer.

Which of the following shows the correct processes for the change in states of water for each activity above?

Process			
	Activity X	Activity Y	Activity Z
(1)	Condensation	Evaporation	Freezing
(2)	Condensation	Evaporation	Melting
(3)	Evaporation	Condensation	Freezing
(4)	Evaporation	Condensation	Melting

19. Ginny made the model as shown below. The wires are connected to the two contact points in the middle of the foldable cards and these cards are made of material A. When the cards are folded together, the circuit is closed.

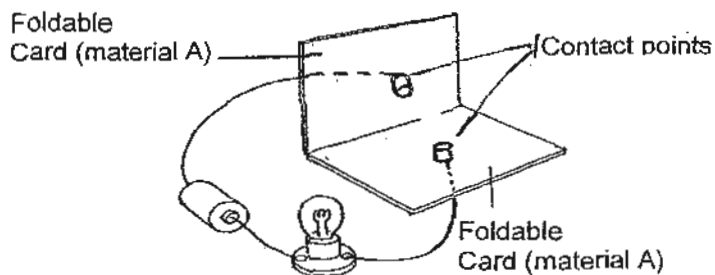

The materials used to make the cards, wires and contact points are shown below. In which of the following would the bulb not light up?

	Material A	Wire	Contact points
(1)	Iron	Copper	Plastic
(2)	Plastic	Copper	Steel
(3)	Steel	Aluminium	Copper
(4)	Aluminium	Silver	Iron

20. Five magnets with their ends marked A to J are joined together as shown.

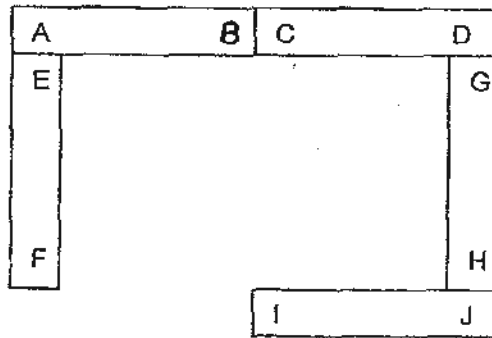

Which one of the following diagrams shows a possible arrangement of two of the magnets?

~~⊗~~

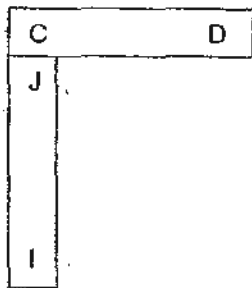

~~⊗~~

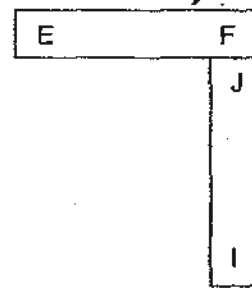

~~⊗~~

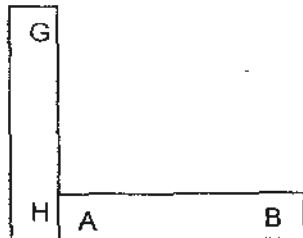

~~⊗~~

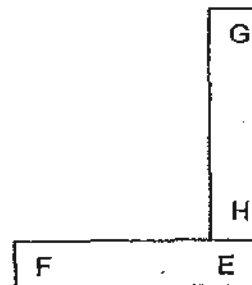

21. Li Hua wants to find out whether the mass of an object affects the amount of gravitational force it exerts. She planned to conduct her experiment by dropping various weights from different heights as shown below.

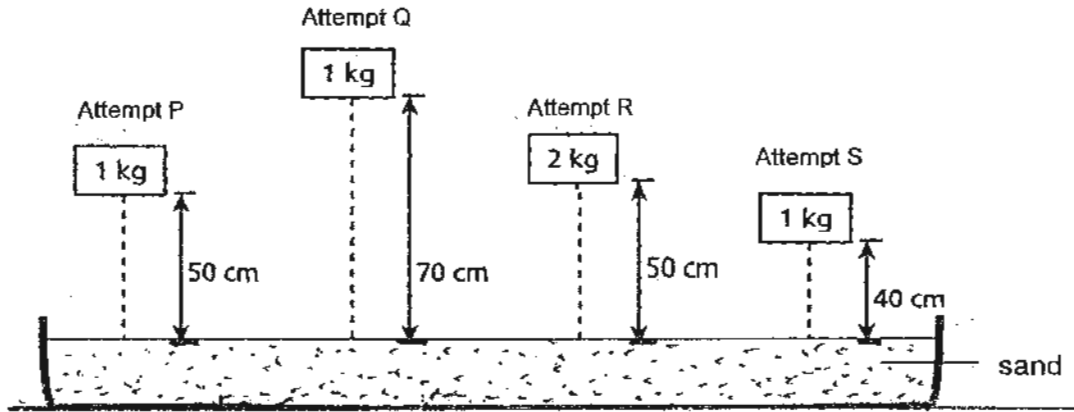

Which two attempts, P, Q, R or S, should she use in order to conduct a fair test?

- (1) P and Q
 (2) P and R
 (3) Q and R
 (4) Q and S
22. An elastic spring is stretched when a mass is hung from it. The spring extends by a constant length for every kilogram of mass hung from it. Two masses, 4kg and 6kg, are suspended on two identical springs as shown.

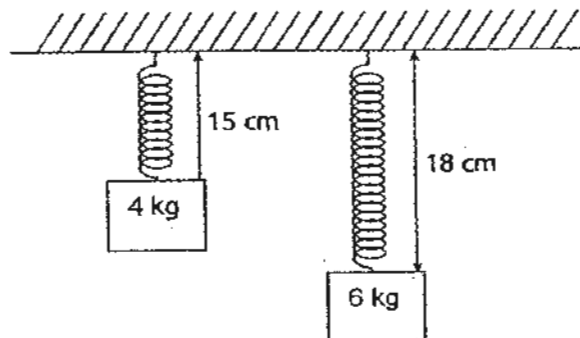

What is the original length of the spring?

- (1) 7 cm
 (2) 9 cm
 (3) 12 cm
 (4) 15 cm

23. Felix shone a torch at an object at different angles. She then drew the shadows she observed as shown below.



Which one of the following objects could Felix be shining the torch at?

(1)

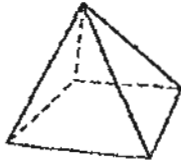

(2)

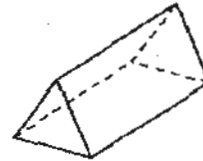

(3)

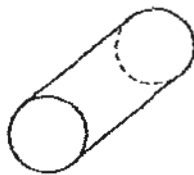

(4)



24. We are able to see an object because it is either a light source or it is able to reflect light to our eyes. This is true for what we observed in the diagram below. The arrows represent light rays.

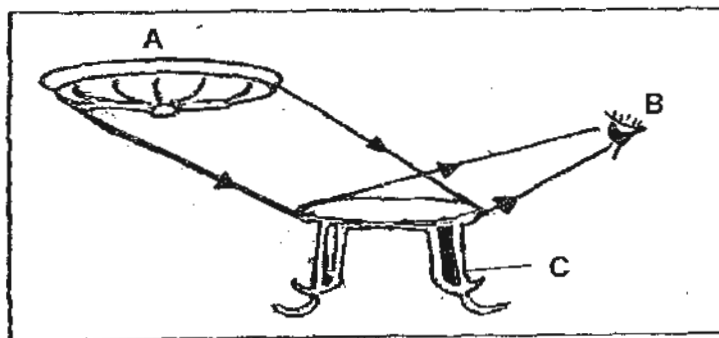

Based on the diagram, identify the light source and the object that reflects light.

	Light source	Reflects light
(1)	B	C
(2)	C	B
(3)	A	B
(4)	A	C

25. Kate was not able to open the cap of a glass jar. Then, she remembered learning about heat and friction in her recent Science lesson.

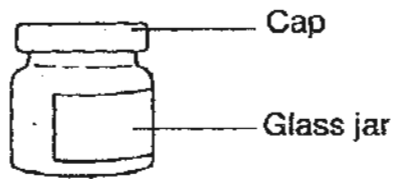

Which container should she dip the cap of the glass jar into so that she can easily open the cap in the shortest period of time?

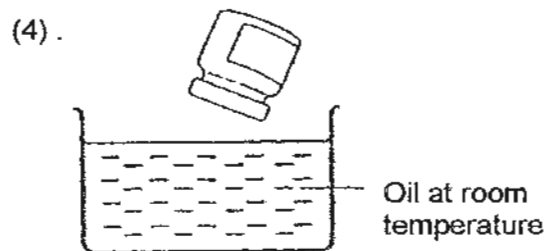
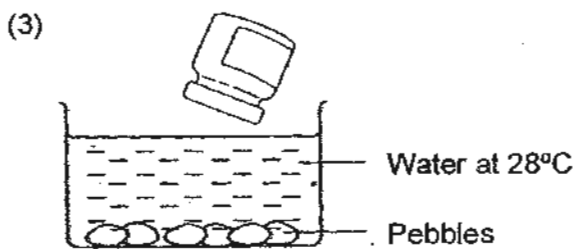
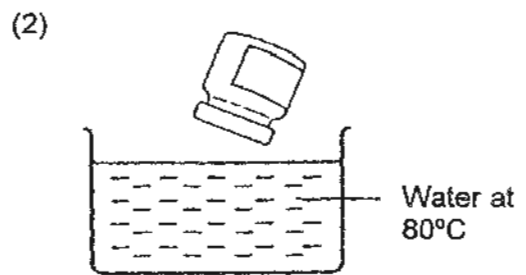
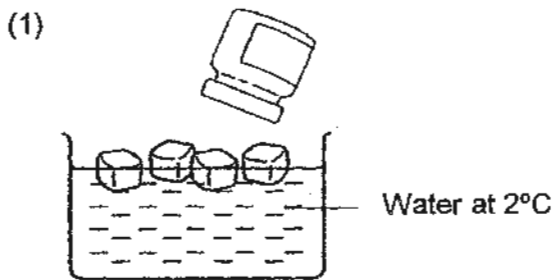

26. A group of students had 4 containers that were each made of different materials. They wanted to find out which container would best retain heat.

For each container, they carried out 2 experiments. In the first experiment, they measured the temperature of a cup of 20ml of ice water after 10 minutes. In Experiment 2, they measured the temperature of a cup of 20ml of hot water after 10 minutes. These 2 experiments were repeated for all 4 containers.

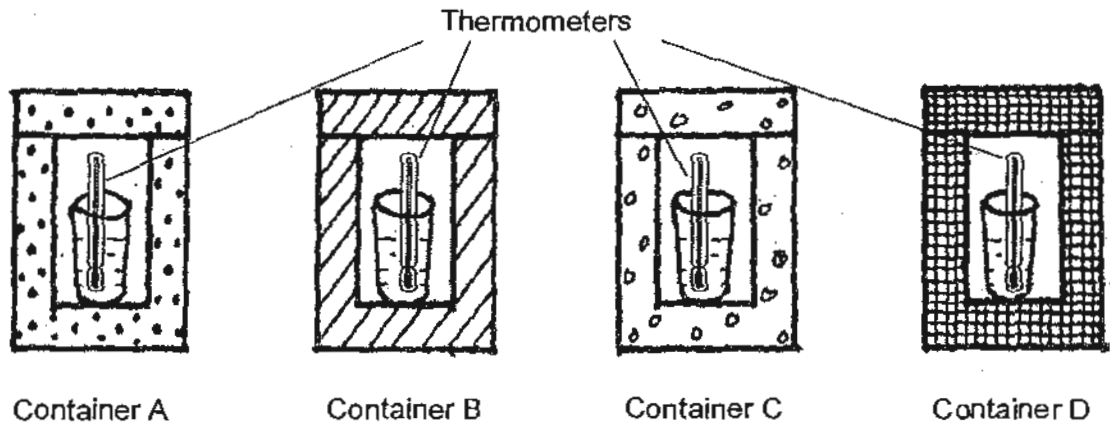

The readings of the experiments were recorded in the table below. Which container should the students select which would best meet their objective?

	Container	Experiment 1	Experiment 2
		Temperature of ice water after 10 min (°C)	Temperature of hot water after 10 min (°C)
(1)	A	6	77
(2)	B	13	60
(3)	C	3	85
(4)	D	7	68

27. Study the diagram below.

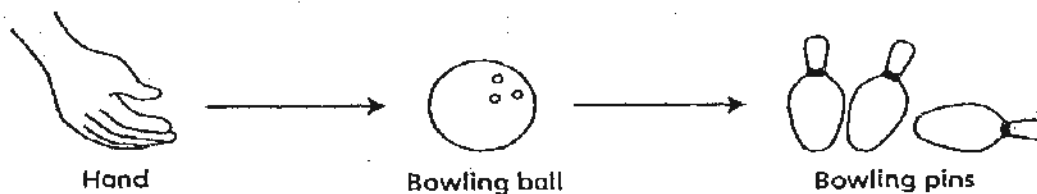

Which of the following options shows the correct conversion of energy?

(1)	heat energy of hand	→	kinetic energy of bowling ball	→	kinetic energy of bowling pins
(2)	chemical energy of hand	→	kinetic energy of bowling ball	→	sound energy of bowling pins
(3)	Gravitational potential energy of hand	→	chemical energy of bowling ball	→	kinetic energy of bowling pins
(4)	kinetic energy of hand	→	potential energy of bowling ball	→	sound energy of bowling pins

28. Vick set up an experiment to see the effect of running water on a water wheel. He drilled a hole at the bottom of a tin full of water and placed the water wheel beneath it.

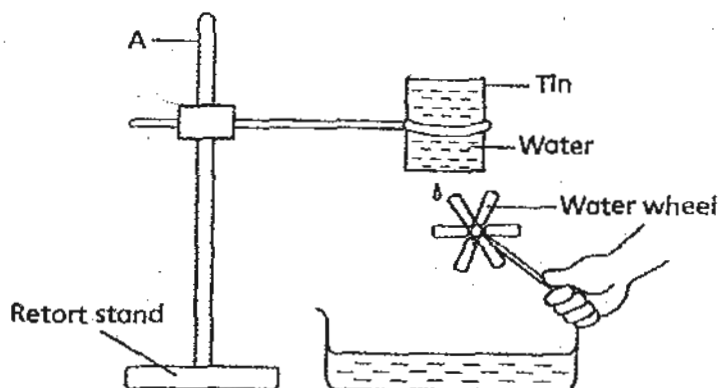

Which of the following modifications should Vick make if he wants the water wheel to spin faster?

- S: Move the water wheel down, further away from the tin.
- T: Move the tin to a height at Position A.
- U: Increase the size of the hole.
- V: Increase the size of the tin.

- (1) S and V
- (2) T and V
- (3) S and U
- (4) T and U

29. Anidah set up an experiment as shown below. She noticed that when she lit the candle, the paper spiral started to spin.

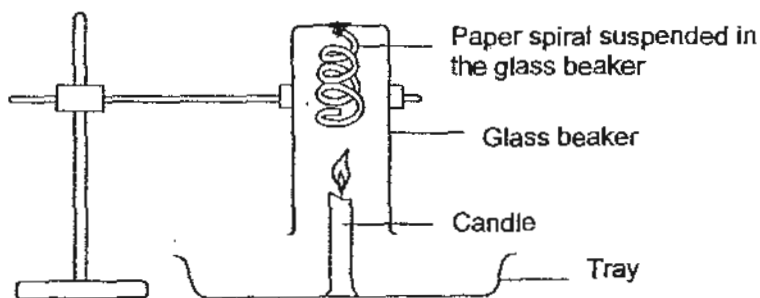

Which of the following statements best explained her observation?

- (1) The spiral expanded and started spinning.
- (2) The air in the glass beaker expanded and pushed against the glass beaker.
- (3) Kinetic energy of the moving air is converted to kinetic energy in the spiral.
- (4) Heat energy in the candle is converted directly to kinetic energy in the spiral.

30. Khan threw a basketball as shown.

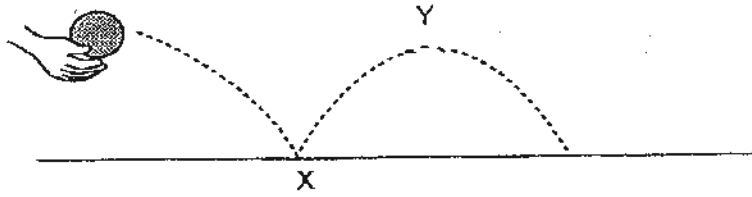

Which one of the following graphs **correctly** shows the energy conversions that occur between X and Y?

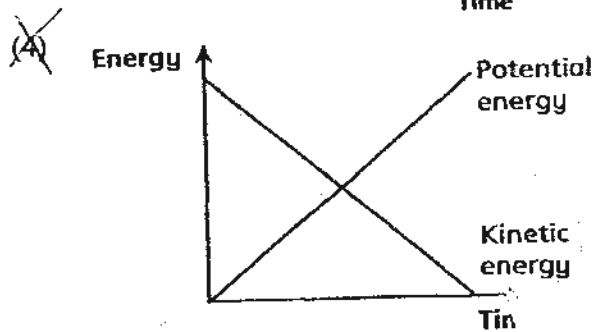
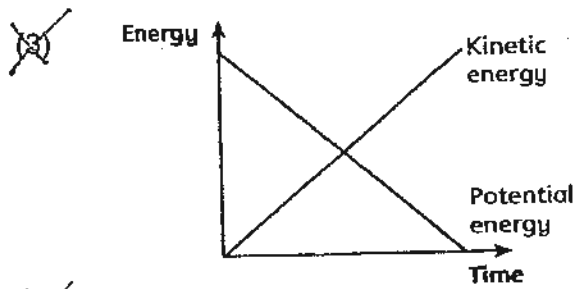
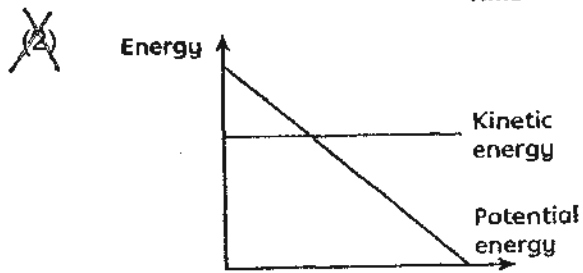
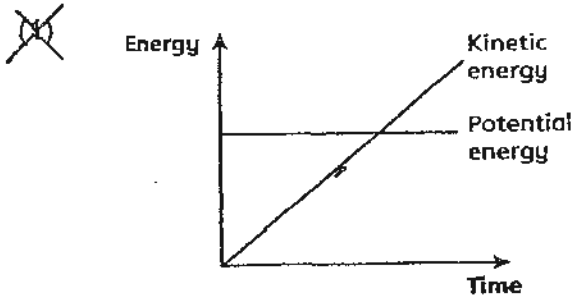

----- End of Booklet A -----

METHODIST GIRLS' SCHOOL

Founded in 1887



SCIENCE PRIMARY 6 MID-YEAR EXAMINATION 2010

BOOKLET B1

Total Time : 1 hour 45 minutes

INSTRUCTIONS TO CANDIDATES

Do not open the booklet until you are told to do so.
Follow all instructions carefully.
Answer all questions.

Name: _____ ()

Class: Primary 6. _____

Date : 10 May 2010

Section A	/60
Section B1	/20
Section B2	/20
Total	/ 100

This booklet consists of 7 printed pages.

Section B (40 marks)

For questions 31 to 44, write your answers in the spaces provided.

31. Study the chart below.

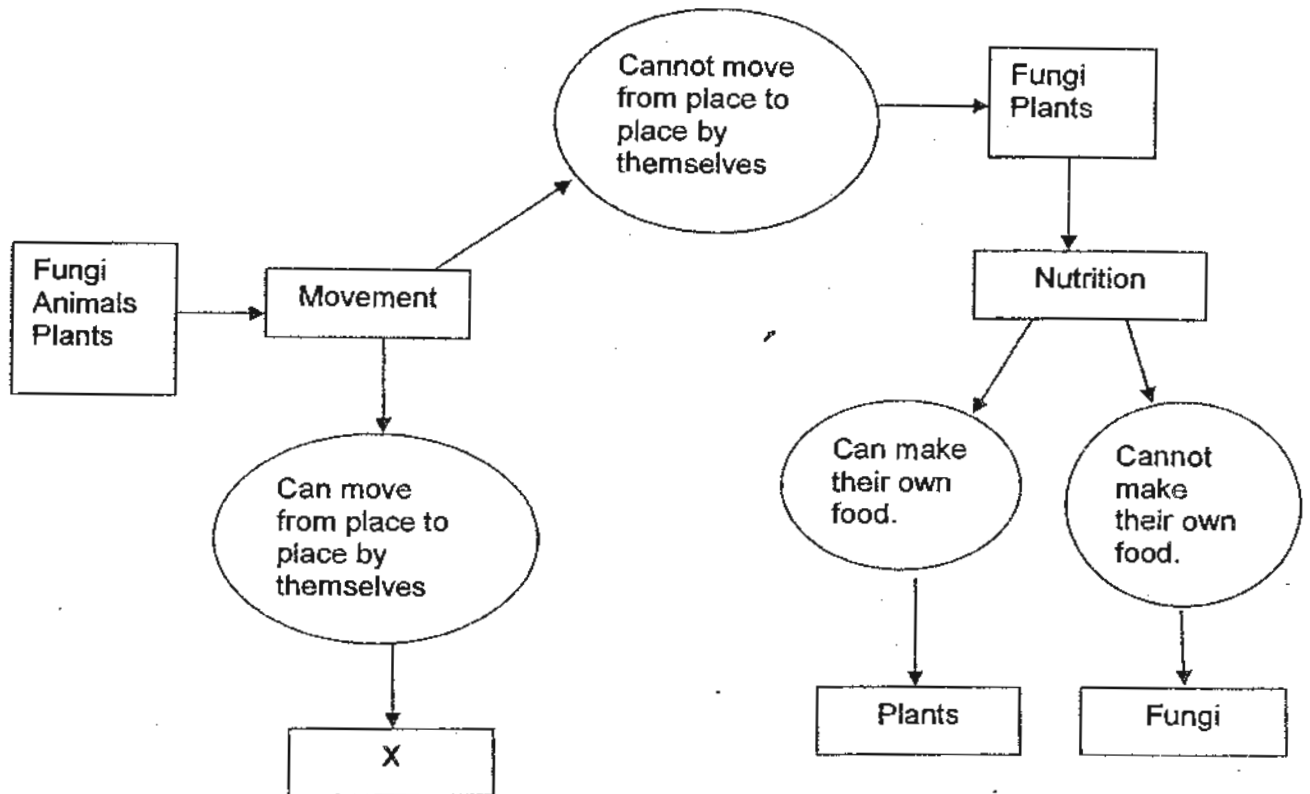

(a) What does X in the chart above represent? (1m)

(b) Based on the above chart, in what way are fungi and plants similar? (1m)

32. Study the flow chart below carefully.

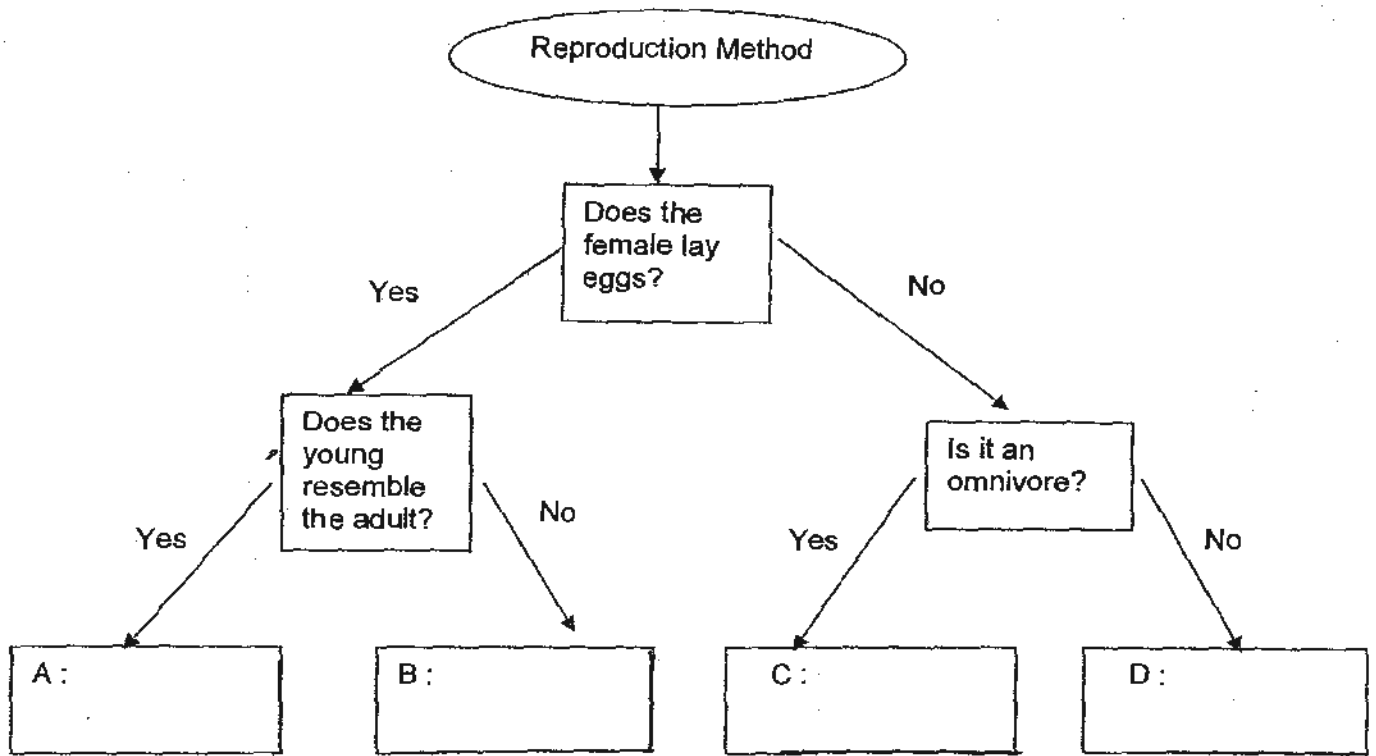

- (a) Put the following animals: lizard, zebra, man and dragonfly in the boxes above. (2m)
- (b) Name an organism that is a mammal but lays eggs. (1m)
-

33. The two pie-charts below show the percentage of animals in two Leaf-litter communities A and B. Both Leaf litter communities A and B have the same total percentage of organisms. Study the statements that follow and state whether they are true (T) or false (F) or unable to tell (U).

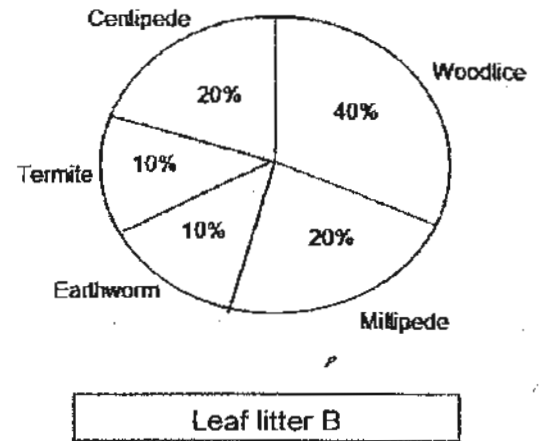
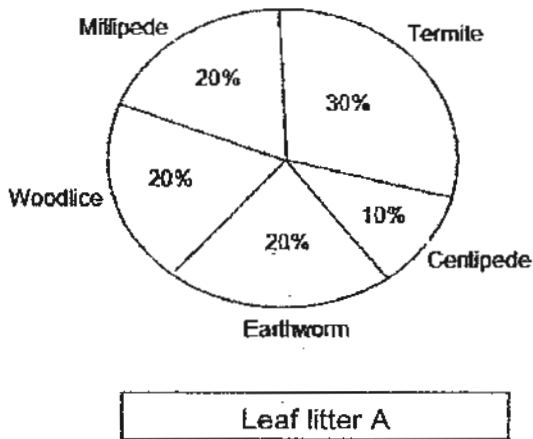

Write the letters T, F or U in the boxes.

(2m)

- (a) In Leaf litter A, there are more termites than the combined total of the other groups of animals.
- (b) The centipedes in Leaf litter A is likely to increase because of the abundance of food supply.
- (c) The number of centipedes in Leaf litter B is less than that of Leaf litter A.
- (d) Leaf litter B has a lower percentage of termites than in Leaf litter A.

34. The graph below shows Samy's pulse rate over a period of one hour.

Pulse rate / beats per minute

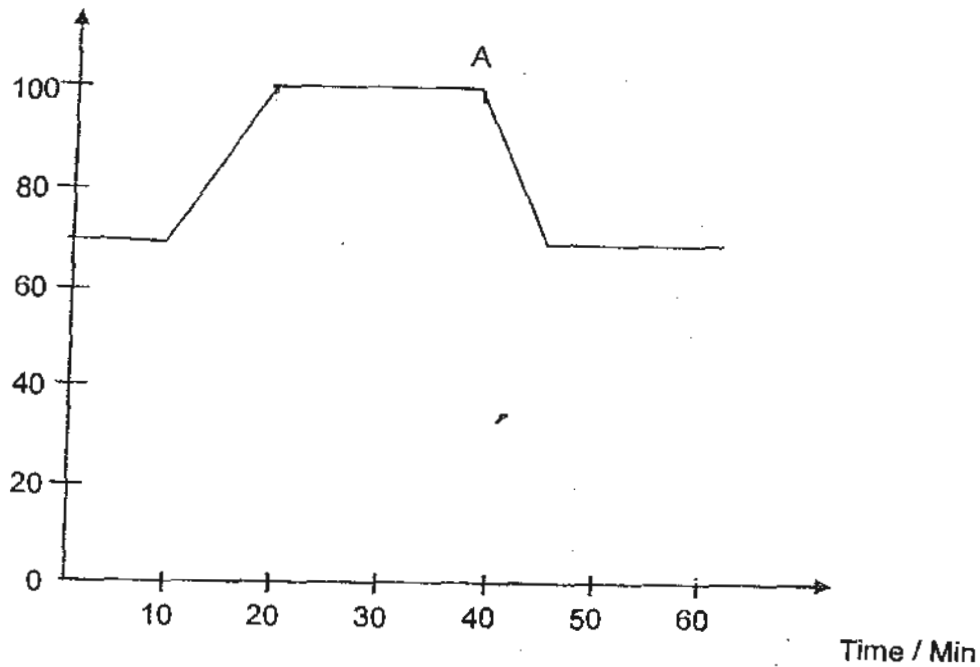

- (a) What was Samy's pulse rate when he is at rest? (1m)
-
- (b) What was Samy's maximum pulse rate and how long did it last? (1m)
-
- (c) Samy stopped running at point A. Explain why it took some time for Samy's pulse rate to return to his original reading at the start? (1m)

35. The graph below shows how the populations of two types of living things, X and Y, in a certain community change over time.

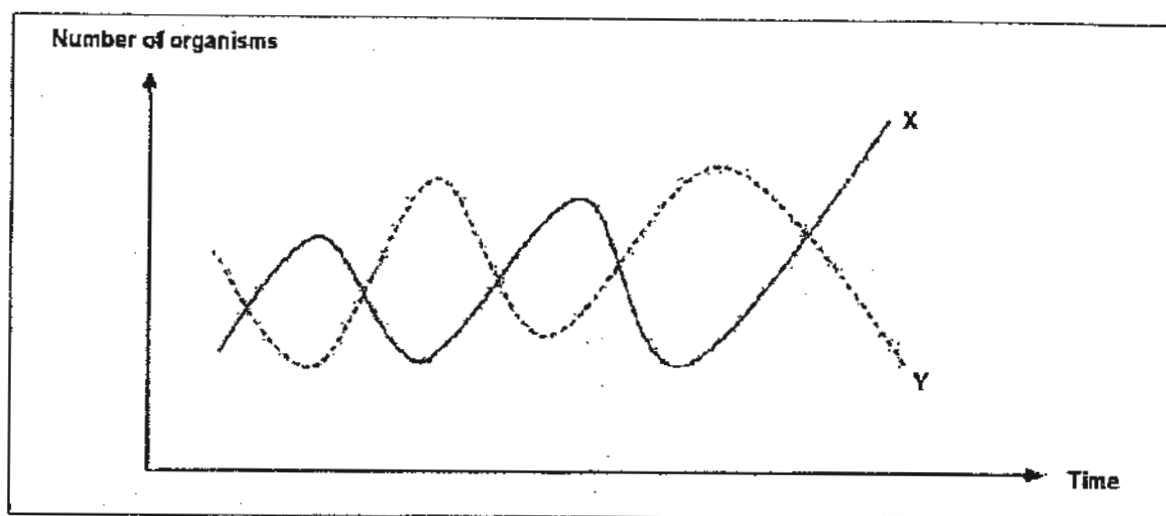

- (a) Describe how the population of X changes as the population of Y changes. (2m)

- (b) What could be the relationship between organisms X and Y? (1m)

36. The diagram shows a terrarium, which is a self-sustaining community of small plants living in a sealed glass jar.

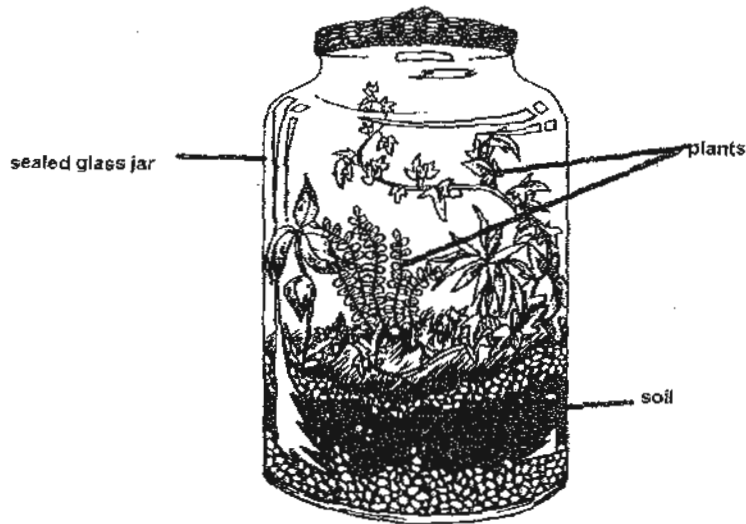

- (a) After putting the layer of soil and adding in the plants, what must be done before sealing the glass jar? (1m)

- (b) Where should the terrarium be placed to ensure healthy plant growth? (1m)

- (c) Explain in detail how the plants in the terrarium get the carbon dioxide, oxygen and water to survive. (2m)

37. Look at the diagram of the set-up below.

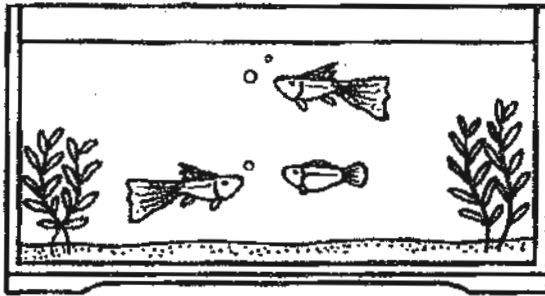

Tank A

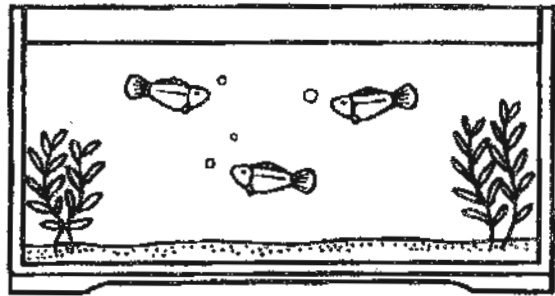

Tank B

Tank A contains both male and female guppies while Tank B contains only female guppies. All other factors were kept the same to make it a fair test. After six months, it was observed that the number of guppies in Tank A had increased while that in Tank B had decreased.

- (a) Give the most likely reason for the decrease in the number of guppies in Tank B if all other factors were kept the same for both tanks? (1m)

- (b) Name 2 factors that were kept the same to make it a fair test. (2m)

----- End of Booklet B1 -----

METHODIST GIRLS' SCHOOL

Founded in 1887



SCIENCE PRIMARY 6 MID-YEAR EXAMINATION 2010

BOOKLET B2

Total Time : 1 hour 45 minutes

INSTRUCTIONS TO CANDIDATES

Do not open the booklet until you are told to do so.
Follow all instructions carefully.
Answer all questions.

Name: _____ ()

Class: Primary 6. _____

Date : 10 May 2010

20

This booklet consists of 8 printed pages.

38. Study the flow chart carefully.

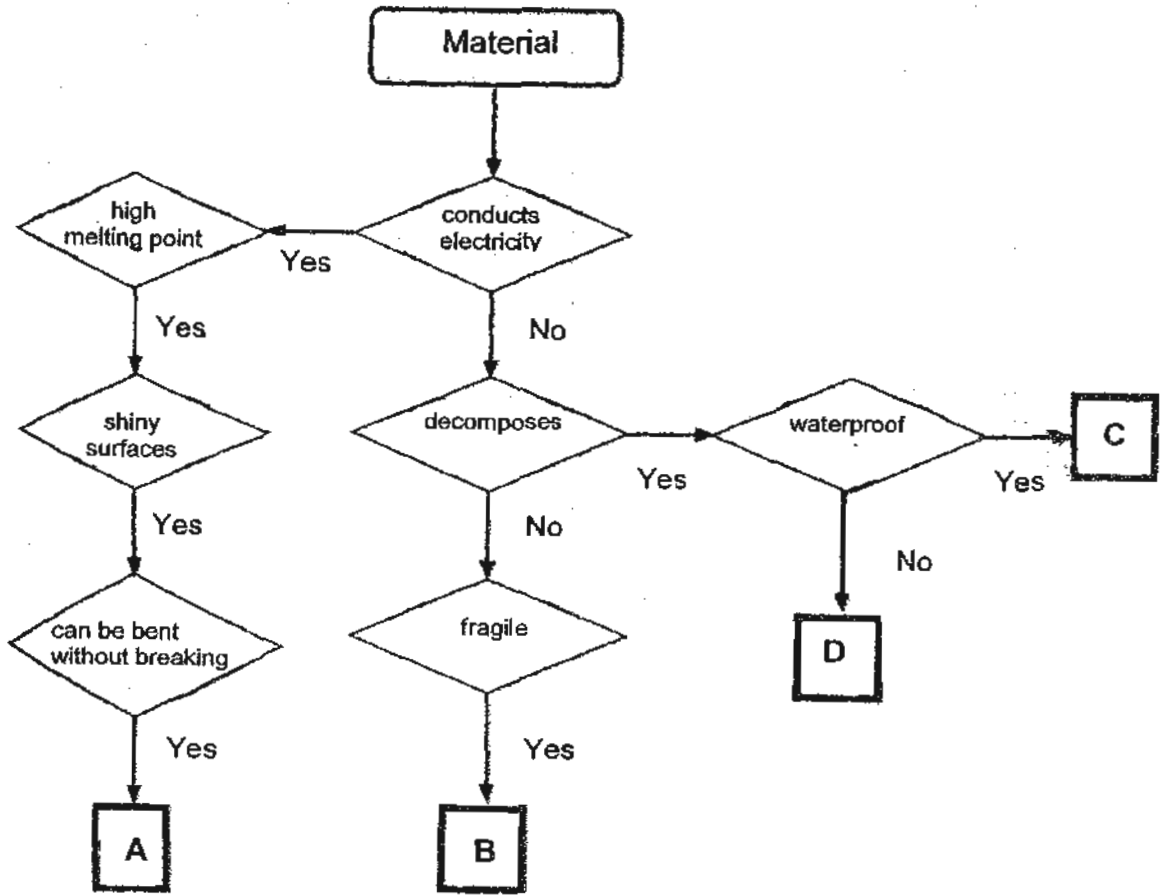

Write the correct letter A, B, C and D to match the materials given below:

(a) Porcelain : _____

(b) Silver : _____

(c) Rubber : _____

(d) Paper : _____

(2 m)

39. A beaker of water was left in a room with a temperature of $-5\text{ }^{\circ}\text{C}$ for some time as shown in Figure 1.

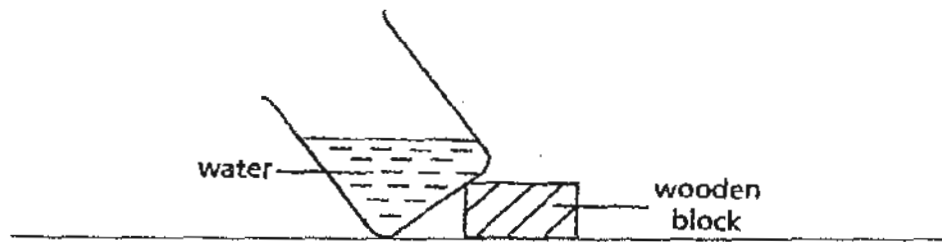

Figure 1

- (a) After some time, the beaker is taken out of the room. Draw what you would observe in Figure 2. (1 m)

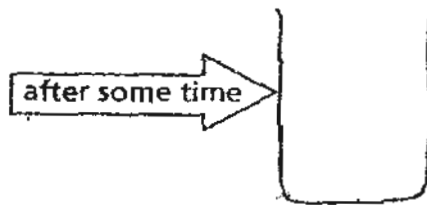
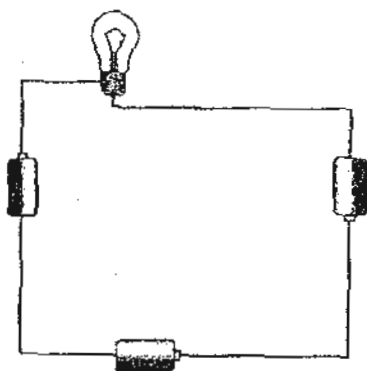

Figure 2

- (b) From the above observation, state one property about solid and liquid that this set-up demonstrates. (1 m)

40. Four electrical circuits using similar batteries and bulbs are shown below.



Circuit A

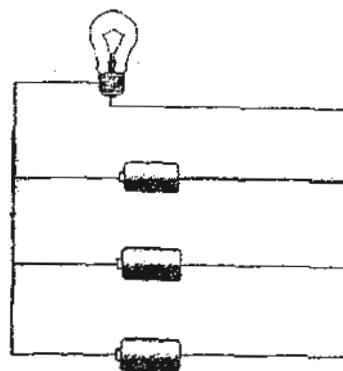

Circuit B

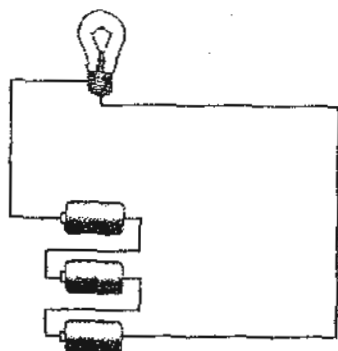

Circuit C

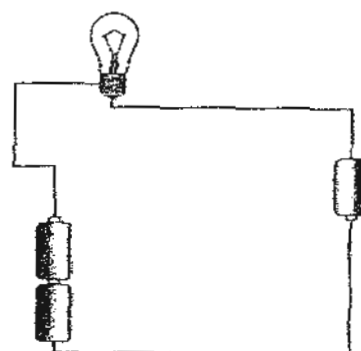

Circuit D

(a) In which two circuits are the bulbs with equal brightness? (1 m)

(b) State one advantage of arranging batteries as in Circuit B (1 m)

(c) Jane's mother advised her not to use the umbrella during a lightning storm on a rainy day. Why did Jane's mother advise her against using the umbrella? (1 m)

41. A steel nail is suspended freely midway between 2 similar iron bars, A and B.

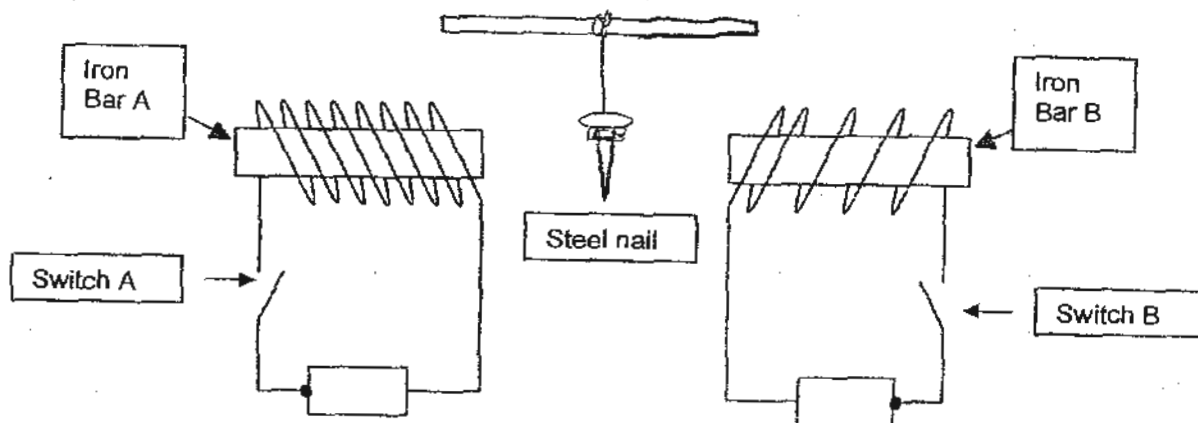

- (a) What will happen to the steel nail if only Switch B is closed? (1 m)

- (b) What will happen to the steel nail if Switch A is now also closed? (1 m)

- (c) Explain the observation in (b). (1 m)

42. Mary added some ice-cubes into a basin of tap water. Then she placed a test-tube of water into the basin as shown below. She also placed two thermometers into the set-up; one into the basin of water and ice, and the other into the test-tube as shown in the diagram here.

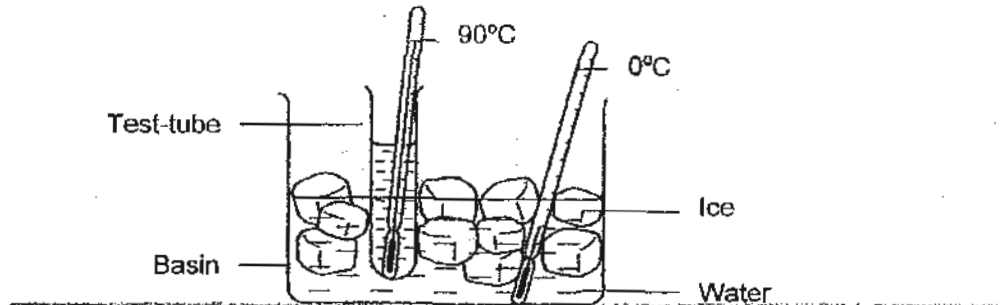

- (a) After some time, the ice cubes started to melt. What caused the ice cubes to melt? (1 m)

- (b) Which one of the following options is most likely the temperatures of the water in the test-tube and the basin after 10 minutes? Tick the correct bracket below. (1 m)

After 10 min, temperature of water in:		
Test-tube	Basin	Tick [<input checked="" type="checkbox"/>]
50 °C	70 °C	[<input type="checkbox"/>]
70 °C	10 °C	[<input type="checkbox"/>]
90 °C	0 °C	[<input type="checkbox"/>]

- (c) In the above set-up, when will the transfer of heat stop? (1 m)

43. A torchlight is shone on a pencil and a shadow is formed on the white screen.

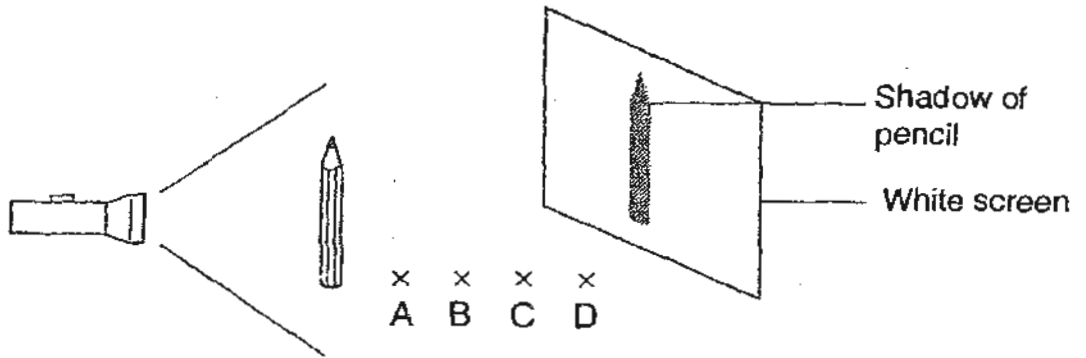

- (a) At which position, A, B, C or D, will the pencil cast the smallest shadow? (1 m)

- (b) If a ring is placed on the pencil as shown below, what would the shadow on the screen be?

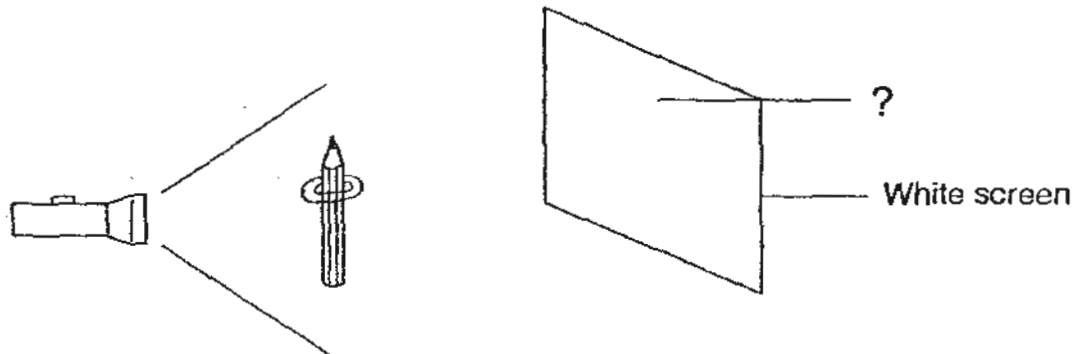

Tick the correct option.

(1 m)

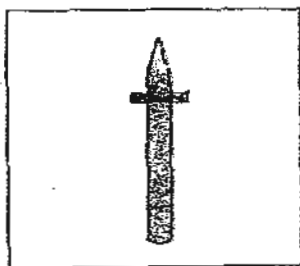



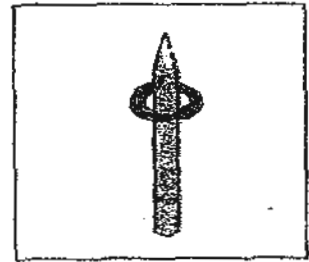

- (c) Some objects allow all or some light to pass through while the others do not. Place the following items, "Whiteboard", "Frosted window panel" and "Cling wrap" in the classification table below. (1 m)

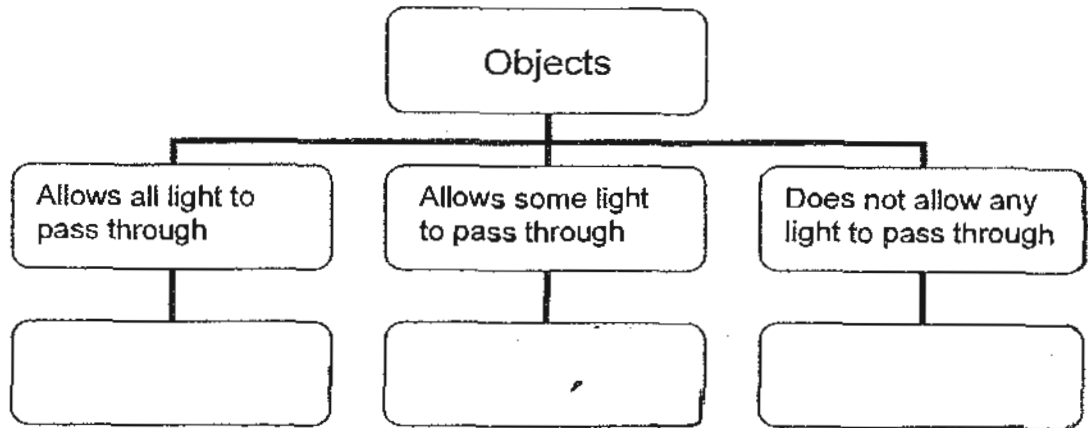

44. The diagram below shows the movement of a ball when it bounces.

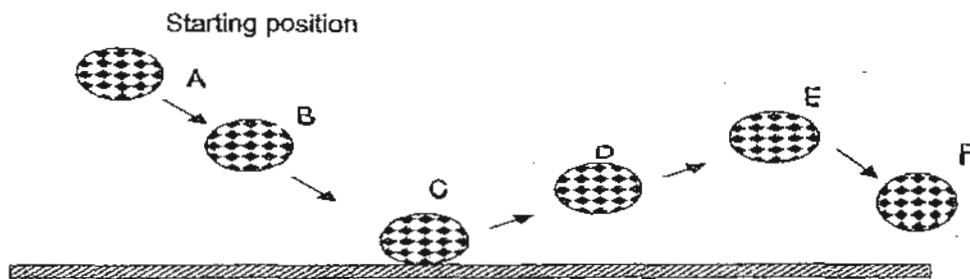

- (a) State the position where the ball has no kinetic energy (1 m)

- (b) Complete the energy conversion from Position A to C by stating only the main energy involved (1 m)

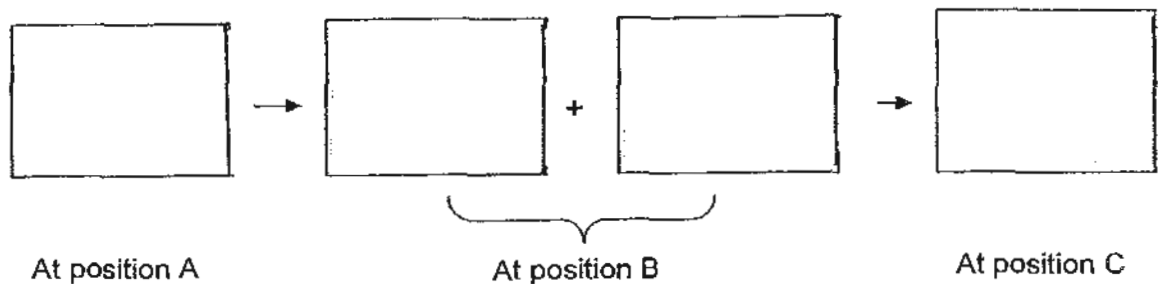

(c) Explain why Position E will never be as high as Position A?

(2 m)

----- End of Booklet B2 -----

ANSWER SHEET

EXAM PAPER 2010

SCHOOL : MGS PRIMARY
SUBJECT : PRIMARY 6 SCIENCE

TERM : SA1

Q1	Q2	Q3	Q4	Q5	Q6	Q7	Q8	Q9	Q10	Q11	Q12	Q13	Q14	Q15	Q16	Q17
2	3	1	3	3	1	4	2	3	1	3	3	3	3	4	1	2

Q18	Q19	Q20	Q21	Q22	Q23	Q24	Q25	Q26	Q27	Q28	Q29	Q30
4	1	3	2	2	4	4	2	3	2	3/4	3	4

31)a) It represents animals.

b) They cannot move from place to place by themselves.

32)a) A: Lizard B: Dragonfly C: man D: Zebra

b) Platypus.

33)a) F b) T c) U d) T

34)a) 70 beats per minute.

b) 100 beats per minute. It lasted for 20 minutes.

c) His heart was still pumping blood rich in oxygen and food to muscles for energy to make up for the loss while he exercised.

35)a) When the population of Y decreases, the population of X increases.

When the population of Y increases, the population of X decreases.

b) The prey is Y while X is the predator.

36)a) Water the plants and soil.

b) It should be placed at a place where there is sunlight or light.

c) The plants used the carbon dioxide released by the plants during respiration photosynthesis. In return, when the plants photosynthesis, it releases oxygen for the plant to carry out life processes. The water vapour released during respiration will be recycled to provide water for the plants.

37)a) There were no male guppies in Tank B, so they could not reproduce new guppies, thus, when some guppies died, the population of guppies in Tank B decreased.

b) The number of water plants in each tank and the temperature of the water in each tank.

38)a) B b) A c) C d) D

39)a)

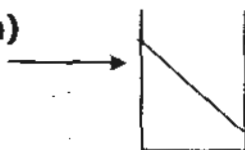

b) Liquid has no definite shape but solid has a definite shape.

40)a) Circuits C and D.

b) The bulb will light up for a longer period of time as only one battery is required to light up the bulb at any one time.

c) Lightning is a form of electricity. Her umbrella is made up of metal, which is a good conductor of electricity and allows electricity to pass through easily. Jane could be electrocuted.

41)a) It will move towards Iron Bar B.

b) It will move towards Iron Bar A.

c) Electromagnet A has more coils, it is a stronger magnet than Electromagnet B, causing the steel bar to swing towards it.

42)a) The heat from the water in the basin and the water in the test-tube.

b) 70°C 10°C ✓

c) When the water reaches room temperature.

43)a) Position D.

b)

c) Cling wrap Frosted window panel White board

44)a) A.

b) Gravitational Potential energy → Gravitational Potential energy + Kinetic energy → Kinetic energy.

c) When the ball is at position C, some energy is converted to heat and sound energy, thus, the amount of kinetic energy to be converted to gravitational potential energy is less resulting in the ball bouncing to a lower height.