



CATHOLIC HIGH SCHOOL  
PRIMARY 6  
PRELIMINARY EXAMINATION 2  
2010  
2010  
SCIENCE  
EM 1 / EM 2

(VA2)

Name: \_\_\_\_\_ ( )

Class : Primary 6 \_\_\_\_\_

Date : 30<sup>th</sup> August 2010

BOOKLET A

30 Questions  
60 Marks

Total Time for Booklets A & B: 1 hour 45 minutes

**Instructions to Candidates**

Do not open this booklet until you are told to do so.  
Follow all instructions carefully.  
Answer all questions.

6046



Section A: Multiple Choice Questions (60 marks)

For each question from 1 to 30, four options are given. One of them is the correct answer. Make your choice (1, 2, 3 or 4) on the Optical Answer Sheet.

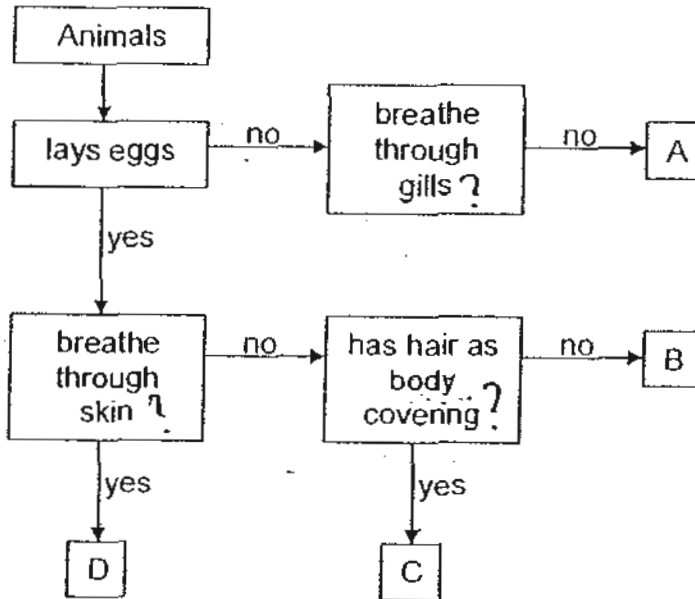
1. Study the flowchart below.

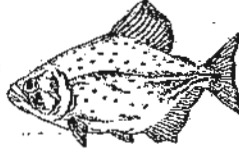
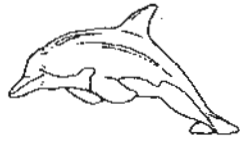

Which animals could A, B, C and D represent?

				
(1)	B	C	A	D
(2)	B	C	D	A
(3)	D	B	A	C
(4)	D	B	C	A

2. Four air samples of 100 cm<sup>3</sup> each were taken. Which of the following would most likely show the sample of air inhaled in a broken-down lift with five people trapped in it for half an hour?

	Nitrogen/cm <sup>3</sup>	Oxygen / cm <sup>3</sup>	Carbon dioxide / cm <sup>3</sup>	Other gases / cm <sup>3</sup>
(1)	78	12	9	1
(2)	78	21	0.03	0.97
(3)	78	0	20	2
(4)	63	15	21	1

3. Carl made a study on two types of habitats and recorded his observations in the table below.

Observation	Habitat A	Habitat B
Large amount of sunlight was received	✓	
Butterflies were fluttering around	✓	
Earthworms were found living here		✓
The condition was dark and damp throughout the day		✓

Which one of the following best describes habitats A and B respectively?

	Habitat A	Habitat B
(1)	Garden	Leaf litter
(2)	Swamp	Field
(3)	Seaside	Rotting log
(4)	Pond	Tropical forest

4. A flatworm only has a simple digestive system, nervous system and muscles that extend throughout its body. Dalih cut the flatworm into half and after some time, he found that there were 2 new flatworms as shown in the diagram below.

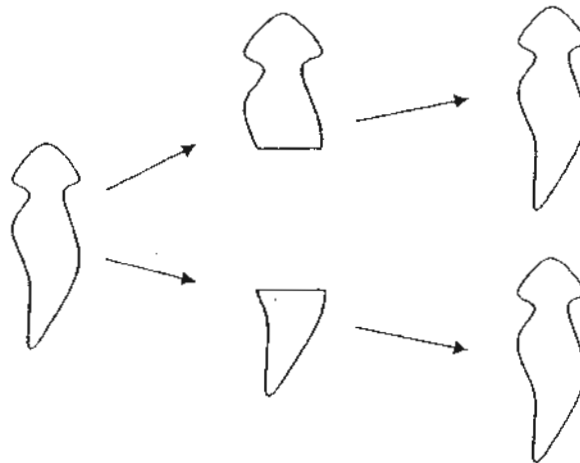

Which one of the following conclusions is best supported by the results of his observation?

- (1) Flatworms reproduce by sexual reproduction.
- (2) Cells in flatworms help them to grow new cells.
- (3) Red blood cells are required for growth of flatworms.
- (4) The muscular system of flatworms enables them to grow new cells.

5. Sang Yu wanted to investigate how his breathing rate changes with different activities. He jumped on a trampoline for 10 minutes, rested in a standing position for 10 minutes and then sat on a sofa to read his book for another 10 minutes.

Which of the following shows his breathing rate over the 30 min?

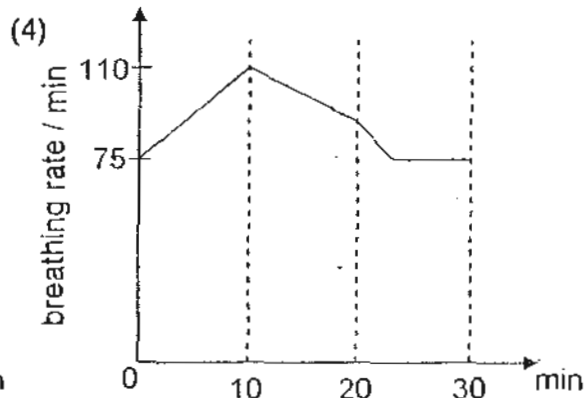
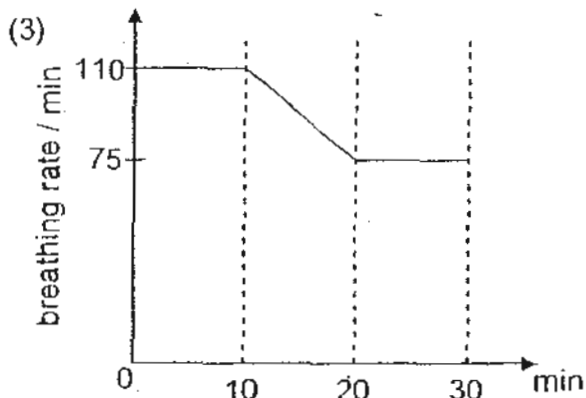
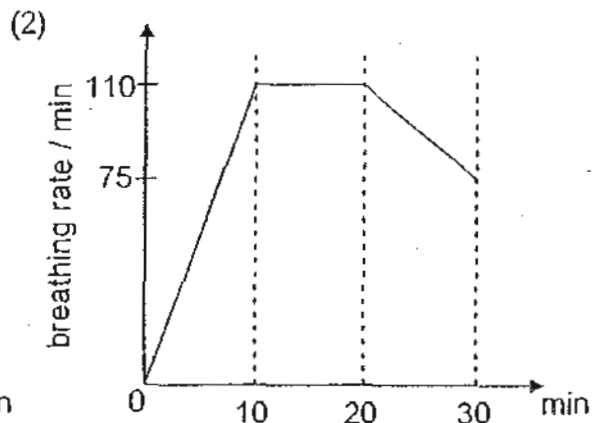
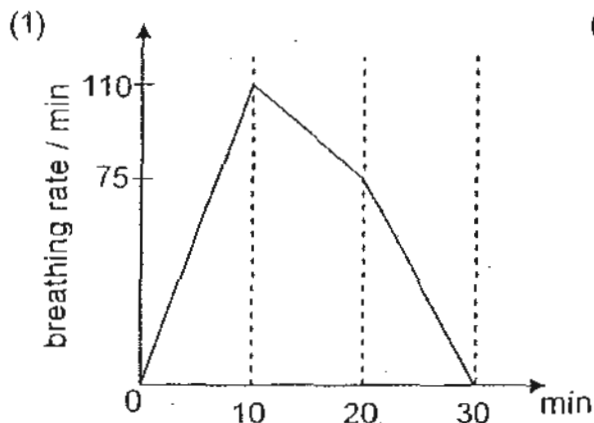

6. Four blood samples, M, N, O and P, were taken from different blood vessels in the body. The graph below shows the amounts of oxygen in each of these blood samples.

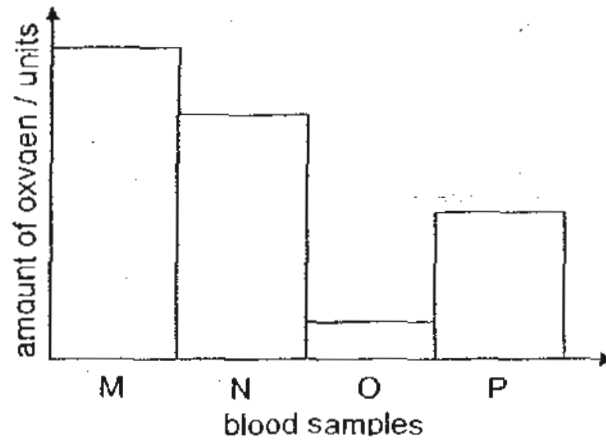

Which blood samples were most likely taken from the following blood vessels?

Blood vessels carrying blood from	
lungs to heart	heart to lungs
(1) N	O
(2) M	O
(3) M	P
(4) P	N

7. Study Joanne's family tree below carefully.

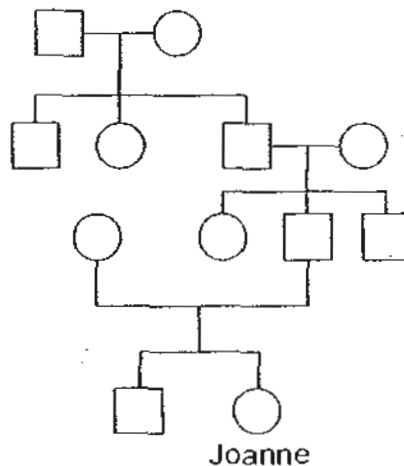

Which one of the following statements is true?

- (1) Joanne has 2 brothers.
- (2) Joanne has 1 uncle and 1 aunt.
- (3) Joanne's grandfather has 3 siblings.
- (4) There are 3 generations in Joanne's family tree.

8. Mr. Quek wanted to convince his pupils that plants can take in water through their roots. Which of the following set-ups should he use for his classroom demonstration?

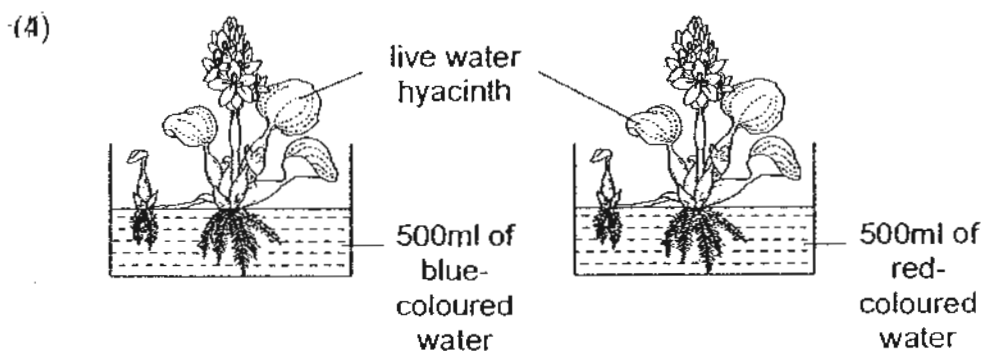
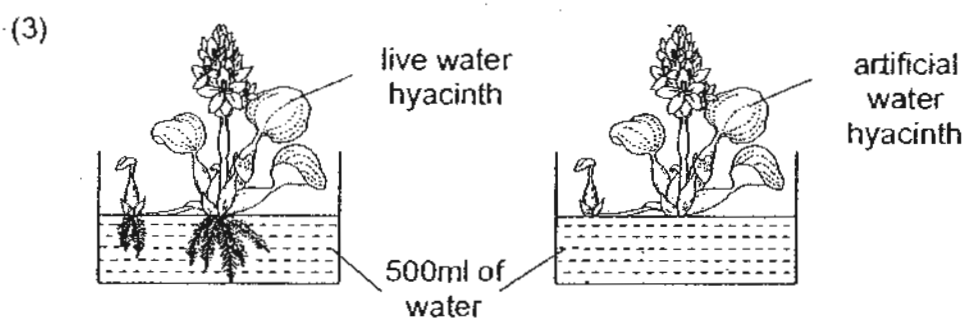
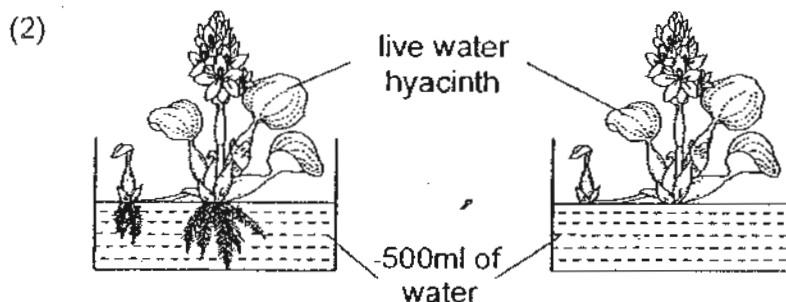
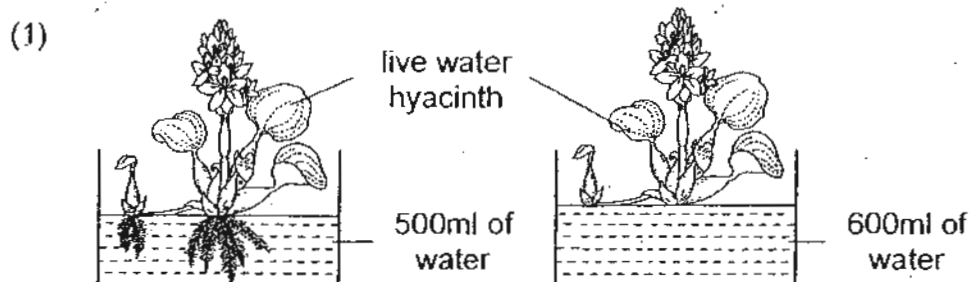

9. A plant in the science garden had a ring of water-carrying tube and food-carrying tube removed. The plant was watered daily. Leaf G was partially covered with aluminium foil on both its sides.

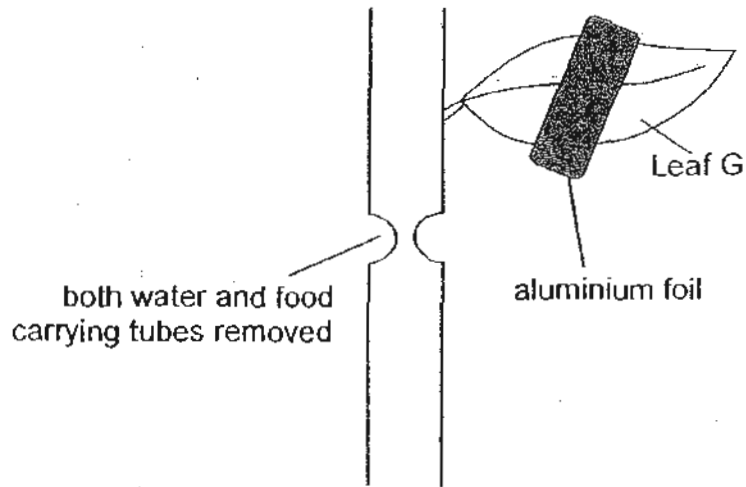

After 3 days, leaf G was tested for starch.

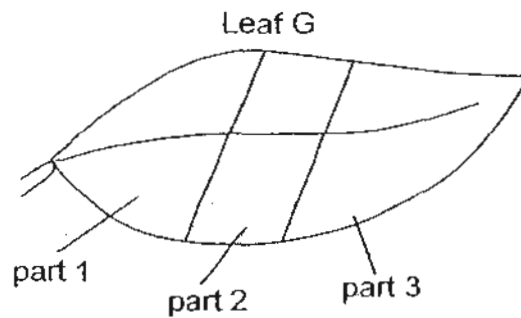

Which part(s) of the leaf would the iodine solution remain brown?

- (1) Part 1 only
- (2) Part 2 only
- (3) Parts 1 and 3 only
- (4) Parts 1, 2 and 3

10. Paul caught three different types of animals X, Y and Z from a pond and put them into two aquariums, 1 and 2. He put animals X and Y into aquarium 1 and animals X and Z into aquarium 2. He also put some plants into both aquariums.

Paul counted the number of animals in each aquarium every week for one month and plotted his findings in the graphs below. He did not see any dead animals in both aquariums.

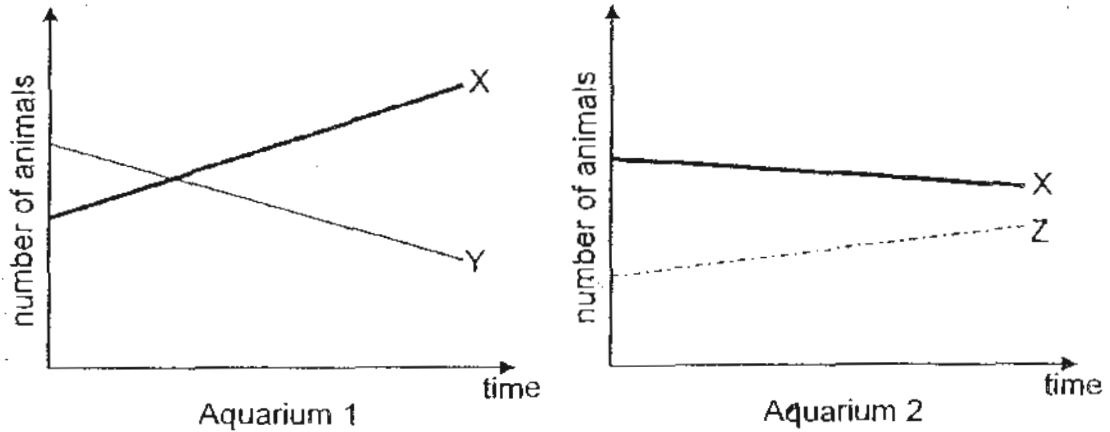

From the graphs above, which one of the following correctly shows the relationship between animals X, Y and Z?

- (1)  $X \rightarrow Y \rightarrow Z$
  - (2)  $Y \rightarrow X \rightarrow Z$
  - (3)  $Z \rightarrow X \rightarrow Y$
  - (4)  $Z \rightarrow Y \rightarrow X$
11. The table below shows the classification of fruits and seeds based on their method of dispersal.

Fruits / Seeds			
Group E	Group F	Group G	Group H
Rubber	Dandelion	Coconut	Love grass
Balsam	Angsana	Pong pong	Mimosa

Study seed X shown below.

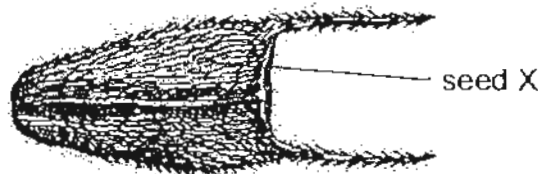

In which group does seed X belong to?

- (1) Group E
- (2) Group F
- (3) Group G
- (4) Group H

12. Insect X feeds on the pollen and flower tissues of Plant Y. The number of insect X depends on the number of Plant Y. Winters are too cold and summers are too dry for many flowers to bloom.

Which one of the following graphs is most likely to represent the number of insect X in the course of one year?

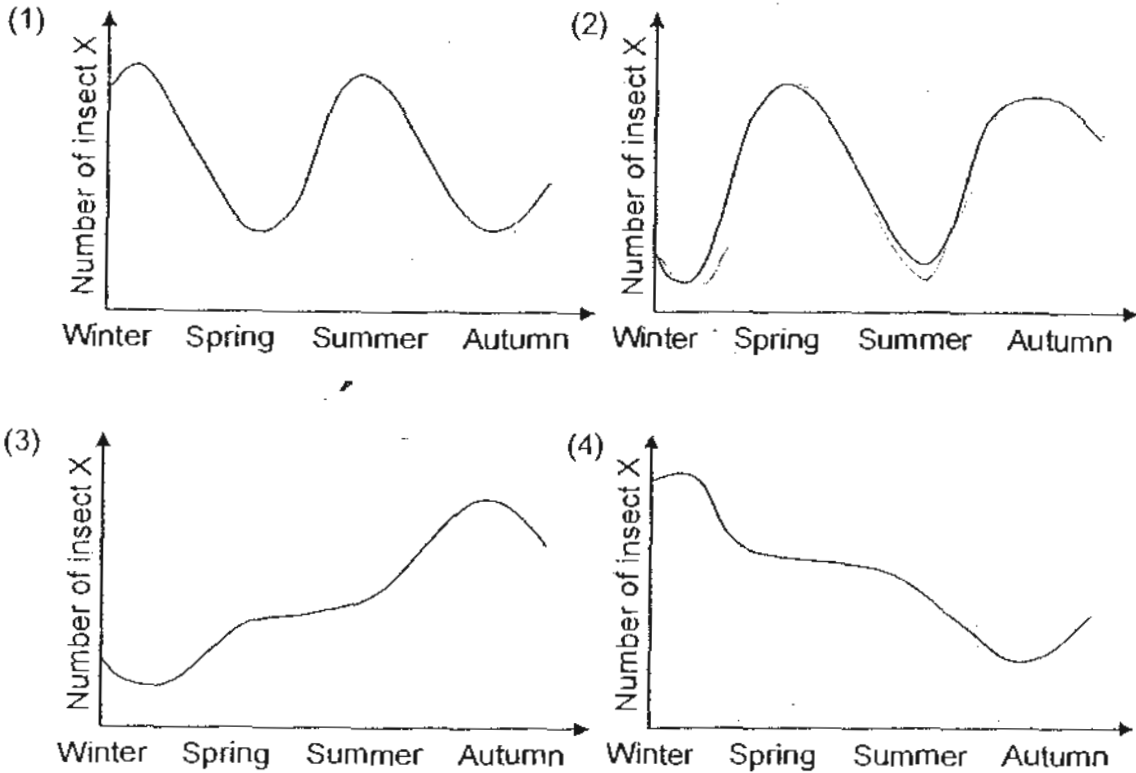

13. Rachel carried out an experiment to see how the amount of carbon dioxide affects the rate of photosynthesis in a plant. Which of the following correctly shows the results of her experiment if she had carried out a fair test?

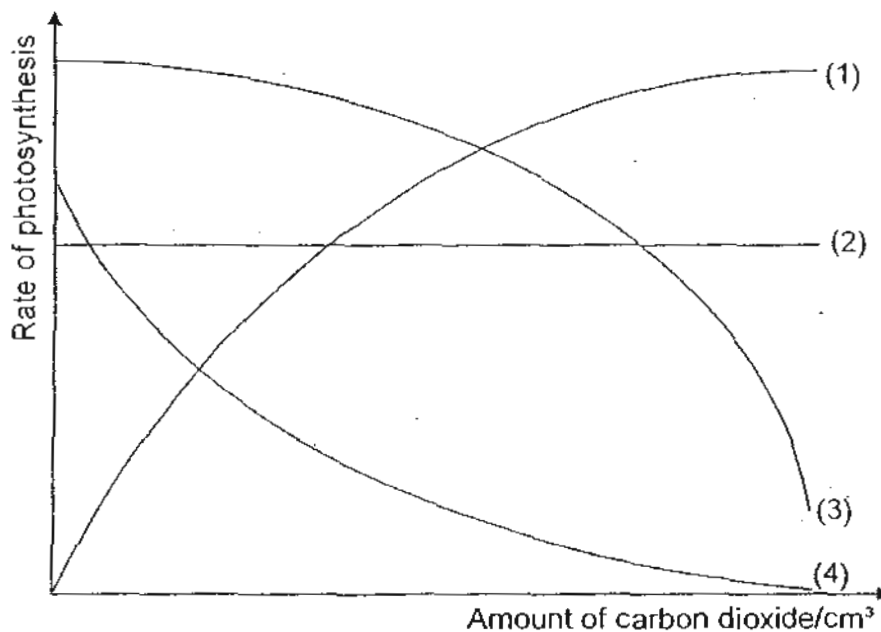

14. Angie planted four seedlings in 200 cm<sup>3</sup> of cotton wool and another four similar seedlings in 200 cm<sup>3</sup> of garden soil. She left both groups by the window and watered them daily for 30 days without giving any fertilisers. Every five days, Angie would measure and record the height of the plants. Her findings are in the table below.

Day	Average height of seedlings in garden soil / cm	Average height of seedlings in cotton wool / cm
0	1.5	3.1
5	3.9	5.2
10	5.7	6.8
15	7.4	8.0
20	9.0	10.3
25	12.6	12.5
30	14.4	14.8

Which of the following conclusions can Angie make based on her experiment results?

- Different seedlings grow at different rates.
- Seedlings grown in garden soil grow faster.
- Cotton wool can hold more water for the seedlings to use for photosynthesis.
- Planting seedlings in cotton wool and garden soil does not affect the rate of growth of the seedlings.

15. Study the concept map below carefully.

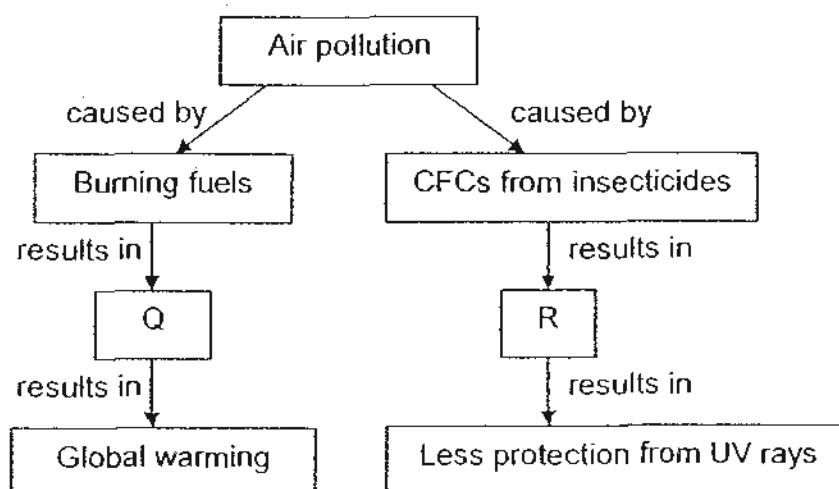

What are Q and R likely to be?

	Q	R
(1)	Formation of acid rain	Greenhouse effect
(2)	Greenhouse effect	Depletion of ozone layer
(3)	Depletion of ozone layer	Greenhouse effect
(4)	Depletion of ozone layer	Formation of acid rain

- Jackson*
16. Percy wanted to find out what is the best material to make a container that can hold at least 2 litres of water. He chose the following materials of the same size, A, B, C and D, and conducted a few experiments on each of them. The table below shows the results of the experiments.

Material \ Test	A	B	C	D
Put a brick on it	It stretched	No visible change	No visible change	No visible change
Put in water	It floated	It sank	It sank	It floated
Hit by a hammer a few times	It flattened	It broke	It flattened	A few scratches were observed
Connected to a circuit tester	Light bulb did not light up	Light bulb did not light up	Light bulb lighted up	Light bulb did not light up

Based on the information given above, which material is the most suitable to make the container?

- (1) A  
 (2) B  
 (3) C  
 (4) D
17. Diagram 1 below shows what happens when the first side of Disc X faces Disc Y and Diagram 2 shows the second side of Disc X facing the same side of Disc Y.

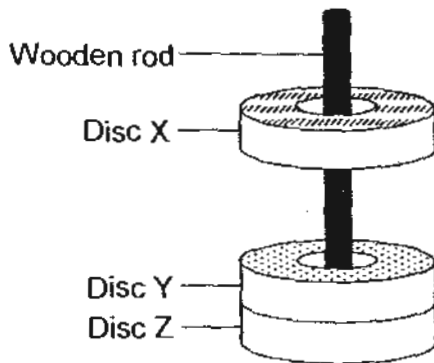

Diagram 1

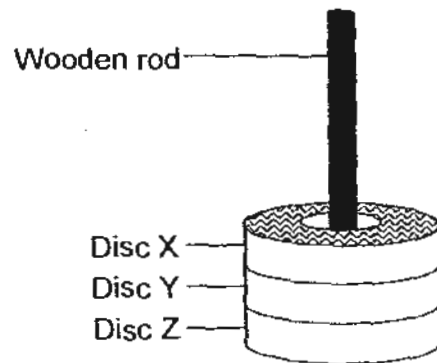

Diagram 2

Based on the above diagrams, what could we conclude about Discs X, Y and Z?

- A Disc X is a magnet.  
 B Disc Y is a magnet.  
 C Disc Y is magnetic.  
 D Disc Z is non-magnetic.

- (1) A and B only  
 (2) C and D only  
 (3) A, B and D only  
 (4) B, C and D only

18. The table below shows the freezing points and boiling points of three unknown substances, P, Q and R.

Substance	Freezing point °C	Boiling point/°C
P	36	85
Q	23	126
R	48	130

Which of the substances, P, Q and R, is/are solid at 40°C?

- (1) P only
  - (2) R only
  - (3) P and Q only
  - (4) Q and R only
19. The diagrams below show what happened to substances Y and Z when the container was tilted at an angle.

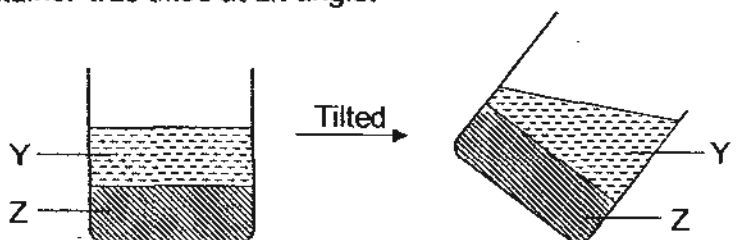

Based on the observations, which one of the following shows correctly the state of substances Y and Z respectively?

	Y	Z
(1)	Solid	Liquid
(2)	Liquid	Liquid
(3)	Liquid	Solid
(4)	Solid	Gas

20. The experiment below is conducted in a dark room.

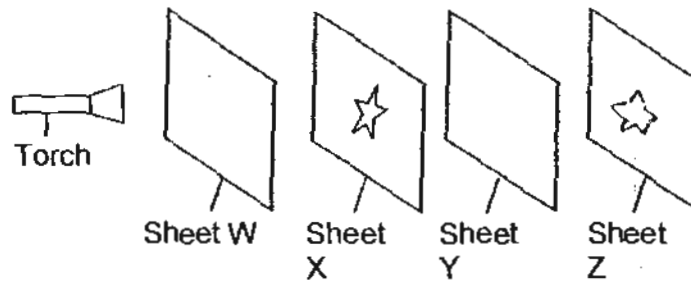

Sheets W, X, Y and Z are arranged in a straight line. When the torch is switched on, a dim star patch of light is seen on Sheet Z only.

What can be done in order to make the patch of light on Sheet Z brighter?

- A Paint Sheet Z white
- B Make Sheet X thicker
- C Move Sheet W closer to the torch
- D Replace Sheet Y with a clear glass sheet

- (1) A and B only
- (2) A and C only
- (3) A, B and D only
- (4) B, C and D only

21. Ivan wanted to investigate the temperature change in water as it evaporates. He placed 2 beakers of water in the room and measured the temperature of the water throughout the experiment. He also recorded the time taken for the water in each beaker to be reduced to 20ml.

The table below shows the initial temperature and amount of water in the two beakers at the start of the experiment and the time required for the water in each beaker to be reduced to 20ml.

Beaker	Initial temperature of water/ $^{\circ}\text{C}$	Amount of water at beginning/ml	Time taken for water to be reduced to 20ml/min
A	27	60	50
B	27	60	30

Which of the following correctly shows the temperature of the water in the 2 beakers after 30 minutes?

	Beaker A	Beaker B
(1)	$5^{\circ}\text{C}$	$0^{\circ}\text{C}$
(2)	$27^{\circ}\text{C}$	$27^{\circ}\text{C}$
(3)	$27^{\circ}\text{C}$	$30^{\circ}\text{C}$
(4)	$95^{\circ}\text{C}$	$100^{\circ}\text{C}$

22. Study the circuit diagram below. All the switches and batteries in the circuit were identical. P, Q and R were made of 3 different materials.

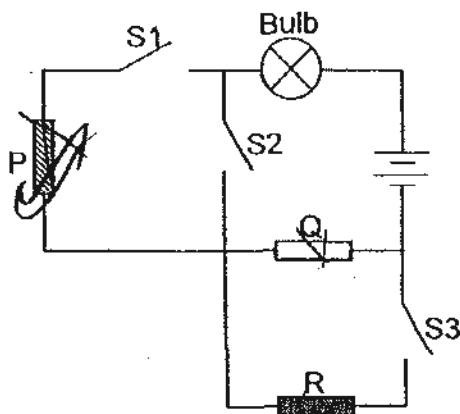

The table below shows the observations when the various switch(es) was/were closed.

Switch on	Observation
S1 only	Bulb did not light up
S1 and S2 only	Bulb did not light up
S1 and S3 only	Bulb lighted up

Which one of the following correctly matches the materials of P, Q and R respectively?

	P	Q	R
(1)	Plastic	Rubber	Carbon
(2)	Rubber	Copper	Plastic
(3)	Carbon	Plastic	Aluminium
(4)	Aluminium	Carbon	Copper

23. Su Ling wanted to conduct an experiment to find out how the rate of evaporation of water is affected by the amount of wind and sunlight. She measured the mass of 4 pieces of cloth, A, B, C and D, that were soaked in water at the beginning and at the end of the experiment. The table below shows the conditions under which the cloths were placed and the mass of A, B, C and D at the beginning of the experiment.

Cloth	Condition	Mass at the beginning of the experiment/g
A	Windy and in the room	25.6
B	Windy and under the sun	26.4
C	No wind and in the room	25.8
D	No wind and under the sun	26.0

Which one of the following correctly matches the pair of cloths that she could have used to compare the results respectively?

(1)

Condition	Cloth	Mass at the end of the experiment/g
Wind	A	24.8
	B	25.0
Sunlight	C	25.2
	D	25.2

(2)

Condition	Cloth	Mass at the end of the experiment/g
Wind	A	24.8
	C	25.2
Sunlight	C	25.2
	D	25.2

(3)

Condition	Cloth	Mass at the end of the experiment/g
Wind	B	25.0
	D	25.2
Sunlight	A	25.6
	B	25.0

(4)

Condition	Cloth	Mass at the end of the experiment/g
Wind	B	25.8
	D	25.2
Sunlight	C	25.2
	D	25.2

24. A plastic ball and a metal ball were dropped at the same time from the top of a slope. Both balls moved through 2 different paths as shown in the diagram below.

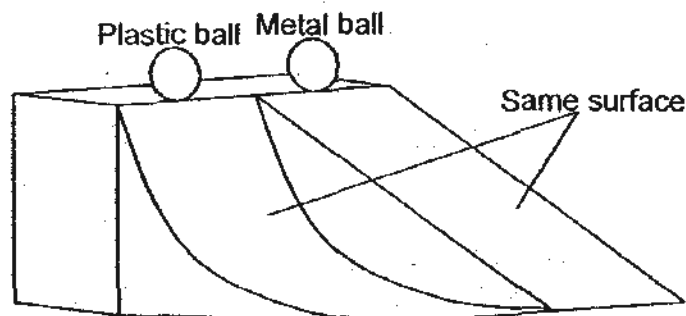

The amount of time that each ball took to reach the bottom of the slope was recorded. Which one of the following correctly describes and explains the observations made?

- (1) Metal ball reached the bottom of the slope first as it had a greater amount of gravitational potential energy.
  - (2) Metal ball reached the bottom of the slope first as it gained greater speed travelling along a shorter path.
  - (3) Plastic ball reached the bottom of the slope first as it had to overcome less frictional force between the surface and itself.
  - (4) Both balls reached the bottom of the slope at the same time as both had the same amount of gravitational potential energy.
25. The diagram below shows an electric motor. When the free end of the wire touches the side of the magnet, the magnet and the screw will start to spin.

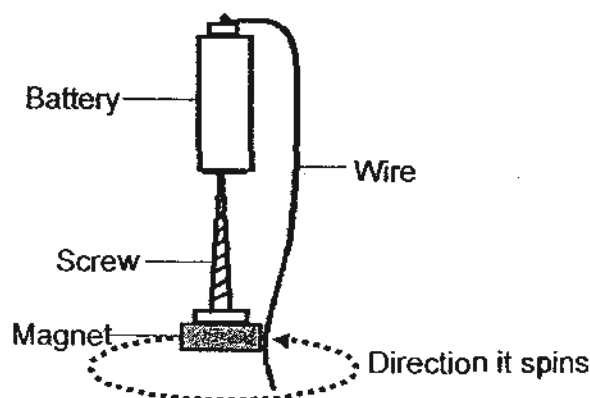

Based on the above information, state the energy conversions that cause the magnet and screw to spin?

- (1) Kinetic energy → heat energy → electrical energy
- (2) Kinetic energy → electrical energy → chemical potential energy
- (3) Chemical potential energy → heat energy → electrical energy
- (4) Chemical potential energy → electrical energy → kinetic energy

26. Joseph conducted an investigation to find out how the length of a spring changes with mass. He measured the length of the spring when different number of identical marbles were placed on the pan as shown below.

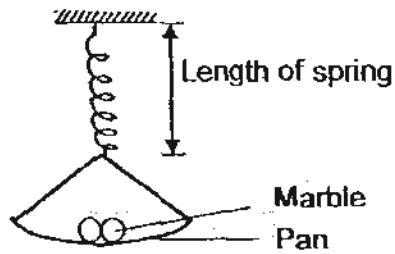

The results obtained were used to plot the graph as shown below.

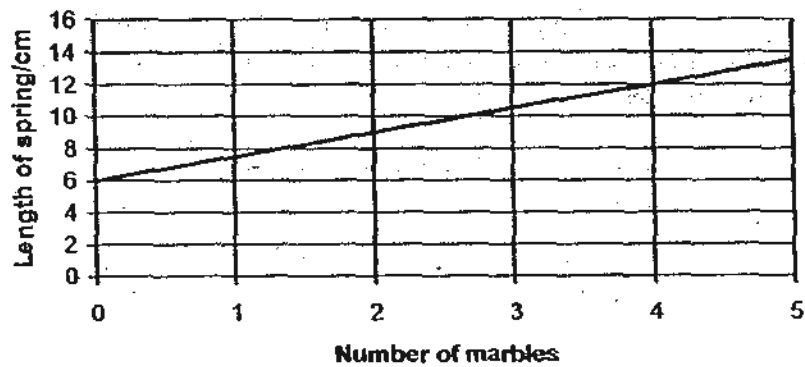

What was the extension of the spring when 2 marbles were placed on the pan?

- (1) 3 cm
- (2) 6 cm
- (3) 7 cm
- (4) 9 cm

27. A block was placed on a board, P, and was pulled to a fixed distance before it was released as shown in the diagram below.

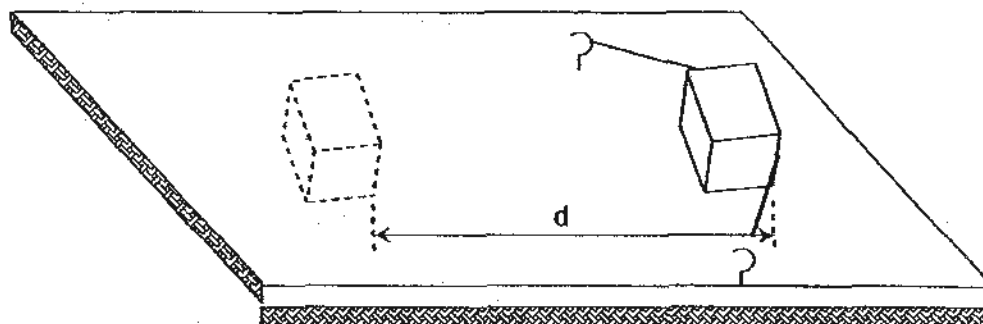

The distance at which it moved,  $d$ , was recorded. The experiment was repeated on another three identical boards with different surfaces, Q, R and S. The results were recorded in the table below.

Type of surface	Distance moved, $d/cm$
P	28
Q	37
R	19
S	5

Which surface would be the most suitable to make a slope for people to walk up to a certain height quickly?

- (1) P
- (2) Q
- (3) R
- (4) S

28. The diagrams below show a slinky on top of the staircase and when it was dropping down a staircase.

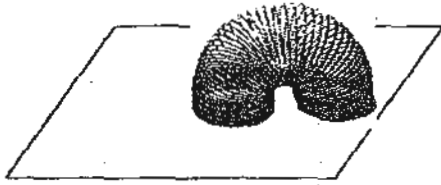

Slinky on top of the staircase

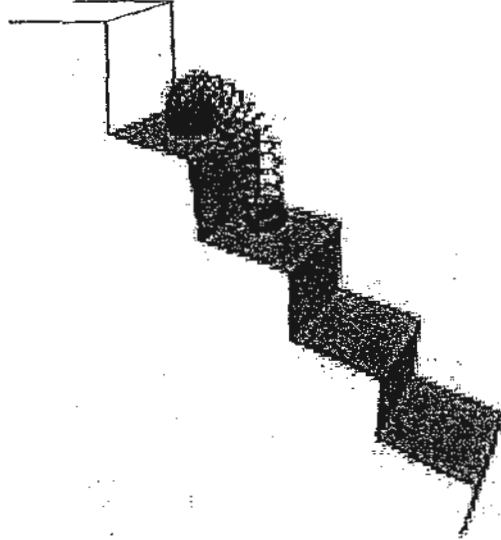

Slinky dropping down the staircase

A comparison on the forces that act on the slinky at the 2 positions is shown in the table below.

	On top of the staircase	Dropping down the staircase
A	No gravitational force	Has gravitational force
B	Smaller amount of frictional force	Greater amount of frictional force
C	Greater amount of elastic spring force	Smaller amount of elastic spring force

Which of the above is/are correct comparison(s) made on the force(s) that act(s) on the slinky at the 2 positions?

- (1) A only
- (2) B only
- (3) A and B only
- (4) B and C only

29. 2 identical balls, A and B, were raised to different heights. A had a bigger mass than B. Which one of the following graphs correctly shows the amount of gravitational force of the earth acting on the 2 balls at different heights?

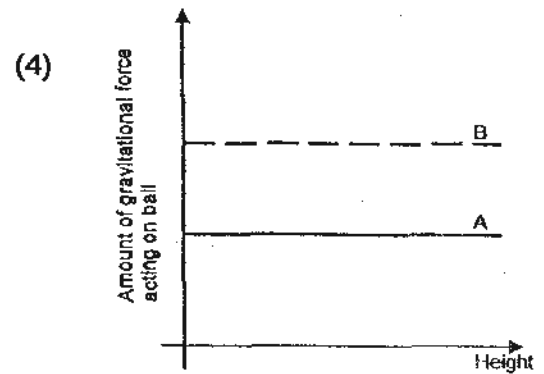
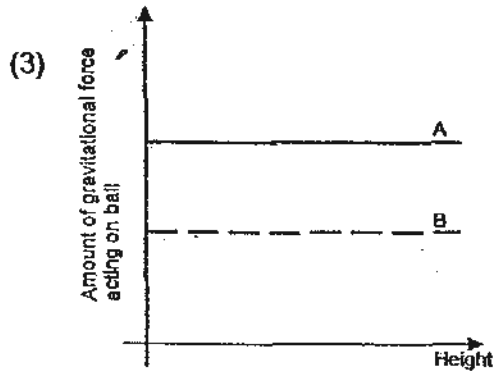
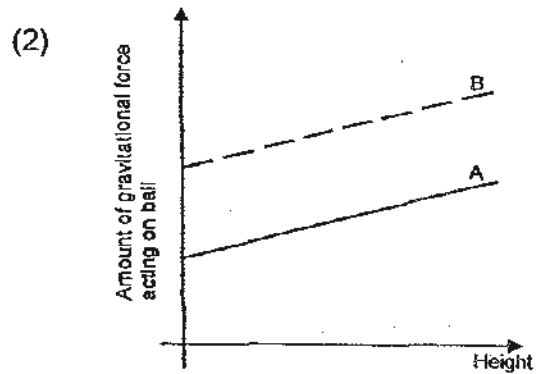
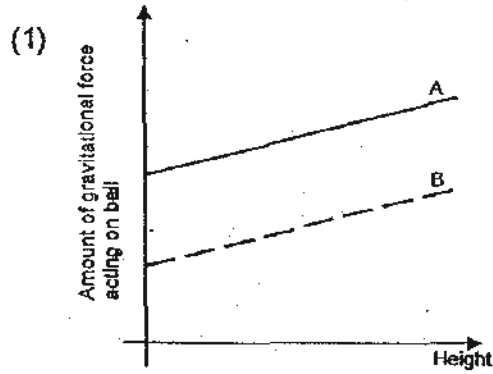

30. Joan wanted to find out how the various activities of the town affected the air pollution level. She placed 4 identical pieces of sticky pads, A, B, C and D, at 4 different locations around the town. The diagrams below show the sticky pads at the end of the experiment. The more dots shown on the pad indicates a greater amount of pollution in the air.

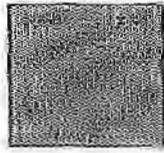

A

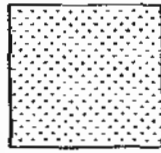

B

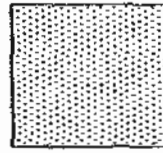

C

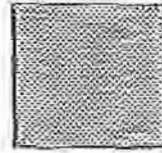

D

Based on the above information, which of the activities correctly matches the sticky pad to the different locations of the town?

(1)

Sticky Pad	Location of the town
A	Park
B	Home
C	School
D	Factories

(2)

Sticky Pad	Location of the town
A	Home
B	School
C	Factories
D	Park

(3)

Sticky Pad	Location of the town
A	Factories
B	School
C	Home
D	Park

(4)

Sticky Pad	Location of the town
A	Park
B	Factories
C	School
D	Home

-End of Section A-





**CATHOLIC HIGH SCHOOL  
PRIMARY 6  
PRELIMINARY EXAMINATION 2  
2010**

**SCIENCE  
EM 1 / EM 2**

Name: \_\_\_\_\_ ( )

Class : Primary 6 \_\_\_\_\_

Date : 30<sup>th</sup> August 2010

**BOOKLET B**

16 Questions  
40 Marks

Total Time for Booklets A & B: 1 hour 45 minutes

**Instructions to Candidates**

Follow all instructions carefully.  
Answer all questions.

Parent's Signature: \_\_\_\_\_

Date: \_\_\_\_\_

Score	
Section A	60
Section B	40
Total	100

Section B: Open-ended Questions (40 marks)

Read the following questions carefully and write your answers in the space provided. The maximum marks that can be awarded are shown at the end of each question or part-question.

31. Raja wanted to investigate the effect that the colour of flowers had on the number of butterflies that land on it. He made flowers of the same sizes using similar types of paper of different colours. In the middle of each flower, he attached a ball of cloth soaked in 10ml of sugar solution.

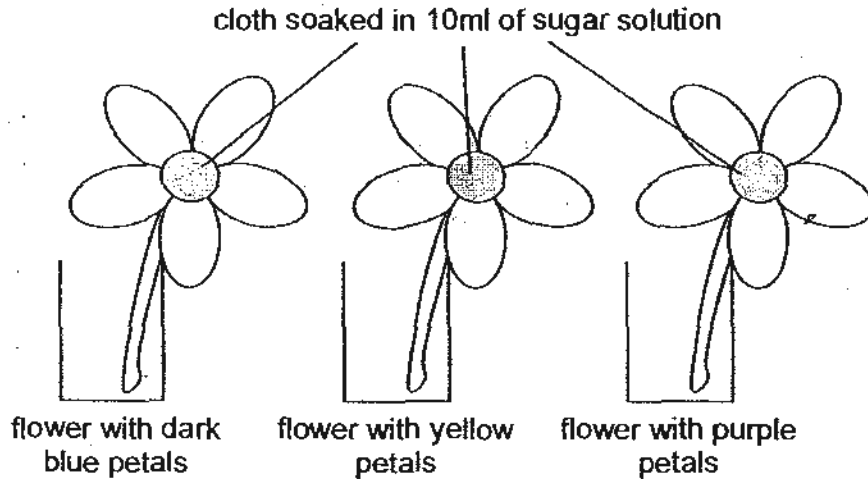

Raja placed the 3 flowers in a garden and counted the number of butterflies that landed on each flower over 4 hours.

- (a) State one other variable Raja must keep unchanged throughout the experiment.

[1]

Raja recorded his observations in the table below.

Colour of flower	Number of butterflies that had landed on the flowers			
	1 <sup>st</sup> hour	2 <sup>nd</sup> hour	3 <sup>rd</sup> hour	4 <sup>th</sup> hour
Dark blue	2	3	2	2
Yellow	6	8	7	6
Purple	3	4	3	3

- (b) What can Raja conclude from his experimental results?

[1]

- (c) How does the colour of flowers aid in the process of pollination?

[1]

32. Diana prepared the following set-up.

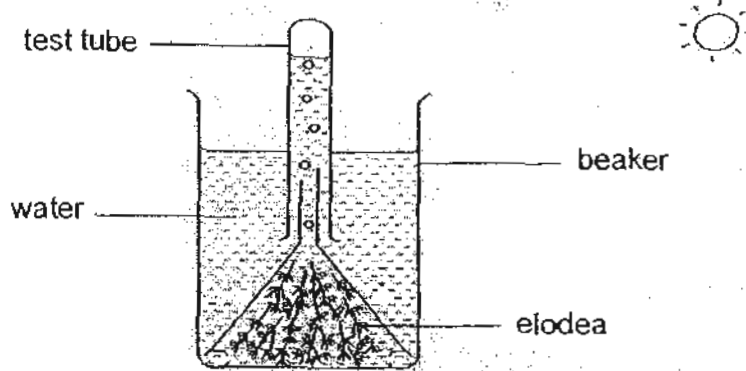

She varied three similar set-ups as shown in the table below and left them in an open field. After 30 min, she measured the height of the gas collected in the test tube.

Set-up	Amount of water / ml	Amount of elodea in beaker / g
A	300	50
B	300	100
C	300	150

(a) What is Diana trying to investigate in her experiment? [1]

---



---

(b) In the box below, draw the control set-up that Diana should have. [1]

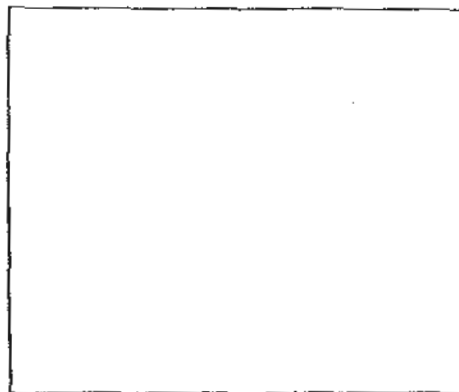

(c) Explain the purpose of the control set-up in (b). [1]

---



---

33. The food web below represents the population of organisms in a habitat.

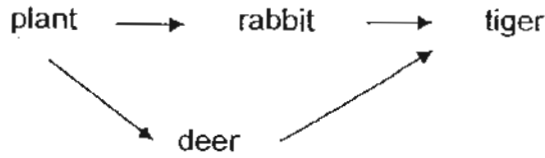

(a) The diagram below shows the jawbone of an animal "Q".



Insert "Q" into the food web above appropriately.

[1]

(b) Sabrina counted the plant and deer populations in the same habitat over a period of two years and plotted her findings in the graph below.

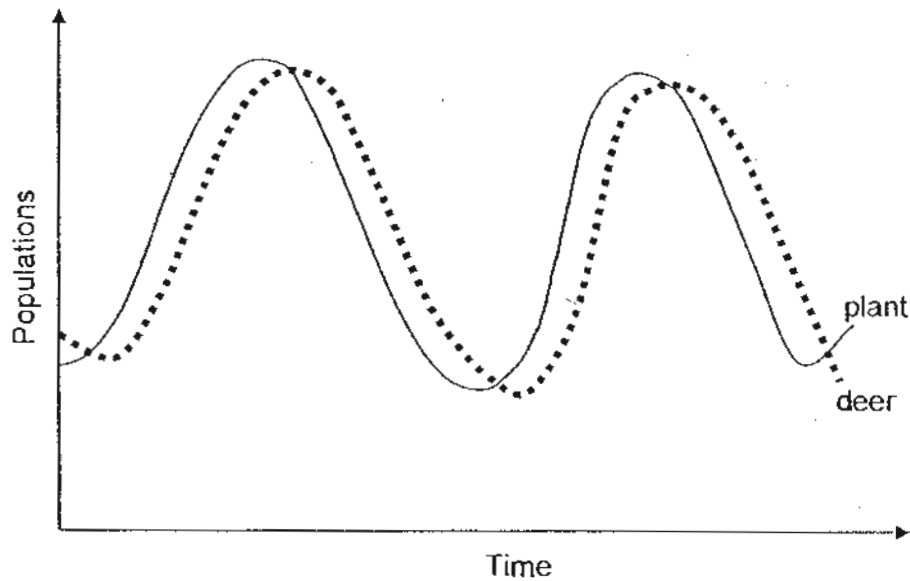

In the graph above, draw and label a line to represent the tiger population in relation to the plant and deer populations.

[1]

(c) Explain why the increase in the plant population does not happen at exactly the same time as the increase in the deer population.

[1]

---



---

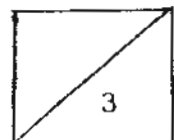

- (d) Study the diagram below. A tiger has stripes on its body and its hind limbs are longer than its fore limbs.

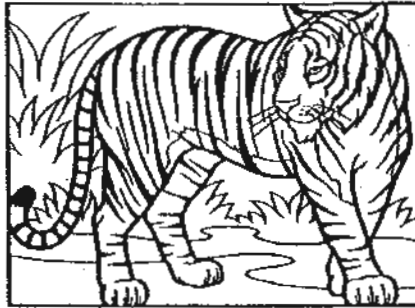

Based on the diagram above, explain how the structural adaptation helps the tiger to prey on rabbits. [1]

---



---

34. A group of pupils wanted to find out the temperature changes in a pond and a leaf-litter habitat. They took turns to use a data logger to measure the temperature in both habitats at 6 a.m., noon, 6 p.m. and midnight.

Fill in the table below with suitable headings so that the group of pupils can use it to record their investigations. [2]

(a)	(b)	
	(c)	(d)
6 a.m.		
Noon		
6 p.m.		
Midnight		

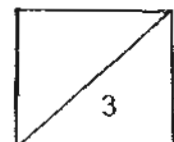

35. The shrimp digs a deep burrow in the sand on the seabed. However, it has poor vision. The goby stands guard at the entrance of the burrow and signals the shrimp with a flick of its tail when it is safe to come out. The goby, in turn, gets a burrow to live in.



Shrimp

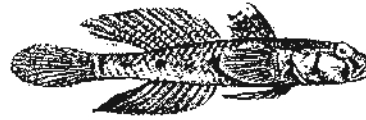

Goby

Based on the information provided, what mutual benefits can the shrimp and goby get from living close to each other? [2]

---

---

---

36. Some seabirds like Guillemots and Murres nest on the bare ledges of cliffs on islands. This is a behavioural adaptation that increases the chances of their young surviving.

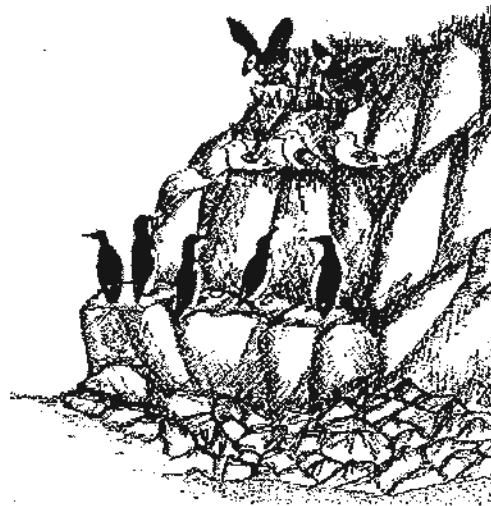

- (a) Ahmad conducted an experiment with a spinning top and a ping pong ball. He spun both top and ping pong ball on the table and observed the following.

Top:	stops spinning and remained on the table
Ping pong ball:	rolled off the table

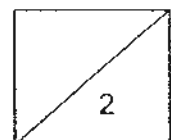

The pictures below show a Murre's egg and a top.

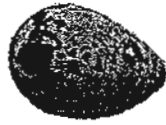

Murre's egg



Top

How is the egg of the Murre adapted to survive on cliffy terrains based on Ahmad's experiment? [1]

---

---

- (b) The terrain of these seabirds' nesting grounds is rocky and steep. Only the seabirds are able to live on this terrain. How does this type of terrain help to increase the chances of their offspring's survival? [1]

---

---

- (c) The Murre can plunge into the seawater to catch fish and other marine life. The pictures below show the Murre diving into the seawater for food.



Identify the two body features of the Murre that enable it to move in water. [1]

i. \_\_\_\_\_

ii. \_\_\_\_\_

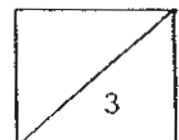

37. A research scientist selected four similar plants that were infested with 50 aphids each for an experiment. He wanted to investigate how the amount of pesticide used on the plants affects the effectiveness of ridding the plants of aphids. He sprayed the same type of pesticide on the parts of the plants infested with aphids.

The table below shows the set up of his experiment.

Plant	Amount of pesticide sprayed daily / ml	Number of aphids left after 1 week
A	0	62
B	6	40
C	12	27
D	18	13

- (a) What conclusions can the research scientist make from his experiment? [2]

---

---

---

---

- (b) Give a reason why using pesticides on vegetable farms to get rid of aphids can harm people. [1]

---

---

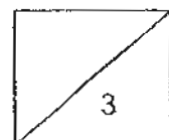

38. Henry wanted to find out which type of magnetic material, iron, steel, nickel and cobalt, is the strongest. He conducted an experiment as shown below.

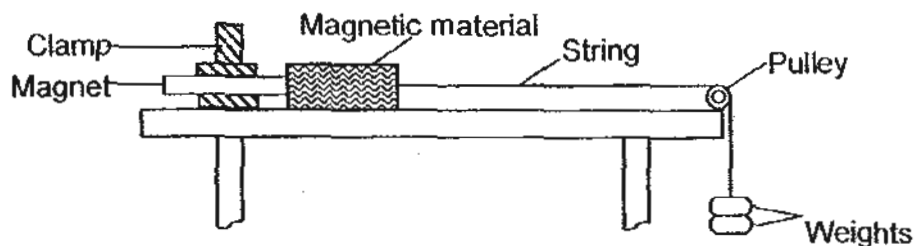

He kept adding weights until the magnetic material was no longer attracted to the magnet. He repeated the experiment with different magnetic materials and the results are shown below.

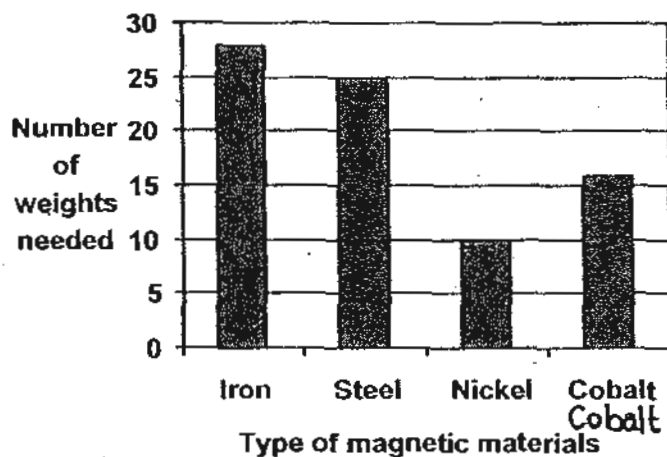

- (a) State one variable that he must keep constant in order for the experiment to be fair? [1]

- (b) In a scrap yard, an electromagnet is used to separate the magnetic metals from the non-magnetic ones by coiling the magnetic material with a wire and passing electricity through the wire.

- (i) Based on the information above, state which one of the magnetic materials would be most suitable in making the electromagnet in the scrap yard so as to separate the metals as fast as possible? Give a reason for your choice. [1]

- (ii) State one way how we can increase the strength of the electromagnet used in the scrap yard. [1]

39. Freddy set up an experiment as shown below.

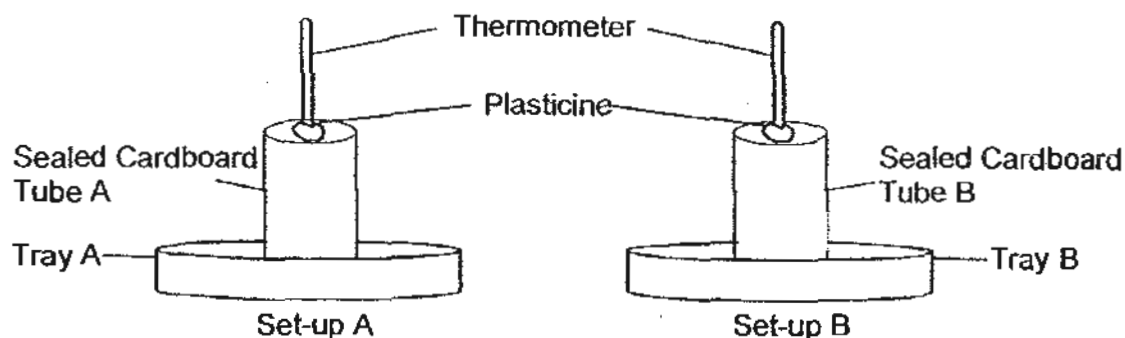

He added 100 ml of water in Tray A only and left both set-ups in the room. He recorded the temperature in the 2 tubes at equal intervals as shown in the table below.

Time/min	Temperature in tube/ $^{\circ}\text{C}$	
	A	B
0	30	30
10	29	30
20	28	30
30	26	30
40	24	30

(a) Explain for the change in temperature in Tube A during the experiment. [1]

---



---

(b) What was the purpose of having Set-up B in the experiment? [1]

---



---

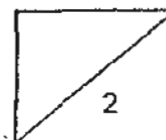

40. Alfred was in an unlit room while Ben was outside, under the sun.

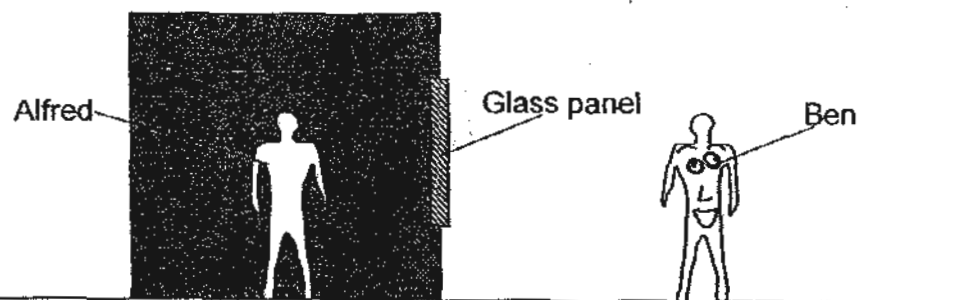

(a) Explain why Alfred could see Ben through the glass panel even though he was in an unlit room. [2]

---

---

(b) The aim of the experiment is to find out which type of glass panel is better to keep the room dim in daytime. Give a reason why when the activity is repeated with a different type of glass panel, the thickness of the glass panel should be kept the same. [1]

---

---

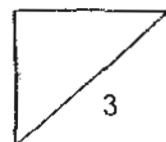

41. The picture below shows a man holding on to a solar airship.

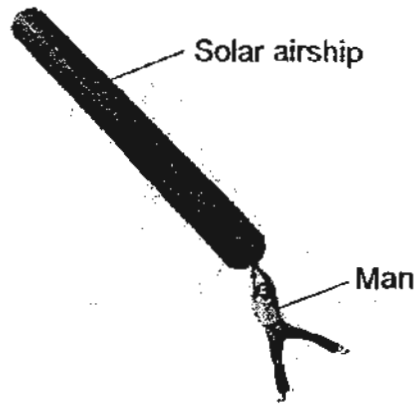

The solar airship is filled with air as the man holds the open end of the tube and walks along with it quickly under the sun. Then, the man will be lifted off the ground as the airship floats in the air.

(a) Explain how the tube floats in the air. [1]

---

---

(b) The outer layer of the solar airship is black. What will be the effect if the layer is changed to white? Give a reason for your answer. [1]

---

---

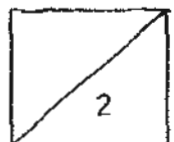

42. The diagram below shows a skateboarder moving down a halfpipe that is made of wood.

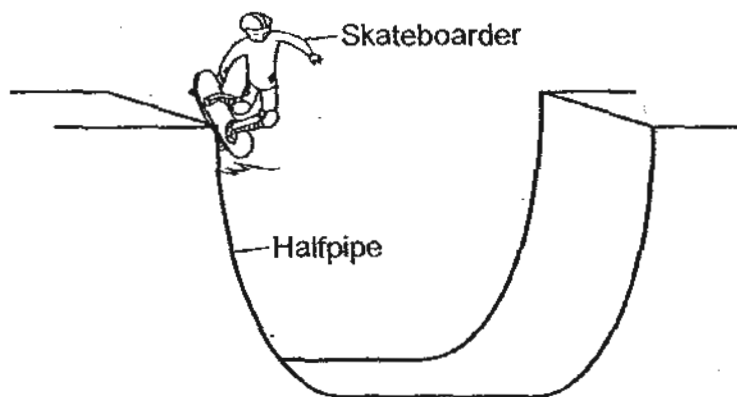

- (a) State the form of energy that the skateboarder possesses when he is stationary on top of the halfpipe. [1]

---

- (b) What is the maximum height the skateboarder can reach on the other side of the halfpipe should he just let himself descend from the top? Mark the position with an "X" in the diagram above and give the reason for your choice. [1]

---

- (c) Besides kicking off from the top of the halfpipe, what could be changed in order for the skateboarder to go higher than height "X" that you have indicated in (b)? [1]

---

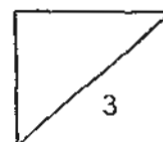

43. Joseph set up an experiment as shown below. He pulled the spring back using the handle and released it so that the spring would hit the ball. He repeated the experiment for different distances the spring was pulled before being released.

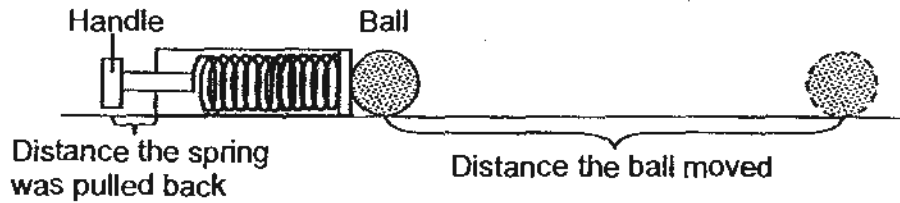

The graph below shows the distance the ball moved with the distance the spring was pulled back.

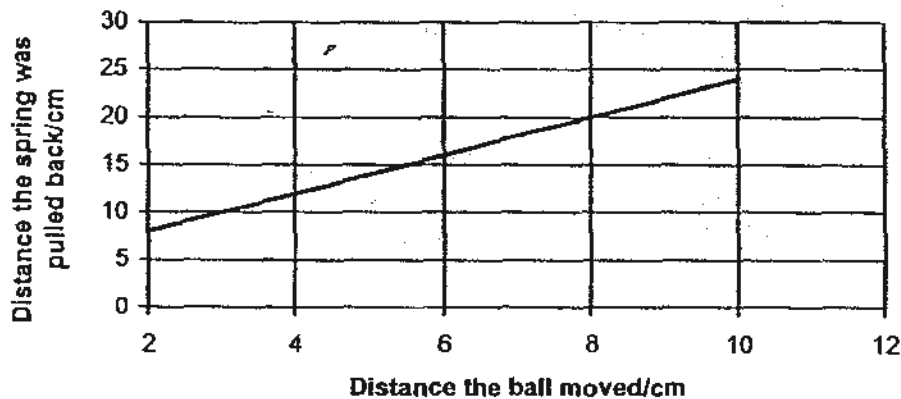

Based on the information given above, answer the following questions.

- (a) State the relationship between the distance the ball moved and the distance the spring was pulled back. [1]
- 
- 
- (b) Predict how far the ball would move if Joseph were to pull the spring back by 12 cm. [1]
- 
- (c) Other than changing the force Joseph could exert on the spring, describe one change that he could make to the set-up if he wanted the ball to move a longer distance. Give a reason for your choice. [1]
- 
- 

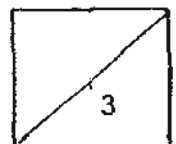

44. The diagram below shows a boy practising archery.

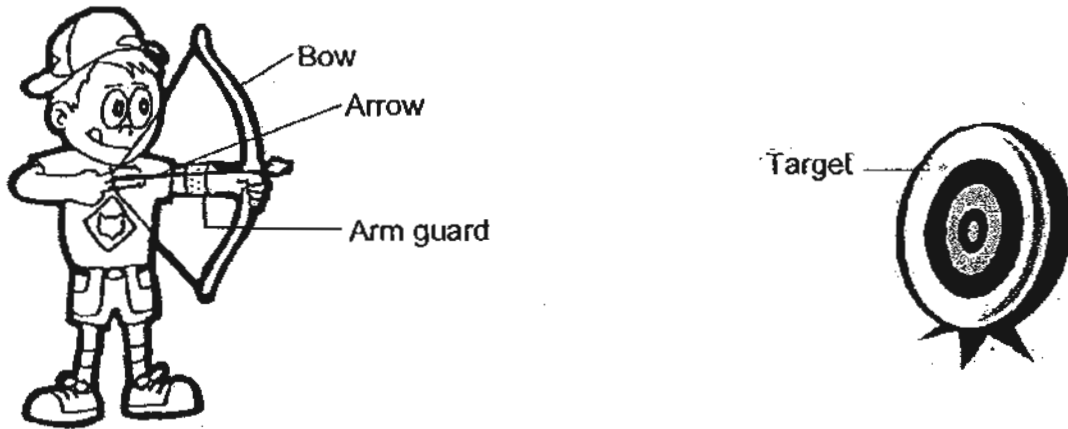

- (a) When the boy releases the arrow, it reaches the target. Draw the path of the arrow from the boy to the target in the diagram above.
- (b) Explain why the path of the arrow you have drawn in (a).

---

---

- (c) If the feathers at the back of arrow are replaced by bigger feathers of the same mass, what must the boy do in order for the arrow to reach the same target? Give a reason for your choice. [2]

---

---

-End of Section B-

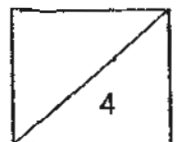

# ANSWER SHEET

EXAM PAPER 2010

SCHOOL : CATHOLIC HIGH PRIMARY  
SUBJECT : PRIMARY 6 SCIENCE

TERM : PERLIMINARY

Q1	Q2	Q3	Q4	Q5	Q6	Q7	Q8	Q9	Q10	Q11	Q12	Q13	Q14	Q15	Q16	Q17
3	1	1	2	4	2	2	2	2	2	4	2	1	2	2	4	3

Q18	Q19	Q20	Q21	Q22	Q23	Q24	Q25	Q26	Q27	Q28	Q29	Q30
2	3	3	2	3	1	4	4	1	3	2	4	3

31)a)The type of cloth used.

b)The brighter the flowers, the greater the number of butterflies that had landed on them.

c)The brighter the colour of the petals, the more pollination it will attract for pollination of the flower. This helps to speed up the process of pollination.

32)a)She is trying to find out whether the amount of elodea in beaker will affect the height of the gas collected in the test tube.

b)

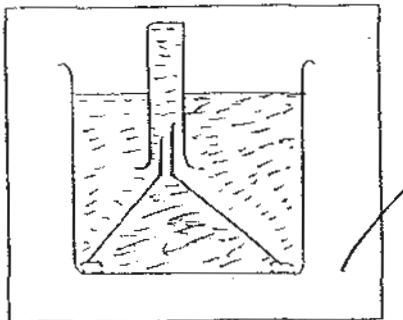

c)To ensure a fair test and to confirm that the height of the gas collect in the test tube is due to the amount of elodea in beaker.

33)a)

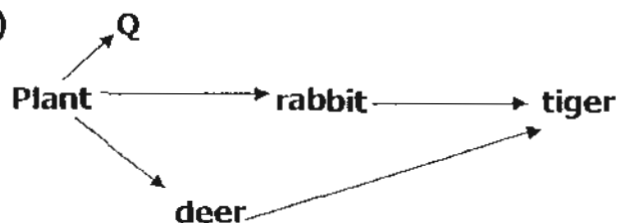

33)b)

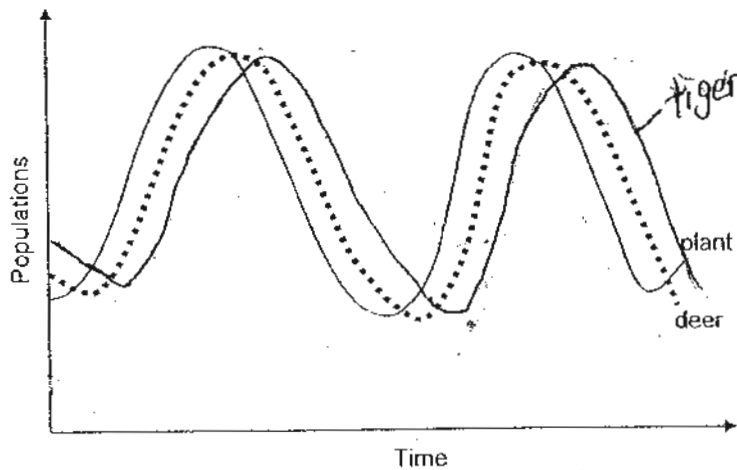

c) There are predators on the deer.

d) The stripes on the body can help the tiger to camouflage in the bushes so the rabbit cannot see the tiger. The hind limbs will help the tiger to run fast and pounce on the rabbit, and eat the prey.

34)a) Time      b) Temperature °C      c) Pond habitat      d) Leaf litter habitat

35) The shrimp is unable to see predators well and relies on the goby to know if there are approaching danger. The goby is unable to burrow into the sand and can live in the shrimp's burrow when it comes out.

36)a) A Murre's egg is structured like a top and can remain on the cliffy terrains without rolling off until it hatches.

b) Since only the seabirds are able to live on this terrains, their predators to harm their offspring.

c) i) Streamlined body.      ii) webbed feet.

37)a) He can conclude that the greater the amount of pesticide sprayed daily on the plants, the lesser the number of aphids left after a week, so the pesticide is very effective of ridding the plants of aphids.

b) Pesticides are chemicals and spraying it on vegetable farms will cause the vegetables to be poisonous, thus when people consume the vegetables, it will poison the people and harm them.

38)a) The mass of the weight.

b) i) Iron. It is the strongest magnetic material which can attract the most magnetic material.

ii) Turn more coils around the magnetic material.

39)a)Water in tray A that was absorbed by the cardboard evaporated into vapour when it gained heat from the air inside the tube.

b)It is used as a control set-up and to find out whether the decreased temperature in Tube A is due to the water poured into the tray.

40)a)Light from outside reflected off Ben and passed through the glass panel to enter Alfred's eyes.

b)If the glass panel is a translucent material, the thickness must be kept the same as it would be opaque if the thickness of the glass panel increases and it would not be a fair test.

41)a)Since the outer layer of the solar airship is black and black is an absorbent of heat, the air in the tube expanded and thus floats in the air.

b)The tube will not float. Black is a better absorbent of heat than white and thus the air in the tube that is covered in white will expand little but it will not float.

42)a)Gravitational potential energy.

b)Some energy is converted to heat and sound energy.

c)Increase the speed of the skateboarder by lubricating the surface of the half pipe.

43)a)As the distance the spring was pulled back increases, the distance moved by the ball increases.

b)4cm.

c)Use a ball of smaller mass or apply lubricant on the surface so as to reduce the frictional force between the ball and surface.

44)a)

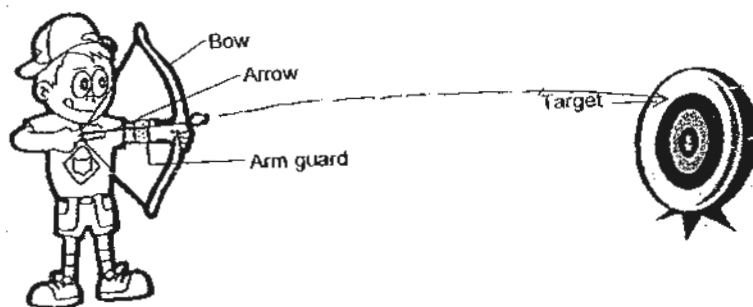

b)Gravity is acting on the arrow all the time.

c)He should stretch the bow more. If he stretched the arrow more, it possessed greater gravitational potential energy and it will be converted into kinetic energy when released and thus it will reach the same target as the bigger feathers will pull the arrow down.