



新加坡福建会馆属下五校小六统一考试

道南 • 爱同 • 崇福 • 南侨 • 光华

SINGAPORE HOKKIEN HUAY KUAN

5-SCHOOL COMBINED PRIMARY 6 PRELIMINARY

EXAMINATION

TAO NAN • AI TONG • CHONGFU • NAN CHIAU • KONG HWA

2010

科学 SCIENCE

BOOKLET A

Date: 27 August 2010

Total Time for Booklets A and B: 1 hour 45 minutes

INSTRUCTIONS TO CANDIDATES

1. Do not open this booklet until you are told to do so.
2. Follow all instructions carefully.
3. Answer all questions.

This booklet consists of 17 printed pages.

School : \_\_\_\_\_  
Name : \_\_\_\_\_ ( )  
Class : \_\_\_\_\_

TOTAL	60
-------	----

**Section A [60 marks]**

For each of the questions numbered 1 to 30, four options are given. One of them is the correct answer. Make your choice (1, 2, 3 or 4) and shade the correct oval on the Optical Answer Sheet.

1. Which of the statements below is true about cells?

- (1) All plant cells have chloroplasts.
- (2) Plant cells have cell wall but not animal cells.
- (3) There are only two types of cells - plant and animal cells.
- (4) An organism grows bigger because its cells grow bigger.

2. Our different body systems are made up of different body parts. Which of the following parts have been correctly classified?

	<b>Skeletal System</b>	<b>Circulatory System</b>	<b>Digestive System</b>
<input checked="" type="radio"/> (1)	Skull	Arteries	Womb
<input checked="" type="radio"/> (2)	Ribcage	Heart	Large intestine
<input checked="" type="radio"/> (3)	Thigh bone	Heart	Windpipe
<input checked="" type="radio"/> (4)	Heart	Blood	Gullet

3. Which of the statements below best describe the functions of a skeletal system?

- A: It supports the body.
- B: It breaks down food into simpler forms.
- C: It enables the exchange of gases with the surroundings.
- D: It works with the muscular system to help us move.

- (1) A and B only
- (2) A and D only
- (3) B and C only
- (4) A, B and D only

4. Which of the following statement(s) is/ are true of the mushroom?

- ~~A~~: The mature spores are carried by the wind to another location.
- ~~B~~: The mushroom reproduces by spores found in between the gills.
- ~~C~~: The mushroom sometimes produces seeds like the flowering plants.
- ~~D~~: The mushroom contains chlorophyll that helps in their reproduction.

- (1) C only
- (2) D only
- (3) A and B only
- (4) A and C only

5. The diagram below shows the life cycle of a mosquito.

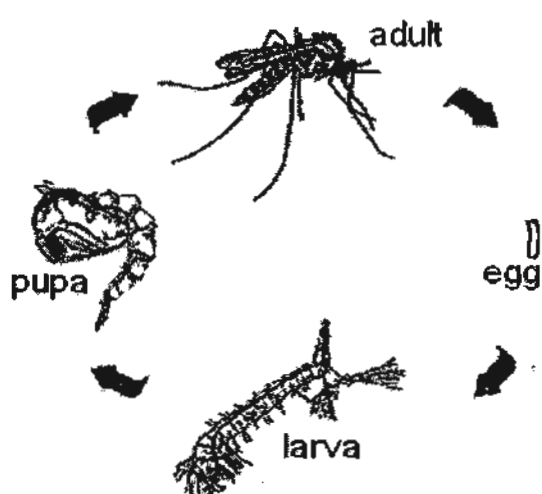

How many stages of its life cycle does a mosquito spend in water?

- (1) 1
- (2) 2
- (3) 3
- (4) 4

6. Study the pictures of the nymphs of the damselfly and the dragonfly below.

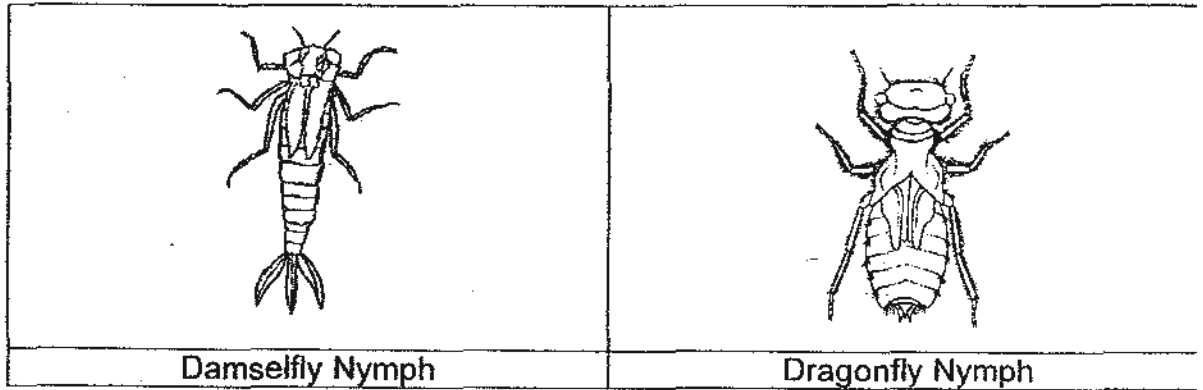

Which nymph can move through water with less resistance? Why?

	<b>Nymph</b>	<b>Reason</b>
(1)	Damselfly	It has 3 tail-like structures.
(2)	Damselfly	It has a streamlined body.
(3)	Dragonfly	It has longer legs.
(4)	Dragonfly	It has a wider body.

7. Four air-tight containers, A, B, C and D, contain some organisms and a chemical solution which turns red when carbon dioxide is present in large quantities.

Container A: 100 water snails kept under light

Container B: 100 water snails kept in the dark

Container C: pondweeds kept under light

Container D: pondweeds kept in the dark

In which of the containers will the chemical solution turn red after a few hours?

- (1) A and C only
- (2) C and D only
- (3) A, B and C only
- (4) A, B and D only

8. Wei Ling's teacher conducted an experiment using the set-up shown below.

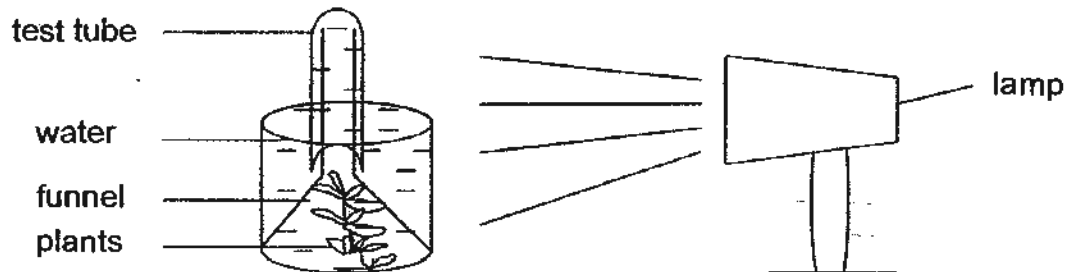

Her teacher repeated the experiment several times with the lamp at different distances from the beaker. What could most likely be the aim of her experiment?

It is to find out how \_\_\_\_\_ affects the rate of photosynthesis.

- (1) light intensity
  - (2) amount of water
  - (3) amount of carbon dioxide
  - (4) temperature of the surrounding
9. Which of the following graphs correctly shows the change in the levels of carbon dioxide and oxygen in the air around some garden plants in the day?

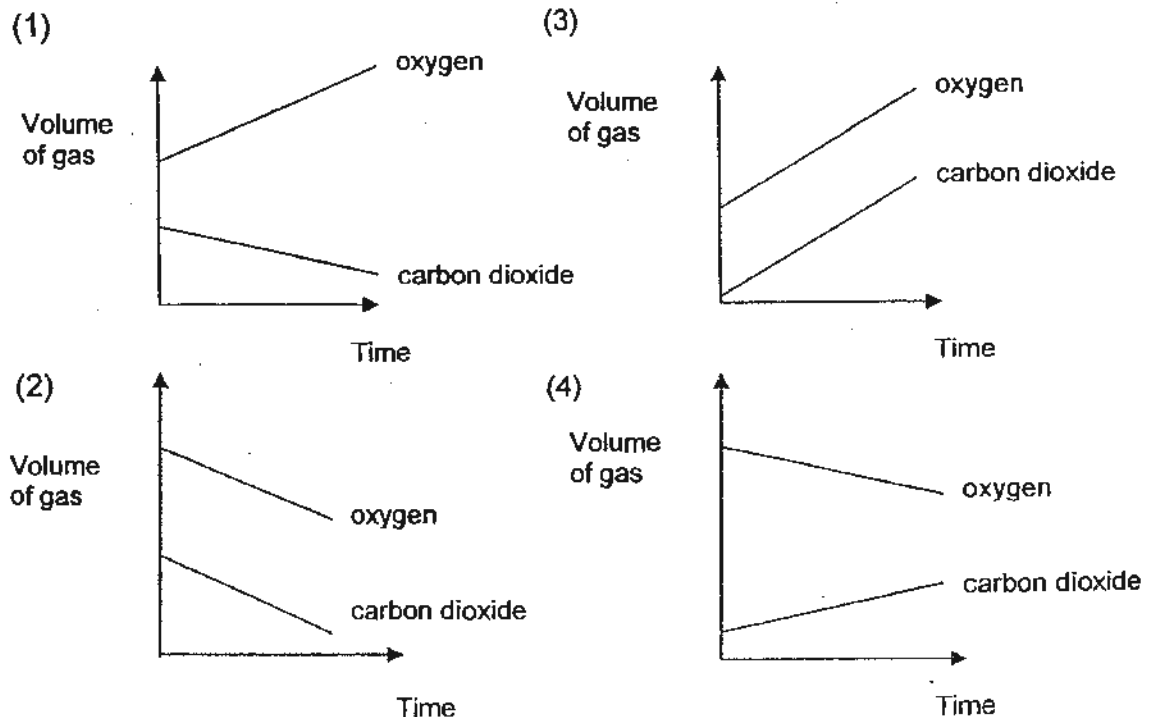

137

10. Study the picture below carefully.

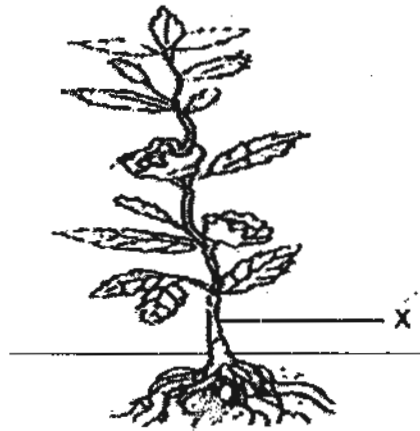

What is/ are the function(s) of part X of the plant?

- A: Anchors the plant firmly to the ground
- B: Transports water from the roots to the other parts of the plant
- C: Transports sugar from the leaves to the rest of the plant
- D: Supports the leaves in order to get as much sunlight as possible

- (1) A only
- (2) A and D only
- (3) B and C only
- (4) B, C and D only

11. The diagram below shows the stages of growth from a bean seed to a young plant.

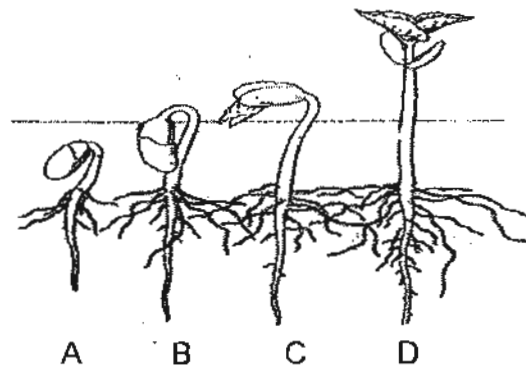

At which stage is sunlight necessary for the seedling to continue to grow?

- (1) A
- (2) B
- (3) C
- (4) D

12. Study the food web below.

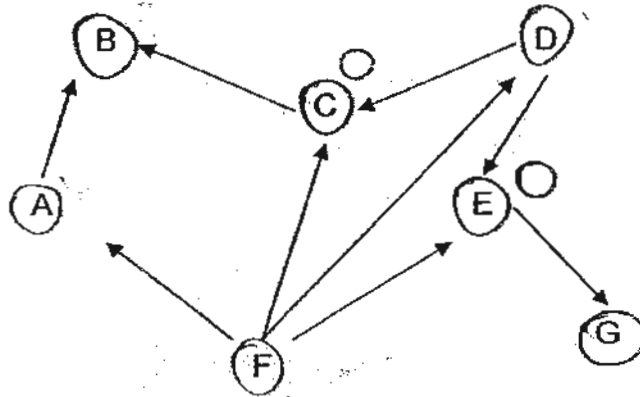

Which of the following is correct about the food web?

	Number of plant-eaters	Number of animal-eaters	Number of plant and animal-eaters
<input checked="" type="checkbox"/>	4	1	1
<input checked="" type="checkbox"/>	2	3	1
<input checked="" type="checkbox"/>	2	2	2
<input checked="" type="checkbox"/>	3	2	2

13. A company is mindful of the impact its products have on the environment. Which of the following measures could the company take to be environmentally friendly?

- A. Using materials that are biodegradable
- B. Using renewable energy sources to power its plants
- C. Designing products that are as energy efficient as possible
- D. Designing packages that save space during transportation

- (1) A and B only
- (2) C and D only
- (3) A, C and D only
- (4) A, B, C and D

14. Ming Jun collected four beakers of water from four different rivers, P, Q, R and S. Using the set-up below, he measured the amount of light that passed through each beaker of water using a light sensor.

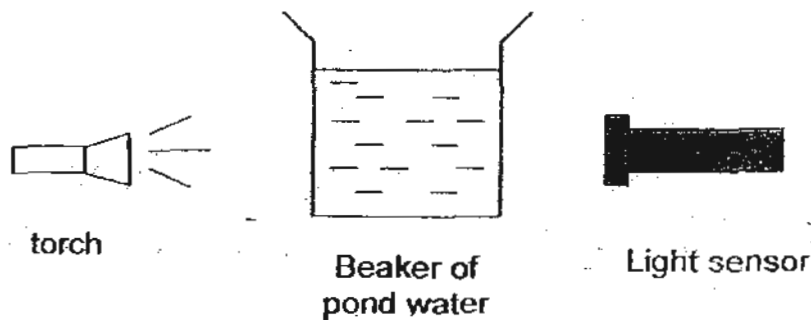

He then plotted a graph based on the amount of light recorded by the light sensor.

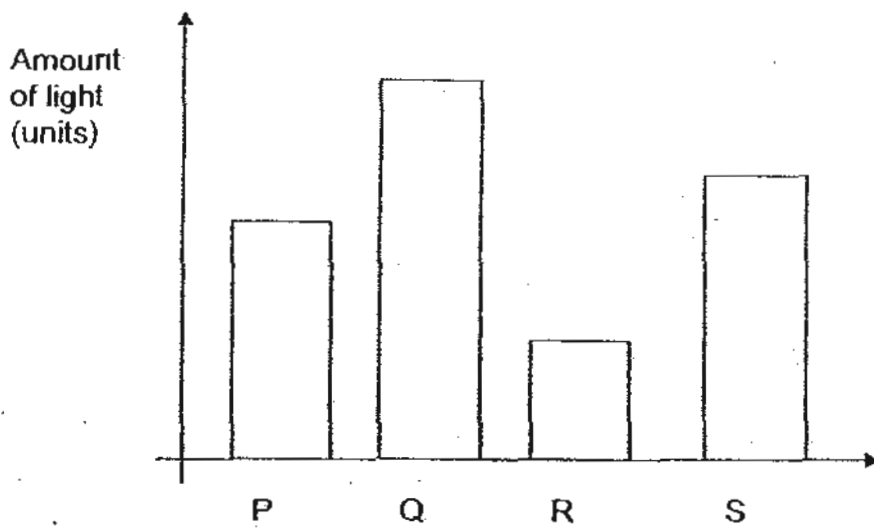

Which river would most likely have the greatest number of plants and animals?

- (1) P
- (2) Q
- (3) R
- (4) S

15. The diagram below shows Mr Lim's family tree. A shaded square or circle represents a family member with Thalassaemia, a blood disease that is inherited.

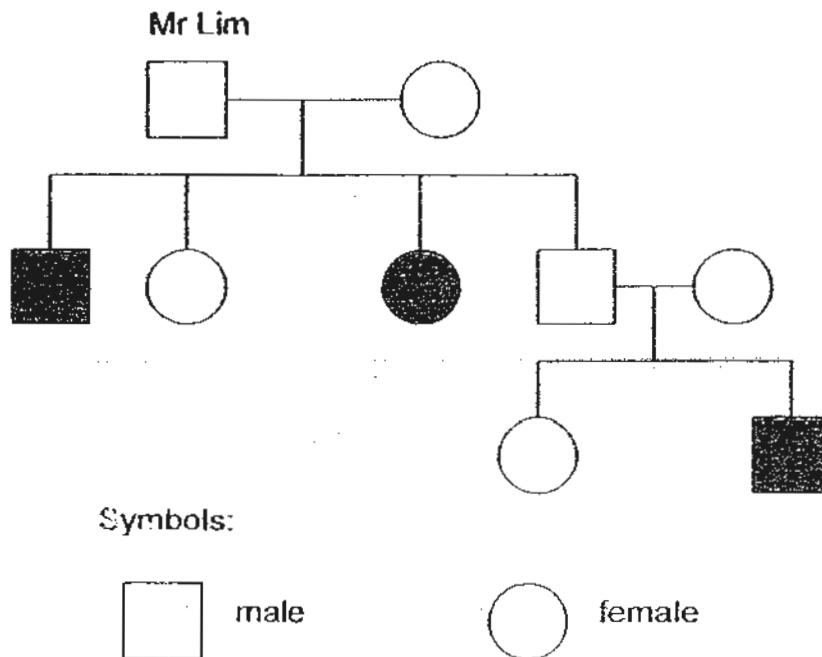

How many of Mr Lim's sons is/are suffering from Thalassaemia?

- (1) 1  
 (2) 2  
 (3) 3  
 (4) 4
16. The recent oil spill that happened in the Gulf of Mexico has seriously affected seabirds that lived in the area of water near the seashore. Many seabirds were discovered dead on the beach. Which of the following reasons are likely causes for the death of these seabirds?
- A: The oil caused the seabirds to suffocate and die.  
 B: The seabirds ate the fish which were poisoned by the oil.  
 C: The seabirds' feathers were coated with oil which prevented the birds from flying and hence drowned.
- (1) A only  
 (2) A and B only  
 (3) B and C only  
 (4) A, B and C

17. The diagram below shows two drivers approaching from opposite ends of a row

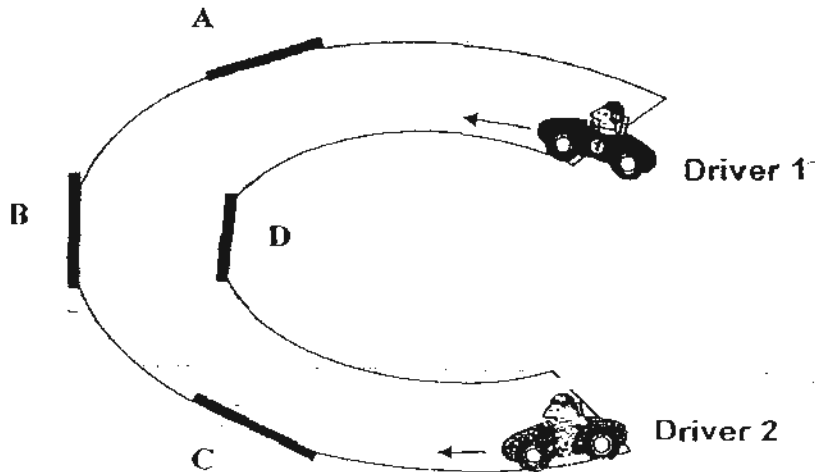

At which position, A, B, C or D, should the mirror be placed in order for both drivers to have a good view of approaching vehicles?

- (1) A
- (2) B
- (3) C
- (4) D

18. A group of pupils carried out an experiment to study the factors that affect the rate of evaporation. They recorded the conditions in the table below.

Set-up	Exposed surface area of water (cm <sup>2</sup> )	Temperature of water (°C)	Amount of water used (ml)
A	40	80	150
B	50	50	200
C	50	80	200
D	60	50	150

Which two set-ups should be used to make a comparative study of their results order to form a correct conclusion?

- (1) A and B
- (2) A and D
- (3) B and C
- (4) B and D

19. <sup>Three</sup> ~~Four~~ beakers, P, R and S, were filled with different substances. The beakers were then left on the table in the Science Laboratory.

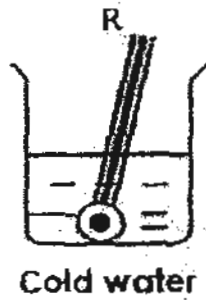
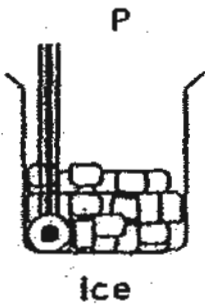

Which of the following shows the temperature of the three substances ranging from the lowest to the highest?

- (1) P, R, S
  - (2) P, S, R
  - (3) R, P, S
  - (4) S, R, P
20. The diagram below shows a mug.

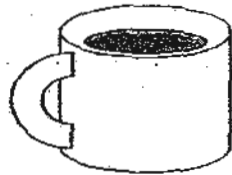

When a torch is shone on the mug at different angles, which of the following shadows below can be formed?

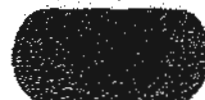
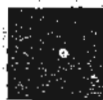

- (1) B and D only
- (2) A and E only
- (3) A, C and E only
- (4) B, C and D only

21. A glass of hot tea is put into a basin of cold water as shown in the diagram below.

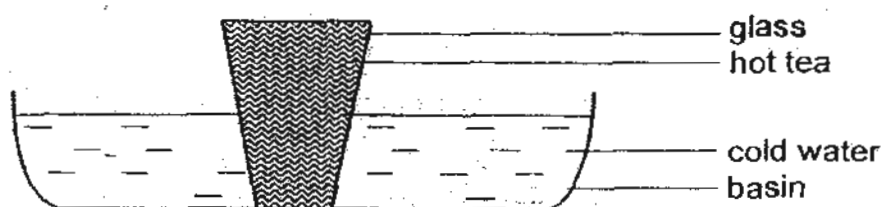

The line graph below shows the changes in the temperature of the hot tea and cold water. Which lines could represent the temperatures of the hot tea and cold water respectively?

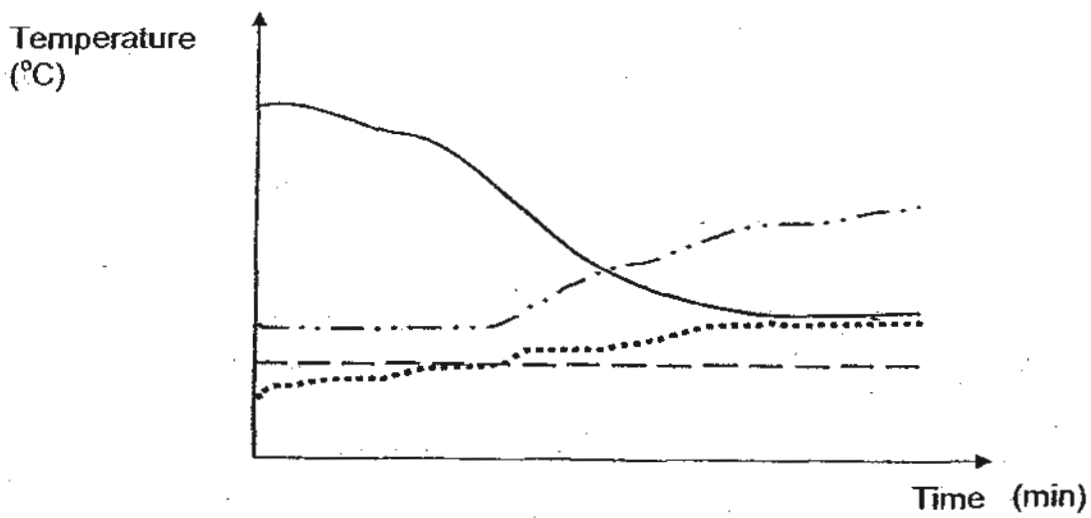

Line A	—————	Line C	- - - - -
Line B	- · - · -	Line D	· · · · ·

- (1) Line A and Line B
- (2) Line A and Line D
- (3) Line B and Line C
- (4) Line B and Line D

22. Study the diagram shown below.

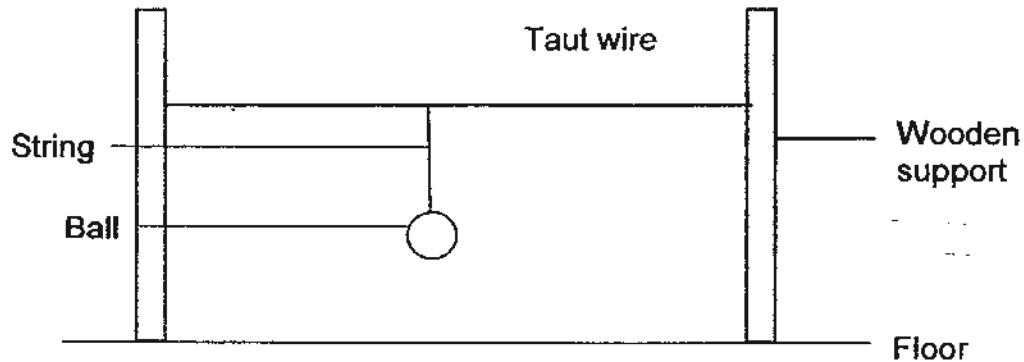

What happens when the wire is heated for some time?

- A. The wire expands.
- B. The string extends.
- C. The wire remains stretched tightly.
- D. The ball moves lower towards the floor.

- (1) A and B only
- (2) A and D only
- (3) A, B and C only
- (4) B, C and D only

23. The diagram below traces the path of a ball in motion as it was thrown in the air.

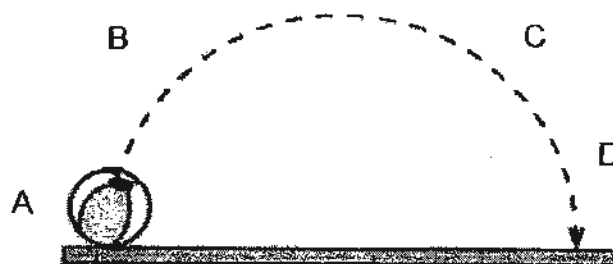

At which points does the ball have **both** potential and kinetic energy?

- (1) A and B only
- (2) A and C only
- (3) B, C and D only
- (4) A, B, C and D

24. Melissa held a bar magnet above a paper clip tied to a weight by a string. The magnet pulled the paper clip up. When she placed a sheet of metal between the magnet and the clip, the clip remained lifted.

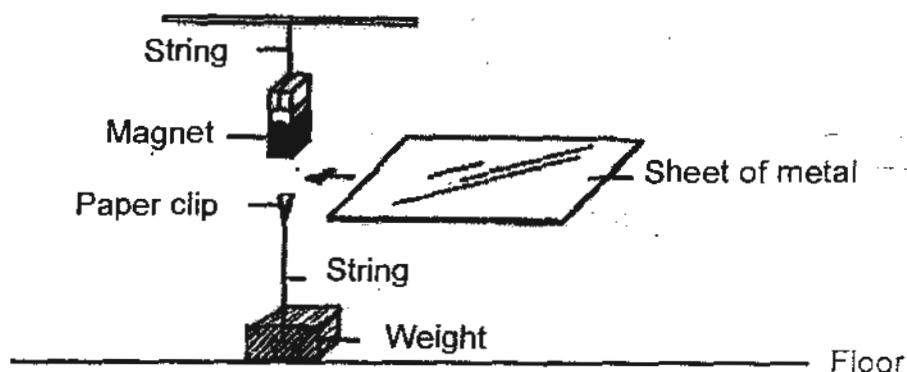

Melissa concluded that the \_\_\_\_\_

- (1) paper clip was magnetized
  - (2) sheet of metal became a magnet
  - (3) sheet of metal was made of a magnetic material
  - (4) magnetic force could pass through the sheet of metal
25. Ellen placed a ruler at the edge of the table and held it down firmly with her hand. Placing an eraser on the other end of the ruler, Ellen pressed the ruler down and then let go of the eraser.

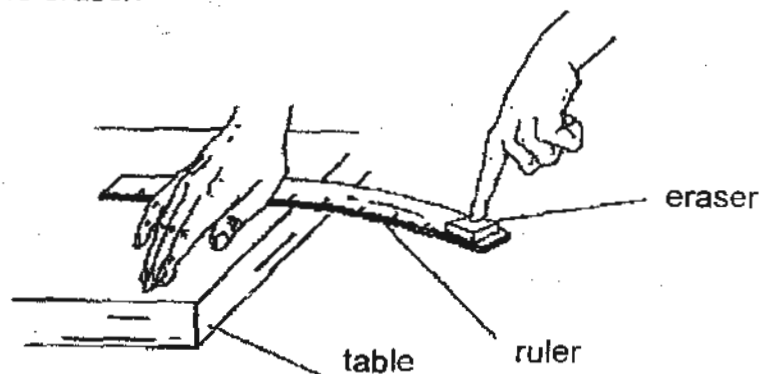

She observed that the eraser was thrown off the ruler. Where did the eraser obtain its energy from?

- (1) From the bent ruler
- (2) From the air surrounding the eraser
- (3) From the masses of the ruler and the eraser itself
- (4) From the hand that was holding the ruler down

26. The diagram shows a thin plastic table with four objects, W, X, Y and Z, placed side by side on the table top. The objects are of the same mass.

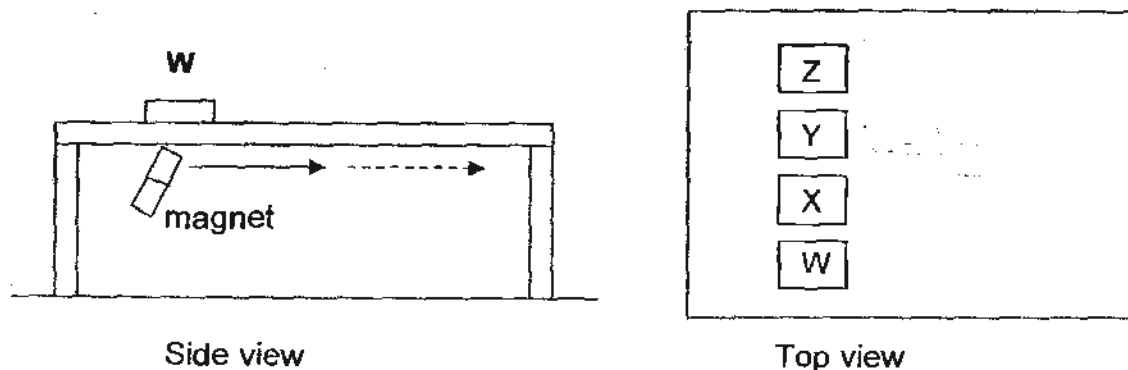

A strong magnet was placed under each object in turn and dragged below the table top for a short distance.

The objects used are an aluminium can, a steel rod, an iron plate and a silver disc. If object Y is the iron plate and object X is the silver disc, which one of the following shows the correct recorded results?

	Moved together with the magnet	Did not move with the magnet
<input checked="" type="checkbox"/>	Y only	X, W and Z
<input checked="" type="checkbox"/>	X and Y	W and Z
<input checked="" type="checkbox"/>	Y and W	X and Z
<input checked="" type="checkbox"/>	X, Y and Z	W

27. Sarah set up the experiment as shown below. The block would be released at the same point at the top of the ramp.

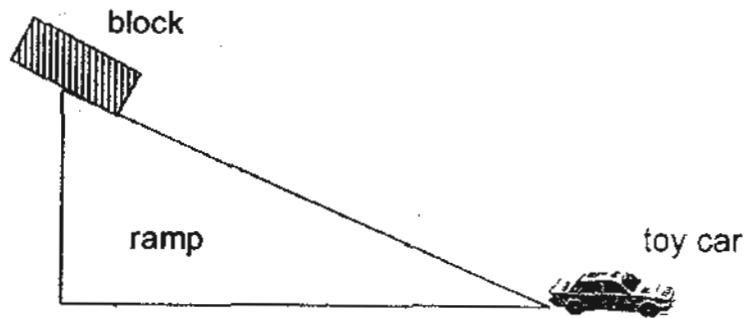

She wanted to find out if the mass and the texture of the block would affect the distance moved by the toy car. She was given four blocks as shown below.

<div style="border: 1px solid black; width: 60px; height: 30px; margin: 0 auto;">P</div>	<div style="border: 1px solid black; width: 60px; height: 30px; margin: 0 auto;">Q</div>
Surface texture : rough Mass : 40 g	Surface texture : rough Mass : 80 g
<div style="border: 1px solid black; width: 60px; height: 30px; margin: 0 auto;">R</div>	<div style="border: 1px solid black; width: 60px; height: 30px; margin: 0 auto;">S</div>
Surface texture : smooth Mass : 80 g	Surface texture : smooth Mass : 100 g

Sarah decided to choose three out of the four blocks to conduct her experiment. Which of the three blocks could she use?

- A. P, Q and R
  - B. P, R and S
  - C. Q, R and S
  - D. P, Q and S
- (1) A only  
 (2) A and C only  
 (3) B and C only  
 (4) B and D only

28. Block M is a bar magnet. It was placed on a glass table as shown below. A copper block was attached to the bottom of the table. Block M was given a push to move along the table.

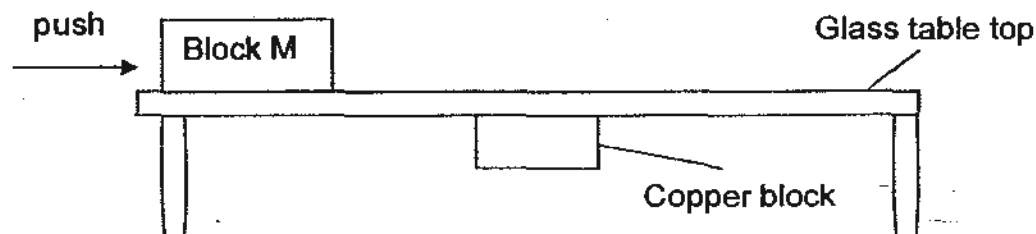

The following are the different types of forces that can act on an object:

- P: Magnetic force  
 Q: Gravitational Force  
 R: Frictional Force

Which of the above force(s) must the push overcome in order for Block M to move along the table?

- (1) R only  
 (2) P and R only  
 (3) Q and R only  
 (4) P, Q and R
29. Four cups, A, B, C and D, made of different materials, were filled with the same amount of boiling water and placed on the table for an hour. The initial temperature of the water was the same, at 100°C. The final temperature of the water in the four cups was recorded as shown in the table below.

Cup	Final Temperature
A	83°C
B	57°C
C	61°C
D	76°C

How would you classify the cups according to their conductivity in heat?

	Good conductors of heat	Poor conductors of heat
<input checked="" type="checkbox"/>	A and B	C and D
<input checked="" type="checkbox"/>	A and D	B and C
<input checked="" type="checkbox"/>	B and C	A and D
<input checked="" type="checkbox"/>	C and D	A and B

30. The diagrams below compare how much four strips of materials joined together expand when heated.



Before heating

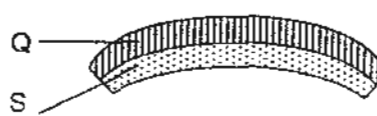

After heating

Based on the diagrams, arrange the four materials beginning with the one that expands the most.

- P, Q, S, R
- R, S, Q, P
- R, P, Q, S
- S, Q, P, R

##### END OF BOOKLET A #####



新加坡福建会馆属下五校小六统一考试

道南 • 爱同 • 崇福 • 南侨 • 光华

**SINGAPORE HOKKIEN HUAY KUAN**

**5-SCHOOL COMBINED PRIMARY 6 PRELIMINARY**

**EXAMINATION**

**TAO NAN • AI TONG • CHONGFU • NAN CHIAU • KONG HWA**

**2010**

**科学 SCIENCE**

**BOOKLET B**

**Date: 27 August 2010**

Total Time for Booklets A and B: 1 hour 45 minutes

**INSTRUCTIONS TO CANDIDATES**

4. Do not open this booklet until you are told to do so.
5. Follow all instructions carefully.
6. Answer all questions.

This booklet consists of 14 printed pages.

School : \_\_\_\_\_  
Name : \_\_\_\_\_ ( )  
Class : \_\_\_\_\_

TOTAL	40
-------	----

**Section B [40 marks]**

Write your answers to Questions 31 to 44 in the spaces provided.

31. The diagram below shows a female flower.

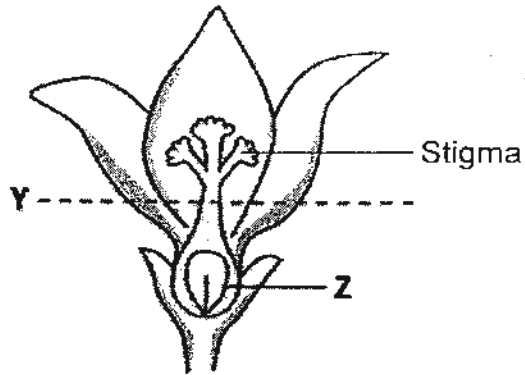

As part of an experiment, Paul dusted some pollen grains onto the stigma of the flower to pollinate it. After three days, he cut the flower at Y.

(a) What will then happen to part Z if the flower is still growing on the plant? [1]

---

---

---

---

32. Study the diagram below that shows a human digestive system.

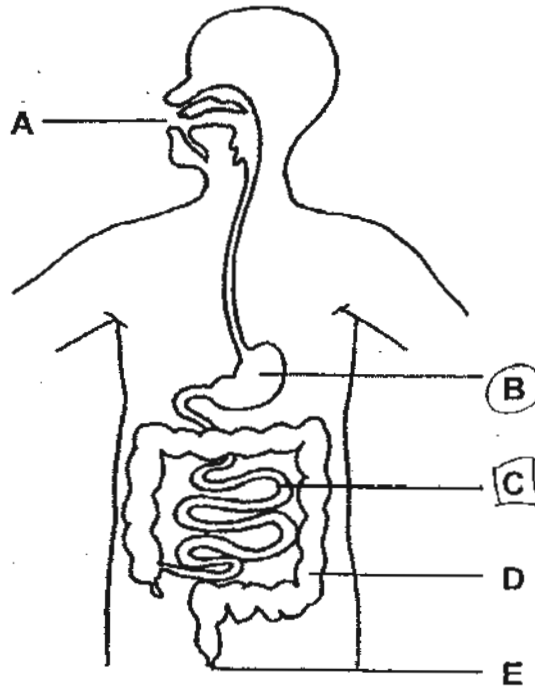

(a) At which point does digestion start? [1]

---

(b) Name the organ at point B. [1]

---

(c) State one function of the organ at point C. [1]

---

---

---

33. The diagram below shows the food relationship within a pond community.

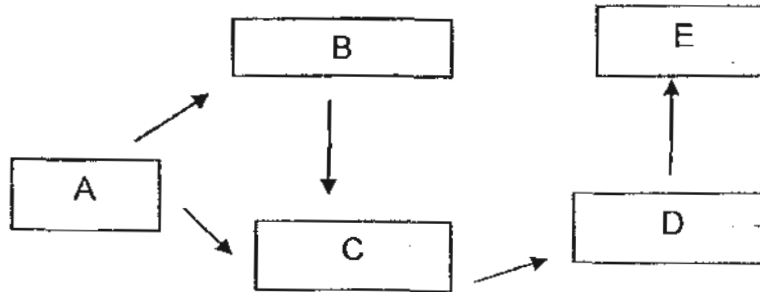

- (a) Based the food web, arrange the following organisms in the pyramid shown below. The pyramid is a diagram which shows the population sizes of the organisms in a community. [2]

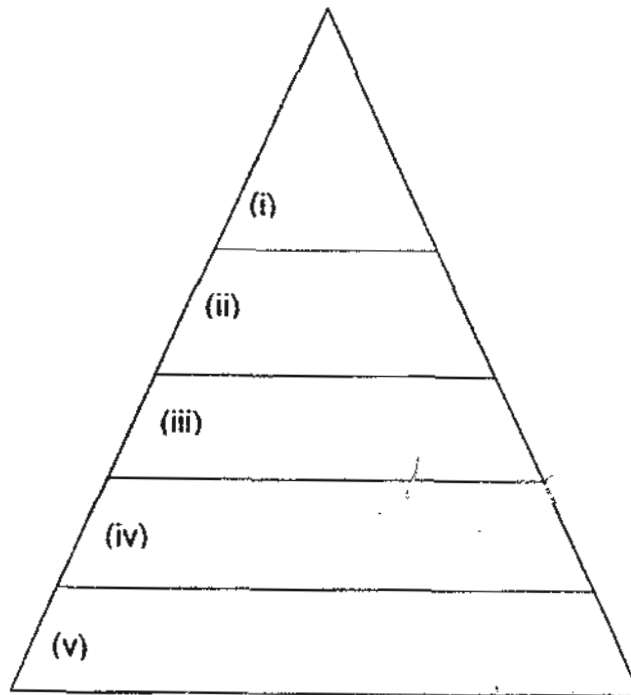

- (b) How would a decrease in the population of C affect the population of E? Explain your answer. [2]



---

---

---

---

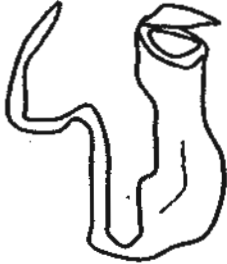
34. Animals and plants have developed certain behavioural or structural adaptations. Complete the table below to explain how their adaptations have helped them to survive. [3]

Name of organism	Adaptations	How the adaptations help them to survive
<p>A sloth on a tree</p> 	<p>Moves very, very slowly and spends most of its time hanging upside down from trees</p>	
<p>A Pitcher Plant</p> 	<p>Has sweet smelling nectar in the pitcher and leaves that form a pitcher with slippery sides</p>	
<p>A Humming Bird</p> 	<p>Has a long beak that can reach deep into flowers</p>	

35. John's parents bought a new house in Tampines and they would be moving into the new house soon. The windows of their new living room faced the West. Thus, John's parents said that it would be very hot in the afternoon when the Sun set. Luckily, the windows of their new house were double-glazed. The diagram below shows the side view of a double-glazed window, which consists of the outer and inner glass panels separated by a thin layer of air.

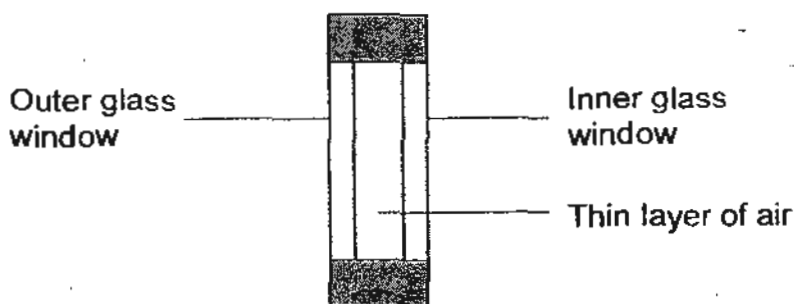

The graph below shows how the temperature in the living room would vary without the double-glazed windows.

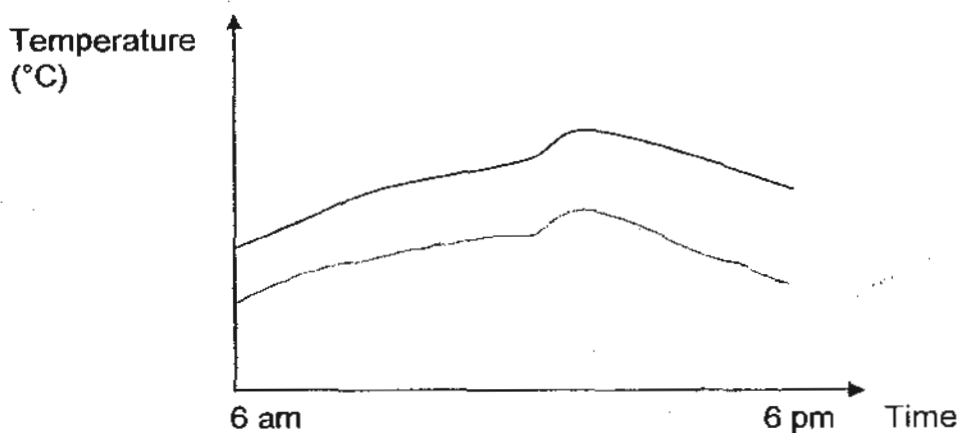

- (a) Draw another line in the graph above to show how the temperature in the living room would vary with the double-glazed windows. [1]
- (b) Explain your graph in (a) above. [1]

---



---



---

(c) In winter, some birds puff up their feathers, as shown in the diagram below.

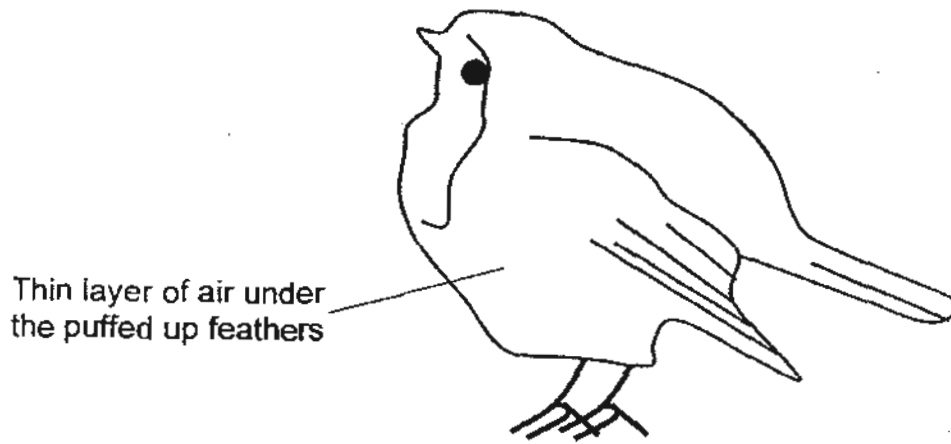

Why do you think birds puff up their feathers in winter? [1]

---

---

36. Man has been clearing huge areas of forests to make way for urban development. This has led to negative effects which prompted international efforts to reduce this human activity.

State two positive impacts of the conservation of forests. [2]

(a) 

---

---

(b) 

---

---

37. Ian has 4 magnets of different sizes, labelled A, B, C and D as shown below.

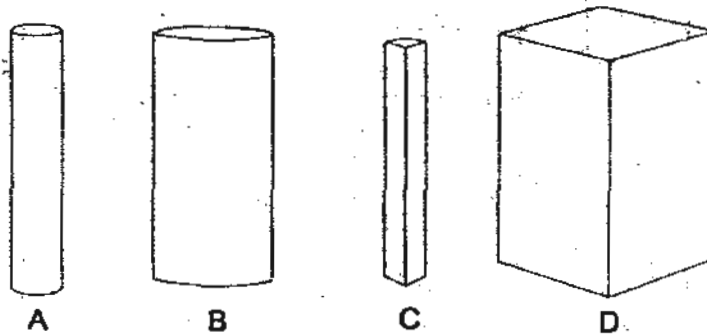

To compare the strength of the magnets, he brought each of the magnets near some pins.

The table below shows the number of pins attracted by the magnets, A, B, C and D, from the various distances.

Magnet	Distance between magnet and pins (cm)	Number of pins attracted
A	5	10
B	4	11
C	6	11
D	4	10

(a) Which magnet is probably the strongest? Give a reason for your answer. [1]

---

(b) Based on the experiment, what can you conclude about magnetic force and the size of magnet? [1]

---

(c) Suggest what Ian can do to confirm that the magnet that he chose in (a) is the strongest. [1]

---



---



---

39. Melvin is a farmer. He found that his crops were badly affected by a certain kind of pest. However, his crops were also visited by honey bees which are considered useful.

The graph below shows the number of honey bees that visited his crops from 8 am to 8 pm on a certain day.

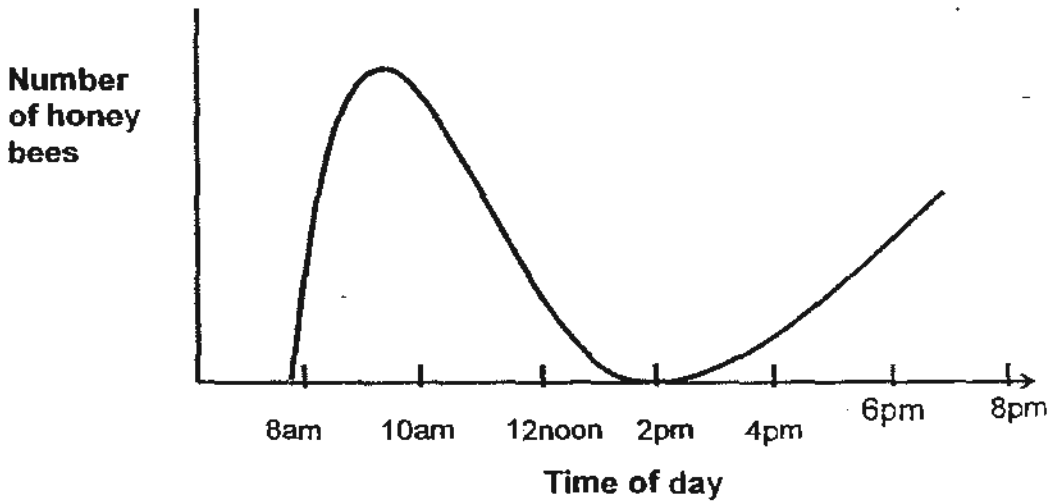

- (a) When would be the best time to spray the crops with pesticide to get rid of the pests but at the same time minimise the number of honey bees being killed? [1]

- (b) The farm was located next to a river as shown in the diagram below.

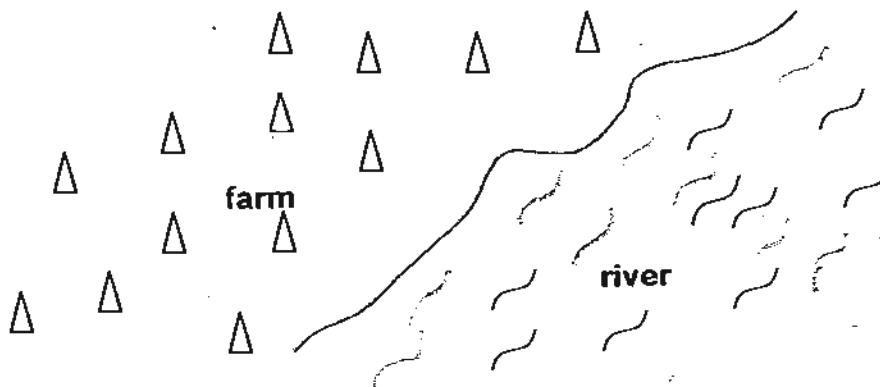

Explain how spraying pesticides might lead to water pollution. [1]

38. Timothy carried out an experiment in a dark room with the set-up as shown in the diagram below. He arranged four sheets made of different materials, W, X, Y, Z, in a straight line. When only the torch was switched on, Timothy observed that a bright patch of light was seen on Sheet Y only.

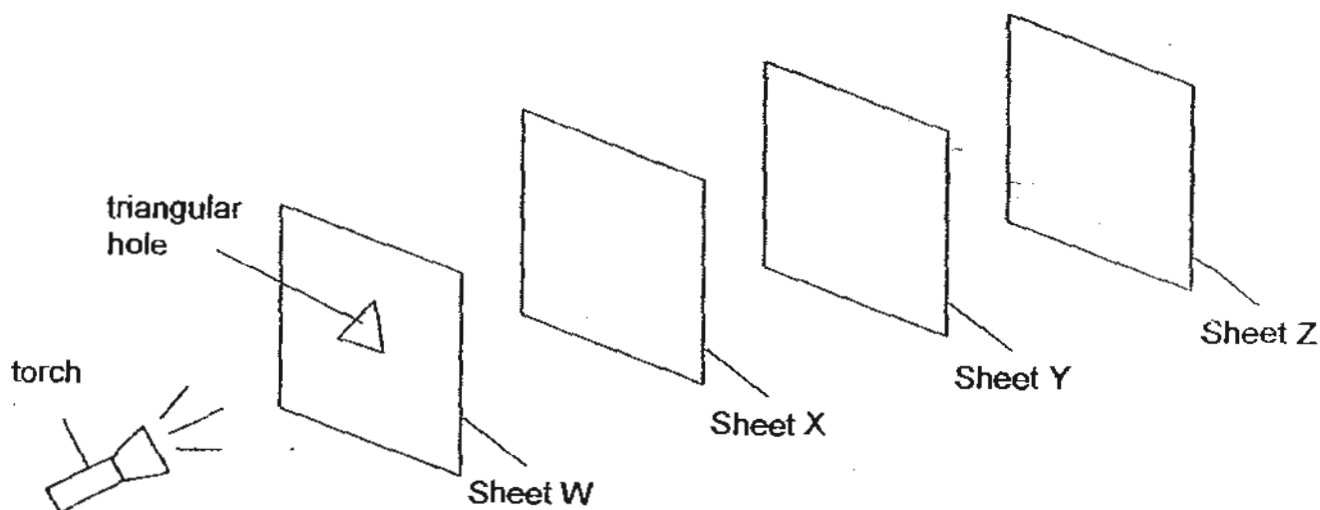

- (a) From Timothy's observation, describe the property of Sheet Y. [1]

---

- (b) Draw the patch of light formed on Sheet Y below. [1]

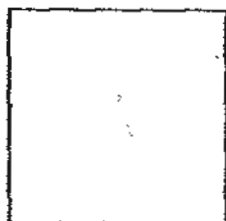

- (c) Explain how the patch of light was formed on Sheet Y. [1]

---

---

- (d) What would happen to the patch of light when the torch was moved further away from Sheet W? [1]

---

40. Sally placed Basketball X at point A and Basketball Y at point C. She pushed the Basketball X at point A and it rolled down the slope towards point C.

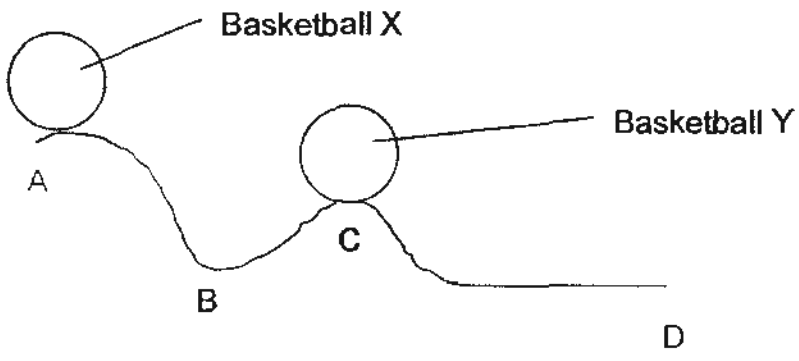

- (a) What would happen to Basketball Y at point C when Basketball X that was rolling hit it? [1]

---

- (b) What energy change occurred in Basketball Y at point C when it was hit by rolling Basketball X? [1]

---

- (c) What caused Basketball Y to eventually stop rolling? [1]

---

---

---

41. Sally heated some water in a beaker at room temperature till it boiled.

The beaker of water was then left on the kitchen table to cool. She recorded the results in the graph shown below.

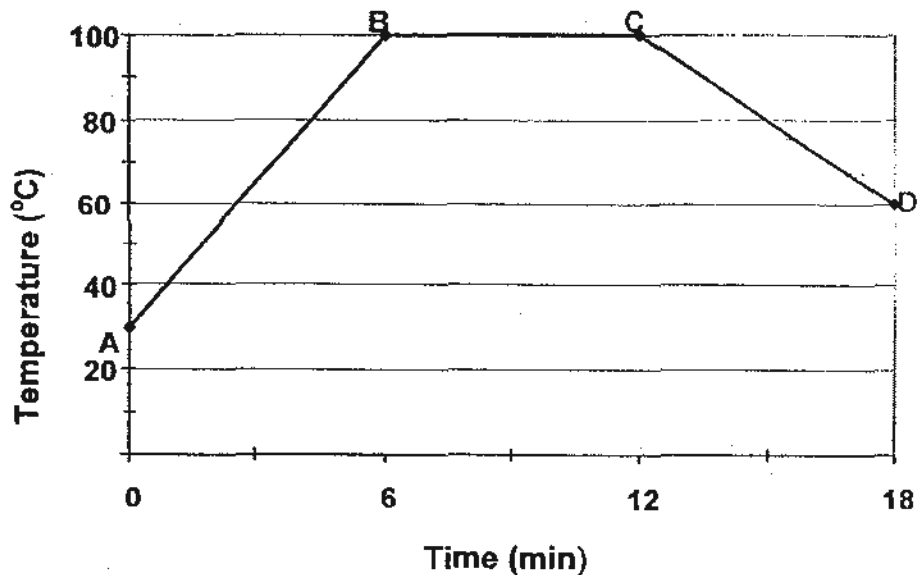

Below are 4 sentences based on the results. Indicate whether each of the statements is True, Not True or Not possible to Tell by putting a tick ( $\checkmark$ ) in the correct box. [2]

Statements	True	Not True	Not possible to tell
Water boiled for 12 minutes.			
The water heats up faster than it cools down.			
A constant amount of heat was supplied to the beaker from A to C.			
Water was added during the period CD.			

42. Glenn was given four objects, as shown in the box below, by his Science teacher. He was supposed to classify them into two groups according to whether they float or sink.

A fifty-cent coin	An empty capped plastic bottle
An eraser	A coconut

- (a) Help Glenn classify the objects by completing the classification table given below. [2]



- (b) From the classification table above, you have identified some object(s) that can float. Give a reason why the object(s) are able to float.

[1]

---

---

---

43. Study Circuit A which is not drawn to scale.

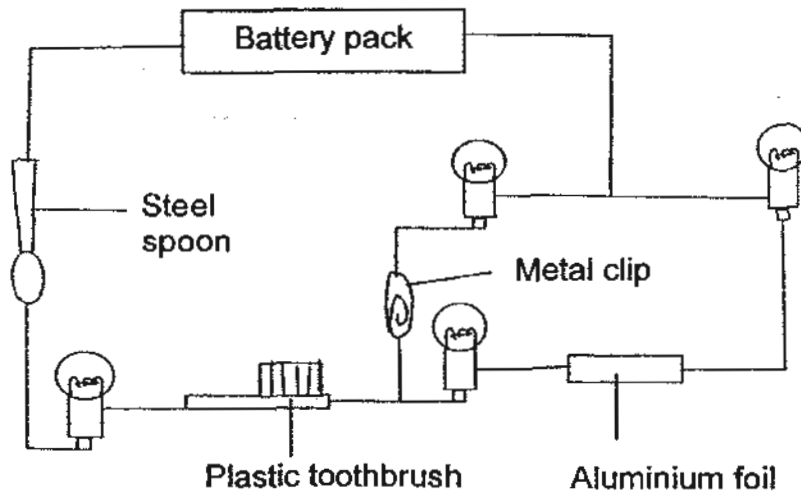

**Circuit A**

(a) How many bulb(s) will light up?

[1]

(b) In Circuit B shown below, the positions of the metal clip, plastic toothbrush and aluminium foil are rearranged. Write in the boxes provided "metal clip", "plastic toothbrush" and "aluminium foil" such that the most number of bulbs could be lit. [2]

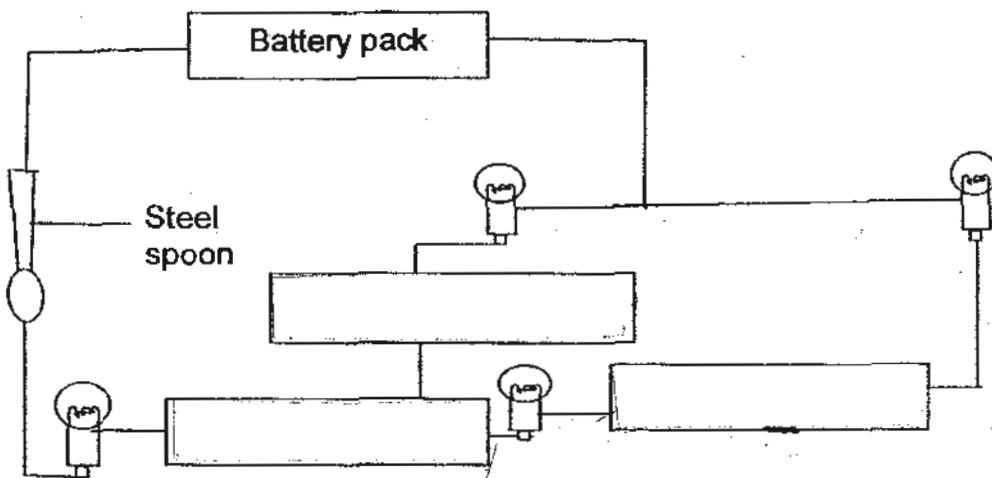

**Circuit B**

44. Michelle made a toy tortoise by fixing a ball of plasticine to the rubber band inside a polystyrene foam cup.

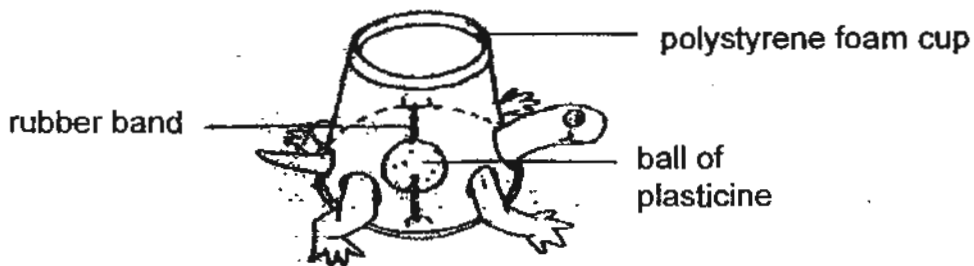

She placed the tortoise on the table, rolled it backwards and released it. She then measured the distance travelled by the tortoise. Next, she used a bigger ball of plasticine and repeated the experiment.

- (a) Explain why the tortoise was able to move on its own after it was released. [1]

---

---

- (b) What was the aim of her experiment? [1]

---

---

- (c) Which two variables must she keep constant to ensure a fair test? [1]

---

---

---





Singapore Hokkien Huay Kuan 5 School Combined Primary 6 Prelim Exam 2010  
Science

Booklet A

1. 2	7. 4	13. 4	19. 1	25. 1
2. 2	8. 1	14. 2	20. 1	26. 3
3. 2	9. 2	15. 1	21. 2	27. 2
4. 3	10. 4	16. 3	22. 2	28. 1
5. 3	11. 3	17. 2	23. 3	29. 3
6. 2	12. 3	18. 3	24. 4	30. 3

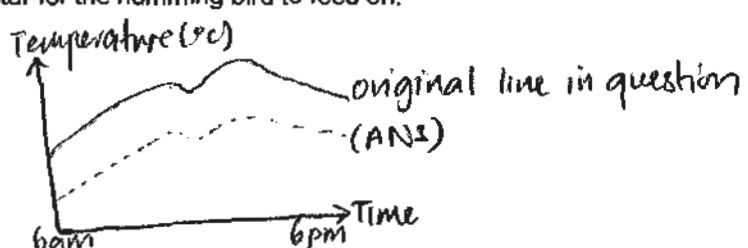
Booklet B

31. (a) Part Z will be pollinated and develop into a fruits with seeds for reproduction.  
(b) This is because during pollination, the pollen grains will be attracted onto the stigma and these pollen grains would enter and fertilise the ovules represented by part z.
32. (a) A  
(b) Stomach  
(c) Point C is where digestion stops and nutrients are being absorbed into the bloodstream.
33. (a) (i) E (ii) D (iii) C (iv) B (v) A  
(b) Yes. The decrease in population c will affect population D as the supply of food for D decreases. When the population of D decreases, the population of E will also decrease as E have lesser D to feed on.
34. Sloth: Sloth eats only leaves that are naturally low in energy and hard to digest. Their lethargic movements help them to conserve the little energy they get from their diet.  
Pitcher Plant: Insects will be attracted to the pitcher plant and when they fly into the pitcher plant, the slippery sides will cause them to fall into it. They will then decompose to become nutrients for the pitcher plant when the pitcher plant did not get enough nutrients from the soil.  
Humming Bird: The long beak helps the humming bird to reach deep into the flower for nectar for the humming bird to feed on.
35. (a)   
(b) Since there is a larger air trap between the inner and outer layer of the window, lesser heat will enter the house as air is an insulator of heat.  
(c) As air is an insulator of heat, birds puff up their feather to keep them warm in winter.
36. (a) Less trees are being cut down and less heat will be trapped as trees take in carbon dioxide and gives out oxygen when it photosynthesis.  
(b) Human will not lose some important medicines from some trees that were in the forest.
37. (a) C. It attracted the most number of pins although the distance between the pins and the magnet is the furthest.  
(b) The size of the magnet does not affect the magnetic force.  
(c) Repeat the experiment by keeping the distance between the magnets and pins to be constant for all attempts.
38. (a) Sheet Y is opaque and does not allow light to pass through it.  
(b) 

END

1/67

- (c) The light from the torch pass through the triangular hole and through transparent Sheet X and then formed a patch of light on opaque Sheet Y.  
 (d) It would remain the same.

39. (a) 2 pm  
 (b) The insecticide could be water soluble and when it rains, or there are excess water used to water the plants on the farm, these excess water will contain the dissolved insecticides and be washed away into the river to pollute the river.

40. (a) Basketball. Y will roll down part C towards D.  
 (b) Gravitational potential energy is being converted to kinetic energy for basketball Y to move.  
 (c) Friction.

41. not true, true, not possible to tell, not possible to tell

42. (a)

Float	Sink
An empty capped plastic bottle	A fifty cent coin
A coconut	An eraser

(b) The objects can float because the air trapped in the plastic bottle cap due to its structure and the coconut husk helps these objects to be buoyant and float.

43. (a) No bulb will light up.  
 (b)

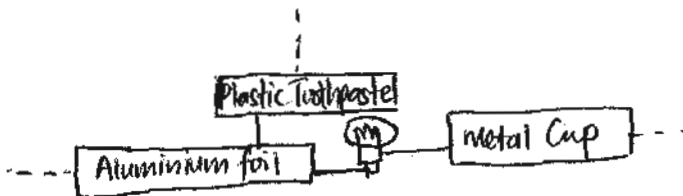

44. (a) Elastic potential energy from the rubber band is converted to kinetic energy of the ball of plasticine, enabling the tortoise to move.  
 (b) To find out if the size of the ball of plasticine affects the distance moved by the toy tortoise.  
 (c) The distance rolled backwards (i.e. how much the rubber band was stretched) and the same toy tortoise.