

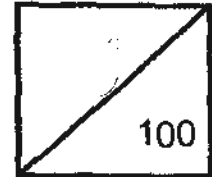

Rosyth School
Preliminary Examination for 2010
STANDARD SCIENCE
Primary 6



Name: _____

Total
Marks:

Class: Pr 6 _____

Register No. _____

Duration: 1 h 45 min

Date: 26th August 2010

Parent's Signature: _____

Booklet A

Instructions to Pupils:

1. Do not open the booklet until you are told to do so.
2. Follow all instructions carefully.
3. This paper consists of 2 Parts, Part I and Part II.
4. For questions 1 to 30 in Part I, shade the correct ovals on the Optical Answer Sheet (OAS) provided using a 2B pencil.
5. For questions 31 to 44, give your answers in the spaces given in the Part II.

| | Maximum | Marks Obtained |
|------------------|------------------|-----------------------|
| Booklet A | 60 marks | |
| Booklet B | 40 marks | |
| Total | 100 marks | |

* This booklet consists of 19 pages. (Pg. 1 to 19)

This paper is not to be reproduced in part or whole without the permission of the Principal.

6049

PART I (60 Marks)

For each question from 1 to 30, four options are given. One of them is the correct answer. Make your choice (1, 2, 3 or 4). Shade the correct oval (1, 2, 3 or 4) on the Optical Answer Sheet.

1. Study the classification charts below. Which one of the following classifications is correct?

(1)

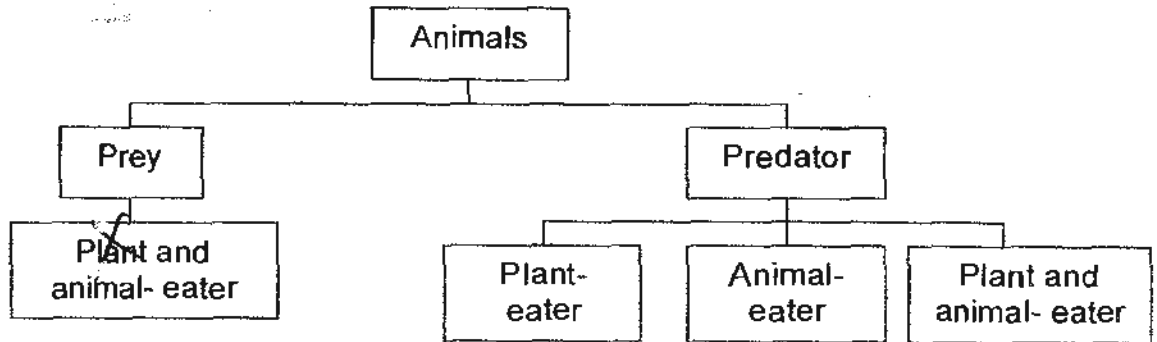

(2)

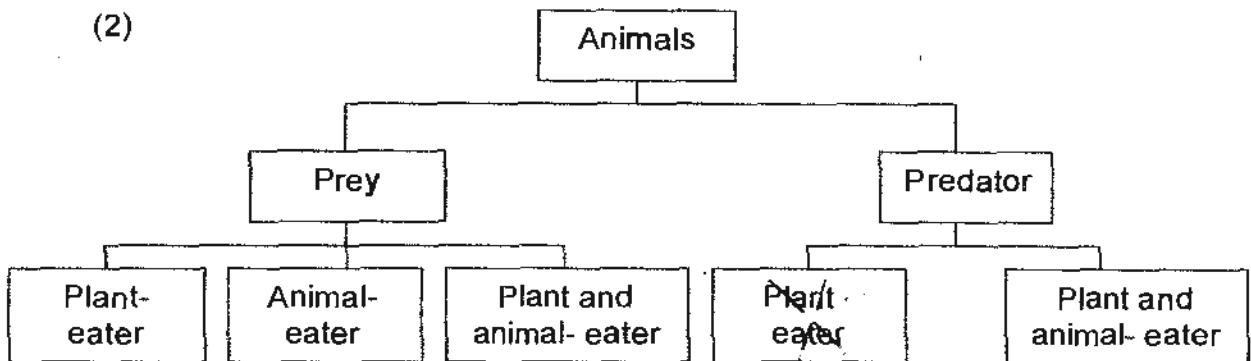

(3)

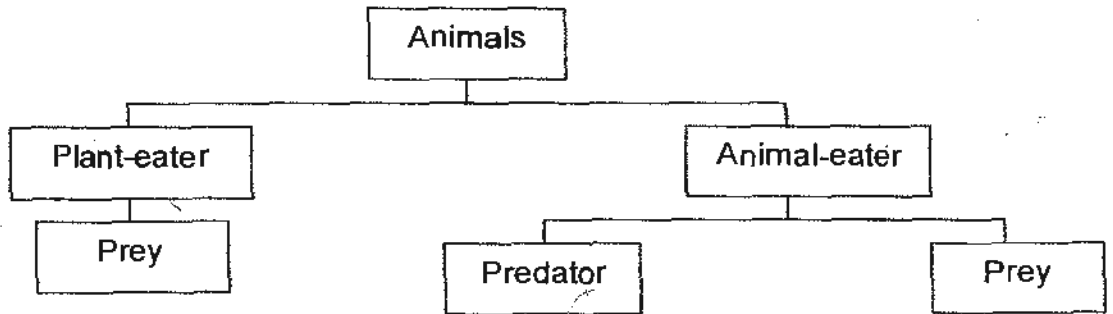

(4)

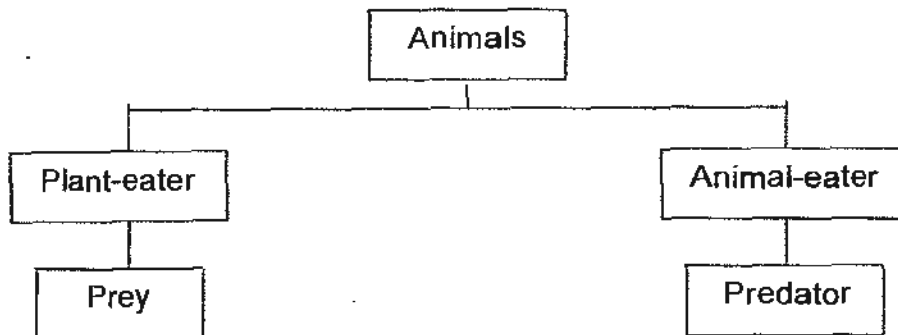

2. A beaker containing a piece of uncooked meat was left in a room for a week. After a week, maggots which are the young of housefly were observed on the meat as shown below.

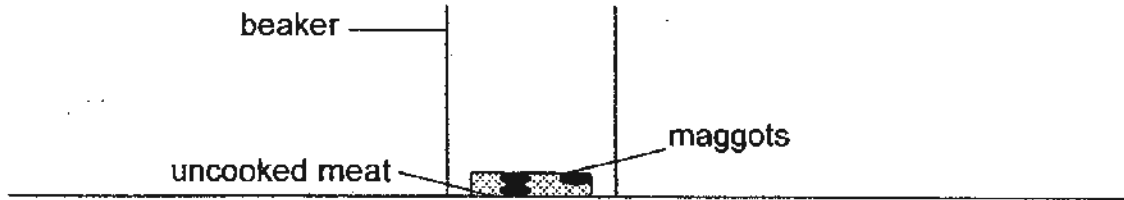

Erina wanted to prove that the maggots did not come from the meat. She set up the 4 beakers such as below.

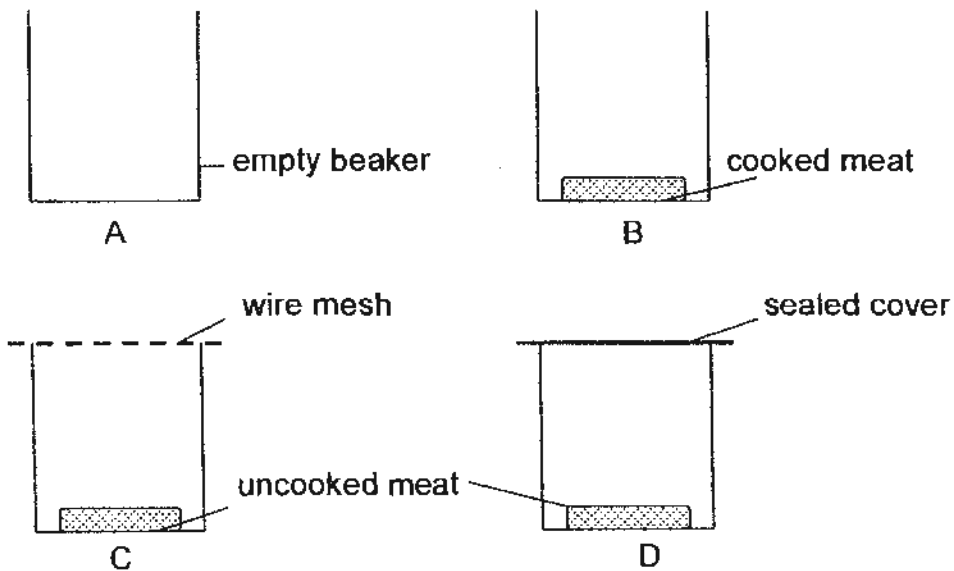

Which set-ups should she use to show that the maggots did not come from the meat?

- (1) A and B
 (2) A and C
 (3) B and C
 (4) C and D

3. The flow chart below shows the characteristics of different animals J, K and L.

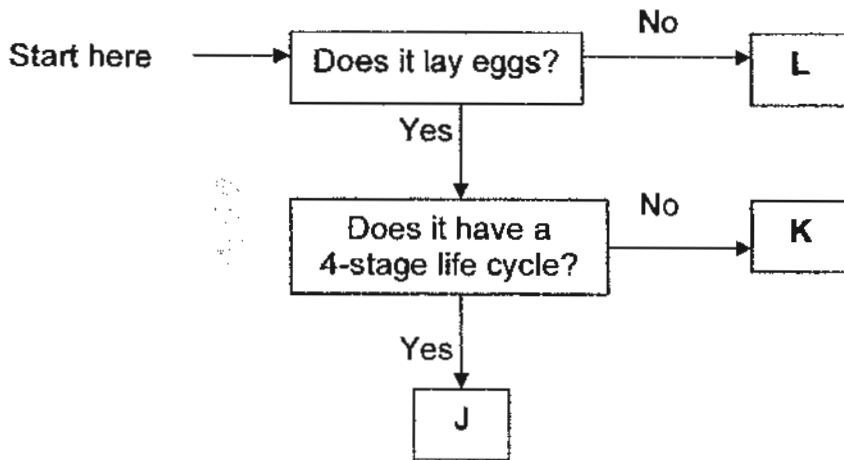

Based on the flow chart, which of the following statement(s) is/are correct?

- A: K lays eggs.
- B: L has a 3-stage life cycle.
- C: J gives birth to young alive.

- (1) A only
- (2) C only
- (3) A and B only
- (4) A, B and C

4. A group of students observed that there was an increase in the number of bees visiting the plants in a garden at a certain period of the year. They also observed the life cycle of the plant as shown below.

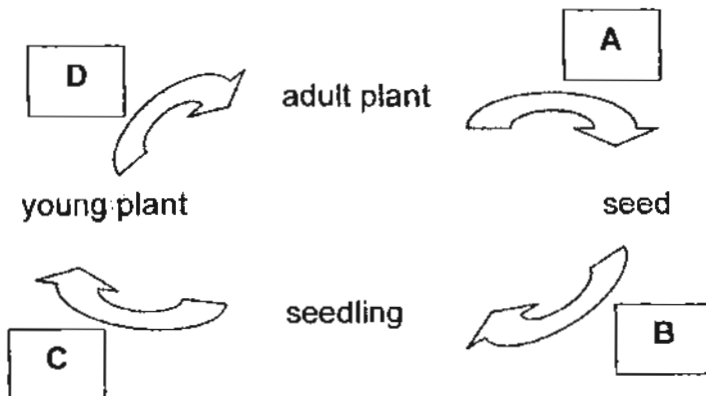

Which part of the life cycle do you think there is an increase of bees visiting the plants?

- (1) A
- (2) B
- (3) C
- (4) D

5. Refer to the pictures shown below.



mother cat



kitten

Which part of the cell below has enabled the kitten to look like the mother?

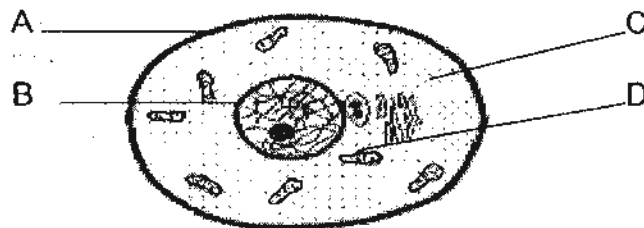

- (1) A
- (3) C

- (2) B
- (4) D

6. Study the digestive system diagram below.

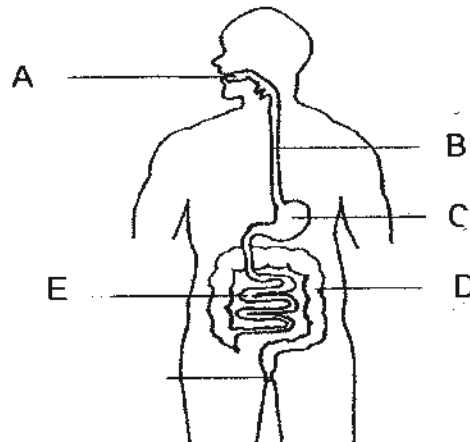

In which parts of the digestive system does digestion not take place?

- (1) A and B only
- (3) A, B and D only

- (2) B and D only
- (4) C, D and E only

7. The graphs below shows the amount of oxygen Jonathan uses when he is engaged in different activities such as walking, running and resting.

Which one of the graphs shown below correctly shows the amount of oxygen Jonathan uses when he walks, runs and then rests?

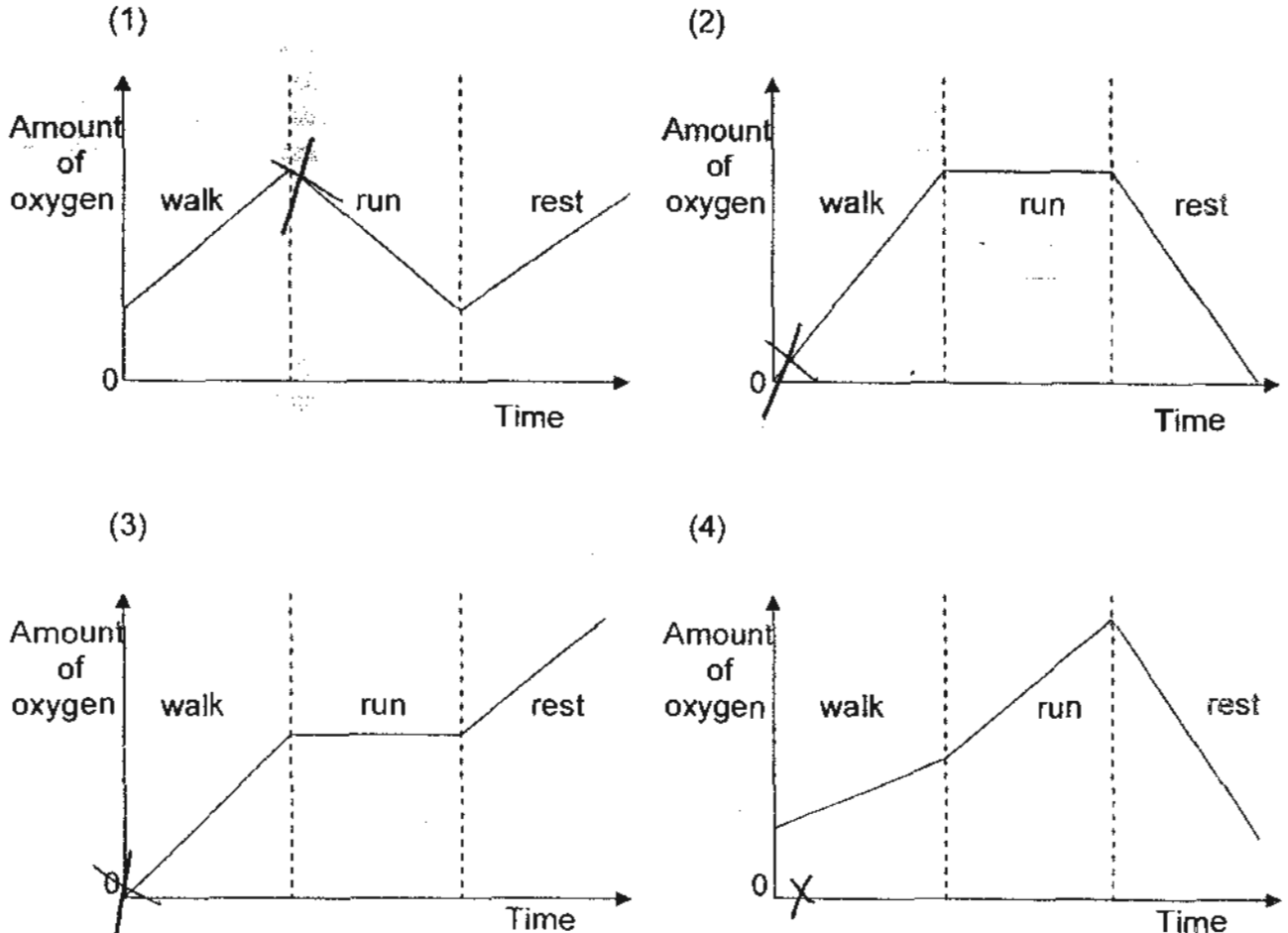

8. Seaweeds are plants that live in the sea and on the seashore. An example of seaweed is shown below.

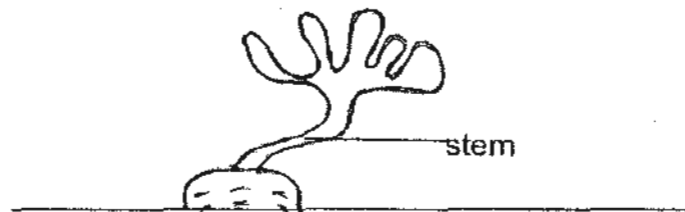

Waves pull the seaweed in different directions and the seaweed is adapted to survive in the sea's waves.

Which property of the stem has helped it to adapt in its environment?

- (1) Strength
- (2) Hardness
- (3) Elasticity
- (4) Flexibility

9. A forest has just been destroyed by wildfire on a hot blazing day after a dry spell in the month of July.

Which of the following statements indicate the possible effects this would have on the environment?

- A: The soil will become less fertile.
- B: Soil erosion will soon take place when the wet season comes.
- C: This may lead to global warming that would cause sea level to rise.
- D: Plants in the surrounding areas will be eaten up by all the surviving animals.

- (1) A and D only
- (2) B and C only
- (3) A, B and C only
- (4) B, C and D only

10. Stuart wanted to find out which type of soil contains the most amount of air. He placed one cupful of each type of soil, A, B and C into each of the three jars shown below.

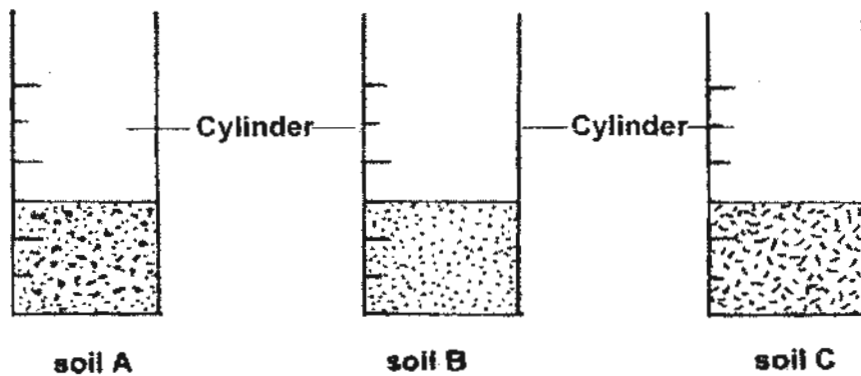

He then poured a cupful of water into each of the three jars at the same time. The diagrams below show Stuart's observations of the 3 set-ups after the cupful of water was poured into each jar of soil at the end of the experiment.

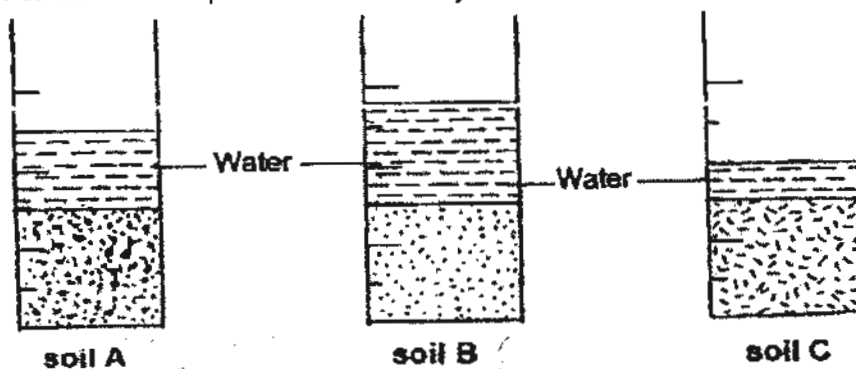

Which one of the following shows the correct arrangement of the soils, starting from the soil with the least amount of air to the soil with the most amount of air?

- (1) A, B, C
- (2) B, A, C
- (3) C, B, A
- (4) C, A, B

11. Meng Li placed a plant in the dark to de-starch it for 48 hours and then partially covered one of the leaves with black paper. After doing so, he placed the plant under the sun for another 5 hours as shown below.

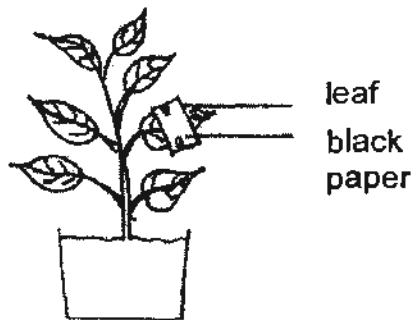

At the end of the experiment, he plucked off the leaf with black paper and removed the black paper and observed the leaf as shown.

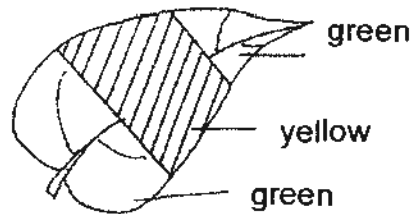

He tested the leaf for starch by using iodine solution and observed the leaf as shown below.

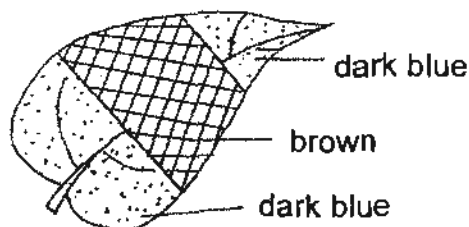

Which of the following can be deduced from the above experiment?

- A: Air is needed for photosynthesis.
- B: Sunlight is needed for photosynthesis.
- C: Chlorophyll is needed for photosynthesis





(1) A only

(2) B only

(3) B and C only

(4) A, B and C

12. Birds have different types of beaks to help them survive in the environment. Study the table below carefully.

| | |
|---|---|
| P |  |
| Q |  |
| R |  |
| S |  |

Which of the above is/ are (a) carnivore(s)?

- (1) P only
 (2) Q and R only
 (3) P and S only
 (4) Q, R and S only
13. The following food relationship was observed among four living things W, X, Y and Z.

X is eaten by W
 W feeds on Y
 Z does not feed on X but Y
 Y gets its food from X

Which one of the following is the correct classification of the living things?

| | Food producer | Plant -eater | Animal and Plant eater | Animal Eater |
|-----|---------------|--------------|------------------------|--------------|
| (1) | Z | Y | W | X |
| (2) | X | Y | W | Z |
| (3) | X | Z | Y | W |
| (4) | Y | X | Z | W |

14. Heavy haze is recently observed in a city and the trees there are found to be dying.

Which of the following is / are the reasons why the trees are dying?

- A: Photosynthesis will be affected as sunlight is being blocked by the haze.
 B: The stomata are being blocked by the haze as gaseous exchange cannot take place.
 C: The trees will not be able to have enough nutrients as a result of haze

- (1) A only
 (2) A and B only
 (3) B and C only
 (4) A, B and C

15. The diagram below shows part of a river that flows downstream.

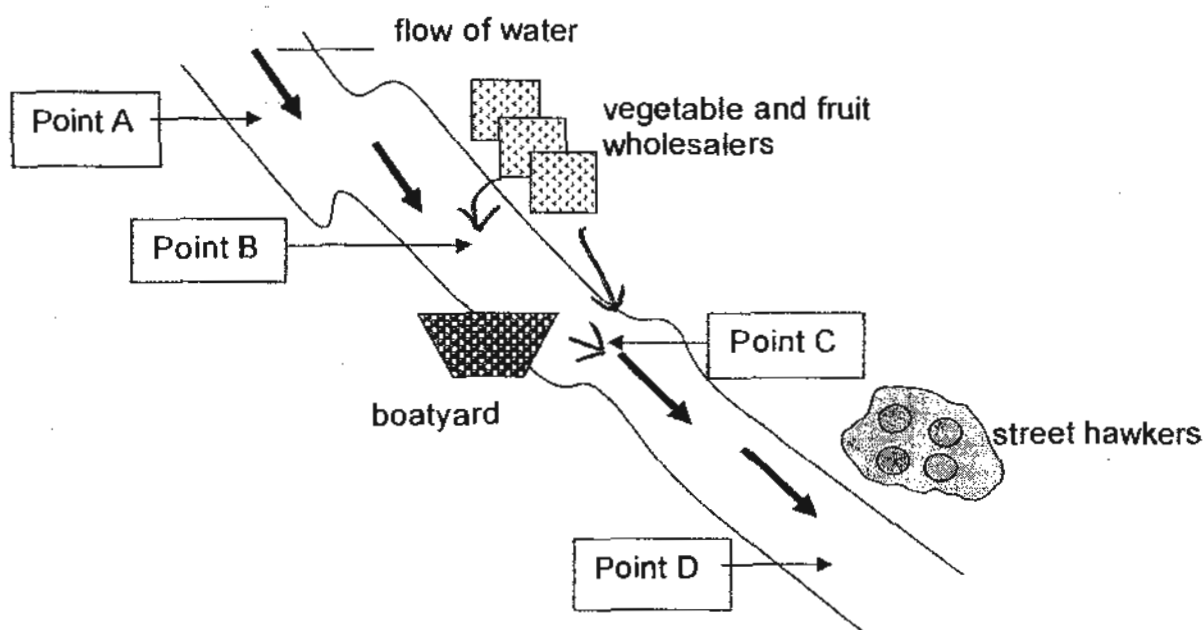

Based on the above diagram, which of the following statements are true about the environment?

- A: The river at Point A is the least polluted of all.
 B: The river at Point B is cleaner than that at Point C.
 C: The source of pollution at Point C comes from the activities of the boatyard ~~only~~.
 D: The street hawkers contribute most to the pollution in the whole river as Point D is most polluted.

- (1) A and B only
 (2) C and D only
 (3) A, B and D only
 (4) A, B, C and D

16. Vincent made parachutes as shown below.

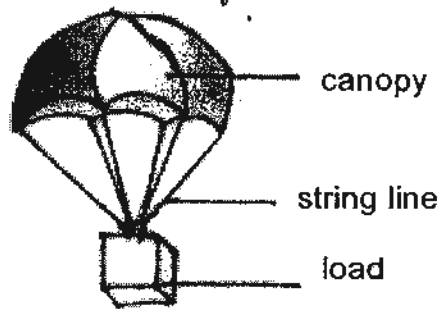

He changed some of the factors of the parachutes to carry out an investigation. He dropped each parachute from the same height. He measured how long it took for each parachute to reach the ground.

The results were then recorded in the table below.

| Set-up | Materials used for canopy | Length of string lines (cm) | Area of materials used for canopy (cm ²) | Time taken to fall 10m (s) |
|--------|---------------------------|-----------------------------|--|----------------------------|
| I | Plastic | 20 | 300 | 2.5 |
| II | Plastic | 20 | 100 | 1.0 |
| III | Plastic | 30 | 300 | 3.5 |
| IV | Paper | 20 | 100 | 1.0 |
| V | Paper | 20 | 300 | 2.5 |
| VI | Paper | 30 | 100 | 2.0 |

Based on the results above, which factors will definitely help Vincent to make a toy with a wing-like structure that will stay afloat in the air for a longer period of time?

- A: Mass of the toy
- B: Length of the wing-like structure
- C: Material of the wing-like structure
- D: Surface area of the wing-like structure

- (1) A and C only
- (3) B and D only

- (2) B and C only
- (4) B, C and D only

17. The diagram below shows a piece of styrofoam floating in a basin of water.

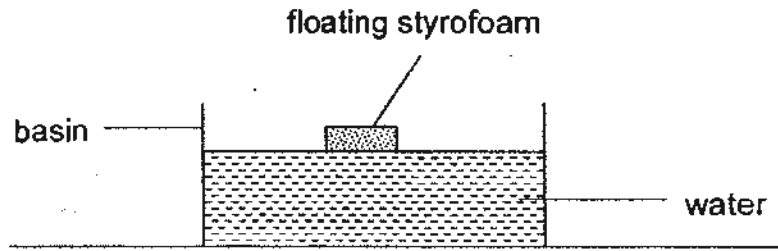

Plastic cups are inverted over the styrofoam and held down.

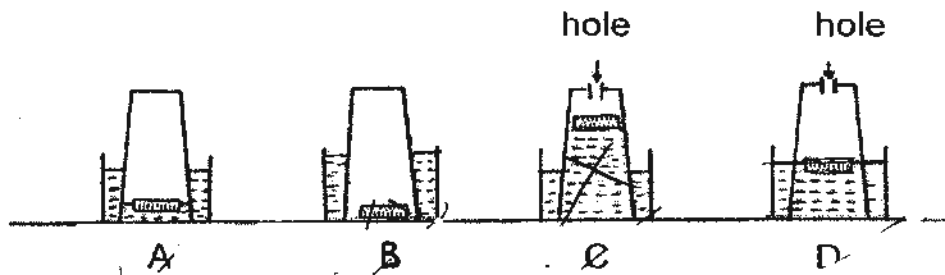

Which of the above diagrams show what could possibly happen to the styrofoam and water?

- (1) A and C only
 (2) B and C only
 (3) A and D only
 (4) C and D only
18. Three flasks taken from a room were placed in different basins of water. Each flask was fitted with a stopper and a narrow glass tube. There was a drop of ink inside the glass tube. The drop of ink for each flask was observed as shown below.

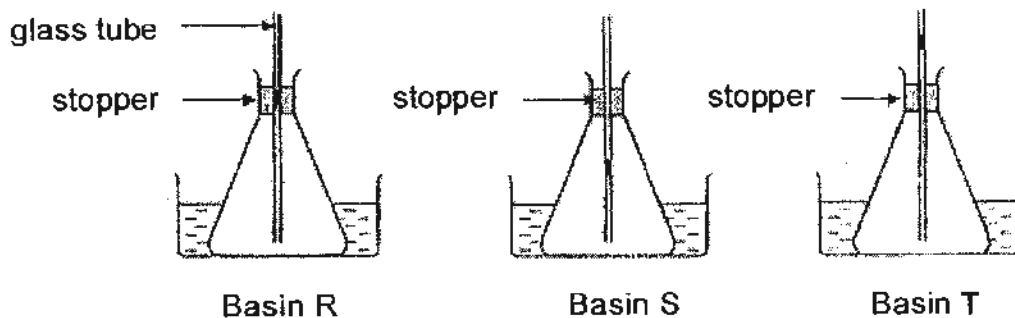

What is the likely temperature of the water in each basin?

| | Basin R | Basin S | Basin T |
|-----|---------|---------|---------|
| (1) | 20°C | 40°C | 50°C |
| (2) | 50°C | 30°C | 20°C |
| (3) | 40°C | 20°C | 60°C |
| (4) | 60°C | 30°C | 40°C |

19. The table below shows the states of four substances W, X, Y and Z at different temperatures.

| Substance | State of substance at | | |
|-----------|-----------------------|--------|--------|
| | 0°C | 30°C | 100°C |
| W | solid | solid | solid |
| X | solid | liquid | liquid |
| Y | solid | solid | liquid |
| Z | gas | gas | gas |

Which of the following statements are correct?

A: The boiling point of Substance Y is 100°C.

B: Substance Z has the lowest boiling point.

C: The freezing point of substance X is 0° C.

D: Substance W has the highest freezing point.

(1) A and C only

(2) B and C only

(3) B and D only

(4) A, B and D only

20. Four identical containers E, F, G and H were filled with the same volume of water. They were left in four places with different conditions for 5 hours as shown in the table below.

| Container | E | F | G | H |
|------------|------------------|---------------------|----------------------|-----------------|
| Conditions | Cloudy and windy | Sunny but not windy | Cloudy but not windy | Sunny and windy |

Which one of the following graphs is likely to show the volume of water in containers E, F, G and H after 5 hours?

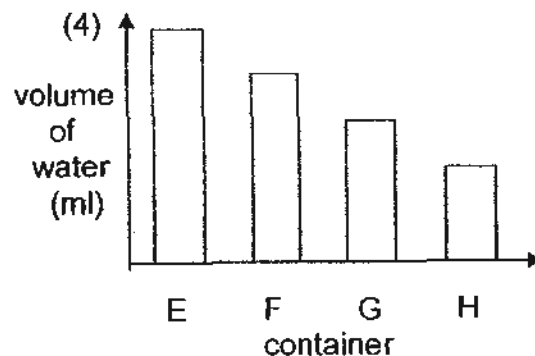
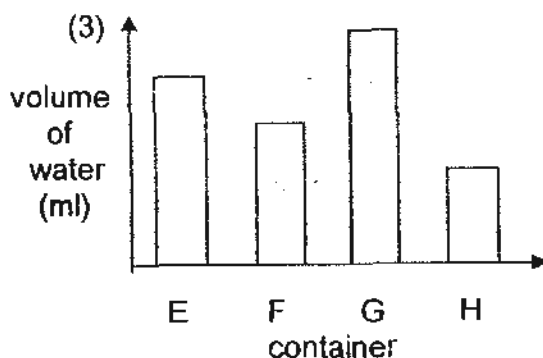
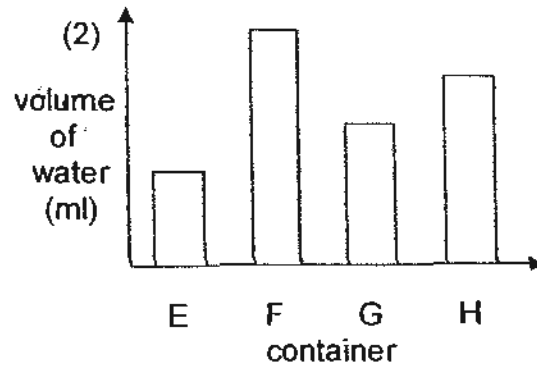
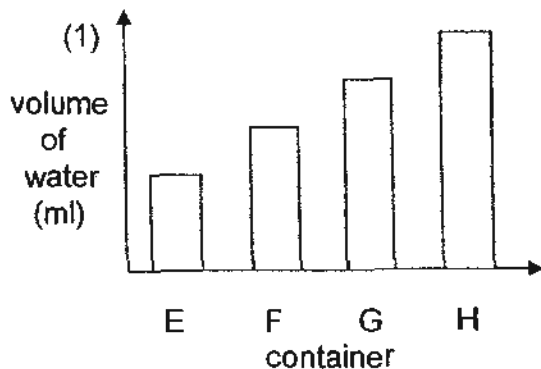

21. Four thumbtacks (P, Q, R and S) are attached to different parts of a copper rod with wax. When a candle flame is used to heat the spot at Y, the four thumbtacks dropped in the following order S, P, R, Q.

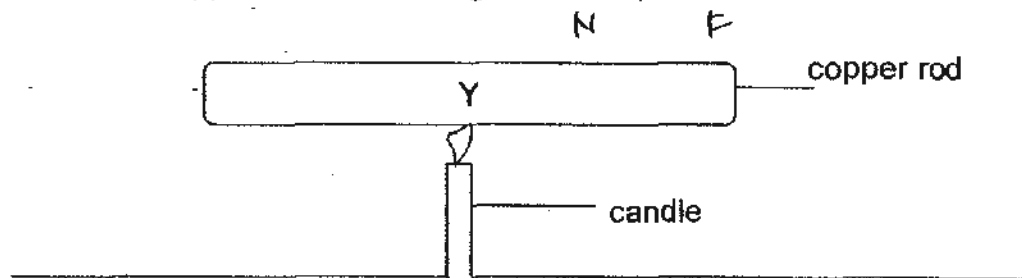

Which one of the following shows the correct distance of each thumbtack from Y?

| | P | Q | R | S |
|-----|------|------|------|------|
| (1) | 6 cm | 4 cm | 2 cm | 9 cm |
| (2) | 4 cm | 9 cm | 6 cm | 2 cm |
| (3) | 6 cm | 9 cm | 4 cm | 2 cm |
| (4) | 6 cm | 2 cm | 4 cm | 9 cm |

22. A block of ice is put in a sealed plastic box as shown in the diagram below. The box is then placed in the middle of a classroom on a hot day.

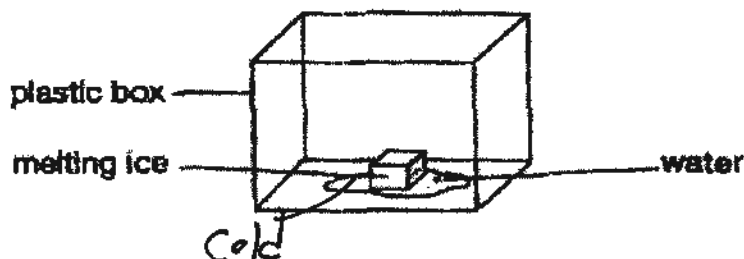

What will happen to the temperature of the melting ice, the water and the air in the box after some time?

| | Temperature of | | |
|-----|------------------|------------------|----------------|
| | melting ice | water | air in the box |
| (1) | remains the same | increases | decreases |
| (2) | decreases | remains the same | increases |
| (3) | remains the same | decreases | decreases |
| (4) | increases | remains the same | increases |

23. Study the following set-up carefully.

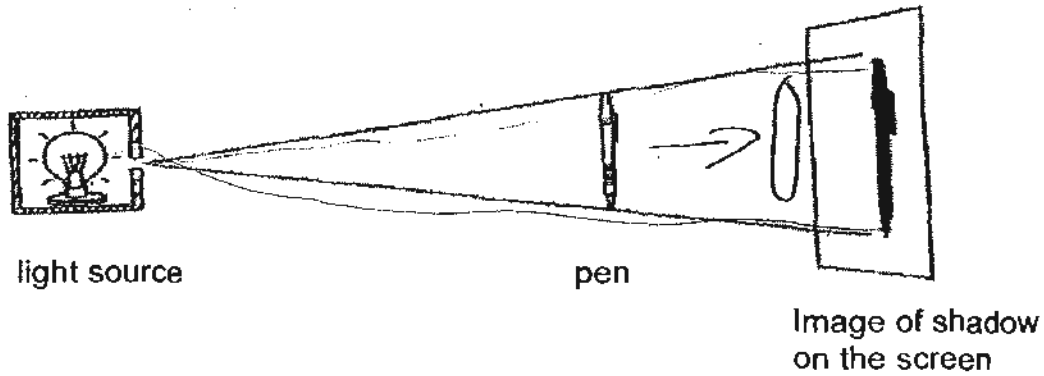

Which of the following shows the correct relationship between the distance of the light source from the pen and the length of the shadow?

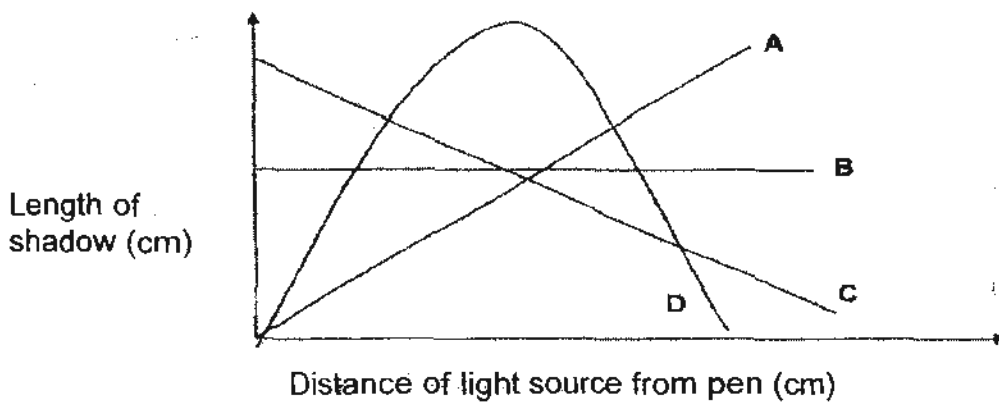

- (1) A (2) B
(3) C (4) D

24. A fan and a container of water were connected to some batteries as shown below.

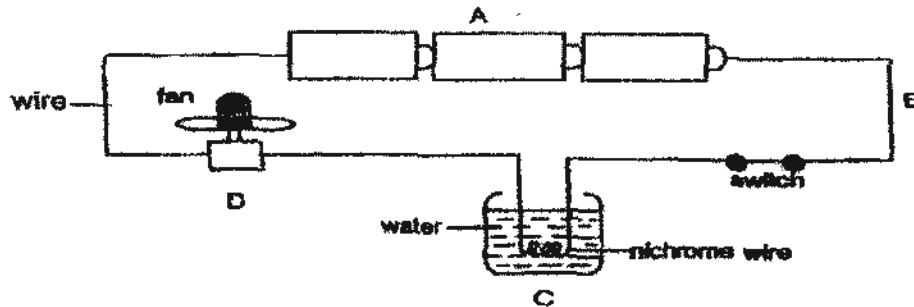

When the switch was closed, the fan started moving and the water in the container was slowly heated up.

What were the main energy changes that have taken place at each point labelled A to D?

| | A | B | C | D |
|-----|-------------------|-------------------|--------------|----------------|
| (1) | Potential energy | Electrical energy | Light energy | Heat energy |
| (2) | Electrical energy | Potential energy | Light energy | Kinetic energy |
| (3) | Potential energy | Electrical energy | Heat energy | Kinetic energy |
| (4) | Electrical energy | Potential energy | Heat energy | Sound energy |

25. June was told to investigate if the arrangement of the bulbs in a circuit affects their brightness. She set up four circuits as shown in the diagrams below.

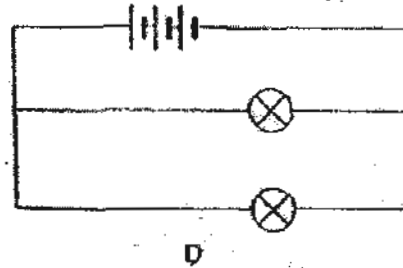
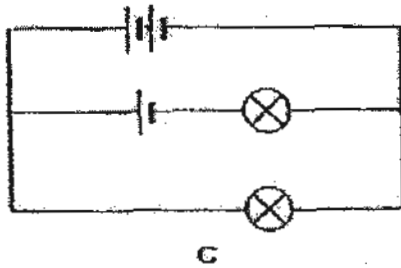
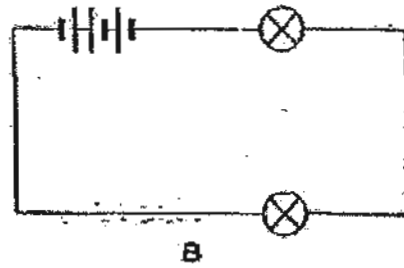
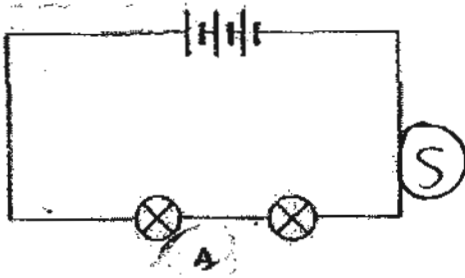

Which of the two circuits shown above should be used to ensure a fair test?

1. A and C
2. A and D
3. B and C
4. B and D

27. The table shows the properties of four screens.

| Screen | Allows light to pass through | Does not allow light to pass through |
|--------|------------------------------|--------------------------------------|
| A | ✓ | |
| B | | ✓ |
| C | ✓ | |
| D | | ✓ |

Danny cut a square piece of black paper. He cut a slit in the middle and used the piece of paper to cover a flashlight. A beam of light could be seen when he shone it on a screen as shown below.

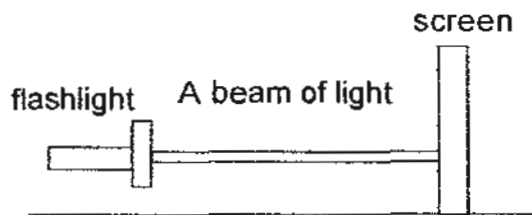

Which one of the following arrangement of the screens allow light to be shown on Screen D?

| | |
|-----------------|-----------------|
| <p>P</p> | <p>Q</p> |
| <p>R</p> | <p>S</p> |

- (1) Q and R only
- (3) P, Q and R only

- (2) P and R only
- (4) Q, R and S only

28. The table below shows how objects A, B, C and D react with each other.

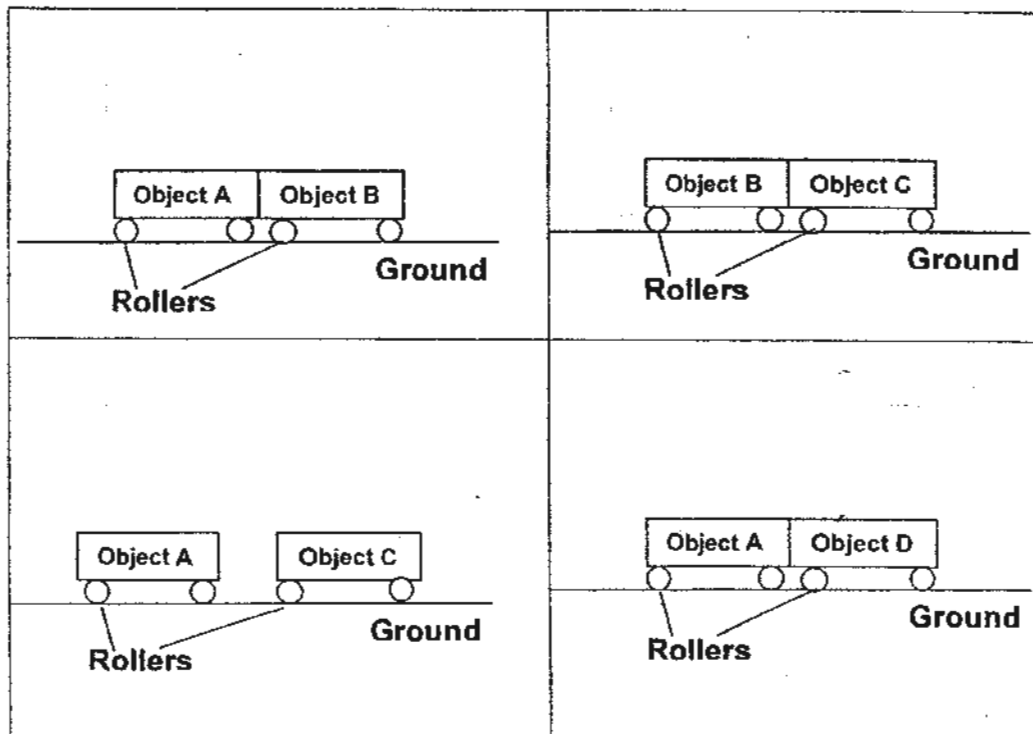

Which of the following about objects A to D is definitely correct?

| | Magnet(s) | Not magnet(s) | Not possible to tell if object(s) is / are magnet(s) |
|-----|----------------|---------------|--|
| (1) | A and B | C | D |
| (2) | B and D | A | - |
| (3) | <u>A and C</u> | - | <u>B and D</u> |
| (4) | A, B and D | - | C |

29. Min Han wanted to compare the texture of 4 different types of surfaces W, X, Y and Z. He set up an experiment as shown below.

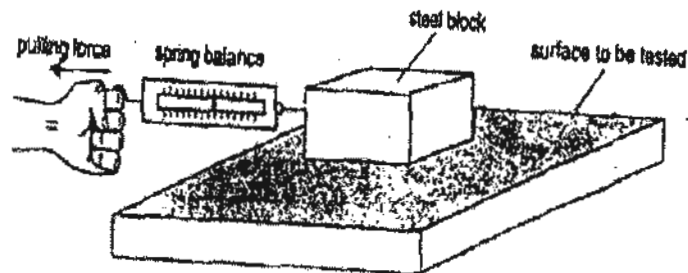

He measured the forces needed to pull the steel block on the four surfaces using the spring balance and recorded the results as shown in the table below.

| Surface | Force (N) |
|---------|-----------|
| W | 12.1 |
| X | 4.5 |
| Y | 6.8 |
| Z | 1.3 |

Which of the following shows the correct order of the surfaces W, X, Y and Z when arranged from the smoothest to the roughest?

- (1) W, X, Y, Z
 (2) X, Y, W, Z
 (3) Z, X, Y, W
 (4) Z, X, Y, W
30. Yew Beng took two identical sheets of paper and let them fall several times to the ground in an enclosed room as shown in picture A. He found out that the time taken for the papers to reach the ground was about the same. He then squashed one of the sheets of paper into a tight ball and repeated the experiment as shown in picture B. This time, he found out that the squashed ball of paper fell to the ground more quickly than the sheet of paper.

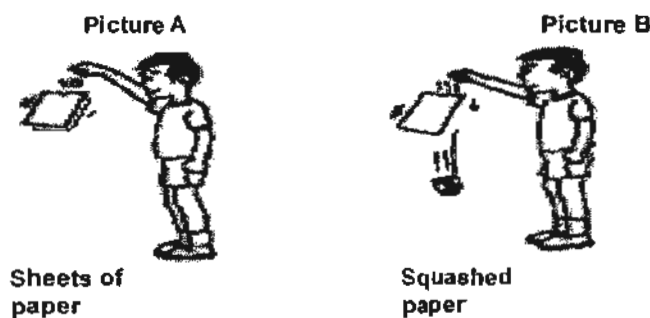

Which of the following is the likely reason to explain the difference in the time taken between the sheet of paper and the squashed paper to reach the ground?

- (1) The sheet of paper weighed more when it was squashed into a ball.
 (2) There is a greater force pushing against the sheet of paper upwards.
 (3) Gravity acts more on the squashed paper than on the sheet of paper.
 (4) Magnetic force of the Earth has acted on the squashed paper more than the sheet of paper.

End of Booklet A

Part II (40 marks)

For questions 31 to 44, write your answers in this booklet.

31. Susan planted some chilli seeds in 2 pots of similar size. She put ^{5 Seeds} 5 seeds in pot M and 1 seed in pot N. She watered the pots of seeds daily. She then plotted the average height of the seedlings for each pot in the graph below.

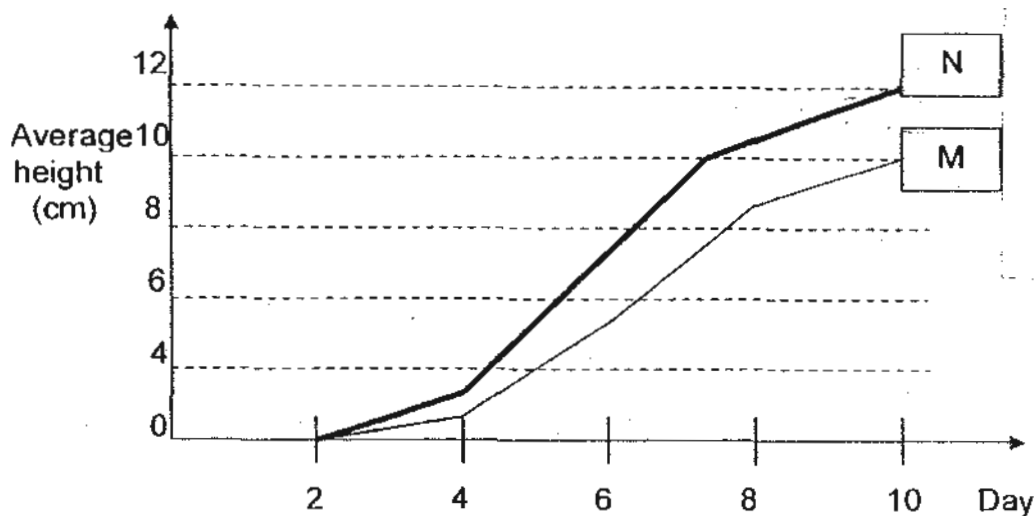

- (a) She observed that the plants in pot N were growing taller with thinner stems. Explain the observation. [1m]

- (b) After 10 days, the plants in pot M were observed to grow taller than the plants in pot N. Explain why? [1m]

- (c) How do plants prevent the situation from happening in pot N? [1m]



Rosyth School
Preliminary Examination for 2010
STANDARD SCIENCE
Primary 6

Name: _____

Total
Marks: _____

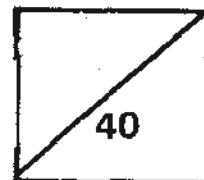

Class: Pr _____

Register No. _____

Duration: 1 h 45 min

Date: 26th August 2010

Parent's Signature: _____

Booklet B

Instructions to Pupils:

1. For questions 31 to 44, give your answers in the spaces given in this Booklet B.

* This booklet consists of 15 pages.

This paper is not to be reproduced in part or whole without the permission of the Principal.

32. Study the food chain shown below.

Wheat plant → grasshopper → sparrow → python

(a) A lot of chemical was sprayed on the wheat plants to get rid of weeds at a farm. In the long run, the chemical was found to be greatest in the python. Explain how this has happened. [1m]

(b) What would be the immediate effect on the populations of the plants, the grasshoppers and the pythons if all the sparrows are dead by a sudden cause of disease? Draw 3 lines in the graph below and label them correctly to show the change in the populations of the plants, the grasshoppers and the pythons. [2m]

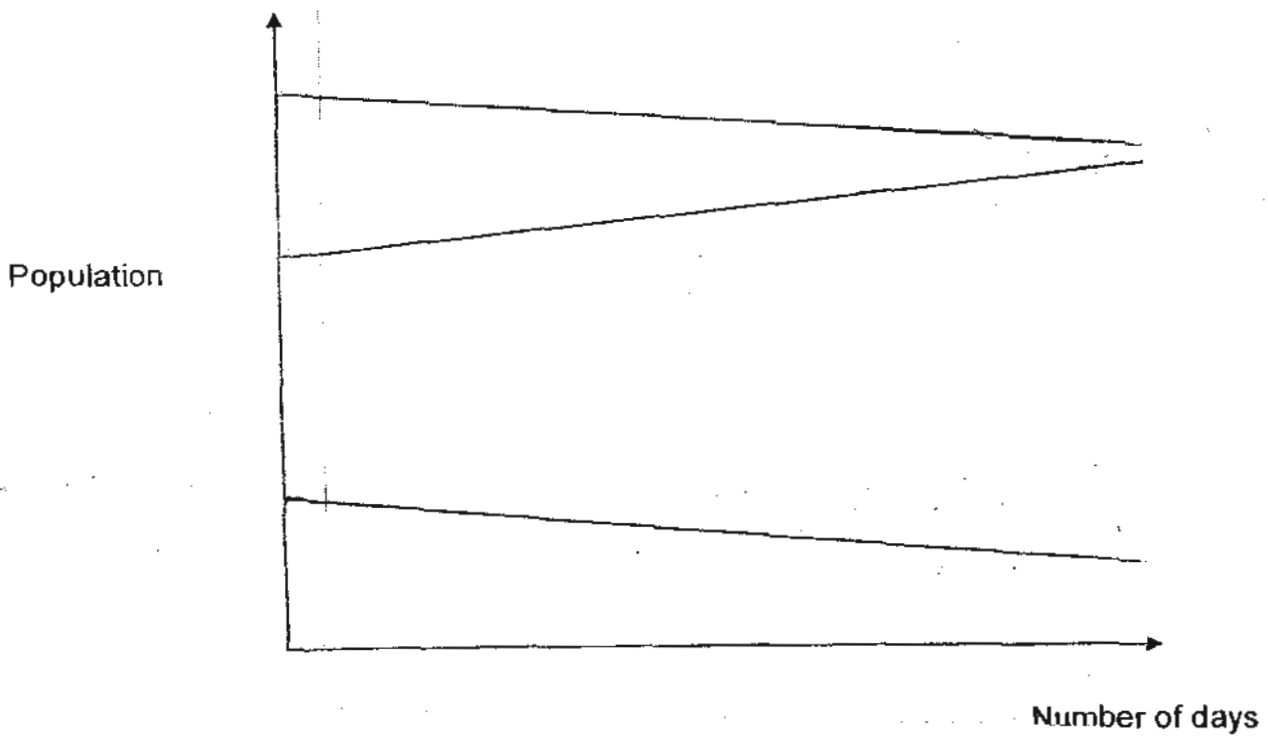

33. Jill put three different types of animals X, Y and Z into containers P, Q and R as recorded in the table below. Only one of the animals is a plant-eater. Jill also placed water plants as food in each of the three containers.

| Container | Type of animals |
|-----------|-----------------|
| P | X and Y |
| Q | Y and Z |
| R | X and Z |

She counted the number of animals at the end of each week for two weeks. She did not see any dead animals in the container and she recorded her results in the graphs below.

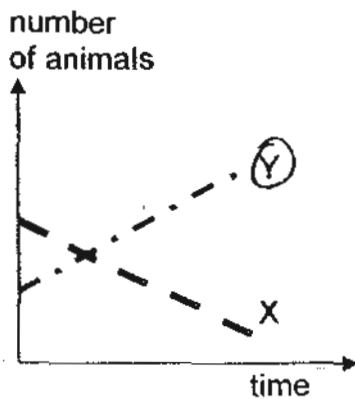

container P

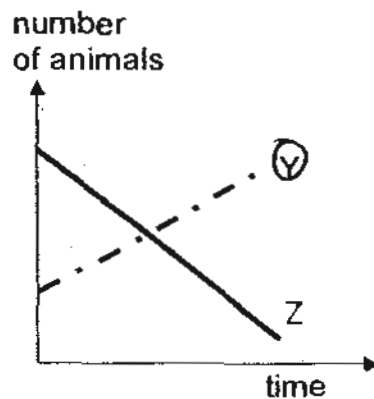

container Q

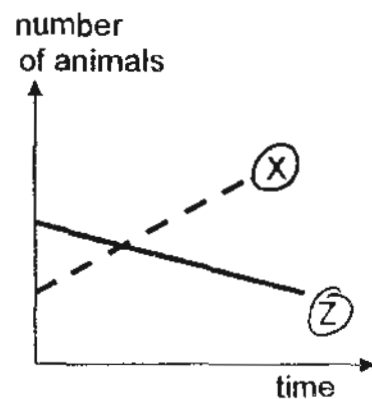

container R

- (a) In the experiment above, what is the significance of providing food for the plant-eater? [1m]

Jill put the same number of animals X, Y, Z and water plants in another container. She left the container for a month.

- (b) Which animal would have the least population size? Explain how it happened.

34. Edward collected some samples of water and water plants from three different rivers P, Q and R. He wanted to find out how the different ~~samples~~ *affected the rate of photosynthesis of the plants* collected at the sites. The diagram below shows the set-up of the water and water plant collected from River P. The experiment was repeated with water and water plant collected from River Q and R respectively.

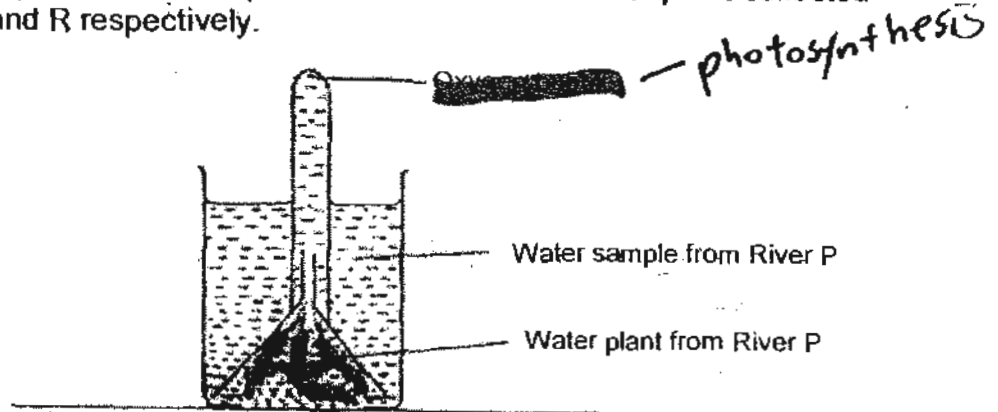

He measured the volume of oxygen collected in the test tube in each set-up at the end of the experiment. He tabulated his results as follows.

| Water sample from | Volume of oxygen collected (cm ³) |
|-------------------|---|
| P | 0.1 |
| Q | 1.6 |
| R | 0.8 |

- (a) Based on his observations above, what was ~~his~~ *his conclusion to* the experiment?

- (b) Which of the above samples was most probably collected from a river with its surface all covered with algae or has experienced algae bloom? Give a reason for your answer. [1m]

35. Study the water cycle below.

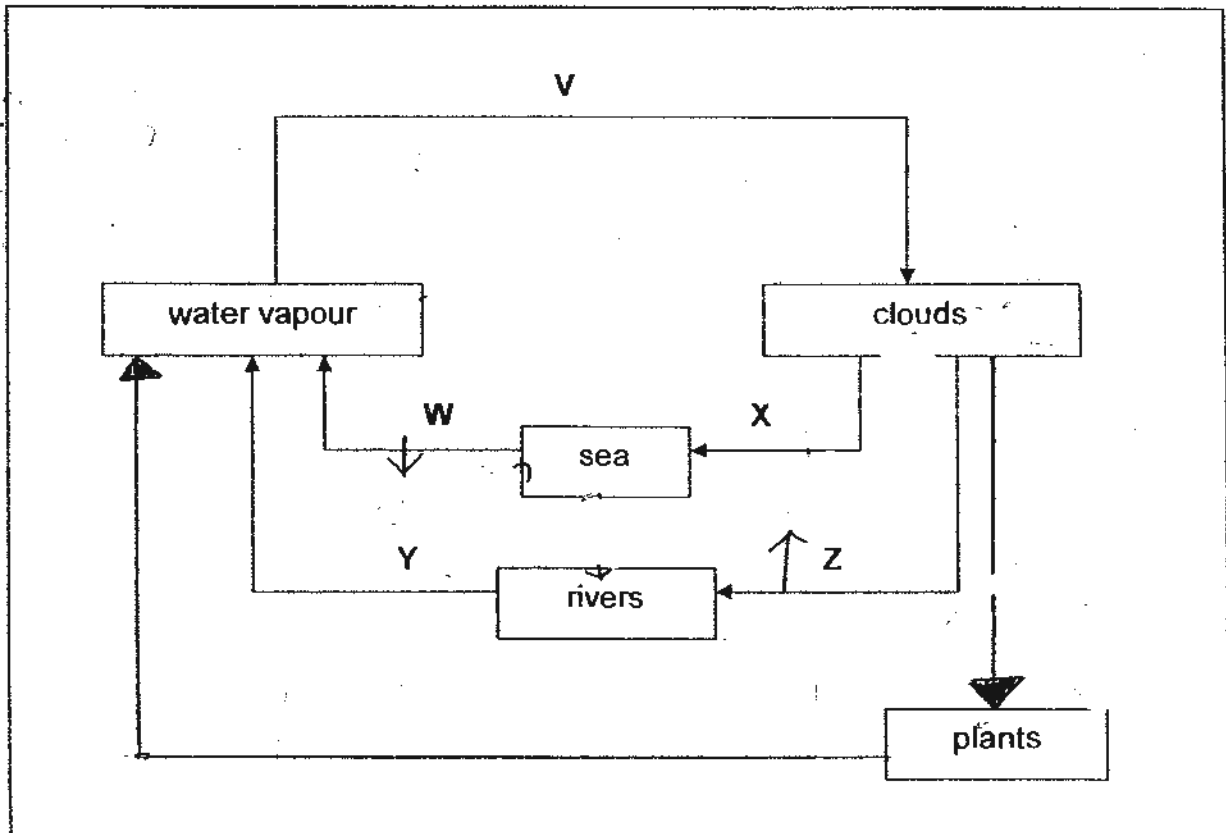

(a) In the diagram above, draw two arrows to show how plants can be part of this water cycle. [1m]

(b) Fill in the blanks below with the letters V, W, X, Y, or Z to show the following: [1m]

(i) No change in state: _____

(ii) Change from gaseous state to liquid state: _____

(c) How does the greenhouse effect on Earth help in the water cycle process? [1m]

36

- (a) State two differences between the air that is taken in and the air that is given out by the human respiratory system? [1m]

Two mirrors were left in a room for some time. When a boy breathed on one of the mirrors, droplets of water were observed on it.

- (b) Describe how the water droplets appeared on the mirror that the boy breathed onto. [2m]

- (c) Why was there no water droplets formed on the other mirror? [1m]

37. Wei Choon set up the apparatus as shown in diagram A to find out the volume of a block.

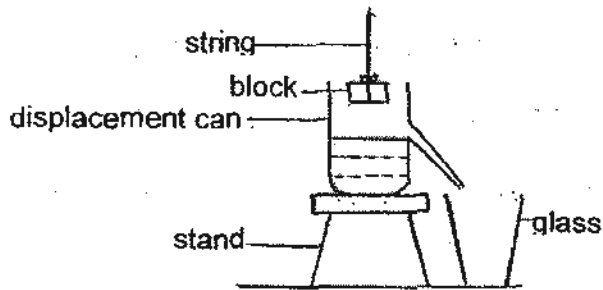

Diagram A

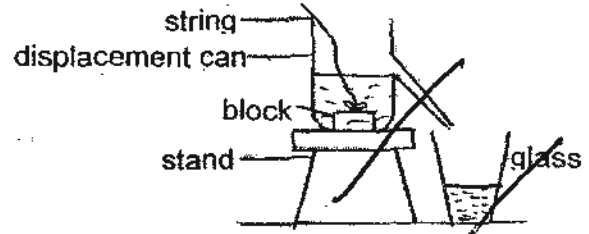

Diagram B

- (a) What would Wei Choon observe after he lowered the block into the displacement can? Draw his observations in diagram B. [2m]

- (b) What should Wei Choon do to find out the actual volume of the block? [1m]

- (c) What property of solid does the above experiment show? [1m]

38. Jennifer placed 3 sheets of different materials, A, B and C with the same thickness over the mouths of 3 containers as shown in the diagram below. She then poured 10ml of water onto each material and observed what happened to the water. Her observations are shown as follows.

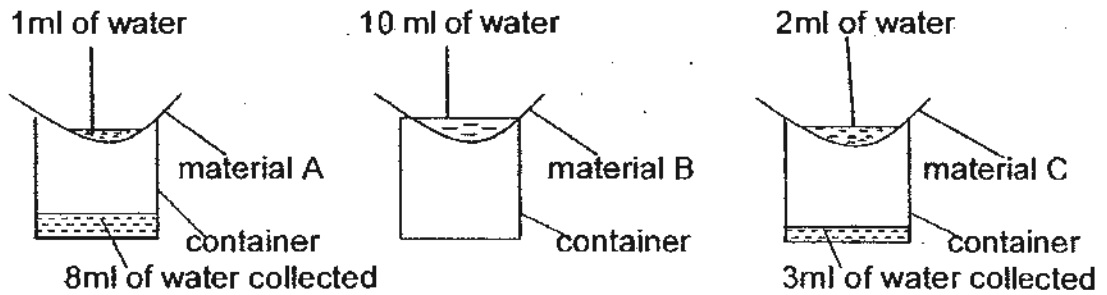

- (a) What is the aim of her experiment? [1m]

- (b) Did Jennifer carry out a fair investigation? Explain your answer. [1m]

- (c) If Jennifer wants to choose one of the 3 materials to make a towel, which materials should she choose? Support your choice. [1m]

39. The diagram below shows the common use of magnets in a door catch.

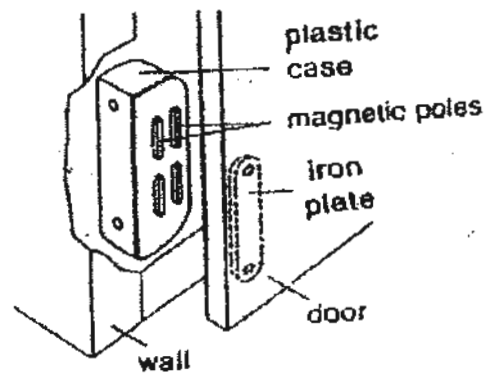

(a) Based on the diagram above, name the parts which interact with each other to enable the door catch to work. [1m]

(i) _____

(ii) _____

(b) What happens when the iron plate is changed to aluminum? Explain your answer. [1m]

40. The diagram shows a boy riding up a slope on a bicycle.

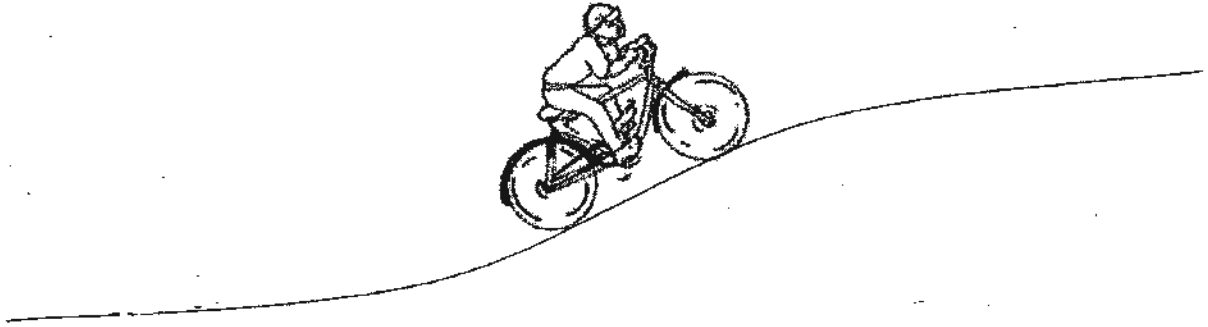

- (a) Besides air resistance that the boy would encounter, identify any other force(s) that is / are acting on the boy as he goes up the slope. [1m]

- (b) He found that he has to apply a greater force on the pedals when he moves up the slope. Explain why this is so. [1m]

41. Hassan was given Spring G and Li Ling was given Spring H. They both carried out an experiment to find out the length of each of their springs when different weights were hung on it. The graph below shows the results.

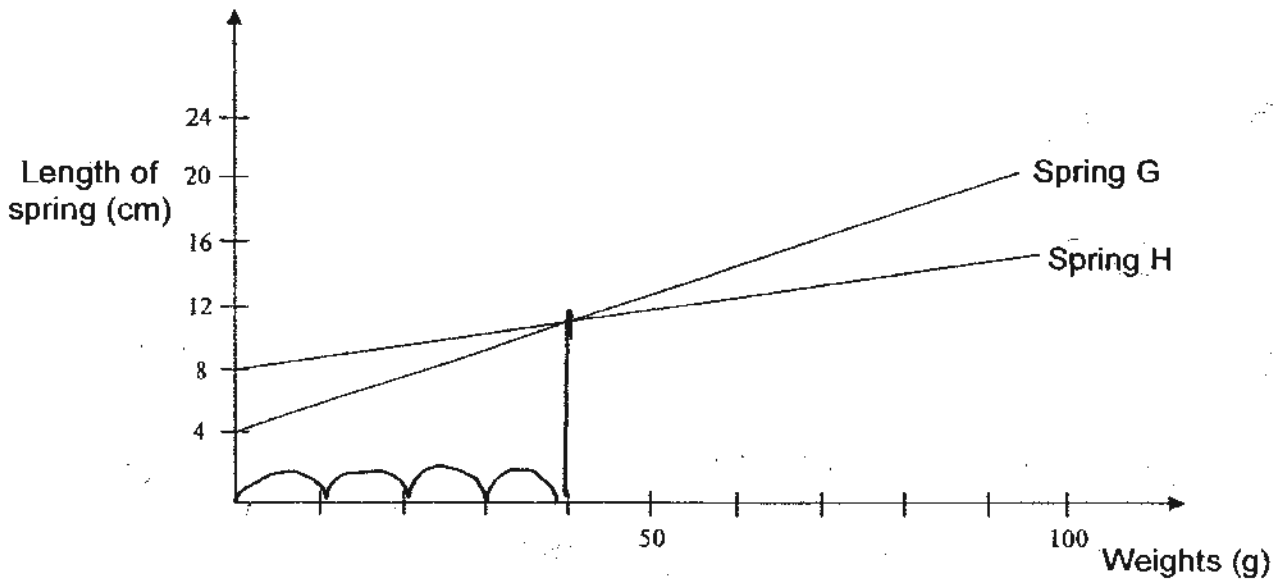

- (a) What weight was hung on each of the springs when both springs reach an identical length? [1m]

- (b) State the property of the spring that can be observed in the experiment. [1m]

42. The diagram below shows a metallic ball, X, hung using a string from a support.

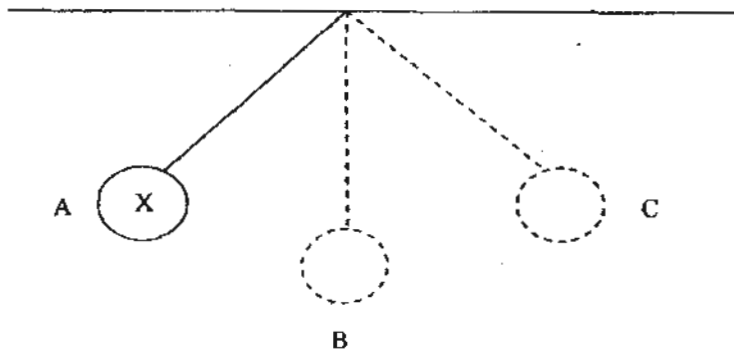

When Ball X is released at position A, it swings downwards to position B. Then it continues to move upwards to position C.

- (a) Using the axes given below, draw the graphs to show the change in the amount of gravitational potential energy of Ball X as it moves from point A to point C. [1m]

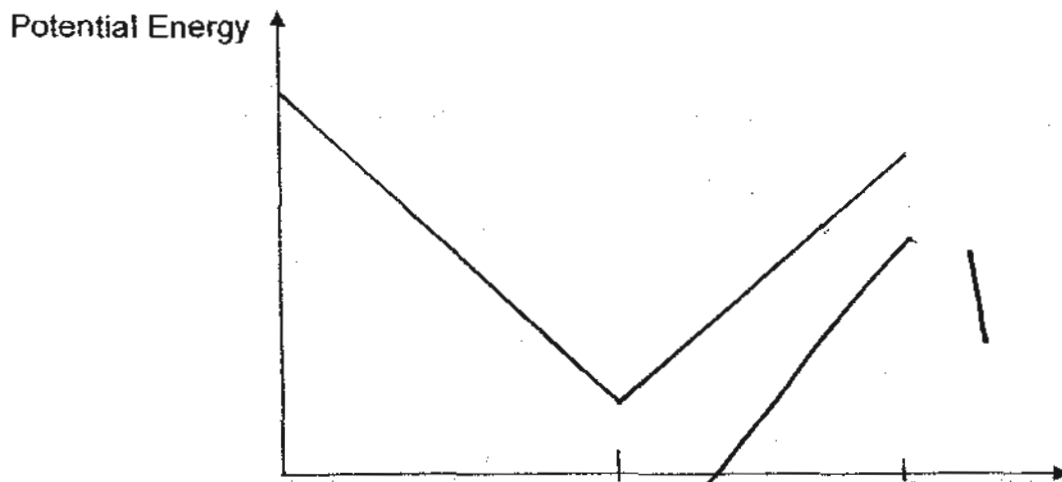

- (b) Will the ball be able to go back to the same height at A after the first round of swing? Explain. [1m]

43. The diagram below shows a circuit with 3 bulbs T, U and V.

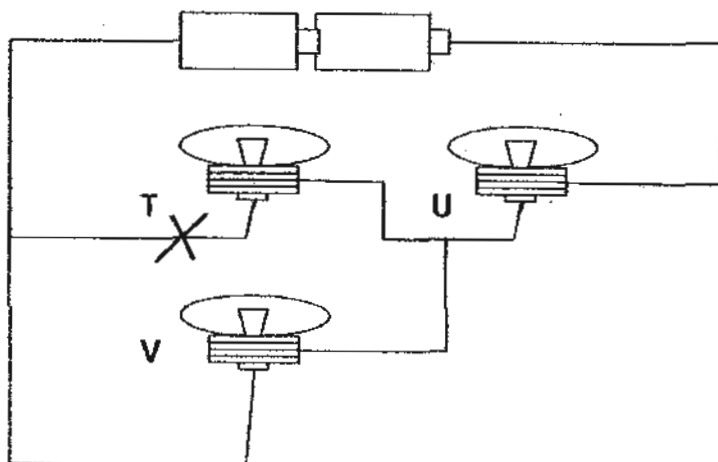

(a) A switch is placed in the circuit so that it controls only bulb T. Mark a cross (X) on the circuit above to show where the switch should be placed. [1m]

(b) What is the advantage of connecting Bulbs T and V in the manner shown in the diagram above? [1m]

(c) State what will happen if bulb U fuses. [1m]

(d) Explain a reason for your answer in (c). [1m]

44. Andrew conducted two experiments with materials W, X, Y, Z. Study the two set-ups below carefully.

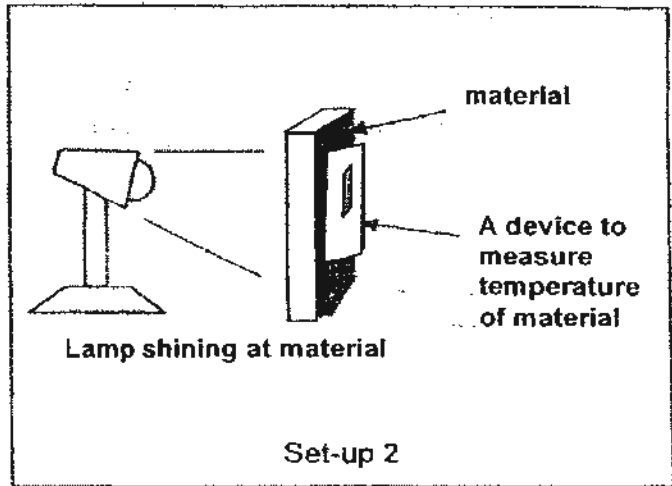
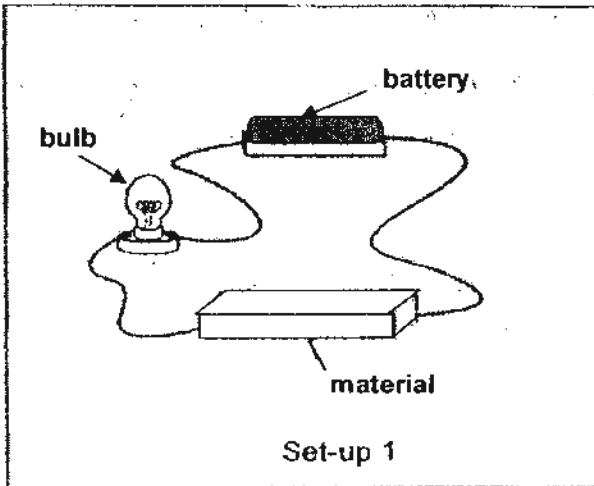

He recorded his findings in a table and a graph for set-up 1 and 2 respectively.

| Material | Brightness of the bulb |
|----------|------------------------|
| WNC | No light |
| X C | Bright |
| YPC | Dim |
| Z & C | Very bright |

Results from set-up 1

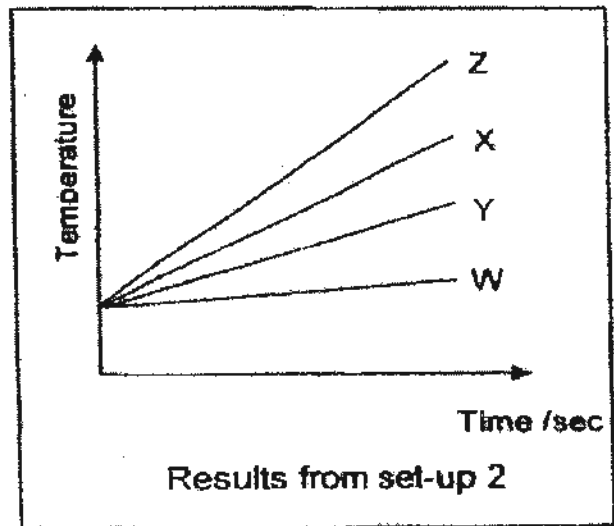

Question 44 is continued on page 15

- (a) From the results in set-up 1, which of the materials is likely made of glass?
Explain. [2m]

- (b) What conclusion can you draw about the conductivity of heat in material W, X, Y and Z? [1m]

- (c) From your answers to (a) and (b), what can you conclude about the likely relationship between the properties of electricity and heat of the materials? [1m]

ANSWER SHEET

EXAM PAPER 2010

SCHOOL : ROSYTH PRIMARY
 SUBJECT : PRIMARY 6 SCIENCE

TERM : PERLIMINARY

| | | | | | | | | | | | | | | | | |
|----|----|----|----|----|----|----|----|----|-----|-----|-----|-----|-----|-----|-----|-----|
| Q1 | Q2 | Q3 | Q4 | Q5 | Q6 | Q7 | Q8 | Q9 | Q10 | Q11 | Q12 | Q13 | Q14 | Q15 | Q16 | Q17 |
| 3 | 4 | 1 | 1 | 2 | 2 | 4 | 4 | 2 | 2 | 2 | 3 | 2 | 2 | 1 | 3 | 3 |

| | | | | | | | | | | | | |
|-----|-----|-----|-----|-----|-----|-----|-----|-----|-----|-----|-----|-----|
| Q18 | Q19 | Q20 | Q21 | Q22 | Q23 | Q24 | Q25 | Q26 | Q27 | Q28 | Q29 | Q30 |
| 3 | 3 | 3 | 2 | 1 | 3 | 3 | 2 | 1 | 3 | 3 | 4 | 2 |

31)a) In pot N, there was overcrowding of the seedling, hence the competition for sunlight was more intense than M, so the seedlings will grow taller and thinner to obtain sufficient sunlight.

b) The plants in pot M have more space/less overcrowding/nutrients and water to grow,

c) Plants disperse their seeds far away from the parent plant to prevent overcrowding .

32)a) The chemical on the wheat plant would be transferred into the grasshopper when it eats it. The sparrow eats more grasshopper, so more chemical will be stored in its body. The python eats more sparrows and so the most amount of chemical will be accumulate in its body.

b)

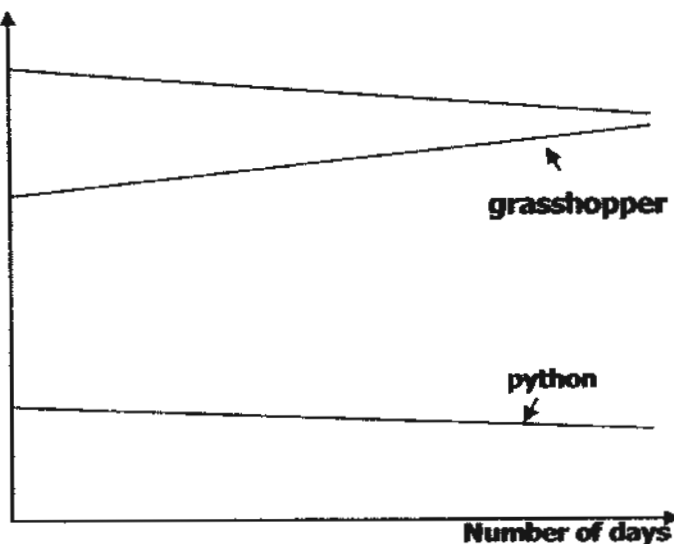

33)a)The decrease in the plant eater is not caused by the shortage of food but due to the animals eating them.

b)Z. It is eaten by both X and Y.

34)a)The rate of photosynthesis is highest in Q, followed by R and in sample P.

b)P. Sunlight is blocked by the algae on the surface of the water which prevented/reduced photosynthesis of submerged plants such as hydrilla from taking place and hence, the amount of oxygen produced.

35)a)

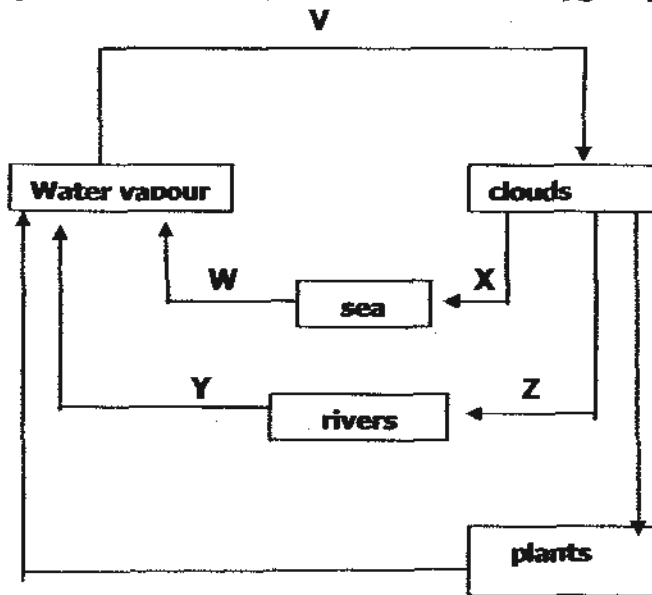

b)i)X and Z. ii)V

c)It part heat/increase the temperature so that it enables the water in the sea to evaporate.

36)a)The air taken in is higher in oxygen than the air that is given out and the air that is given out is warmer and moister than the air taken in.

b)The water vapour given out loses heat to the mirror and condenses on its cooler surface to form water droplets.

c)The water vapour in the air and the mirror are of the same temperature/ The water vapour cannot lose heat to the mirror to condense as both are of the same temperature.

37)a)

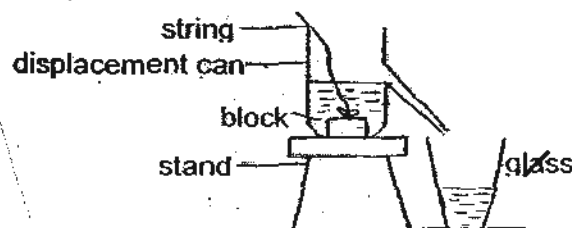

Diagram B

37)b) Pour the water in the glass into a measuring cylinder to measure the volume of water that was displaced.

c) It occupies space and has definite volume.

38)a) To find out the absorbance of water for each material.

b) Yes. All the variables in her experiment were kept the same, except for the material that she is testing.

c) C. It has the highest absorbance of water among the three materials and hence she can dry herself very quickly.

39)a) i) Iron plate ii) magnetic poles

b) The door would not be able to stay close with the plastic case. Aluminum is a non-magnetic material and hence the magnet could not attract it.

40)a) Gravitational force.

b) The gravity will pull him and the bicycle down as he is travelling upwards, thus he has to apply greater force to be able to overcome both the gravity and friction.

41)a) 40g.

b) The spring is elastic and can be stretched.

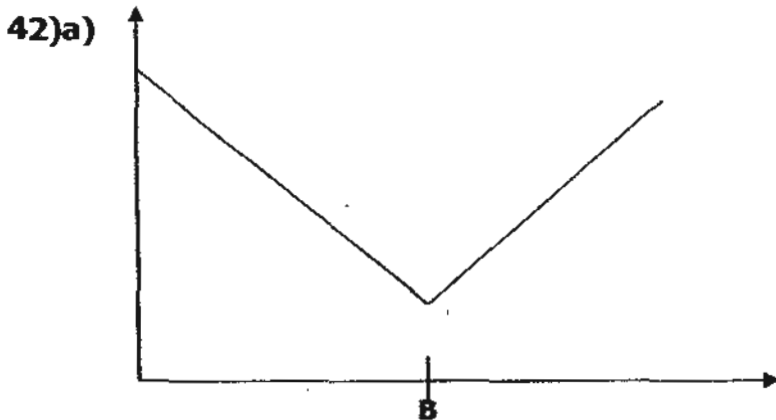

b) The ball would not reach its original as air resistant is acting on the ball thus would not allow the ball to go back to the same height at A after the round of swing.

43)a)

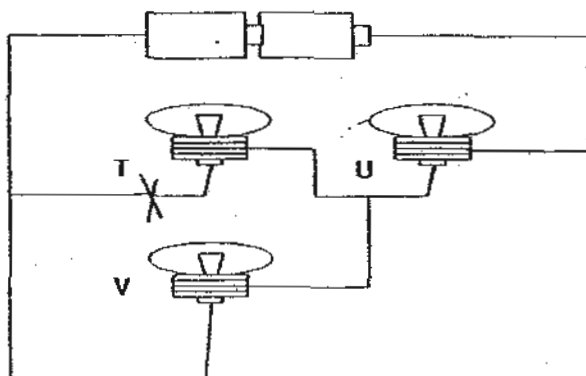

43)b)Each bulb can function independently even if 1 bulb fuses.

c)All the bulbs will not light up.

d)When V fuses, the circuit will be opened and electricity will not be able to flow through to light the other bulbs.

44)a)W. It is a non-conductor of electricity hence electricity cannot pass through the circuit and the bulb did not light up causing an open circuit.

b)Z is the best conductor of heat, followed by X, Y and then W.

c)If the material is a good conductor of electricity, it would also mean that it is a good conductor of heat.