

Index Number:

--	--	--	--	--	--

CHIJ ST. NICHOLAS GIRLS' SCHOOL



PRELIMINARY EXAMINATION

2010

P6 SCIENCE

(BOOKLET A)

26 August 2010

NAME : _____ ()

CLASS : Primary 6 _____

Total time for Booklets A & B: 1 hour 45 minutes

30 questions
60 marks

INSTRUCTIONS TO CANDIDATES

- Do not open this booklet until you are told to do so.
- Follow all instructions carefully.
- Answer all questions.

This booklet consists of 25 printed pages.

Section A (30 x 2 = 60 MARKS)

For each question from 1 to 30, four options are given. One of them is the correct answer. Make your choice (1, 2, 3 or 4). **Shade the correct oval (1, 2, 3 or 4) on the Optical Answer Sheet.**

1. The following table gives information on four plants, R, S, T and U, based on two characteristics. A tick (✓) shows that the plant has the characteristic.

Plant \ Characteristic	R	S	T	U
Bear fruit		✓	✓	
Grow in water	✓		✓	

From the information above, where do plants R, S, T and U belong to in the following classification chart?

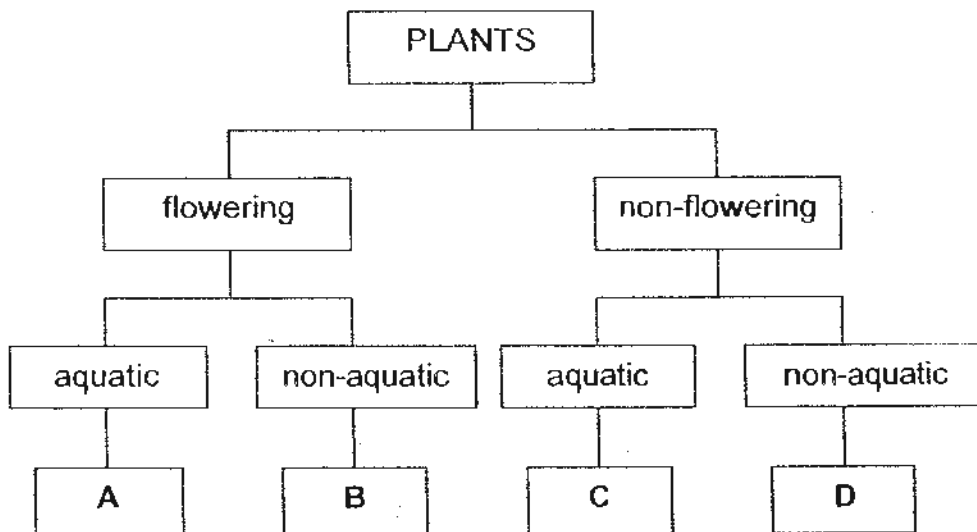

	Plant R	Plant S	Plant T	Plant U
(1)	D	B	C	A
(2)	C	A	B	D
(3)	A	D	C	B
(4)	C	B	A	D

2. The diagrams below show the relationship between the number of producers and consumers in two food chains.

Producer → Primary consumer → Secondary consumer

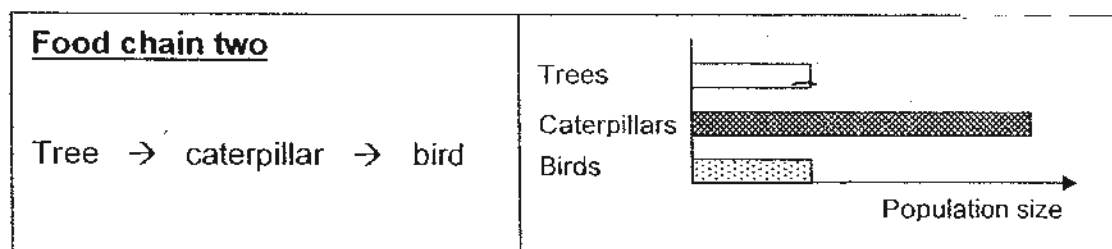
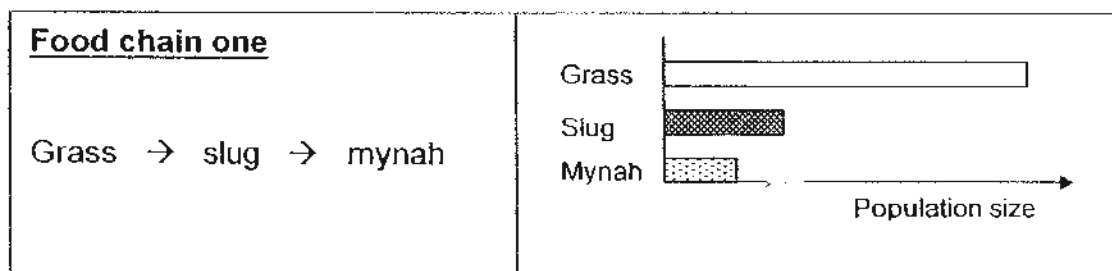

Which one of the following statements is supported by the information above?

- (1) Primary consumers are usually insects that eat plants.
- (2) Primary consumers are larger than secondary consumers.
- (3) There are more primary consumers than there are producers.
- (4) There are more primary consumers than there are secondary consumers.

3. The table below shows the characteristics of some flowers which attract specific animals.

Animal	The characteristics of flowers that mainly attract the animals		
	Size	Colour	Smell / Odour
bee	small	bright blue or yellow	-
beetle	large	white	spicy
butterfly	small	white	-
bird	large	red or yellow	-
bat	large	white	fruity

The flow chart below classifies six flowers A to F according to their characteristics.

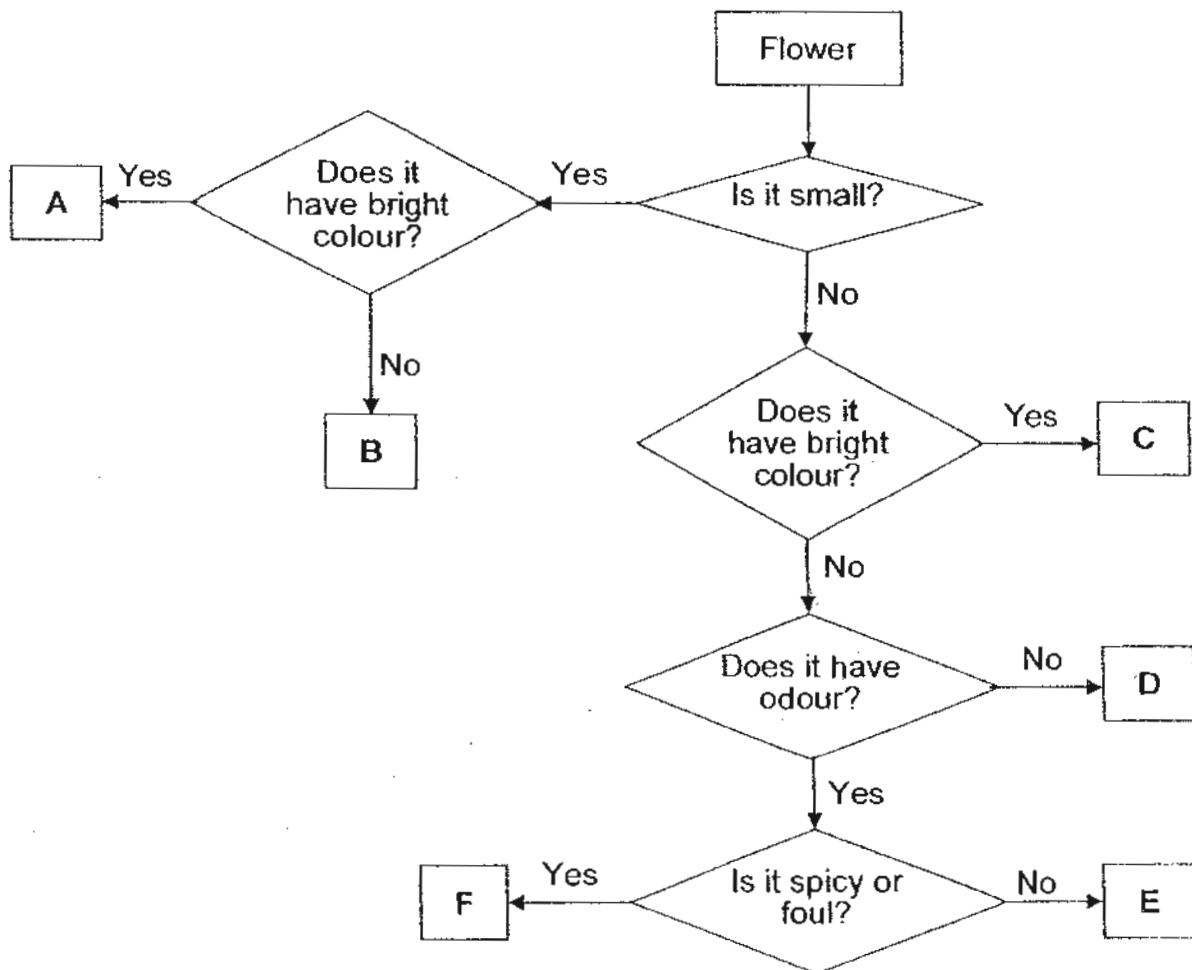

Which one of the following lists shows the animals that will be attracted to flowers A, C, D and E respectively?

	Flower A	Flower C	Flower D	Flower E
(1)	bee	bird	beetle	bat
(2)	bird	bee	beetle	butterfly
(3)	butterfly	-	bird	bat
(4)	bee	bird	-	bat

4. Which of the following comparisons between the life cycles of a cat and a frog is/are correct?

Characteristics	Cat	Frog
A: Has three stages in the life cycle	Yes	Yes
B: Moults several times as it grows	No	Yes
C: Resembles its parents when young	Yes	No
D: The young eats the same food as the adult	Yes	Yes

- (1) B only
(2) A and B only
(3) A and C only
(4) B, C and D only
5. Penguins are warm-blooded animals.



Which of the following are structural adaptations that enable them to live in the cold Antarctic?

- A Wings modified into flippers
B Thick layer of fat under the skin
C Puffing up the feathers to trap air
D Closely-packed overlapping feathers
- (1) A and B only
(2) B and D only
(3) A, C and D only
(4) B, C and D only

6. Mr Wong carried out different activities over a period of time. The graphs below show the different pulse rates while he was engaging in different activities.

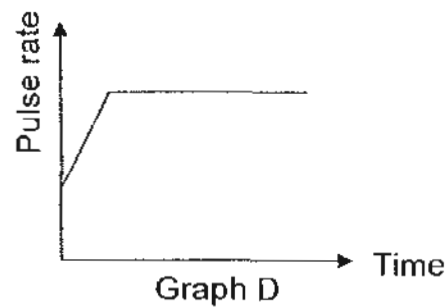
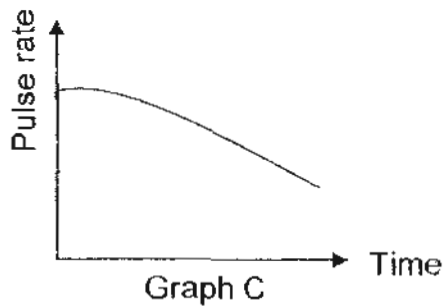
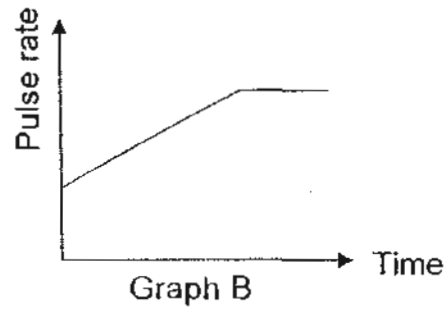
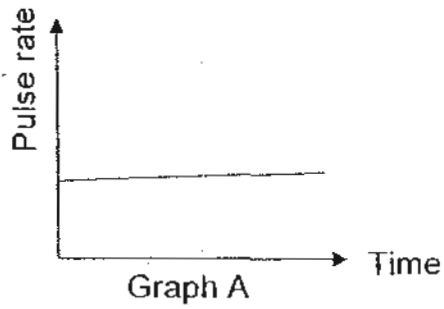

Which one of the following lists shows the activities that match the graphs A, B, C and D respectively?

	Graph A	Graph B	Graph C	Graph D
(1)	Reading a book	Jogging	Resting after a run	Sprinting
(2)	Reading a book	Sprinting	Resting after a run	Jogging
(3)	Sprinting	Jogging	Reading a book	Resting after a run
(4)	Resting after a run	Jogging	Reading a book	Sprinting

7. The diagram below shows four animals. Alan classified them into two groups. In each group there were exactly two animals.

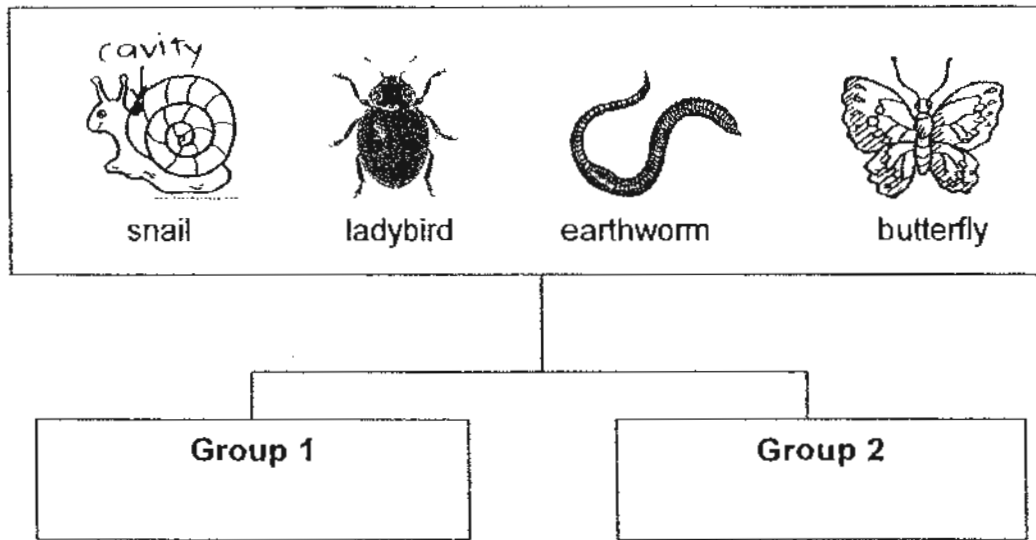

Which of the following ways of grouping could he get exactly two animals in each group?

	Group 1	Group 2
A	Can fly	Cannot fly
B	Insects	Non-insects
C	Breathe through skin	Breathe through breathing holes
D	Body divided into segments	Body has no segment

- (1) A and B only
- (2) C and D only
- (3) A, B and D only
- (4) A, B, C and D

8. Mr Brown ploughed a field, removed all the weeds growing in the field and then left it for some time. On the edge of the field, untouched by the plough, were three different plants, R, S and T.

The diagram below shows his field.

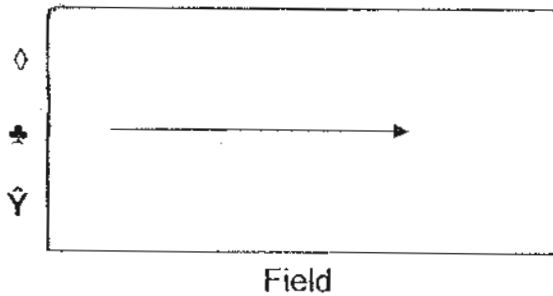

Key

- Wind direction
- ◇ Plant R: Seeds with hair-like structure.
- Y Plant S: Pods split open when ripe.
- ♣ Plant T: Has fleshy fruits with big seeds.

When Mr Brown returned a month later, the three plants had spread across his field. There were 9 Plant R, 7 Plant S and 5 Plant T. Which one of the following diagrams shows the most likely way these plants were spread across his field?

(1)

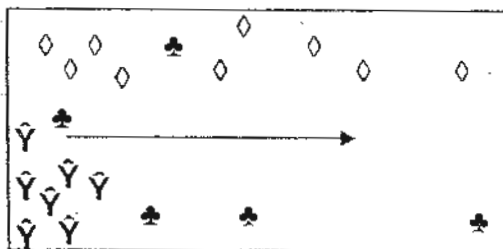

(2)

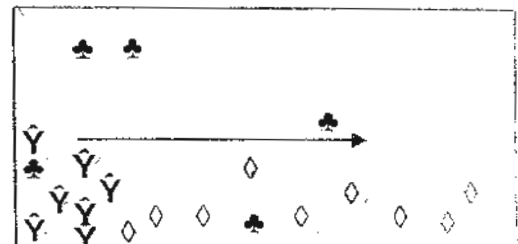

(3)

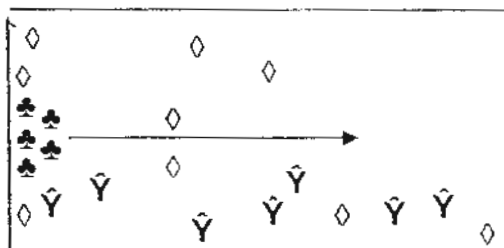

(4)

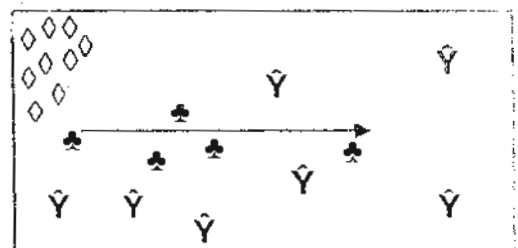

9. The table below gives information about the temperature at which crops will grow.

Crop	Minimum temperature (°C)	Optimal temperature (°C)	Maximum temperature (°C)
Corn	20	22 – 25	34
Potato	12	15 – 20	34
Rice	18	30 – 33	40
Wheat	5	20 – 25	38

Which one of the graphs below best represents potato?

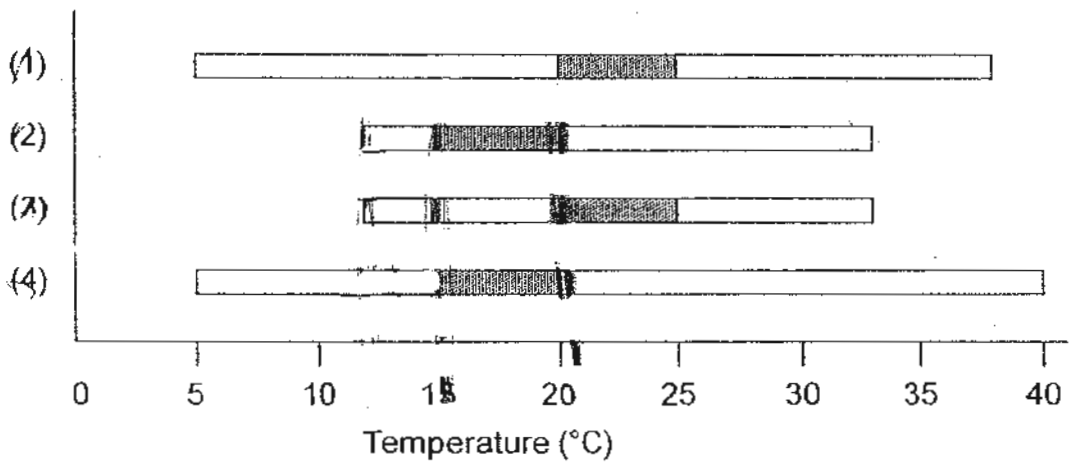
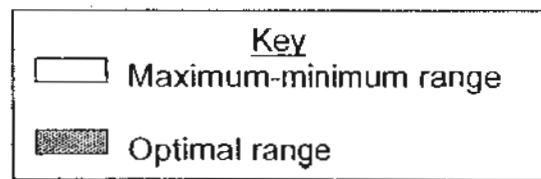

10. The diagram below shows how living things exchange gases with the environment.

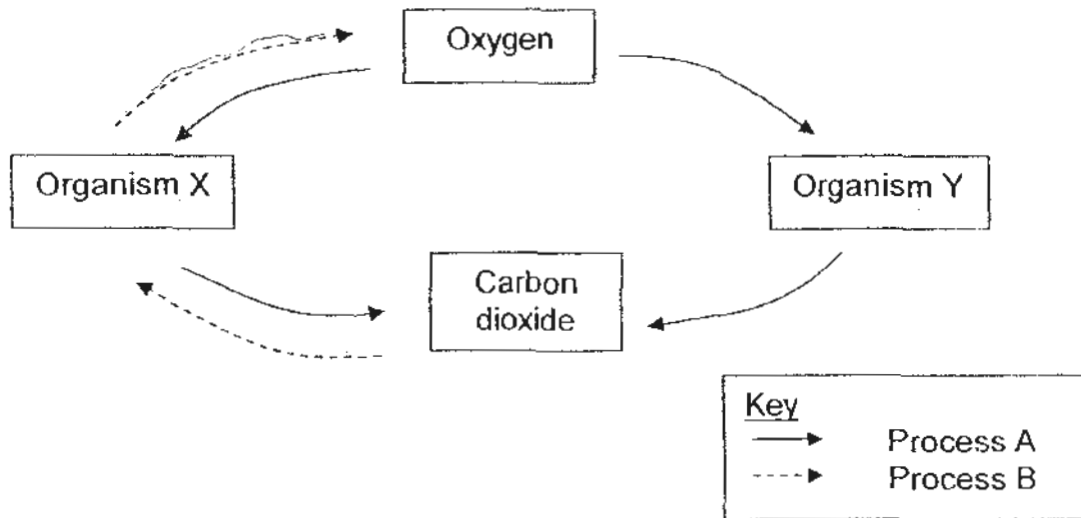

Which one of the following statements is **not** correct?

- (1) Organism X could be algae.
 - (2) Process A takes place all the time.
 - (3) Process B takes place all the time.
 - (4) Water is needed for process B to take place.
11. The graph below shows the stages in the life cycle of an insect and the length of time the insect remains at each stage of its life cycle.

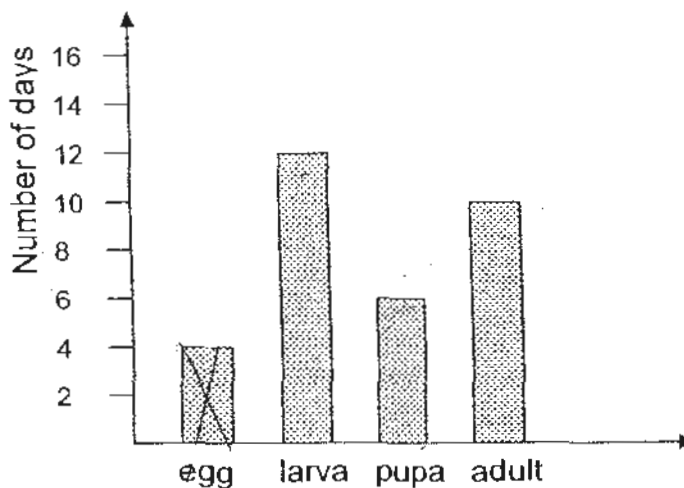

How many days does the insect take to become an adult after the egg has hatched?

- (1) 16 days
- (2) 18 days
- (3) 22 days
- (4) 28 days

12. The chart below shows Siti's family tree.

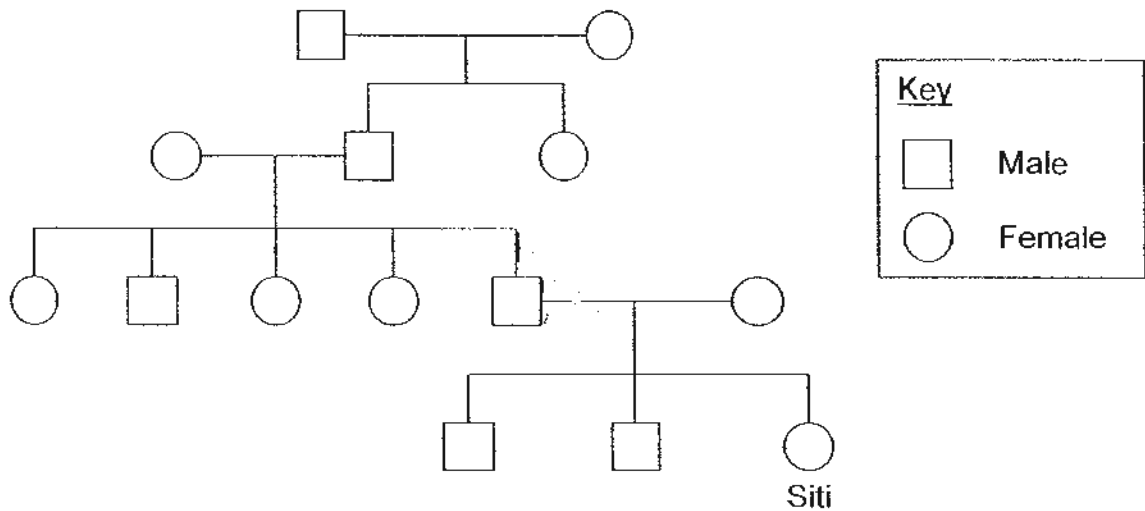

Based on the chart above, which one of the following statements about Siti's family tree are we sure of?

- (1) Siti has two uncles.
- (2) Siti's father has three sisters.
- (3) Siti's great-grandparents have three children.
- (4) Siti has two brothers, one younger and one older.

13. Bacteria M are added to turn milk into yoghurt within eight hours. The ideal number of bacteria M to make yogurt ranges from 65 to 85. The table below shows the number of Bacteria M present in the milk at different temperatures over a period of time.

Temperature	Number of Bacteria M present in the mixture	
	0h	8h
20 °C	10	33
25 °C	10	36
30 °C	10	40
35 °C	10	73
40 °C	10	80
45 °C	10	76
50 °C	10	43

Alan added some Bacteria M into a bottle of milk. Based on the table above, which temperature range should Alan keep the milk and bacteria mixture in order for it to turn into yoghurt within 8 hours?

- (1) 25 °C to 30 °C
- (2) 32 °C to 36 °C
- (3) 36 °C to 40 °C
- (4) 44 °C to 48 °C

14. Four cages of fish, W, X, Y and Z, were placed in different parts of a river, as shown in the diagram, to study water pollution.

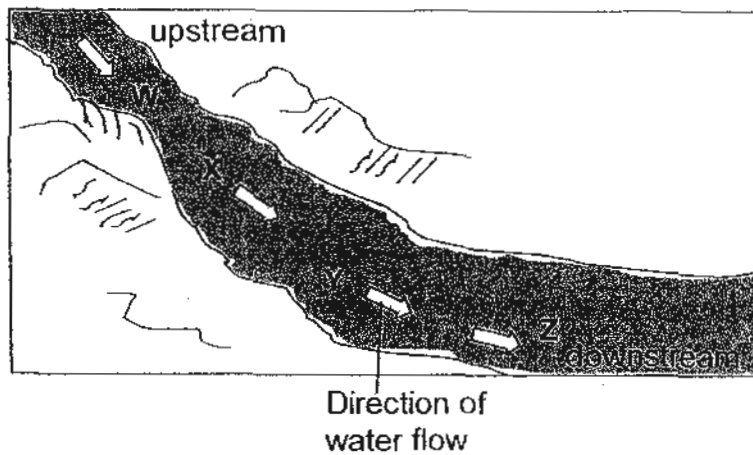

The table below shows the results obtained from the study.

	Cage W	Cage X	Cage Y	Cage Z
Number of fish at the start of study	30	20	30	20
Depth at which the cage was placed in the river	1 metre	2 metres	2 metres	1 metre
Number of fish alive at the end of study	20	12	25	11

Based on the results obtained from the study, which one of the following conclusions is correct?

- (1) Water upstream is not polluted.
- (2) Water deeper in the river is less polluted.
- (3) Water downstream is as polluted as upstream.
- (4) Water downstream is more polluted than water upstream.

15. The graphs below show the concentrations of different pollutants detected in air samples at six monitored sites.

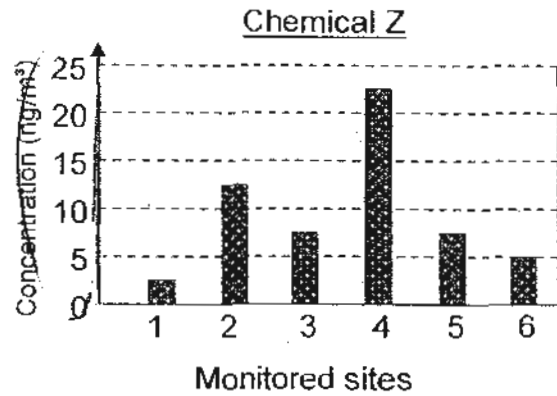
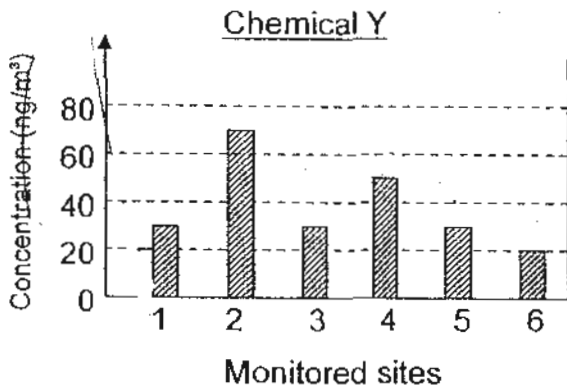
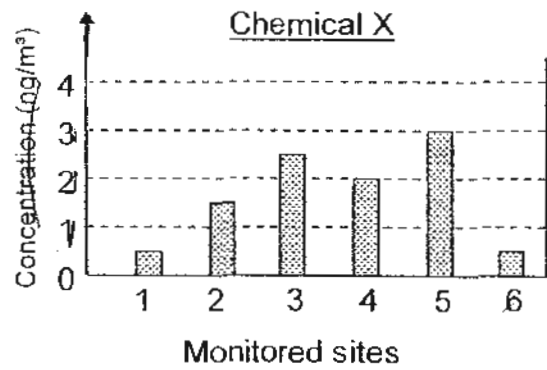
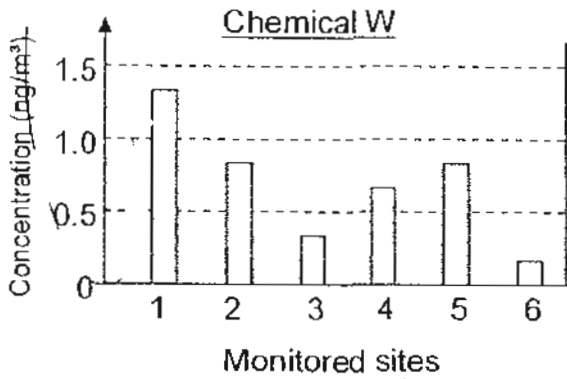

Which pollutant is present in the highest concentration?

- (1) Chemical W
- (2) Chemical X
- (3) Chemical Y
- (4) Chemical Z

16. The flow chart below shows how some items are classified.

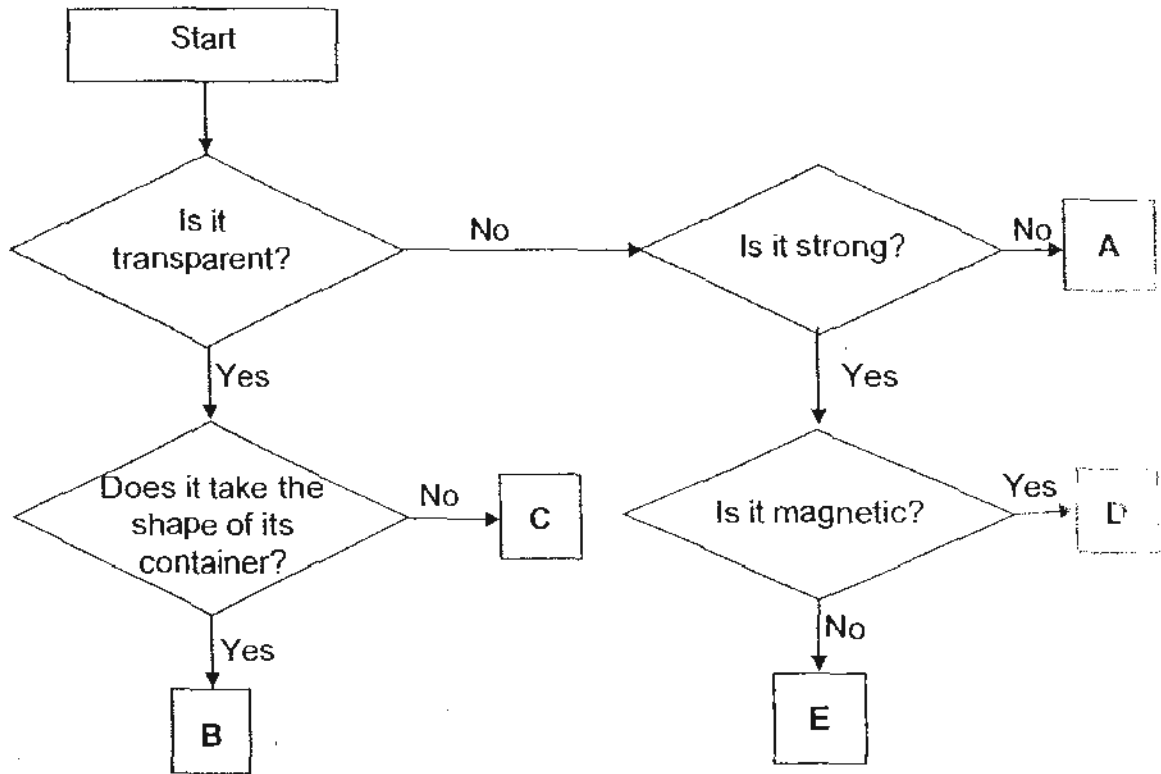

Which set of items correctly matches the exit points A, B, C, D and E?

	A	B	C	D	E
(1)	ceramic pot	clear plastic	frosted glass	iron nail	iron rod
(2)	frosted glass	tissue paper	water	zinc rooftop	copper wire
(3)	paper towel	water	mirror	steel rod	aluminium tray
(4)	styrofoam	alcohol	transparency	iron nail	copper rod

17. Study the following diagram.

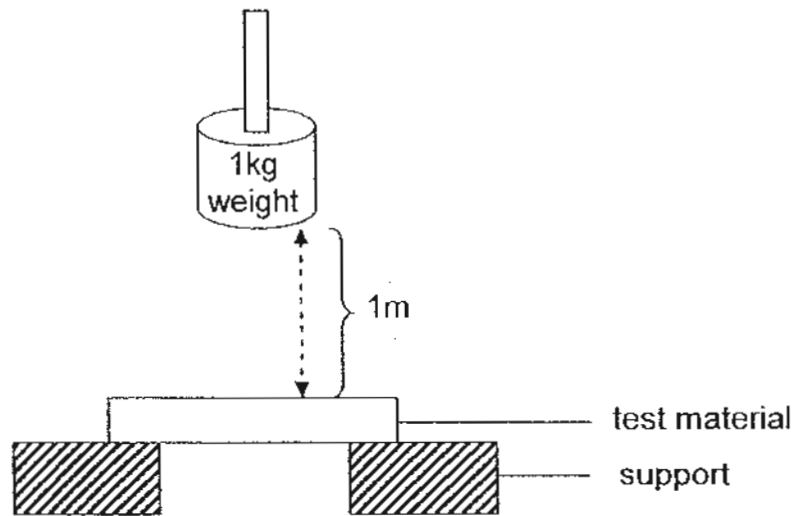

Sonia tested the strength of five materials by dropping a 1kg weight from a height of 1m. The materials were of the same size and shape. She noted the number of times the weight was dropped before the materials broke. Her results are shown below.

Material	Number of hits to break the material
A	40
B	28
C	52
D	19
E	46

Based on the results in the table above, Sonia made the following conclusions:

- A Material C is a metal.
- B Material A is stronger than material E.
- C Material B is hard enough to scratch material D.
- D Material D is the first one to break if a 2-kg weight is used to repeat the experiment.

Which of the above conclusions made by Sonia is/are correct?

- (1) A only
- (2) D only
- (3) A and B only
- (4) C and D only

18. The table below shows the melting and boiling points of substances P, Q and R respectively.

Substance	Melting point (°C)	Boiling point (°C)
P	42	83
Q	28	64
R	58	93

At which one of the following temperatures are the three substances P, Q and R at the same state?

- (*) 31°C
 (2) 48°C
 (3) 61°C
 (4) 80°C
19. Hannah put three identical towels containing the same amount of water in the balcony to dry. Each towel was folded such that the exposed surface areas of the towels were different. After 4 hours, each towel was weighed. Hannah then recorded her results and plotted them on a graph.

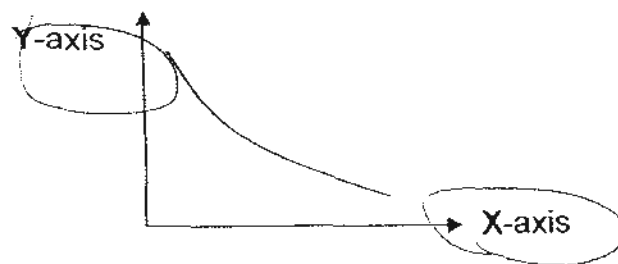

Which one of the following pairs of labels is most suitable for the X and Y axes of the graph?

	X-axis	Y-axis
(1)	Time taken	Mass of towels
(2)	Surface area of towels	Time taken
(3)	Time taken	Surface area of towels
(4)	Surface area of towels	Mass of towels

20. The diagram below shows a metal rod with four similar blobs of wax, E, F, G and H, attached to it.

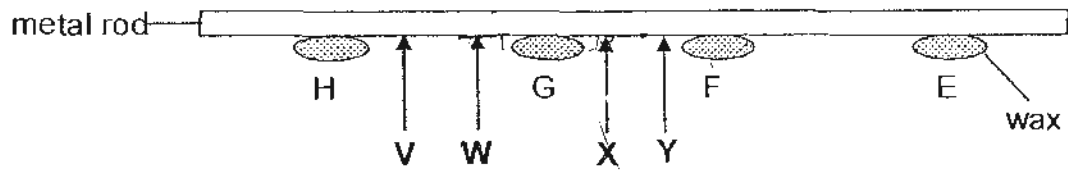

When the metal rod was heated by a candle flame placed below it, the blobs of wax melted in the order, G, F, H and then E.

At which part of the metal rod, V, W, X or Y, was the candle flame placed?

- (1) V
- (2) W
- (3) X
- (4) Y

21. Bee Eng set up the following circuit.

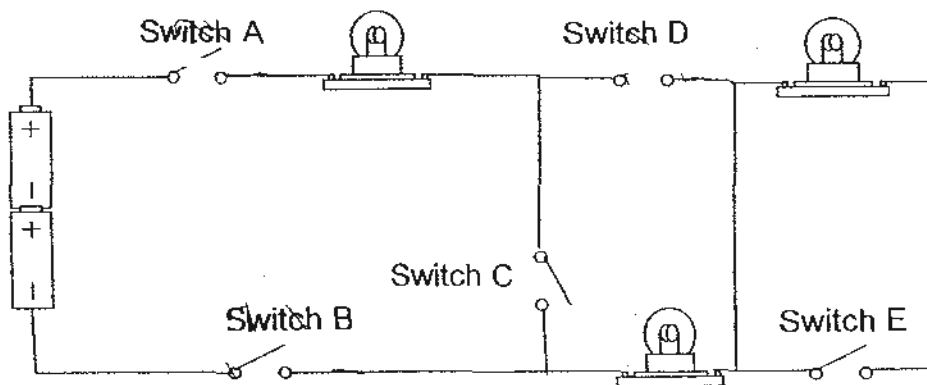

She wanted to light up only two bulbs, which switches should she close?

- (1) A, B and D only
- (2) A, C and D only
- (3) A, B, D and E only
- (4) B, C, D and E only

22. Zoe had three rods, X, Y and Z, of unknown materials. She tested their electrical conductivity by placing them at positions P, Q and R, as shown in the circuit below.

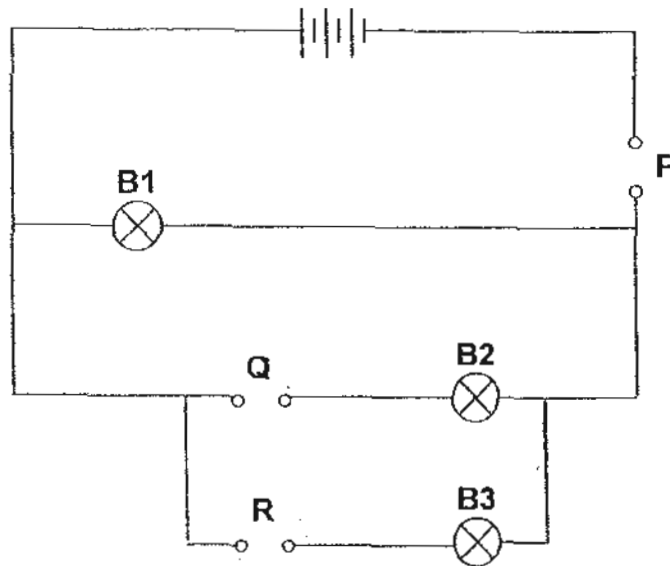

The results of the experiment were shown in the table below.

Position	P	Q	R
Rod	X	Y	Z
Bulb	B1	B2	B3
Bulb lights up?	Yes	No	Yes

She then repeated the experiment by placing the rods at different positions as shown in the table below.

Position	P	Q	R
Rod	Y	Z	X

Which one of the following shows correctly whether the bulbs light up or not?

	Bulb 1	Bulb 2	Bulb 3
(1)	Yes	Yes	No
(2)	Yes	No	Yes
(3)	Yes	Yes	Yes
(4)	No	No	No

23. A metal bar AB is suspended by a thin thread. It always comes to rest with one end of the bar, A, pointing north as shown in Figure 1 below. Another bar GH, as shown in Figure 2, is made of the same metal as AB and it settles in no definite direction.

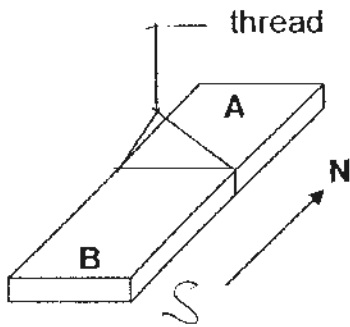

Figure 1

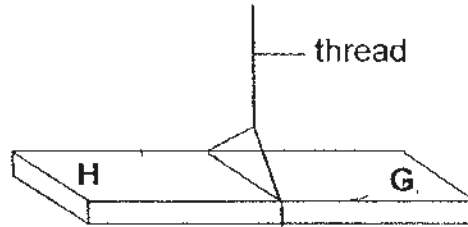
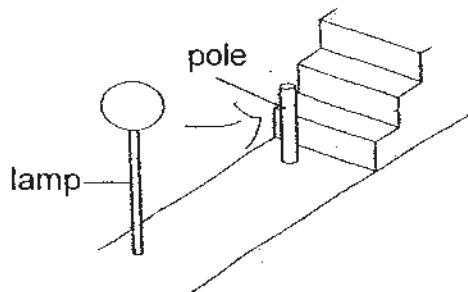

Figure 2

What happens when the two metal bars are brought near to each other?

- (1) Both ends, A and B, attract end G.
 - (2) End B repels end G but attracts end H.
 - (3) End A attracts end G but repels end H.
 - (4) End B neither attracts nor repels end G.
24. A pole is placed in front of a flight of steps. A lamp is shining onto the pole as shown.



Which diagram below shows the correct shadow of the stick?

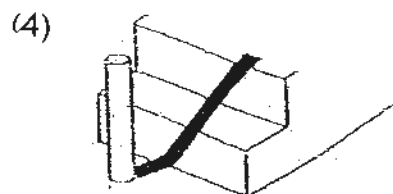
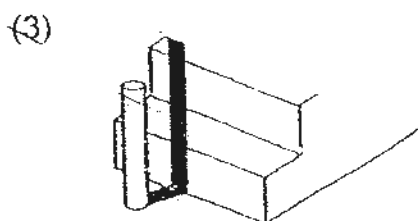
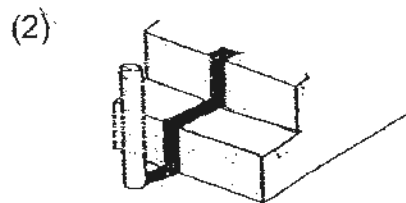
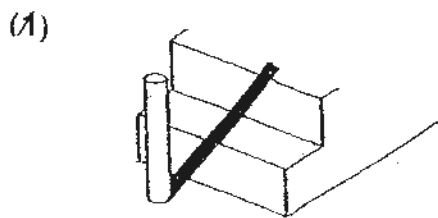

25. Ronald used the set-up as shown below to measure the length of a spring.

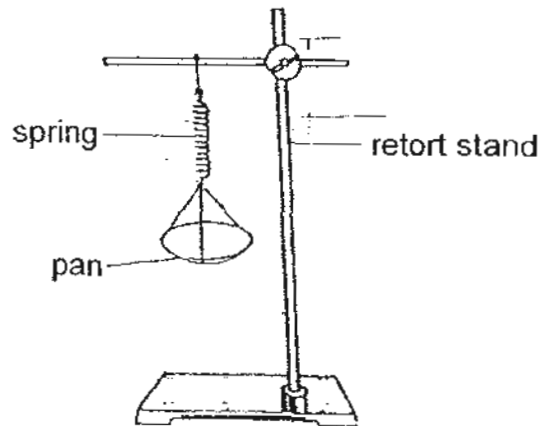

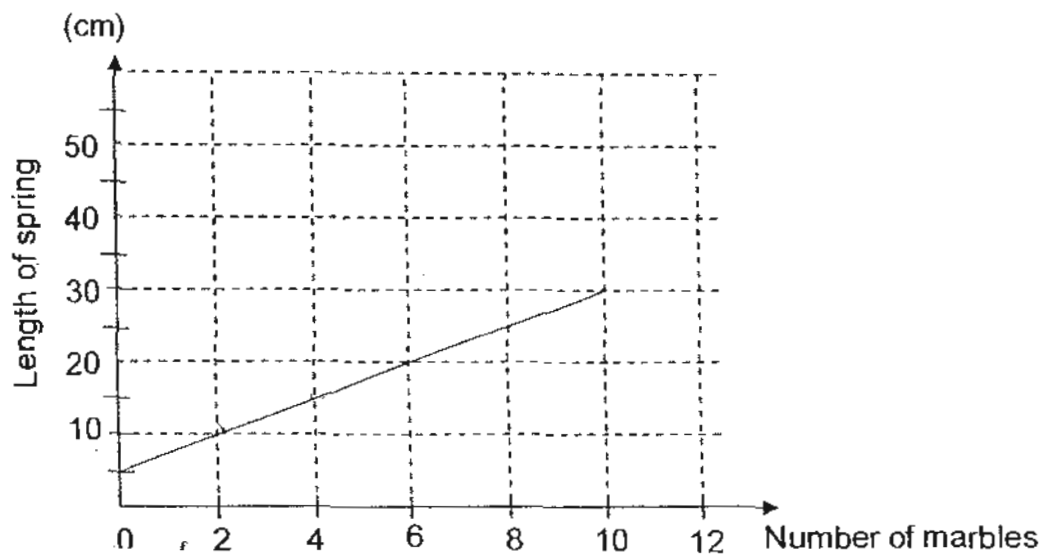

Each time a different number of marbles was placed on the pan, Ronald recorded the length of the spring and plotted a graph as shown below.



Based on the graph drawn by Ronald, what would the extension of the spring be if Ronald had placed 12 marbles on the pan?

- (1) 15cm
- (2) 20cm
- (3) 30cm
- (4) 35cm

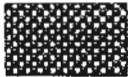
26. The table below shows the expansion of certain metals when heated to 100°C.

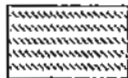
Key	Metal	Length of metal at room temperature	Length of metal at 100°C
	P	100mm	111mm
	Q	100mm	102mm
	R	100mm	106mm

Metals P, Q and R were used to make rings as shown below. The rings were immersed into water at 100°C for 10 minutes.

Which of the inner rings could be easily removed at the end of 10 minutes?

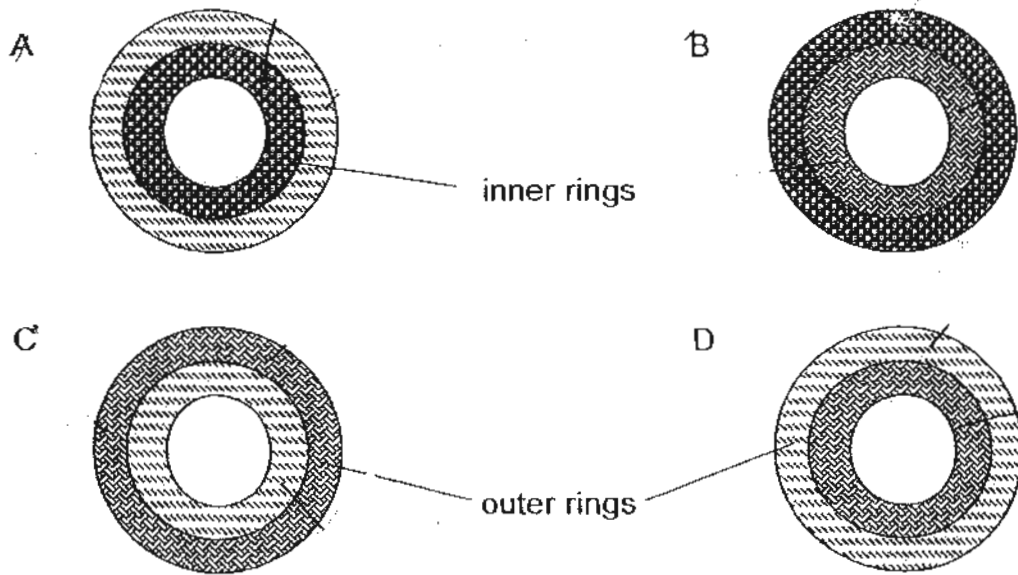

- (1) A and B only
- (2) C and D only
- (3) B and D only
- (4) A and C only

27. Aaron carried out the experiment as shown below. Water in the container drips out from a hole at the base onto a wheel held below it. Which wheel will turn the fastest?

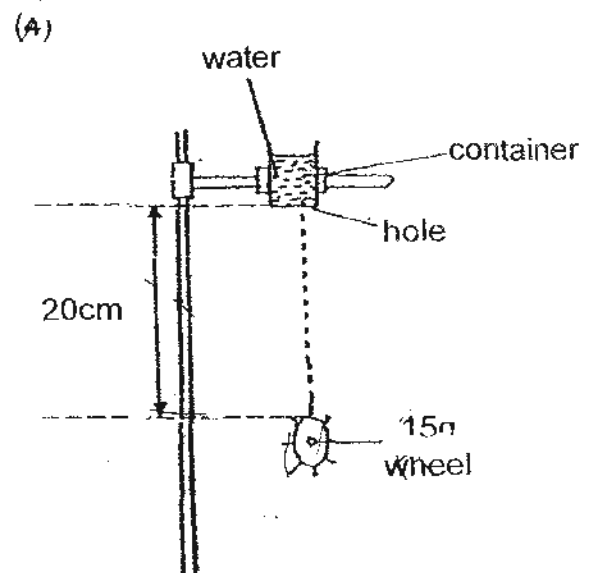
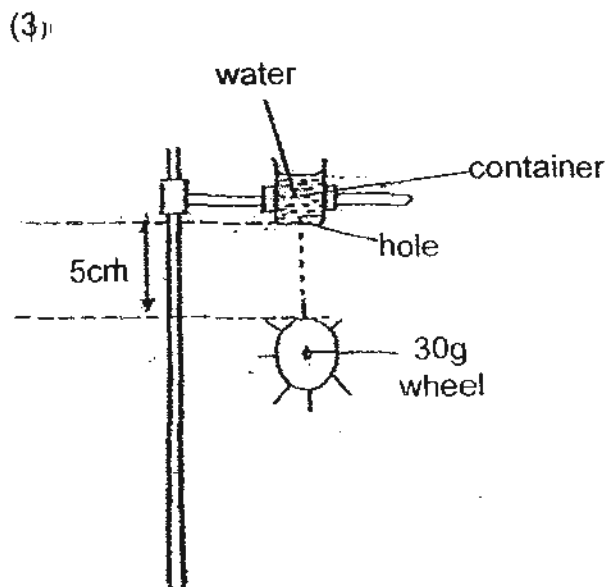
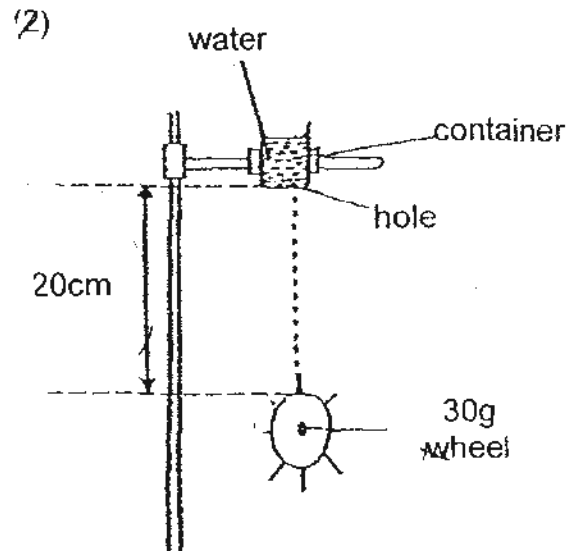
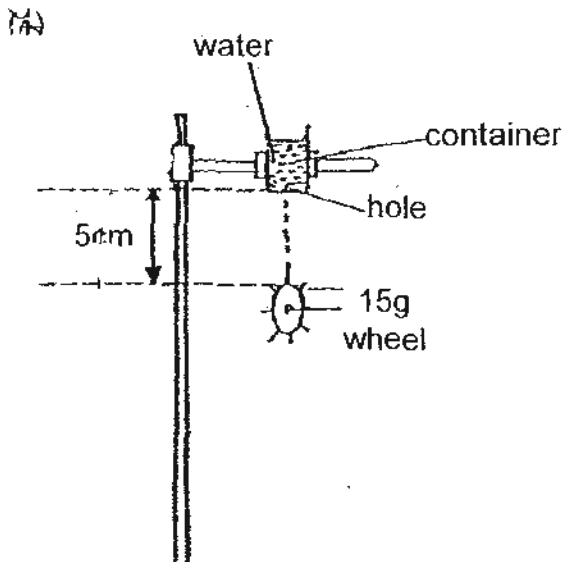

28. The diagram below shows a water container filled with 4500cm^3 of water. The capacity of the container is 10 litres. (1litre = 1000cm^3)

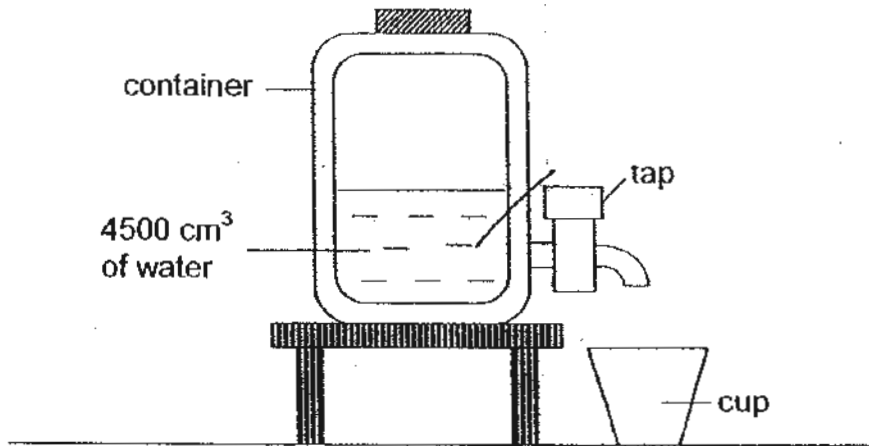

Joe turns on the tap of the container to fill his cup with 500cm^3 of water.

What is the final volume of the air in the container?

- (1) 5000 cm^3
- (2) 5500 cm^3
- (3) 6000 cm^3
- (4) 9500 cm^3

29. Inez carried out an experiment to find out how far a toy car would move on a tiled surface when the elastic band is pulled back to different distances. She stretched the elastic band before releasing it to slide the toy car across the tiled floor.

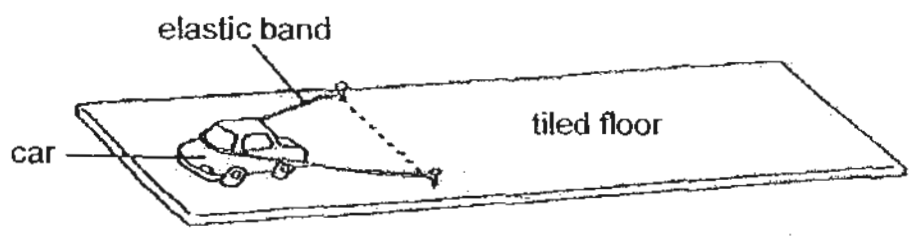

Which one of the following graphs best describes the relationship between the distance moved by the toy car and the distance the elastic band is pulled back?

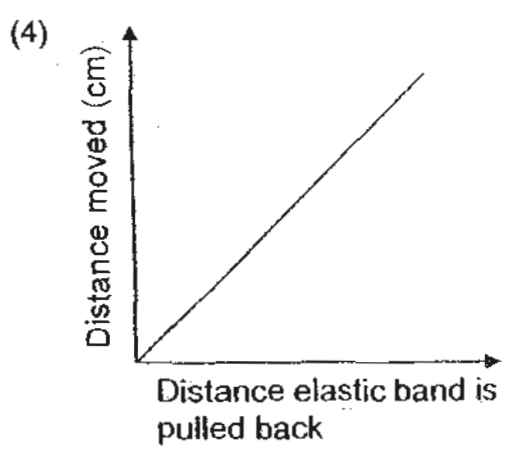
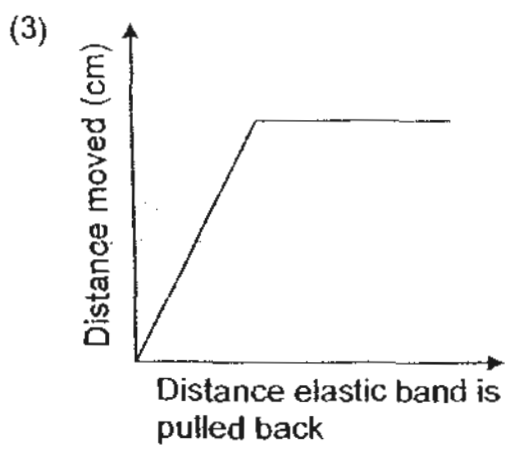
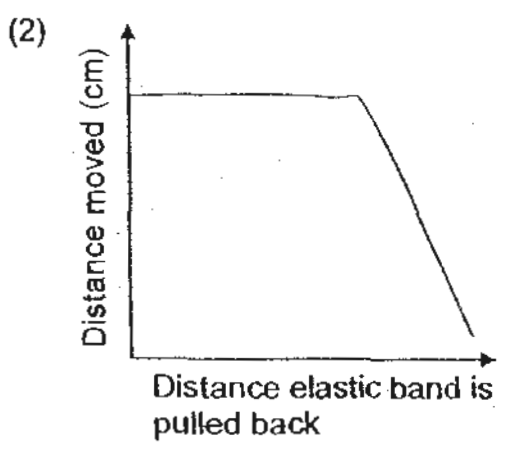
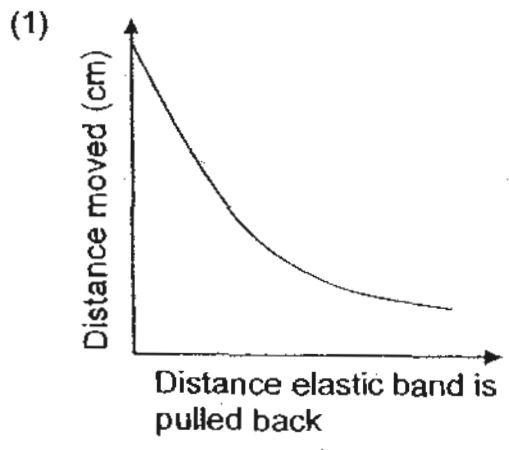

30. Some processes involving energy changes are listed below.

- A Burning of fossil fuels
- B A durian dropping from a tree
- C Rubbing of a rubber seed on the ground
- D Using wind to spin a windmill connected to a generator

Which one of the following diagrams correctly shows the energy changes in the processes above?

(A)

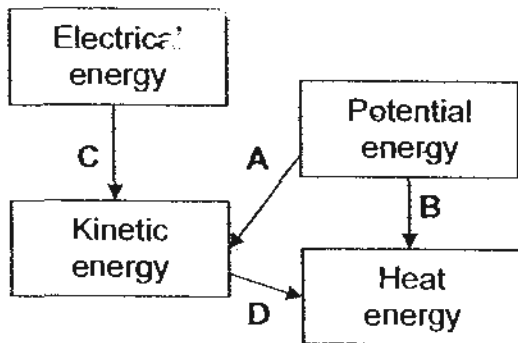

(B)

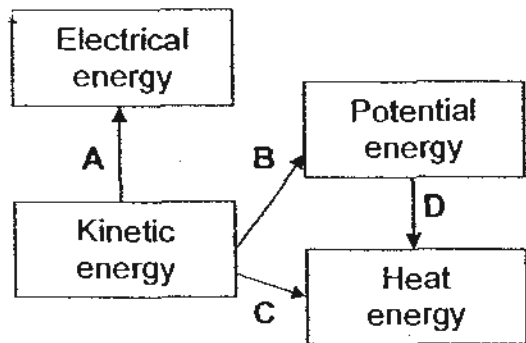

(C)

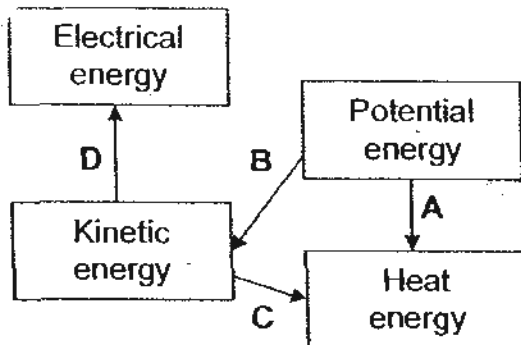

(D)

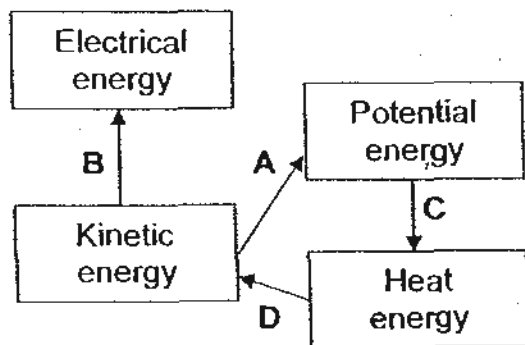

~~ End of Section A ~~

Index Number:

--	--	--	--	--	--	--

CHIJ ST. NICHOLAS GIRLS' SCHOOL



PRELIMINARY EXAMINATION

2010

P6 SCIENCE

(BOOKLET B)

26 August 2010

NAME : _____ ()

CLASS : Primary 6 _____

Total time for booklets A & B: 1 hour 45 minutes

14 questions
40 marks

INSTRUCTIONS TO CANDIDATES

- Do not open this booklet until you are told to do so.
- Follow all instructions carefully.
- Answer all questions and write your answers on this booklet.

Booklet A	60
Booklet B	40
Total	100

Parent's Signature/Date

This booklet consists of 15 printed pages.

Section B (40 marks)

For questions 31 - 44, write your answers in this booklet.
The number of marks available is shown in brackets [] at the end of each question or part question.

31. The diagram below shows the movement of water in a plant.

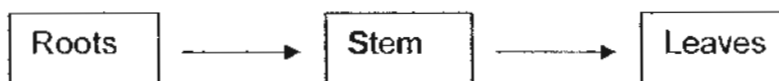

(a) (i) When water reaches the leaves, some of it will be used by the plant for photosynthesis. What happens to the rest of the water and how is this important to the plant? [2]

(ii) State one other reason why water is important to the plant. [1]

(b) The diagram below shows the circulatory system of a fish.

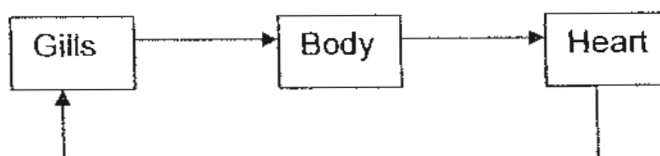

From the two diagrams above, state one difference between the transport system in a plant and the circulatory system of a fish. [1]

32. Wenjie placed a cell as shown in figure 1 below into a beaker of solution W. He then removed the cell and tested part X of the cell for the presence of solution W. He did not find any trace of solution W in part X.

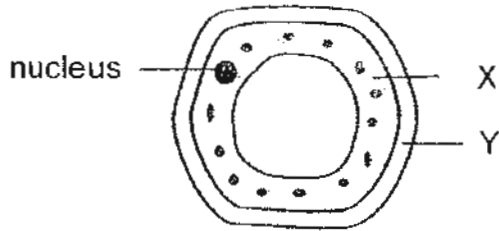

Figure 1

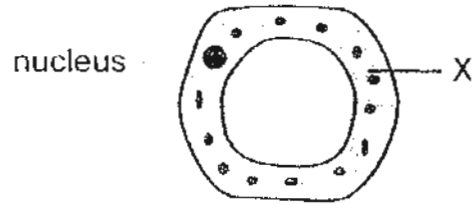

Figure 2

After the test he removed part Y of the same cell as shown in figure 2 and again placed the cell back into solution W. He removed the cell after some time and again tested part X of the cell for the presence of solution W.

- (i) Name the part of the cell that he had removed. [1]

- (ii) Would he find traces of solution W in his second test? Explain your answer. [1]

33. The diagram below shows the life cycle of a mealworm beetle.

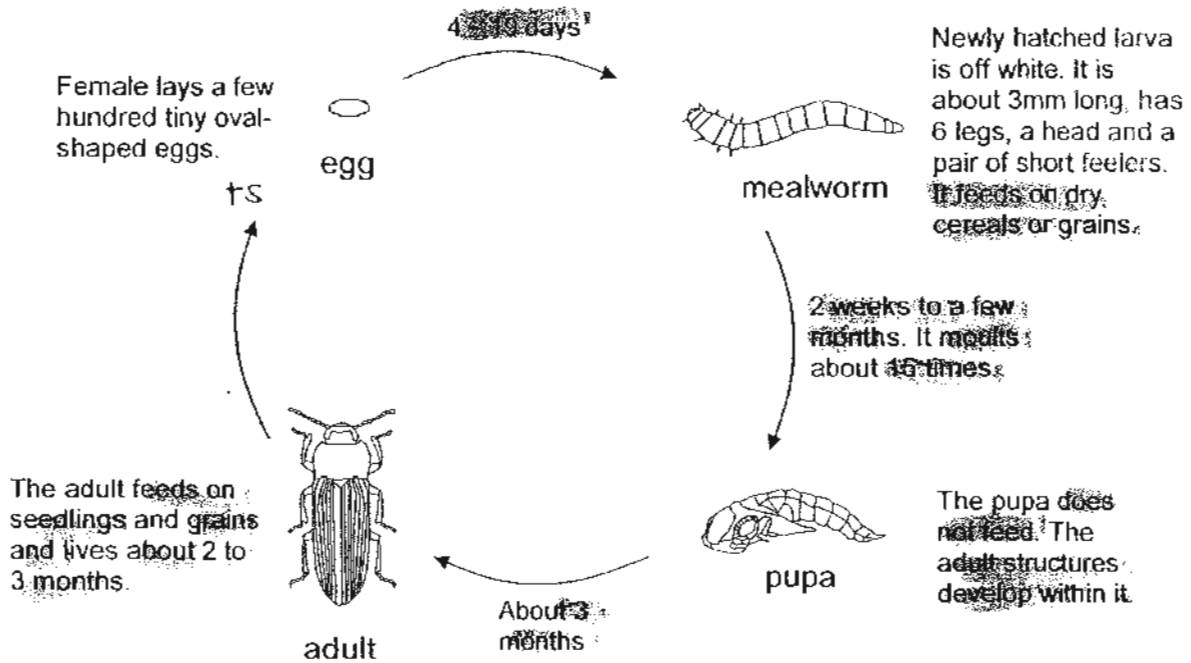

(a) "Mealworms are regarded as pests by some people but to ^{others} others they are regarded as very useful." Explain the above statement by citing examples. [2]

(b) Based on the information given in the diagram above, state whether each of the following statements is True (T), False (F) or Not Possible (NP) to tell. [2]

	Statement	Answer
(i)	The pupa moults about 15 times as it grows bigger.	
(ii)	The larva may take up to 3 months before it changes into a pupa.	
(iii)	The mealworm is the larval stage of an insect.	
(iv)	The adult mealworm beetle prefers rice grains to seedlings.	



34. The graph below shows the percentage of carbon dioxide within a greenhouse for two separate days.

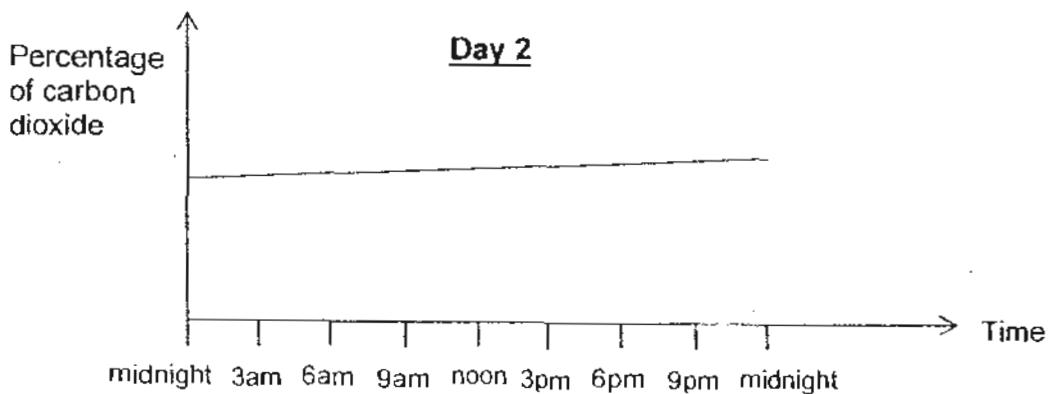
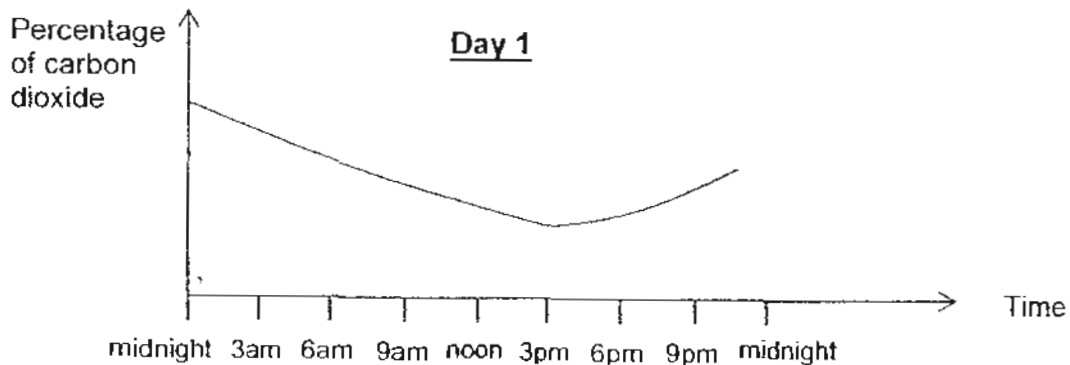

- (i) At what time was the rate of photosynthesis the highest on Day 1? [1]

- (ii) The percentage of carbon dioxide in the greenhouse on Day 2 was quite constant throughout the day even though the conditions in the greenhouse were not changed. Give a possible reason. [1]



35. The diagram below shows the human digestive system.

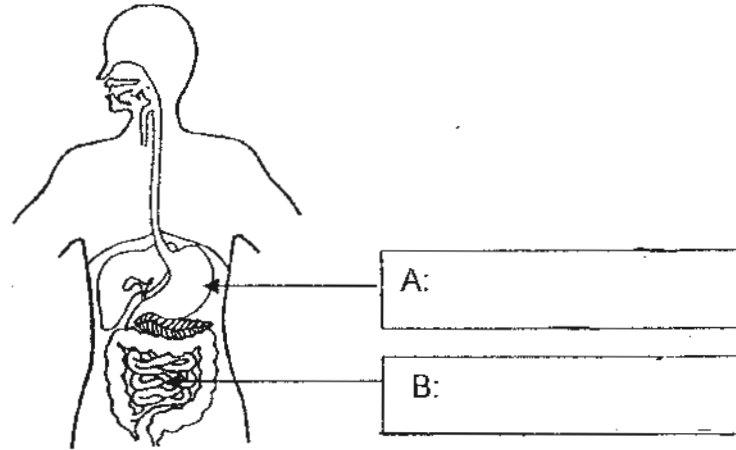

(a) Label part A and part B. [1]

(b) State one similarity and one difference between the two organs. [2]

Similarity: _____

Difference: _____

36. Study the food web below carefully.

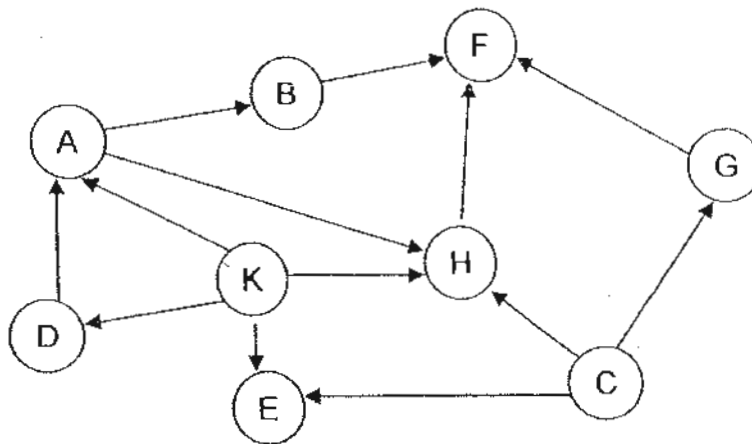

(a) Name the food source(s) in the food web. [1]

(b) From the food web above, write down two food chains with five types of organisms each. [2]

(i) _____

(ii) _____



37. The table below shows some aquatic animals and the amount of oxygen they need to live in water.

Animal	Amount of oxygen needed
Bloodworm	Little
Mayfly nymph	Large
Caddisfly larva	Moderate
Rat-tailed maggot	Very little

Hanwei collected four samples of water from a stream at different locations and examined the animals in the water. He recorded his observations in the table below.

Water sample	Animal found
W	Caddisfly larva
X	Mayfly nymph
Y	Rat-tailed maggot
Z	Bloodworm

Using the information provided above, arrange the four samples of water, W, X, Y and Z, from the least polluted to the most polluted in the boxes below. [2]

Least polluted
←
→
 Most polluted

--	--	--	--



38. An experiment was set up to find out which material is most suitable for making a towel. Strips of materials, A, B, C and D, of the same size were all dotted with water soluble ink and left to hang in a trough of water as shown in the diagram below. The water absorbed by the materials would travel upwards and smudge the dots along the length of the strips creating blotches of ink.

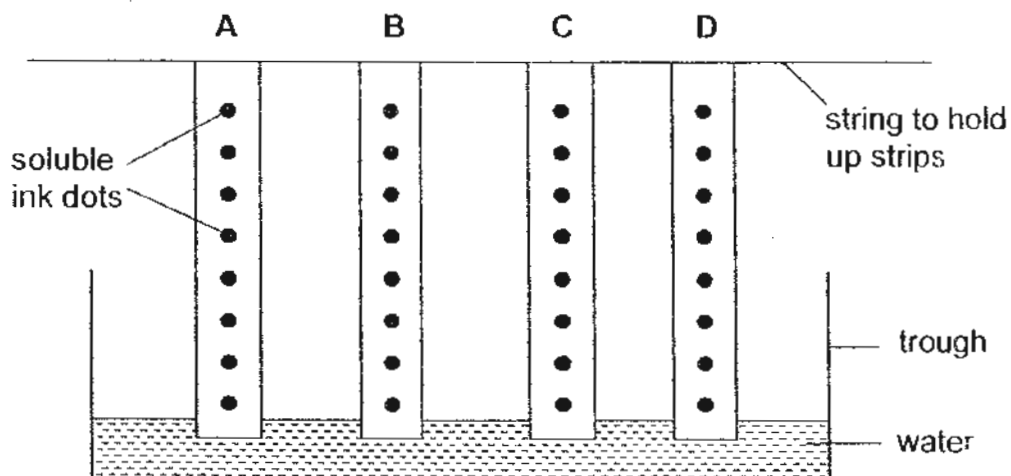

The diagram below shows what was observed after a period of time.

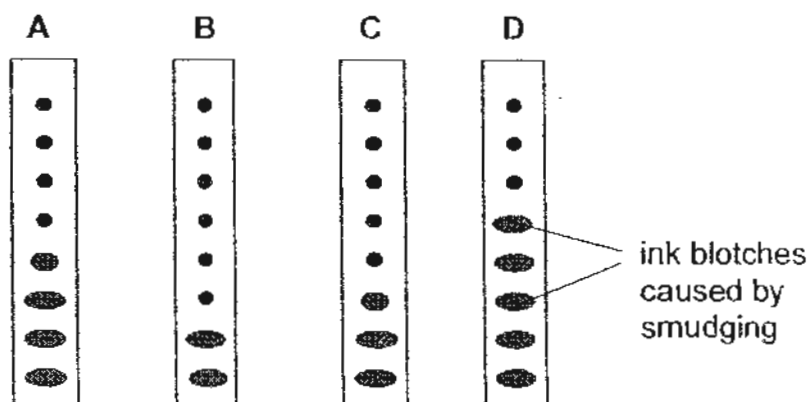

- (a) Based on the observation, which material would be least suitable for making a towel? Explain your answer. [2]

- (b) If the strips were made of metal with ink dots on them, what would be observed of the ink dots after some time? [1/2]

- (c) Give a reason for your answer in (b) above. [1/2]



39. Chung Ling and Sum Yu wanted to find out which material, M or N, is better at retaining heat. They set up the experiments as shown below and wrote down their investigation plans.

Chung Ling and Sum Yu's set-ups

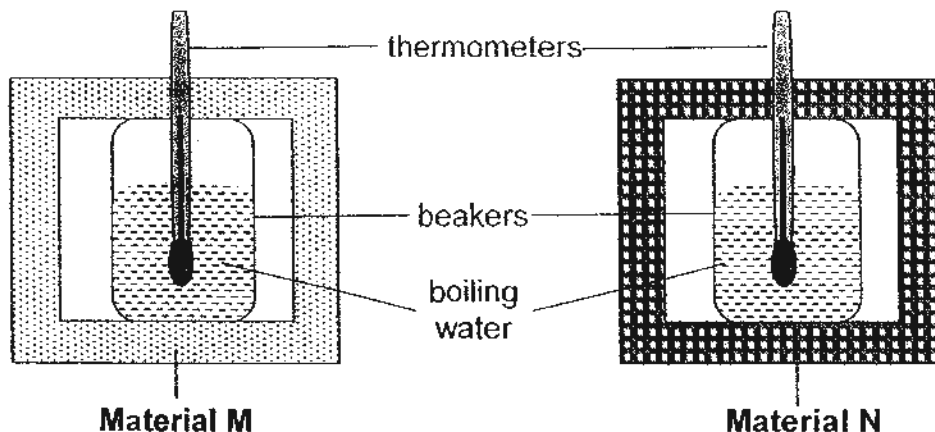

Steps	Chung Ling's Plan
1	Fill 2 similar glass beakers with boiling water.
2	Place one beaker in a box made of material M and the other in a box made of material N.
3	Place a thermometer into each beaker of water.
4	Record the reading on the thermometer by taking out the thermometer every 3 minutes.

Steps	Sum Yu's Plan
1	Fill 2 similar glass beakers with boiling water.
2	Place one beaker in a box made of material M and the other in a box made of material N.
3	Place a thermometer into each beaker of water.
4	Record the reading on the thermometer every 3 minutes without taking out the thermometer.
5	Repeat the experiment 3 times.

- (a) There are some errors in the steps taken in one of the investigation plans. Whose plan is it? [1]

- (b) Suggest 2 reasons to support your answer in (a) above. [2]

40. Mandy wanted to find out the relationship between the number of pebbles in a container and how low this container would sink when it was put in water. She placed different numbers of similar pebbles into five similar containers, V, W, X, Y and Z. The following diagram shows what she observed when the five containers were placed into a huge tank of water.

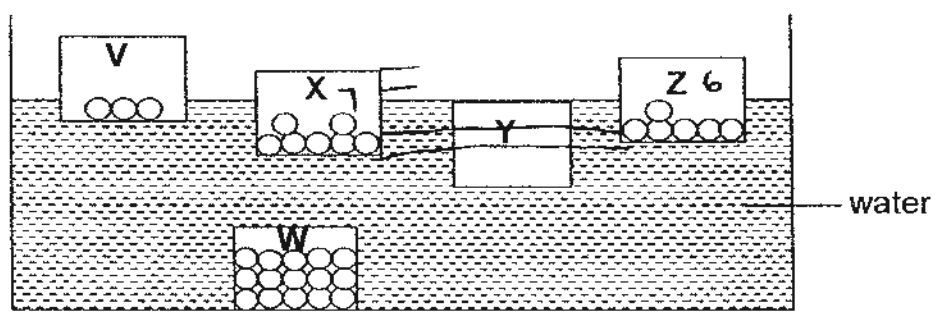

(a) How many pebbles do you think Mandy has placed into container Y? [1]

(b) Based on Mandy's observation, what is the relationship between the number of pebbles in the container and the depth of the container in the water? [1]

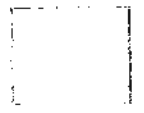

41. Leny carried out an experiment as described below.

She poured some water that was heated to 45°C into a container. She then placed some ice cubes into the container of water.

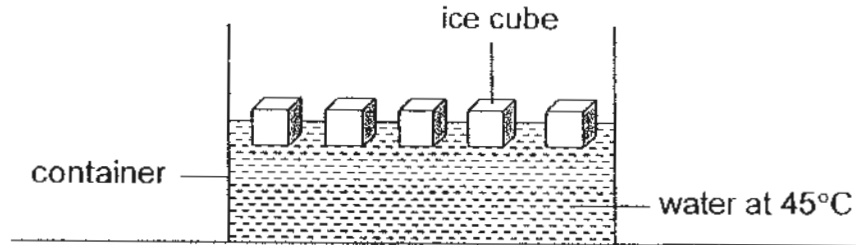

- (a) What would happen to the temperature of the water after Leny had added the ice cubes? Give a reason for your answer. [1]

After all the ice cubes had melted, Leny immersed a metal ball that had been heated to 70°C into the container of water as shown below.

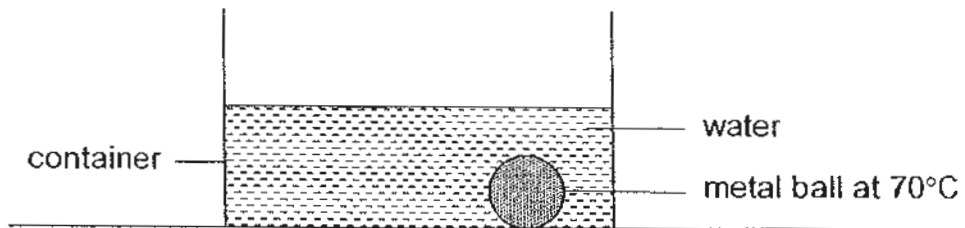

- (b) What would be the final temperature of the metal ball after two hours? [1]

42. The diagram below shows a bicycle dynamo which is used to generate electricity. The friction driver is attached to the wheel of the bicycle which will rotate the driver when it is in motion and produces electricity.

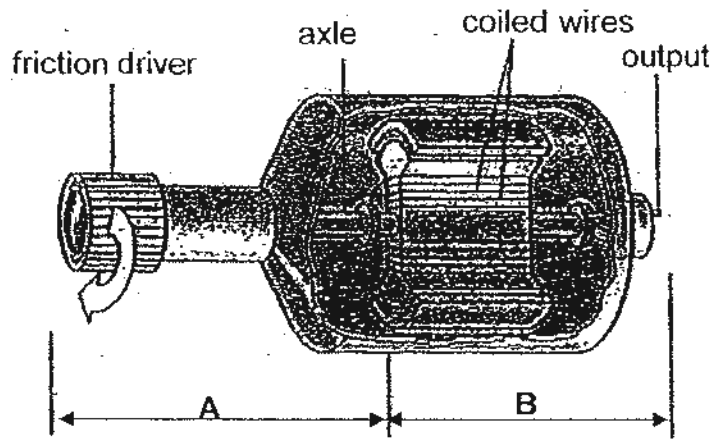

The circuit below is connected to the dynamo above to light up a bulb.

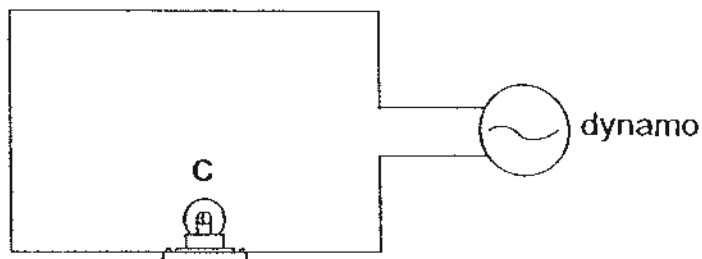

- (a) State the energy conversion from A to C. [2]

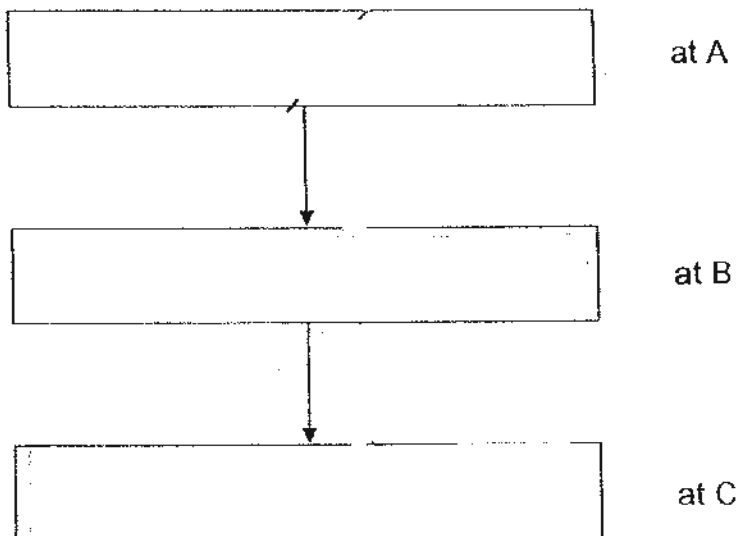

42. (b) When a dynamo is used to generate electricity in a bicycle, an additional power source will be used as a backup to guard against the case of the dynamo failing to work.

Draw a clearly labelled circuit diagram to improve on the above circuit by adding in:

- (i) a battery as a backup energy source, and
- (ii) a switch used to change the power source from the dynamo to the battery in the event that the dynamo fails to work. [1]

Part of the drawing has been done for you.

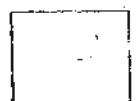
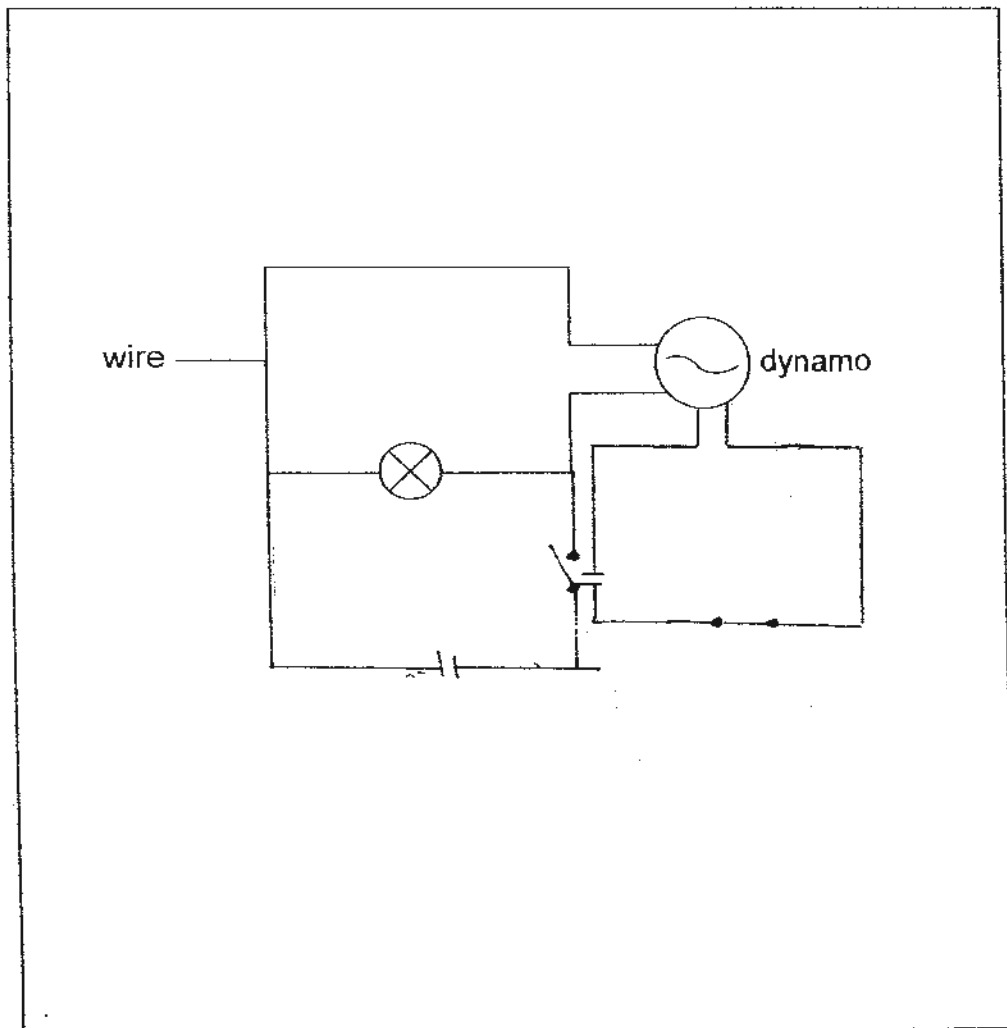

43. Chloe shone a torch on an object from two different positions, as shown in the diagram below. The shadows were cast on two screens, A and B.

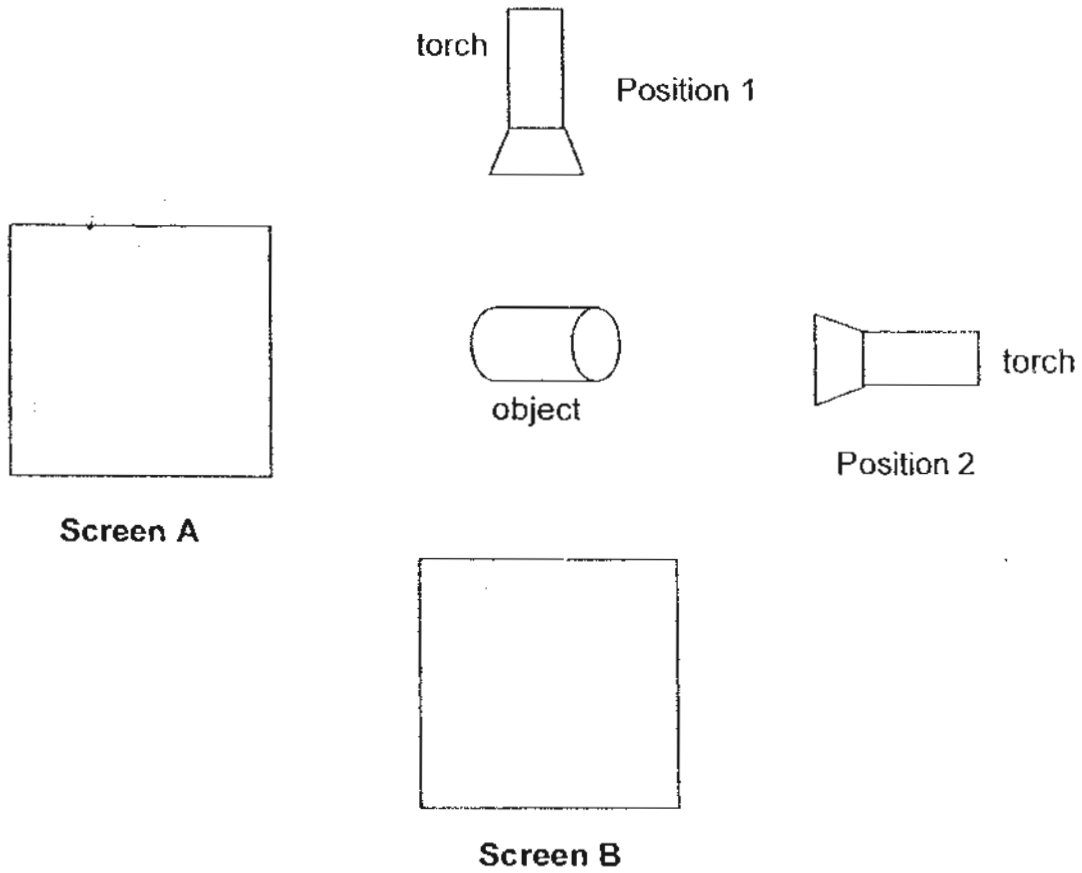

- (a) Draw the shape of the shadows formed on the two screens, A and B, respectively. [2]
-
- (b) Chloe noticed that the shadows formed on both the screens were not sharp. Suggest how Chloe could make the shadows sharper. [1]
-
- (c) What are the properties of light that caused the above shadows to be formed? [1]
-



44. Jayson and his classmates were cycling on a bridge at North Coast Park when they decided to have a competition as they approached a slope. They pedalled as hard as they could from point A to point B (just before the slope) and then they stopped pedalling. They then lifted their feet from the pedals and coasted down the slope before eventually coming to a stop.

A drawing of the path they had taken was shown below.

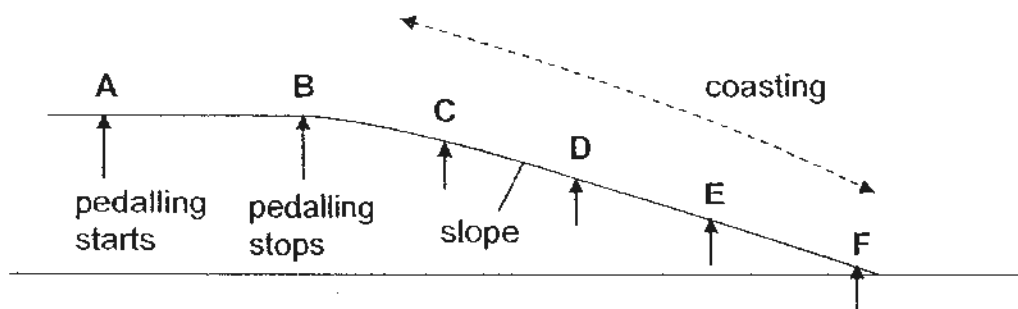

- (a) At which point down the slope (C, D, E or F) did the bicycles travel the fastest? [1]

- (b) What is the energy conversion when Jayson starts to cycle? [1]



- (c) State two other forms of energy that are also present as the bicycles travel from point A to point F. [1]

~~ End of Paper ~~

135



ANSWER SHEET

EXAM PAPER 2010

SCHOOL : CHIJ PRIMARY
SUBJECT : PRIMARY 6 SCIENCE

TERM : PERLIMINARY

Q1	Q2	Q3	Q4	Q5	Q6	Q7	Q8	Q9	Q10	Q11	Q12	Q13	Q14	Q15	Q16	Q17
4	4	4	3	2	1	1	1	2	3	2	2	3	2	3	4	2

Q18	Q19	Q20	Q21	Q22	Q23	Q24	Q25	Q26	Q27	Q28	Q29	Q30
3	4	3	1	4	1	2	3	3	4	3	4	2

31)a)i)It escapes through the stomata as water vapour to cool the plant.
ii)It is to keep the plant firm.
b)The transportation of materials in a plant is in one direction but in a fish, it is in a loop.

32)i)Cell wall.
ii)No. The cell membrane is not removed and it prevents W from entering.

33)a)Mealworms are pests as they fed on the farmer's crops but they are useful as worms can be used as fish food.
b)i)F ii)T iii)T iv)NP

34)i)3pm.
ii)There is insufficient sunlight for the plant to photosynthesize.

35)a)A: Stomach B: Small intestine
b)Similarity: Breaks down food into simpler substances.
Difference: Digestion ends at B but not at A.

36)a)K and C.
b)i)K→D→A→B→F
ii)K→D→A→H→F

37)X, W, Z, Y

38)a) B. It absorbed the least amount of water.

b) The ink will not smudge.

c) Metal cannot absorb water thus water cannot travel upwards to smudge the dots.

39)a) Chung Ling.

b) By taking out the thermometer from the boiling water, the temperature will drop and without repeating the experiment a few times, the result of the experiment are not reliable.

40)a) 9 pebbles.

b) The more the number of pebbles in the container, the deeper the depth of the container in the water.

41)a) The temperature will drop as the water lost heat to the ice cubes.

b) Room temperature.

42)a) Kinetic energy \rightarrow Electrical energy \rightarrow Light + heat energy

b)

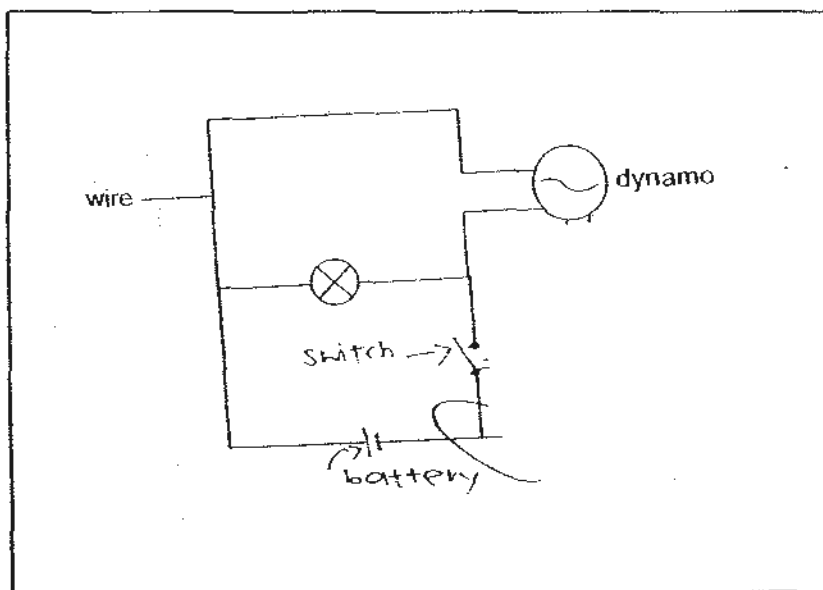

43)a) A: 

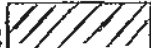
B: 

b) Move the object nearer to the screen.

c) Light travels in a straight line and a shadow is formed when the path of light is blocked by a translucent or opaque object.

44)a) Point F.

b) Chemical potential energy \rightarrow Kinetic energy

c) Gravitation + potential energy and sound energy.

139