



**NAN HUA PRIMARY SCHOOL  
SEMESTRAL ASSESSMENT 1 – 2011  
PRIMARY 4  
MATHEMATICS**

**INSTRUCTION TO CANDIDATES**

1. Write your name and index number in the space provided.
2. Do not turn over the page until you are told to do so.
3. Follow all instructions carefully.
4. Answer all questions.
5. Shade your answers in the Optical Answer Sheet (OAS) provided for Questions 1 - 20.

**Marks Obtained**

Section	Maximum Marks	Actual Marks
A	40	
B	40	
C	20	
Total	100	

Name : \_\_\_\_\_ (      )

Class : Pr 4 \_\_\_\_\_

Date : 11 May 2011

Duration: 1 h 45 min

Parent's Signature : \_\_\_\_\_

**Section A (20 x 2 marks)**

**Questions 1 to 20 carry 2 marks each.**

**For each question, four options are given. One of them is the correct answer. Make your choice (1, 2, 3 or 4). Shade the correct oval on the optical answer sheet (OAS). [40marks]**

1. 3 242 when rounded off to the nearest hundred is \_\_\_\_\_.  
  
( 1 )     3 000  
( 2 )     3 200  
( 3 )     3 240  
( 4 )     3 300
  
2. In which of the following numbers is the digit '6' in the **ten thousands** place?  
  
( 1 )     12 364  
( 2 )     26 134  
( 3 )     34 612  
( 4 )     61 324
  
3. The sum of all the factors of 9 is \_\_\_\_\_.  
  
( 1 )     16  
( 2 )     13  
( 3 )     12  
( 4 )     6
  
4. The first 2 common multiples of 3 and 4 are \_\_\_\_\_.  
  
( 1 )     12 and 24  
( 2 )     10 and 18  
( 3 )     9 and 16  
( 4 )     6 and 8

5. 23 thousands + 9 hundreds + 54 tens = \_\_\_\_\_

(1) 23 990

(2) 23 954

(3) 24 440

(4) 32 540

6. Siti bought a laptop and a television set for \$4 800. The difference between the cost of the two items was \$1 800. If the laptop cost more, how much did the television set cost ?

(1) \$1 200

(2) \$1 500

(3) \$3 000

(4) \$3 300

7. Which of the following fractions below has the **smallest** value ?

(1)  $\frac{1}{2}$

(2)  $\frac{1}{3}$

(3)  $\frac{1}{4}$

(4)  $\frac{3}{8}$

8.  $\frac{11}{12} = \frac{1}{6} + \frac{\boxed{?}}{6} + \frac{1}{12}$

What is the missing number in the box ?

(1) 9

(2) 8

(3) 7

(4) 4

9. How many **sixths** are there in  $1\frac{2}{3}$  ?

- (1) 12
- (2) 10
- (3) 8
- (4) 5

10. David had some marbles. He gave 2 marbles to his brother and had 16 marbles left. What fraction of the total marbles did he give away?

- (1)  $\frac{1}{8}$
- (2)  $\frac{1}{9}$
- (3)  $\frac{7}{8}$
- (4)  $\frac{7}{9}$

11. Which figure shows  $\frac{1}{8}$  shaded ?

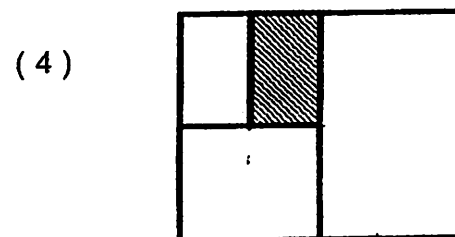
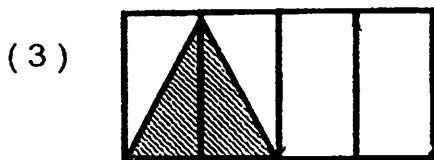
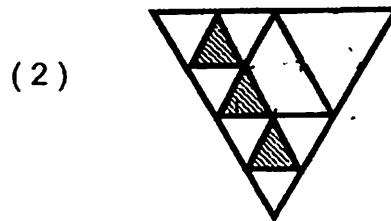
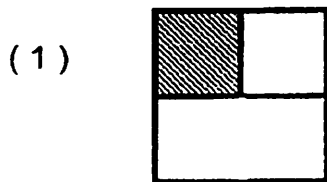

12. The figure below is made up of identical squares.

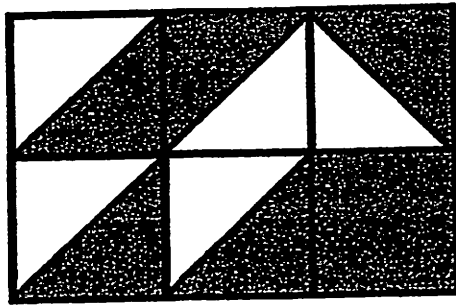

What fraction of the figure is shaded?

(1)  $\frac{5}{12}$

(2)  $\frac{7}{12}$

(3)  $\frac{5}{11}$

(4)  $\frac{1}{3}$

13. How many right angles are there inside the figure below ?

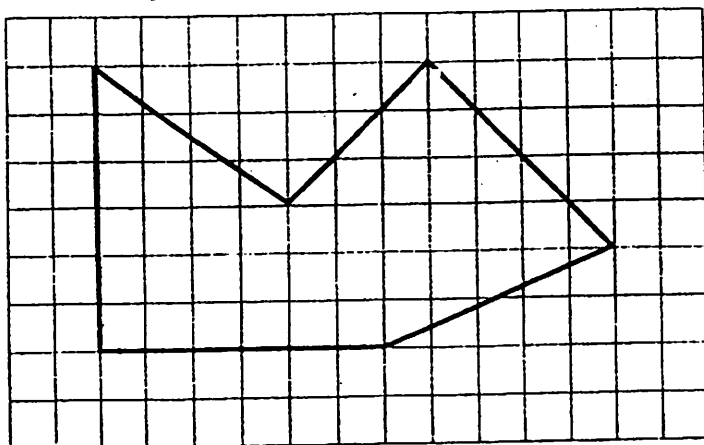

(1) 1

(2) 2

(3) 3

(4) 4

14. How many pairs of parallel lines are there in Figure A?

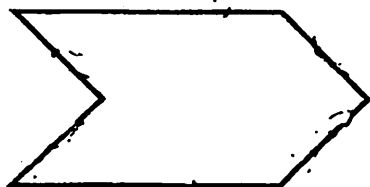
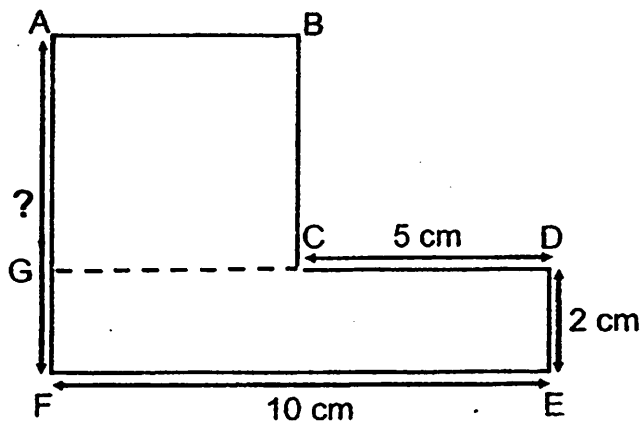

Figure A

- (1) 1
- (2) 2
- (3) 3
- (4) 4

15. The figure below is made up of a square and a rectangle. Find the length of AF. (The diagram is not drawn to scale.)



- (1) 5 cm
- (2) 7 cm
- (3) 8 cm
- (4) 10 cm

16. Square P and Rectangle Q have the same perimeter. What is the length of Rectangle Q ? [The figures are not drawn to scale.]

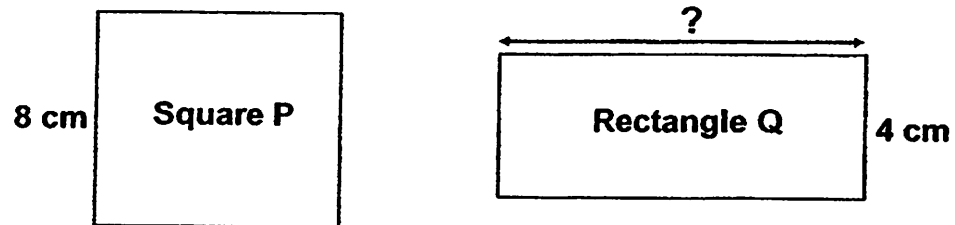

- ( 1 )      32 cm
- ( 2 )      28 cm
- ( 3 )      24 cm
- ( 4 )      12 cm

17. The length of rectangle ABCD is thrice as long as its breadth, what is the area of the rectangle ?

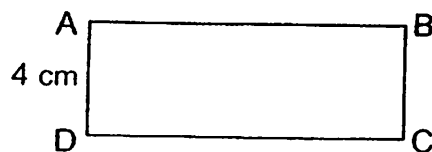

- ( 1 )      48 cm<sup>2</sup>
- ( 2 )      32 cm<sup>2</sup>
- ( 3 )      16 cm<sup>2</sup>
- ( 4 )      12 cm<sup>2</sup>

18. The perimeter of a rectangle is 100 cm. The length of the rectangle is 30 cm. The breadth of the rectangle is \_\_\_\_\_ cm shorter than its length.

- ( 1 )      10 cm
- ( 2 )      20 cm
- ( 3 )      40 cm
- ( 4 )      70 cm

19. The figure below is made up of identical squares. What is the area of the figure?

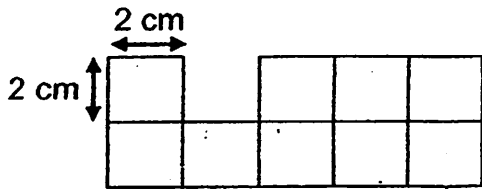

- (1) 36 cm<sup>2</sup>
- (2) 18 cm<sup>2</sup>
- (3) 9 cm<sup>2</sup>
- (4) 4 cm<sup>2</sup>

20. A rectangular field has a length of 10 m and a breadth of 8 m. After a 2 m pavement was built around the field, the area of the field became smaller. What is the area of the field that is not covered by the pavement?

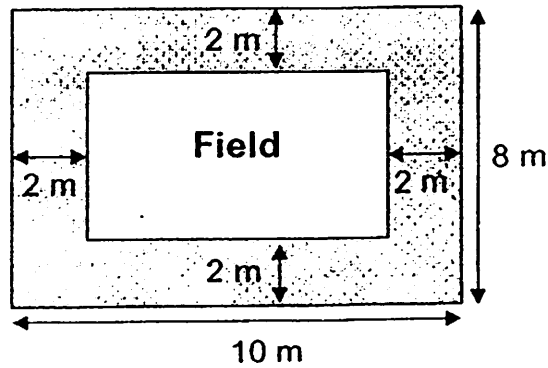

- (1) 16 m<sup>2</sup>
- (2) 24 m<sup>2</sup>
- (3) 64 m<sup>2</sup>
- (4) 80 m<sup>2</sup>

**Section B (20 x 2 marks)**

**Questions 21 to 40 carry 2 marks each. Write your answers in the spaces provided. Show your workings clearly and write the answers in the units provided.**

21. Write 45 890 in words.

22. Divide 5 649 by 7.

Answer: \_\_\_\_\_

23. Form the greatest 4-digit odd number with the digits 5, 2, 3, 8.  
Each digit can be used only once.

Answer: \_\_\_\_\_

24. Express  $2\frac{5}{7}$  as an improper fraction.

Answer: \_\_\_\_\_

25. Max ate  $\frac{3}{10}$  of a cake while his brother ate  $\frac{2}{5}$  of it. What fraction of the cake was uneaten? Leave your answer in its simplest form.

Answer: \_\_\_\_\_

26. If Kate makes  $\frac{3}{4}$  of a complete turn, how many degrees did she make?

Answer: \_\_\_\_\_°

27. Complete the number pattern.

401, 408, 422, \_\_\_\_\_, 471, 506

Answer: \_\_\_\_\_

28. Arrange the following fractions from the smallest to the greatest.

$\frac{2}{3}$ ,  $\frac{1}{6}$ ,  $\frac{7}{12}$

Answer: \_\_\_\_\_, \_\_\_\_\_, \_\_\_\_\_  
smallest

29. There are red and blue ribbons in a box.  $\frac{2}{5}$  of them are blue.  
15 of the ribbons are red. How many **blue** ribbons are there in the box?

Answer: \_\_\_\_\_ blue ribbons

30. Jacintha spent  $\frac{5}{9}$  of her money on a skirt. The price of the skirt was \$35.  
How much did she have at first ?

Answer: \$ \_\_\_\_\_

31. Use a protractor to measure  $\angle p$  in the figure below.  
Then write its value in the blank provided.

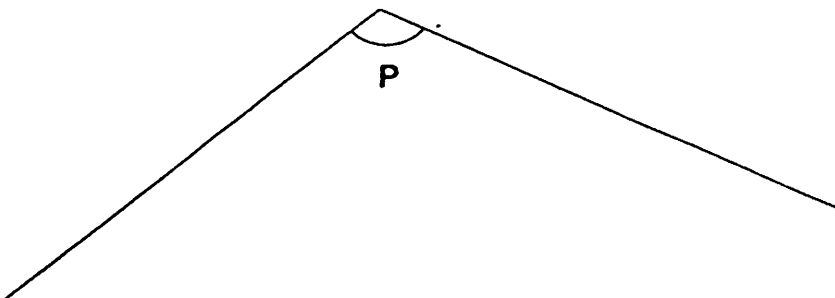

Answer: \_\_\_\_\_

The table below shows the number of T-shirts sold each day for five days. Study it carefully and answer questions 32 to 34.

Monday	☆ ☆ ☆ ☆ ☆
Tuesday	☆ ☆
Wednesday	☆ ☆ ☆ ☆
Thursday	☆ ☆ ☆ ☆ ☆ ☆
Friday	☆ ☆ ☆ ☆ ☆ ☆ ☆
Each ☆ stands for 4 T-shirts.	

32. How many T-shirts were sold on Friday?

Answer: \_\_\_\_\_ T-shirts

33. How many **more** T-shirts were sold on Friday than on Wednesday?

Answer: \_\_\_\_\_ more

34. The number of T-shirts sold on Thursday is \_\_\_\_\_ times as many as the number of T-shirts sold on Tuesday.

Answer: \_\_\_\_\_

35. JK is a straight line. Draw a line perpendicular to the line JK through the point Q.

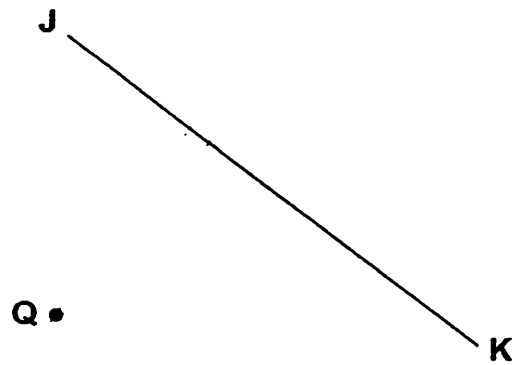

36. NMOP is a rectangle. What is  $\angle s$ ? The figure below is not drawn to scale.

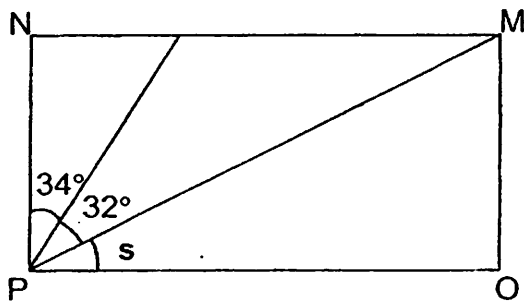

Answer: \_\_\_\_\_

37. Dave used all his money to buy 9 chocolate bars. If he had bought 5 chocolate bars, he would have \$8 left. How much money did Dave have at first?

Answer: \$ \_\_\_\_\_

38. WXYZ is a square. Find the area of the shaded part.

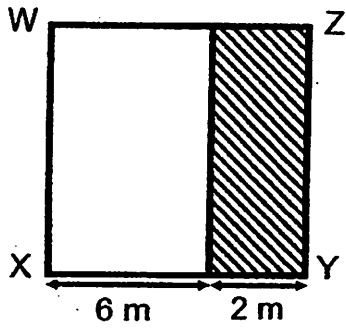

Answer: \_\_\_\_\_ m<sup>2</sup>

39. 24 coins are used to form a square. The number of coins on each side of the square is the same. Find the number of coins on each side of the square.

Answer: \_\_\_\_\_ coins

40. Find the area of the figure below. All lines meet at right angles. (The figure is not drawn to scale.)

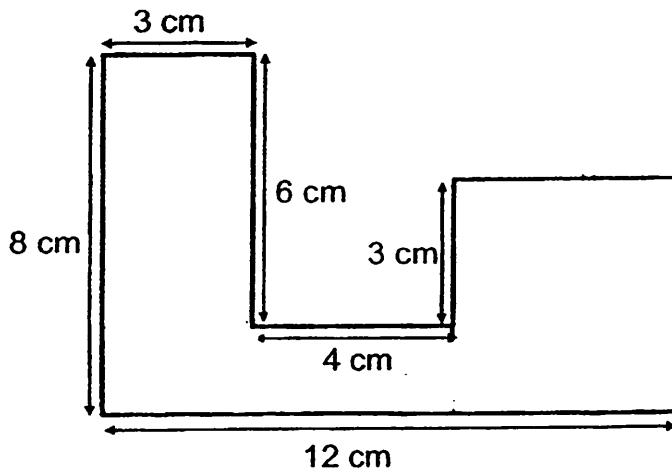

Answer: \_\_\_\_\_ cm<sup>2</sup>

**Section C (20 marks)**

**Do the following sums carefully. All statements, workings and units must be clearly shown.**

41. 42 children were divided into 7 equal groups. Each child got 12 stickers and each group received an extra 10 stickers. How many stickers did they receive altogether ?

42. Jane and Ivan had \$60. After giving Ivan \$8, Jane had the same amount of money as Ivan. How much money did Ivan have at first ?

43. Kelly bought 28 m of cloth. She used  $\frac{4}{7}$  of it to sew a dress. Then, she used another 3 m of cloth to sew a scarf. How many metres of cloth were left?

44. Ali, Ben and Chris have \$620 altogether. Of this total amount, Ali's share is \$90. Ben has \$42 more than Chris. How much money does Ben have ?

45. The figure shown is made up of three rectangles. The figure is not drawn to scale.

- (a) Find the area of the figure.
- (b) Find the perimeter of the figure.

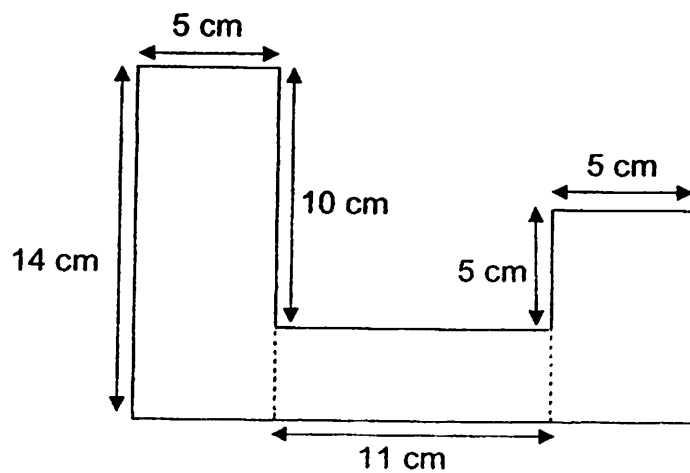

# ANSWER SHEET

## EXAM PAPER 2011

SCHOOL : NAN HUA PRIMARY  
SUBJECT : PRIMARY 4 MATHEMATICS

TERM : SA1

Q1	Q2	Q3	Q4	Q5	Q6	Q7	Q8	Q9	Q10	Q11	Q12	Q13	Q14	Q15	Q16	Q17
2	4	2	1	3	2	3	4	2	2	4	2	2	3	2	4	1

Q18	Q19	Q20
1	1	2

21) Forty-five thousand, eight hundred and ninety

22) 807

23) 8523

24)  $19/7$

25)  $3/10$

26) 270

27) 443

28)  $1/6, 7/12, 2/3$

29) 10

30) \$63

31)  $119^\circ$

32) 28

33) 12

34) 3

35) J

36)  $24^\circ$

37) \$18

38)  $16m^2$

39) 7

40)  $57cm^2$

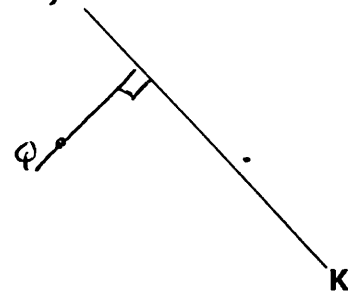

41) 1 group =  $42 \div 7 = 6$  children

1 group stickers  $\rightarrow 12 \times 6 = 72$  stickers

Total  $\rightarrow 72 + 10 = 82$  stickers

7 group  $\rightarrow 82 \times 7 = 574$  stickers

They received 574 stickers.

42)  $\$60 \div 2 = \$30$

$\$30 - \$8 = \$22$

Ivan had \$22 at first.

43)  $4/7 \times 28m = 16m$

$16m + 3m = 19m$

$28m - 19m = 9m$

9m of cloth was left.

44)  $\$620 - \$90 = \$530$

$\$530 - \$42 = \$488$

$\$488 \div 2 = \$244$

$\$244 + \$42 = \$286$

Ben has \$286

45) a) A  $\rightarrow 5cm \times 14cm = 70cm^2$

B  $\rightarrow 4cm \times 11cm = 44cm^2$

C  $\rightarrow 9cm \times 5cm = 45cm^2$

Total  $\rightarrow 45cm^2 + 70cm^2 + 44cm^2 = 159cm^2$

The area of the figure is  $159cm^2$

b) Perimeter  $\rightarrow 5cm + 14cm + 10cm$

$+ 11cm + 21cm + 5cm + 5cm + 9cm$

$= 80cm$

The perimeter of the figure is 80cm