

NANYANG PRIMARY SCHOOL
FIRST SEMESTRAL EXAMINATION
2011

PRIMARY 4
MATHEMATICS

DURATION: 1 HOUR 45 MINUTES

Section A	/ 30
Section B	/ 40
Section C	/ 30

Total:	/ 100
---------------	--------------

Name: _____ ()

Class: Primary 4 ()

Date: 13 May 2011

Parent's Signature: _____

DO NOT OPEN THIS BOOKLET UNTIL YOU ARE TOLD TO DO SO.

FOLLOW ALL INSTRUCTIONS CAREFULLY.

ANSWER ALL QUESTIONS.

5. A number is a multiple of 3 and 5. It is also an even number. What is this number?

(1) 15

(2) 30

(3) 45

(4) 50

6. What is the product of 9803 and 7?

(1) 63 601

(2) 68 600

(3) 68 621

(4) 69 521

7. Lydia and Jen each had the same amount of money. Lydia spent \$600 while Jen spent \$1300. In the end, Lydia had twice as much money as Jen. How much money did Lydia have at first?

(1) \$700

(2) \$1400

(3) \$2000

(4) \$2100

8. Which one of the following is the closest estimate for $5985 \div 8$?

(1) $5900 \div 8$

(2) $5900 \div 10$

(3) $6000 \div 8$

(4) $6000 \div 10$

9. How many fifths are there in $2\frac{3}{5}$?

(1) 10

(2) 11

(3) 12

(4) 13

10. Express $\frac{33}{9}$ as a mixed number in its simplest form.

(1) $3\frac{1}{9}$

(2) $3\frac{2}{3}$

(3) $4\frac{1}{9}$

(4) $4\frac{1}{3}$

11. Mickey bought a blueberry pie. He ate $\frac{5}{7}$ of the pie for lunch and $\frac{1}{7}$ for tea. What fraction of the pie was left?

(1) $\frac{1}{7}$

(2) $\frac{2}{7}$

(3) $\frac{4}{7}$

(4) $\frac{6}{7}$

12. Jen cycled $\frac{1}{3}$ km and Roy cycled $\frac{1}{12}$ km.

Leo cycled $\frac{1}{2}$ km further than the total distance cycled by Jen and Roy.

What was the difference between the distance cycled by Leo and Jen?

(1) $\frac{1}{6}$

(2) $\frac{5}{6}$

(3) $\frac{7}{12}$

(4) $\frac{11}{12}$

15. In the figure shown below, ABCD is a rectangle. Find $\angle ACD$.

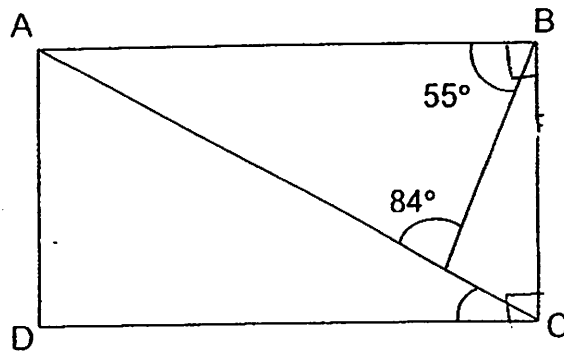

- (1) 35° (2) 41°
(3) 96° (4) 131°

Section B

Questions 16 to 35 carry 2 marks each. Show your working clearly in the space below each question and write your answers in the spaces provided. For questions which require units, give your answers in the units stated.

(Total: 40 marks)

16. In 98 123, the digit 8 stands for

Answer : _____

17. Write the following in numerals.

5 ten thousands, 9 thousands, 40 hundreds and 2 ones

Answer : _____

18. Arrange the following numbers in ascending order.

52 328, 53 200, 52 437, 53 189, 52 278

Answer : _____

19. Factory A can produce 3 896 toy cars in a month. How many toy cars can the factory produce in 6 months? Round off your answer to the nearest 100 toy cars.

Answer : _____

20. What is the product of all the factors of 14?

Answer : _____

21. What is the sum of the first and second common multiples of 6 and 9?

Answer : _____

22. Julian wanted to buy a piano that cost \$7096. He only had \$1000. In order to buy the piano, he had to save for another 8 months. How much would he have to save each month before he could buy the piano? (Assume that he saved equal amount of money each month.)

Answer : \$ _____

23. Find the product of 198 and 29 after rounding off each number to the nearest ten.

Answer : _____

24. Devi used $\frac{4}{5}$ kg of flour to bake a cake and $\frac{7}{15}$ kg of flour to make some bread. How many kilogrammes of flour did she use altogether? Express your answer as a mixed number.

Answer : _____ kg

25. Mr Tan bought an iron rod which was $\frac{1}{6}$ m long and a copper rod which was $\frac{1}{12}$ m longer than the iron rod. What was the total length of the two rods?

Answer : _____ m

26. Tom gave $\frac{1}{4}$ of a chocolate bar to his sister and $\frac{3}{8}$ of the same chocolate bar to his brother. What fraction of the chocolate bar was left?

Answer: _____

27. a) Shade $\frac{2}{3}$ of the happy faces.

- b) What is the total number of happy faces that are not shaded?

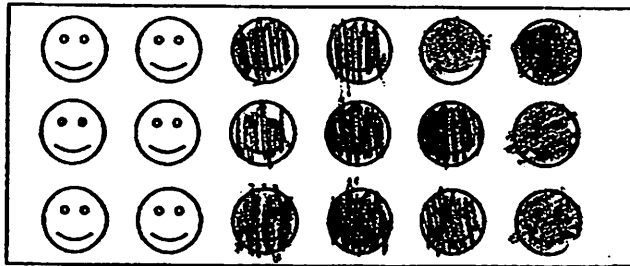

Answer: _____

28. There are 44 red balloons and 55 yellow balloons at a carnival. There are $\frac{3}{4}$ as many green balloons as red balloons. How many balloons are there altogether?

Answer : _____

29. Mrs Dolly bought 64 cupcakes for a party. $\frac{3}{8}$ of the cupcakes were strawberry, $\frac{1}{4}$ were orange cupcakes and the rest were chocolate cupcakes. What was the number of chocolate cupcakes bought by her?

Answer : _____

30. In the figure below, CD, EF, GH and OJ are straight lines. They meet at the centre marked "O".

(a) Name the marked angle in the figure below.

(b) Measure the marked angle.

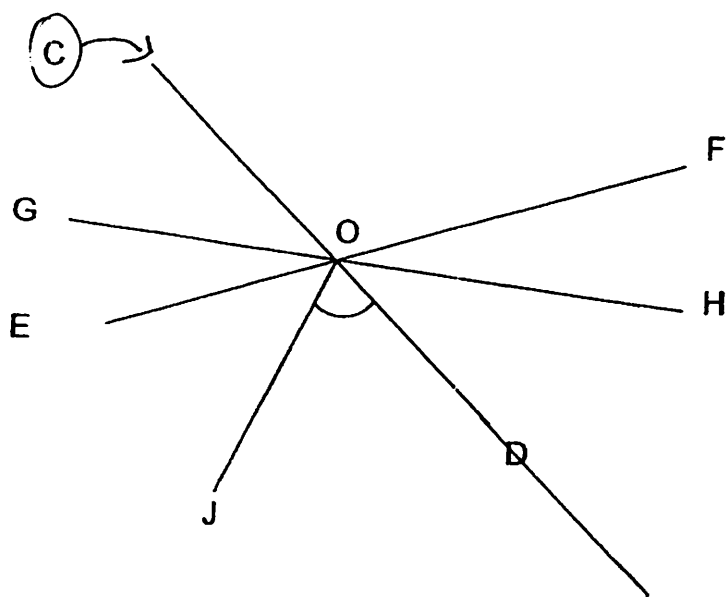

Answer : (a) \angle _____

(b) _____ $^{\circ}$

31. Construct an angle such that $\angle XYZ$ is equal to 130° . Mark and label the angle.

32. The diagram below shows the different locations in Farquhar Primary School.

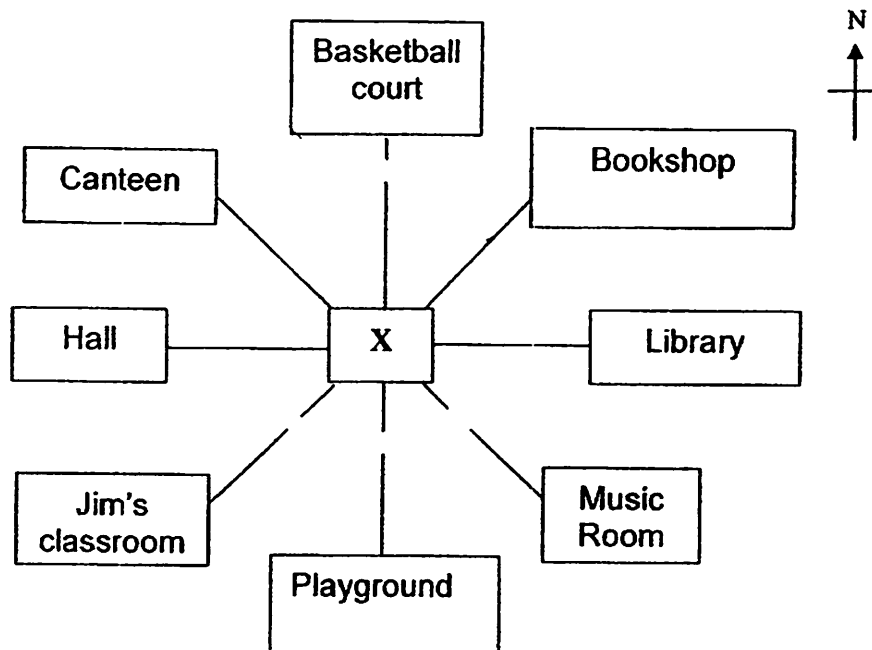

Jim is standing at the spot marked with a X and is facing the canteen.

If he makes a 270° turn clockwise, followed by two $\frac{1}{4}$ turns anti-clockwise, which ^{location} ~~direction~~ will he be facing?

Answer : _____

33. The figure below shows a line AB and a point C. Draw a line parallel to AB passing through point C.

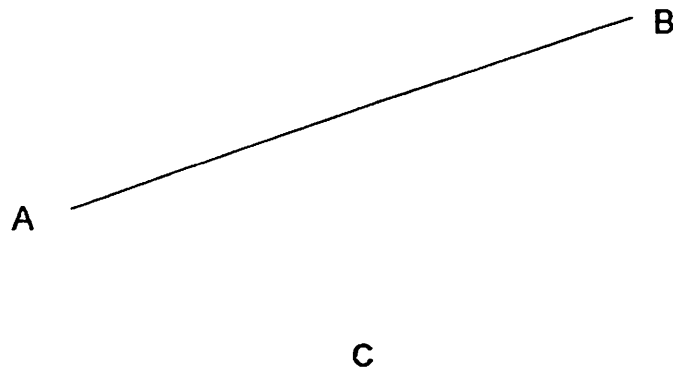

34. The figure below is made up of 5 equal squares Q, R, S, T and U. AB is 7 cm. Find the perimeter of the whole figure. (All the lines meet at right angles.)

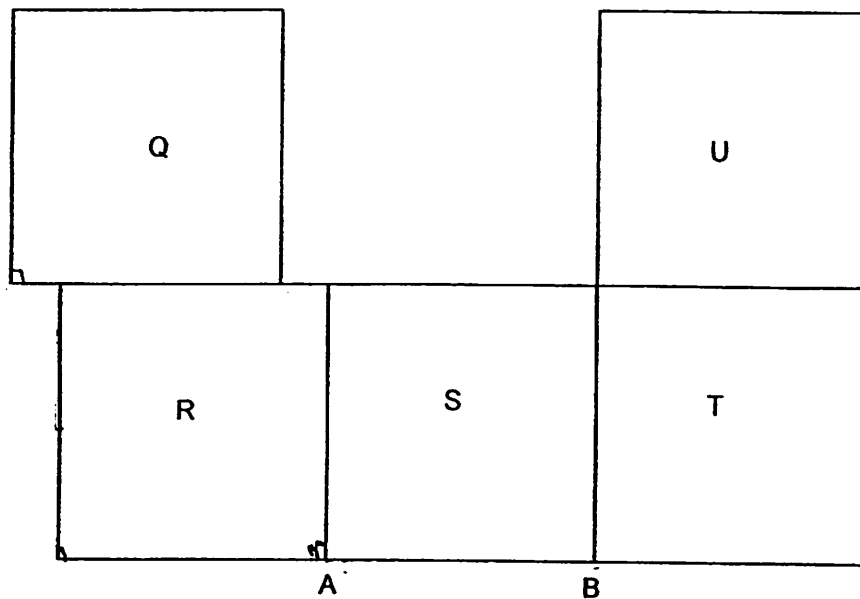

Answer : _____ cm

35. There are 60 ice-cream sticks in a basket. $\frac{1}{6}$ of the ice-cream sticks are blue and $\frac{1}{3}$ of them are yellow. There are twice as many red ice-cream sticks as blue ice-cream sticks. The rest of the ice-cream sticks are purple. How many purple ice-cream sticks are there?

Answer : _____

Section C

Questions 36 to 37 carry 3 marks each and questions 38 to 43 carry 4 marks each. Do these word problems carefully. Show your working clearly in the space provided for each question and write your answers in the spaces provided.

(Total: 30 marks)

36. Sam was given a sum of money. He spent $\frac{1}{11}$ of his money on story books, $\frac{5}{11}$ of his money on game cards and $\frac{2}{11}$ of his money on snacks. He had \$33 left.

- a) What fraction of his money did he spend altogether?
- b) How much money did he spend on snacks?

Ans : a) _____ (1m)

Ans : b) _____ (2m)

37. In the figure below, EFGH is a rectangle and JK is a straight line.

Find

(a) $\angle FJK$

(b) $\angle HJK$

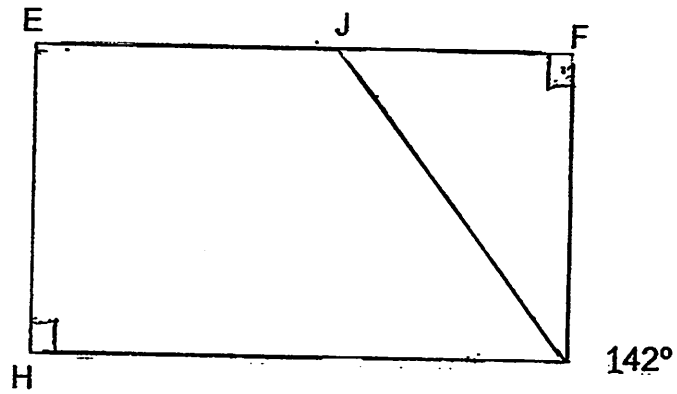

Ans : (a) _____ (2m)

Ans : (b) _____ (1m)

38. Judy has 240 coins with a total value of \$79.50 in her piggy bank. If she has only twenty-cent and fifty-cent coins, how many twenty-cent coins does she have?

Ans : _____ (4m)

39. Mrs Goh baked 1080 brownies a day. She packed them in boxes of 8 and sold them at \$12 per box. At the end of the day, 8 boxes were left. How much money was collected from the sale of the brownies?

Ans : _____ (4m)

40. Angelia wanted to paste her stamps on a piece of rectangular paper measuring 33 cm by 14 cm. All the stamps used are similar in size measuring 4 cm by 3 cm. Assuming that she did not cut any of the stamps, what is the **maximum** number of stamps she can paste on the paper?

Ans: _____ (4m)

41. Max bought candy bars for his provision shop. He packed them into packets of 15 candy bars each. After packing, he found that he had 207 packets and 9 candy bars left.

a) How many candy bars did he buy?

b) How many more candy bars will he need to buy to have 208 packets of candy bars?

Ans: a) _____ (2m)

Ans: b) _____ (2m)

42. Noah had some sweets. He gave 15 sweets to his ^{mother}~~brother~~ while his sister gave him 9 sweets. He then gave twice the number of sweets which his sister had given him to his friend. He had 20 sweets left in the end.

(a) How many sweets did Noah have at first?

(b) If the number of Noah's sweets was four times the number of the sweets his sister had in the beginning, how many sweets did his sister have after giving 9 sweets to Noah?

Ans : (a) _____ (2m)

Ans : (b) _____ (2m)

49

43. Bags X, Y and Z contain 144 apples altogether. Bag X contains 6 ~~more~~^{more} apples than bag Y. The number of apples in bag Z is thrice the total number of apples in bags X and Y. How many more apples are there in bag Z than bag X?

Ans: _____ (4m)

END OF PAPER



Nanyang Primary School
2011 Semestral Assessment 1
Mathematics Paper
Primary 4

Answer Key

Section A

1	(1)	6	(3)	11	(1)
2	(4)	7	(3)	12	(3)
3	(3)	8	(3)	13	(1)
4	(3)	9	(4)	14	(1)
5	(2)	10	(2)	15	(2)

2011 Semestral Assessment 1
Mathematics Paper Section B

- 16) 8000
- 17) 63002
- 18) 52278, 52328, 52437, 53189, 53200
- 19) 23400 toy cars
- 20) 196
- 21) 54
- 22) \$762
- 23) 6000
- 24) $1\frac{4}{15}$ kg
- 25) $\frac{5}{12}$ m
- 26) $\frac{3}{8}$
- 27) 6
- 28) 132
- 29) 24
- 30)(a) Angle JOD (b) 71°
- 32) Bookshop
- 34) 146cm
- 35) 10 purple ice-cream sticks

2011 Semestral Assessment 1

Mathematics Section C

36) (a) Fraction of money spent altogether = $\frac{1}{11} + \frac{5}{11} + \frac{2}{11} = \frac{8}{11}$

(b) Amount he spent on snacks = $11 \times 2 = 22$

Ans: (a) $\frac{8}{11}$
 (b) \$22

37) (a) Angle FGK = 142°

Angle FGJ = $180^\circ - 142^\circ = 38^\circ$

Angle FJK = $180^\circ - 90^\circ - 38^\circ = 52^\circ$

(b) Angle JGH = 52°

Angle HGK = $180^\circ - 52^\circ = 128^\circ$

Ans: (a) 52°
 (b) 128°

38) By trial and error, (see example below)

	No. of 50cents coins	No. of 20cents coins	Total
Value	$120 \times 0.5 = 60$	$120 \times 0.2 = 24$	84
Value	$130 \times 0.5 = 65$	$110 \times 0.2 = 22$	87
Value	$105 \times 0.5 = 52.50$	$135 \times 0.2 = 27$	79.50

Ans: 135 twenty-cent coins

39) Number of boxes packed = $1080 \div 8 = 135$

Number of boxes sold = $135 - 8 = 127$

Amount of money collected from sale = $127 \times 12 = 1524$

Ans: \$1524

40) Maximum number of stamps on 33cm side = $33 \div 3 = 11$

Maximum number of stamps on 14cm side = $14 \div 4 = 3.5 \sim 3$

Maximum number of stamps she can paste = $3 \times 11 = 33$

Ans: 33 stamps

