

METHODIST GIRLS' SCHOOL  
Founded in 1887



PRIMARY 5 MID-YEAR EXAMINATION 2011  
MATHEMATICS  
PAPER 1  
(BOOKLET A)

Total Time for Booklets A and B: 50 minutes

INSTRUCTIONS TO CANDIDATES

Do not turn over this page until you are told to do so.

Follow all instructions carefully.

Answer all questions.

Shade your answers in the Optical Answer Sheet (OAS)  
Provided.

The use of calculators is **NOT** allowed.

Name: \_\_\_\_\_ ( )

Class: Primary 5. \_\_\_\_\_

Date: 5 May 2011

This booklet consists of 6 printed pages including this page.

Questions 1 to 10 carry 1 mark each. Questions 11 to 15 carry 2 marks each.

For each question, four options are given. One of them is the correct answer.

Make your choice (1, 2, 3 or 4). Shade the oval (1, 2, 3 or 4) on the Optical Answer Sheet.

(20 marks)

---

1 The sum of 500 thousands, 60 hundreds and 78 tens when rounded off to the nearest thousand is \_\_\_\_\_.

- (1) 506 000
- (2) 506 600
- (3) 506 780
- (4) 507 000

2 What is the missing number in the box?

$$\frac{3}{5} + \frac{5}{10} + \frac{1}{10} = \boxed{?} \times \frac{1}{10}$$

- (1) 8
- (2) 9
- (3) 10
- (4) 12

3  $\boxed{?} : 16 = 14 : 2$

What is the missing number in the box?

- (1) 112
- (2) 128
- (3) 224
- (4) 256

(Go on to the next page)

- 4 ABCD is a square of side 6 cm. Find the area of the shaded region.

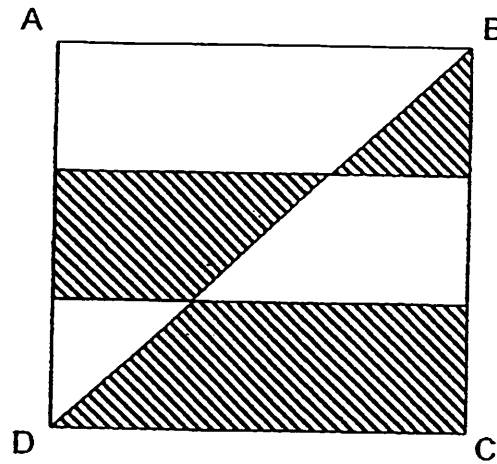

- (1)  $18 \text{ cm}^2$   
(2)  $27 \text{ cm}^2$   
(3)  $36 \text{ cm}^2$   
(4)  $81 \text{ cm}^2$
- 5 Mrs Tan bought a box of oranges. 0.4 of the oranges were rotten. What fraction of the oranges were not rotten?

- (1)  $\frac{2}{5}$   
(2)  $\frac{3}{5}$   
(3)  $\frac{4}{25}$   
(4)  $\frac{6}{25}$

6  $\frac{1}{5}$  of  $\boxed{?}$  is 400 *mℓ*. What is the number in the box?

- (1) 1 ℓ
- (2) 2 ℓ
- (3) 3 ℓ
- (4) 4 ℓ

7  $\frac{1}{4}$  of Shaun's money is  $\frac{1}{3}$  of Jason's money. Express Shaun's money as a fraction of the total amount of money the 2 boys have.

- (1)  $\frac{3}{7}$
- (2)  $\frac{3}{4}$
- (3)  $\frac{4}{7}$
- (4)  $\frac{4}{3}$

8 Which one of the following numbers when rounded off to the nearest thousand is 24 000?

- (1) 23 097 ✗
- (2) 23 499 ✗
- (3) 24 400 ✓
- (4) 24 501 ✗

(Go on to the next page)

- 9 What number is 0.001 less than 6?
- (1) 5.99
  - (2) 5.999
  - (3) 6.001
  - (4) 6.009
- 10 Mina weighs 48 kg. Kenneth's weight is  $\frac{5}{6}$  of Mina's weight and Jonathan's weight is  $\frac{4}{5}$  of Kenneth's weight. What is Jonathan's weight?
- (1) 28 kg
  - (2) 32 kg
  - (3) 35 kg
  - (4) 40 kg
- 11 What is the maximum number of 20-cm long strings that can be cut from a string that is  $2\frac{3}{4}$  metres long?
- (1) 10
  - (2) 11
  - (3) 12
  - (4) 13
- 12 How many tenths are there in 30.3?
- (1) 303
  - (2) 33
  - (3) 3
  - (4) 30

(Go on to the next page)

- 13 3 chairs and 2 tables cost \$875. A table costs \$220 more than a chair.  
What is the cost of a chair?
- (1) \$43  
(2) \$87  
(3) \$175  
(4) \$261
- 14 The ratio of the price of a pencil to that of a pen is 1: 3. The pen costs \$1.05. A teacher buys 8 pencils and 5 pens. How much does she have to pay for the stationery?
- (1) \$8.05  
(2) \$10.15  
(3) \$13.65  
(4) \$24.15
- 15 Mrs Wang bought 20 kg of rice at \$ 1.80 per kg. If each kg of rice were to cost 30 cents less, how much more rice could she buy with the same amount of money?
- (1) 30 kg  
(2) 24 kg  
(3) 6 kg  
(4) 4 kg

METHODIST GIRLS' SCHOOL  
Founded in 1887



PRIMARY 5 MID-YEAR EXAMINATION 2011  
MATHEMATICS

PAPER 1  
(BOOKLET B)

Total Time for Booklets A and B: 50 minutes

INSTRUCTIONS TO CANDIDATES

Do not turn over this page until you are told to do so.

Follow all instructions carefully.

Answer all questions.

Write your answers in this booklet.

The use of calculators is **NOT** allowed.

Name: \_\_\_\_\_ ( . )

Class: Primary 5. \_\_\_\_\_

Date: 5 May 2011

<b>Paper 1 Booklet A</b>	<b>/ 20</b>
<b>Paper 1 Booklet B</b>	<b>/ 20</b>
<b>Paper 2</b>	<b>/ 60</b>
<b>TOTAL</b>	<b>/ 100</b>

This booklet consists of 7 printed pages including this page.

Questions 16 to 25 carry 1 mark each. Write your answers in the space provided.  
For questions which require units, give your answers in the units stated

(10 marks)

16 In 5 975 864, the value of the digit "7" is  $7 \times$  \_\_\_\_\_.

Ans: \_\_\_\_\_

17 Find the value of  $\frac{4}{5} \div 16$ .

Express your answer as a fraction in its simplest form.

Ans: \_\_\_\_\_

18 In the figure below, how many more triangles must be shaded so that the ratio of the number of shaded triangles to the total number of triangles is 2 : 3?

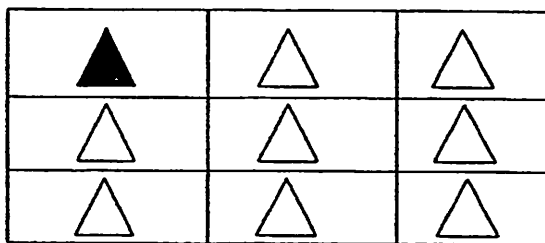

Ans: \_\_\_\_\_

(Go on to the next page)

- 19 Express 20.05 km in kilometres and metres.

Ans: \_\_\_\_\_ km \_\_\_\_\_ m

- 20 Kathy has a total of 72 blue and yellow beads. The number of blue beads is  $\frac{3}{5}$  the number of yellow beads. How many yellow beads does she have?

Ans: \_\_\_\_\_

- 21 A book has 50 pages numbered from page 1 to page 50. On how many pages will the sum of the digits add up to 10?

Ans: \_\_\_\_\_

(Go on to the next page)

- 22 Find the area of the shaded part of rectangle ABCD.

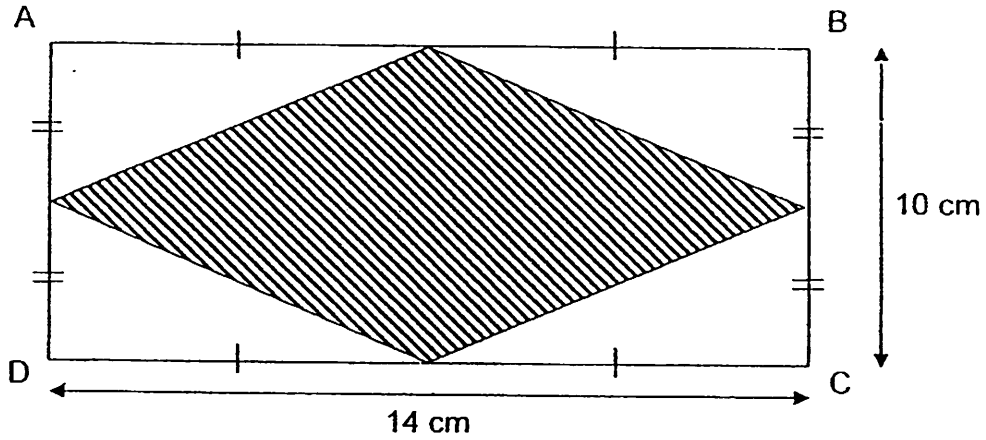

Ans: \_\_\_\_\_  $m^2$

- 23 At a sports carnival,  $\frac{1}{4}$  of the participants played badminton,  $\frac{3}{5}$  of the participants played volleyball and the rest of the participants played hockey. Which one of the following pie charts below best represents the information given?

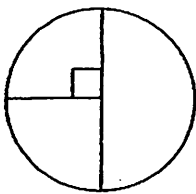

Pie Chart A

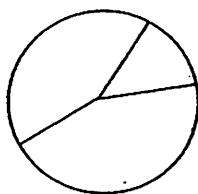

Pie Chart B

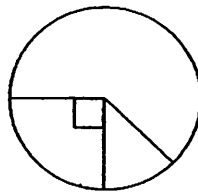

Pie Chart C

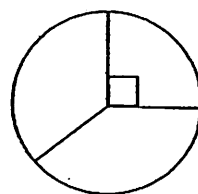

Pie Chart D

Ans: \_\_\_\_\_

(Go on to the next page)  $\overline{\text{71}}$

- 24 Ali, Bob and Candy have a total of \$134.50. Ali has \$8 more than Bob. Candy has thrice as much money as Ali. How much money does Bob have?

Ans: \$ \_\_\_\_\_

- 25 Beaker A contains 0.75  $\ell$  of water and Beaker B contains 300  $m\ell$  of water. How much water must be poured from Beaker A to Beaker B so that there is an equal amount of water in each container?

Ans: \_\_\_\_\_  $m\ell$

(Go on to the next page)

Questions 26 to 30 carry 2 marks each. Show your working clearly in the space below each question and write your answers in the spaces provided. For questions which require units, give your answers in the units stated.

(10 marks)

26 A 5-digit number when rounded off to the nearest ten thousand is 70 000.

- a) What is the smallest possible number?
- b) What is the largest possible number?

Ans: (a) \_\_\_\_\_

(b) \_\_\_\_\_

27  $\frac{4}{9}$  of the number of blue pens in a box is equal to  $\frac{1}{5}$  of the number of red pens.

There are 609 blue and red pens in the box. How many more red pens than blue pens are there in the box?

Ans: \_\_\_\_\_

28 A shopkeeper bought 7 sacks of flour, each of mass 14 kg. He used up all the flour in 5 days. If he used the same amount of flour each day, how many kilograms of flour did he use each day?

Ans: \_\_\_\_\_ kg

(Go on to the next page)

- 29 Mr Tan bought 1.4 kg of grapes, 0.875 kg of cherries and a watermelon with a mass of 2kg 45 g. What is the total mass of the fruit he bought? Express your answer as a decimal.

Ans: \_\_\_\_\_ kg

- 30 The perimeter of the rectangle below is 126 cm. Its breadth is  $\frac{3}{4}$  of its length. Find the area of the shaded triangle.

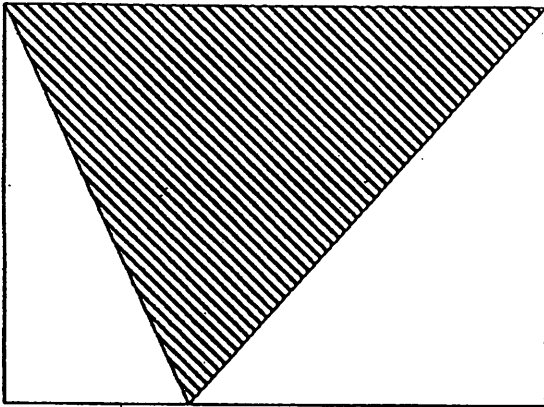

Ans: \_\_\_\_\_ cm<sup>2</sup>

# METHODIST GIRLS' SCHOOL

Founded in 1887



## PRIMARY 5 MID-YEAR EXAMINATION 2011 MATHEMATICS

### PAPER 2

Total Time: 1 h 40 min

#### INSTRUCTIONS TO CANDIDATES

Do not turn over this page until you are told to do so.

Follow all instructions carefully.

Answer all questions.

Write your answers in this booklet.

The use of an approved calculator is expected, where appropriate.

Name: \_\_\_\_\_ ( )

Class: Primary 5. \_\_\_\_\_

Date: 5 May 2011

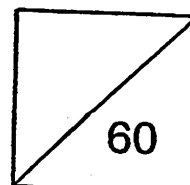

This booklet consists of 13 printed pages including this page.

Questions 1 to 5 carry 2 marks each. Show your working clearly in the space provided for each question and write your answers in the spaces provided. For questions which require units, give your answers in the units stated. (10 marks)

---

- 1 The sum of 2 numbers is 146. If  $\frac{3}{4}$  of the larger number is 75, what is the product of the 2 numbers?

Ans: \_\_\_\_\_

- 2 Jane needed 0.8 kg of sugar to bake 4 muffins. She had 200 g of sugar. How many more kilograms of sugar did she have to buy to bake 12 muffins?

Ans: \_\_\_\_\_ kg \_\_\_\_\_ g

- 3 The product of 2 numbers is 160.  
One of the numbers is 10 times the other number.  
What are the two numbers?

Ans: \_\_\_\_\_ and \_\_\_\_\_

(Go on to the next page)

- 4 The figure below is not drawn to scale.  
Find the area of the shaded triangle ABC.

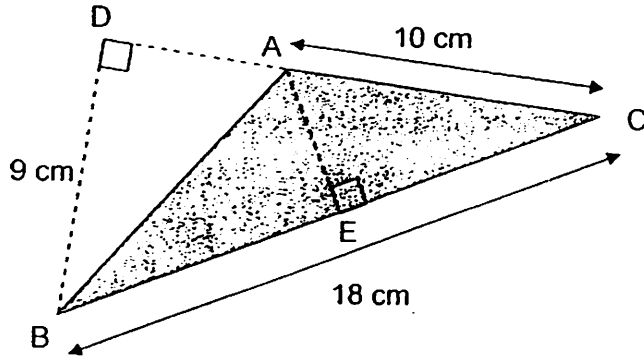

Ans: \_\_\_\_\_ cm<sup>2</sup>

- 5 Find the value of P.

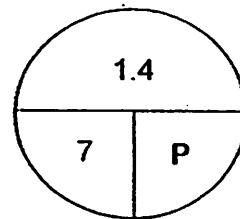
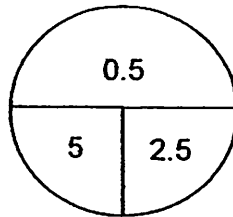
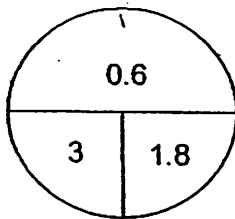

Ans: \_\_\_\_\_

(Go on to the next page)

For questions 6 to 18, show your working clearly in the space provided for each question and write your answers in the spaces provided.

The number of marks available is shown in brackets [ ] at the end of each question or part-question. (50 marks)

6 Mr Tan has some pineapples for sale.

He sold  $\frac{1}{3}$  of the pineapples in the morning and  $\frac{2}{5}$  of the remainder in the afternoon.

If he sells 80 pineapples in the afternoon, how many pineapples did he sell in the morning?

Ans: \_\_\_\_\_ [3]

7 Find the value represented by A, B and C.

1	B	C	3
X			4
A	6	B	C

Ans: A = \_\_\_\_\_ [1]

B = \_\_\_\_\_ [1]

C = \_\_\_\_\_ [1]

(Go on to the next page)

- 8 Mrs Soh uses 1.85 m of ribbon to make a flower.  
She wants to make 5 similar flowers for her friends.  
Each metre of ribbon costs \$0.85.

- (a) How many metres of ribbon does she need?
- (b) How much does she have to pay for the ribbon altogether?  
Express your answer to the nearest dollars.

Ans: (a) \_\_\_\_\_ [2]

(b) \_\_\_\_\_ [2]

(Go on to the next page)

- 9 At a party, some balloons were used to decorate the room.  
At 1 p.m., 13 less than half the number of balloons was given out.  
At 3 p.m., another half of the remainder plus 8 balloons were given out and there was 20 balloons left.  
How many balloons were there at the beginning of the party?

Ans: \_\_\_\_\_ [5]

(Go on to the next page)

- 10 The length of the sides of a triangle are in the ratio 3 : 4 : 5.  
The length of the shortest side of the triangle is 15 cm.  
What is the perimeter of the triangle?

Ans: \_\_\_\_\_ [3]

- 11  $\frac{4}{5}$  of the seats in a airplane were economy seats. The rest were business class seats.  
 $\frac{1}{3}$  of the business class seats were unoccupied. What fraction of all the seats were occupied business class seats?

Ans: \_\_\_\_\_ [3]

(Go on to the next page)

- 12  $\frac{3}{5}$  of apples is the same as  $\frac{4}{9}$  of oranges.  
Find the ratio of the number of apples to the number of oranges.

Ans: \_\_\_\_\_ [3]

- 13 In the school library, the ratio of fiction books to non-fiction books is 8 : 13.  
After 126 non-fiction were lost, the new ratio is 4 : 5.  
How many fiction books were there at first?

Ans: \_\_\_\_\_ [4]

(Go on to the next page)

- 14 Mrs Lim distributed 300 souvenirs from the Art Museum to some girls in Primary Four and Primary Five.  
Each Primary Four girl received 5 souvenirs and each Primary Five girl received 3 souvenirs.  
The Primary Four girls received 60 more souvenirs than those in Primary Five.  
How many more Primary Five girls were there?

Ans: \_\_\_\_\_ [5]

(Go on to the next page)

- 15 Mrs Chan paid \$2 056 for some printers and some cameras.  
She bought one more camera than printers.  
A printer costs \$257.  
A camera cost twice as much.

(a) How many cameras did she buy?

printers?

(b) How much more did she spend on the cameras than on the ~~printer?~~

Ans: (a) \_\_\_\_\_ [2]

(b) \_\_\_\_\_ [2]

(Go on to the next page)

16 At a party,  $\frac{2}{3}$  are girls and the rest are boys.

After 5 girls and 5 boys left the party, the number of boys left is  $\frac{1}{3}$  the number of girls.

(a) How many pupils are there at the party in the end?

(b) Express the number of pupils who left the party as a fraction of the total number of pupils

Ans: (a) \_\_\_\_\_ [2]

(b) \_\_\_\_\_ [2]

(Go on to the next page)

- 17 Flower pots are to be placed along the road at regular intervals. The distance between two flower pots is 12 m.
- How long is the road if a total of 18 flower pots, including both ends, are to be placed on the road?
  - If the road is 240 m, how many more flower pots are needed to be placed along the road?

Ans \_\_\_\_\_

Ans \_\_\_\_\_

(Go on to the next page)

- 18 The figure below, not drawn to scale, is made up of two identical squares, X and Z and a rectangle Y.  
 The ratio of the area X to the area of Y to the area of Z is  $1 : 2 : 1$ .  
 The ratio of the unshaded part of X to the unshaded part Y to the unshaded part of Z is  $2 : 5 : 3$  respectively.  
 Given that half of the area of X is shaded and the total area of all the shaded parts is  $48 \text{ m}^2$ , what is the area of the whole figure?

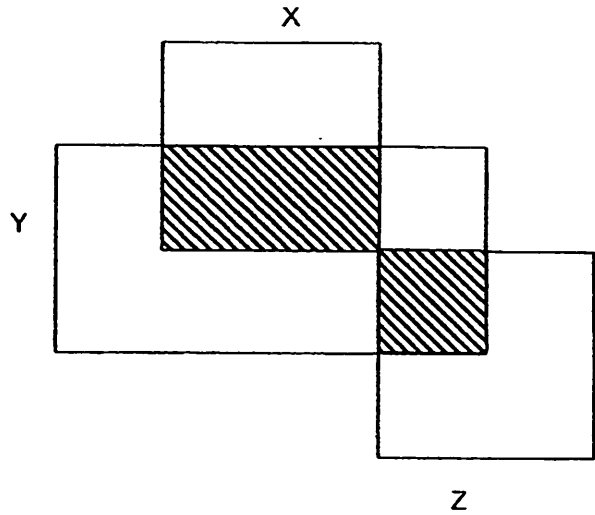

Ans: \_\_\_\_\_ [5]

# ANSWER SHEET

**EXAM PAPER 2011**

**SCHOOL : MGS PRIMARY  
SUBJECT : PRIMARY 5 MATHEMATICS**

**TERM : SA1**

Q1	Q2	Q3	Q4	Q5	Q6	Q7	Q8	Q9	Q10	Q11	Q12	Q13	Q14	Q15
4	4	1	1	2	2	3	3	2	2	4	2	1	1	2

16)10000

17)1/20

18)5

19)20km 50m

20)45

21)10

22)70cm<sup>2</sup>

23)Pie chart C

24)\$20.50

25)225ml

26)a)65000  
b)74999

27)231

28)19.6kg

29)4.32kg

30)486cm<sup>2</sup>

## paper 2

1)  $75 \div 3 = 25$

$25 \times 4 = 100$  (big no.)

$146 - 100 = 46$  (small no.)

$100 \times 46 = 4600$

The product is 4600.

2)  $0.8\text{kg} = 800\text{g}$

$12 \div 4 = 3$

$800 \times 3 = 2400(\text{g})$

$2400 - 200 = 2200(\text{g})$

$2200\text{g} = 2.200\text{kg}$

$= 2\text{kg } 200\text{g}$

She needs 2kg 200g more.

3)40 and 4

4)  $\frac{1}{2} \times 9 \times 10 = 45$

The area is 45cm<sup>2</sup>

5)  $1.8 \div 3 = 0.6$

$0.6 \times 3 = 1.8$

$1.4 \times 7 = 9.8$

The value of P is 9.8

6)  $\frac{2}{3} \times \frac{2}{5} = \frac{4}{15}$

$\frac{2}{3} \times \frac{3}{5} = \frac{6}{15}$

$4u \rightarrow 80$

$1u \rightarrow 80 \div 4 = 20$

$5u \rightarrow 20 \times 5 = 100$

He sold 100 pineapples in the morning.

7)A)7

B)9

C)2

8)a)  $1.85 \times 5 = 9.25$

She needs 9.25m of ribbon

b)  $9.25 \times 0.85 = 7.8625(\$)$   $\approx$  \$8

She have to pay \$8

9)  $20 + 8 = 28$

$28 \times 2 = 56$

$56 - 13 = 43$

$43 \times 2 = 86$  balloons

10)  $3u \rightarrow 15$

$1u \rightarrow 15 \div 3 = 5$

$5 + 4 + 3 = 12$

$12u \rightarrow 5 \times 12 = 60$

The perimeter is 60cm

11)  $1/5 \times 2/3 = 2/15$

The fraction is  $2/15$

12) 20:27

13)  $13 - 10 = 3$

$3u \rightarrow 126$

$1u \rightarrow 126 \div 3 = 42$

$8u \rightarrow 42 \times 8 = 336$

There were 336 at first.

14) 4 more

15) a) 3

b) \$1028

16) a) 20 pupils

b)  $1/3$

17) a) 204m

b) 3

18)  $48 \div 3 = 16$

$16 \times 3 = 208m^2$