



**RAFFLES GIRLS' PRIMARY SCHOOL
SEMESTRAL ASSESSMENT 1
MATHEMATICS (PAPER 1)
PRIMARY 5**

Name: _____ ()

Form Class: P5 _____ Banded Math Class: P5 _____

Date: 10 May 2011

Duration: 50 min

Your Score (Out of 100 marks)			
Your Score (Out of 40 marks)			
		Banded Math Class	Level
PAPER 1 (40%)	Highest Score		
	Average Score		
TOTAL (100%)	Highest		
	Average Score		
Parent's Signature			

INSTRUCTIONS TO CANDIDATES

1. Do not turn over this page until you are told to do so.
2. Follow all instructions carefully.
3. Answer **ALL** questions and show all working clearly.
4. **NO** calculator is allowed for this paper.

SECTION A (20 marks)

Questions 1 to 10 carry 1 mark each. Question 11 to 15 carry 2 marks each. For each question, four options are given. One of them is the correct answer. Make your choice (1, 2, 3 or 4). Shade your answer (1, 2, 3 or 4) on the OAS provided. All diagrams are not drawn to scale.

1. How many ten-dollar notes make up \$201 010?

(1) 10

(2) 20

(3) 2 010

(4) 20 101

() ()

2. What is the product of 83×700 ?

(1) 581

(2) 5 810

(3) 58 100

(4) 581 000

() ()

3. Find the volume of the cuboid shown below.

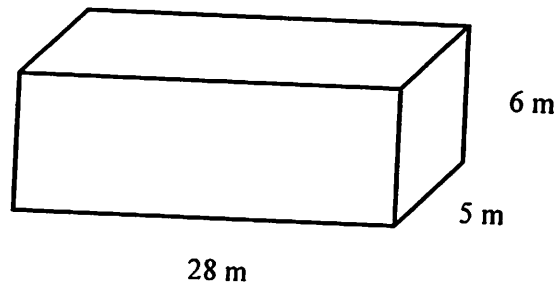

- (1) 84 m^3
- (2) 140 m^3
- (3) 168 m^3
- (4) 840 m^3

()

4. What is the missing number in the box?

$$3\frac{\square}{9} = 4\frac{2}{3}$$

- (1) 6
- (2) 8
- (3) 14
- (4) 15

()

5. Express $\frac{38}{4}$ as a mixed number.

- (1) $3\frac{8}{4}$
- (2) $8\frac{3}{4}$
- (3) $9\frac{1}{4}$
- (4) $9\frac{1}{2}$

()

6. Which of the following figures cannot be tessellated?

(1)



(2)



(3)



(4)

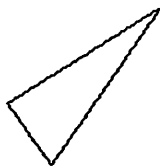

()

7. In 43.21, which digit is in the tenths place?

(1) 1

(2) 2

(3) 3

(4) 4

()

8. Express 0.025 as a fraction in its lowest term.
The answer is _____.

(1) $\frac{1}{4}$

(2) $\frac{1}{8}$

(3) $\frac{1}{25}$

(4) $\frac{1}{40}$

()

9. Which of the following is a common factor of 6 and 27?

(1) 27

(2) 2

(3) 3

(4) 54

()

10. Which one of the following when rounded off to the nearest thousand gives 190 000?

(1) 185 809

(2) 189 099

(3) 189 599

(4) 191 099

()

11. What is the area of the shaded triangle?

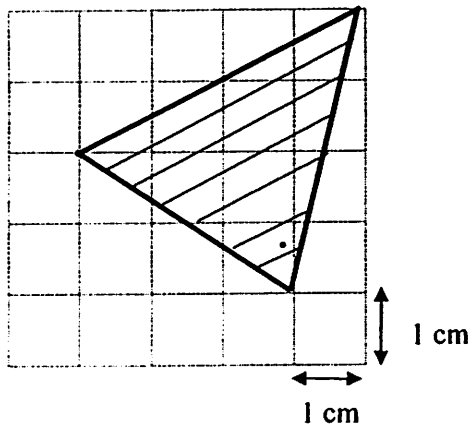

(1) 6 cm^2

(2) 7 cm^2

(3) 8 cm^2

(4) 9 cm^2

()

12. Which of the following figure(s) has/have the line of symmetry drawn correctly?

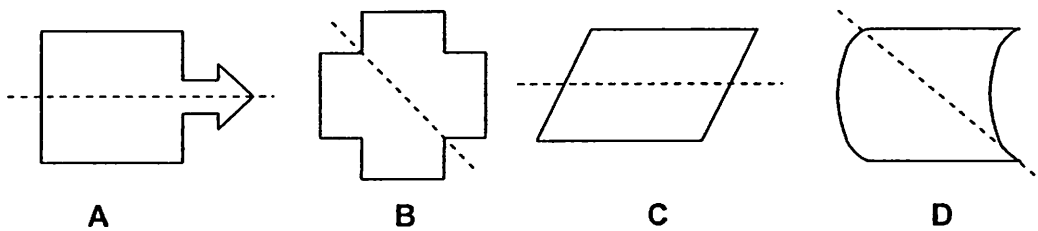

(1) A and B only

(2) B and D only

(3) C and D only

(4) A, B and C only

()

13. $\frac{1}{8}$ of Mary's money is equal to $\frac{7}{32}$ of Peter's money.
Find the ratio of Mary's money to Peter's money.

- (1) 1 : 7
- (2) 1 : 4
- (3) 4 : 7
- (4) 7 : 4

()

14. The solid below is made up of identical cubes. The total area of the shaded faces is 108 cm^2 . Find the volume of the solid.

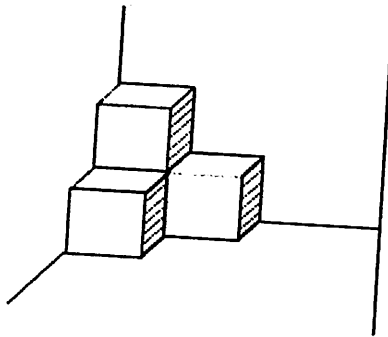

- (1) 36 cm^3
- (2) 216 cm^3
- (3) 864 cm^3
- (4) 972 cm^3

()

15. Sally spent $\frac{3}{7}$ of her money on books and \$58 on shoes.
If she had \$27 left, how much did the books cost?

- (1) \$14.50
- (2) \$21.25
- (3) \$43.50
- (4) \$63.75

()

Questions 16 to 25 carry 1 mark each. Write your answers in the spaces provided. For questions which require units, give your answers in the units stated. All diagrams are not drawn to scale. Answers in fractions or ratio must be expressed in the simplest form.

16. Arrange the numbers in descending order.

513 082, 231 058, 213 058, 513 820

Ans: _____, _____, _____, _____

17. Fill in the blank.

$$28.13 = 28 + \underline{\quad ? \quad} + 0.03$$

Ans: _____

18. Find the maximum number of 2-cm cubes that can be cut from the rectangular block given below.

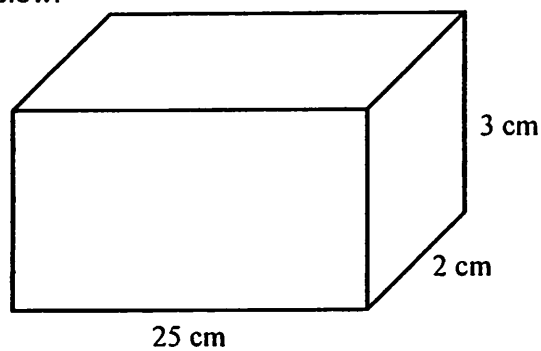

Ans: _____

19. Given that AB is a line of symmetry, complete the figure below.

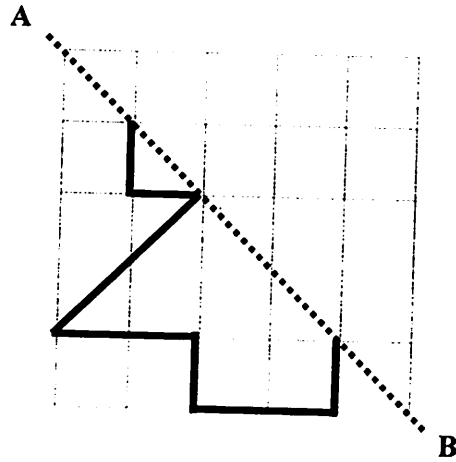

20. The figure shown below is a staircase made up of 1-cm cubes. What is the volume of the total number of cubes up to the 10th step?

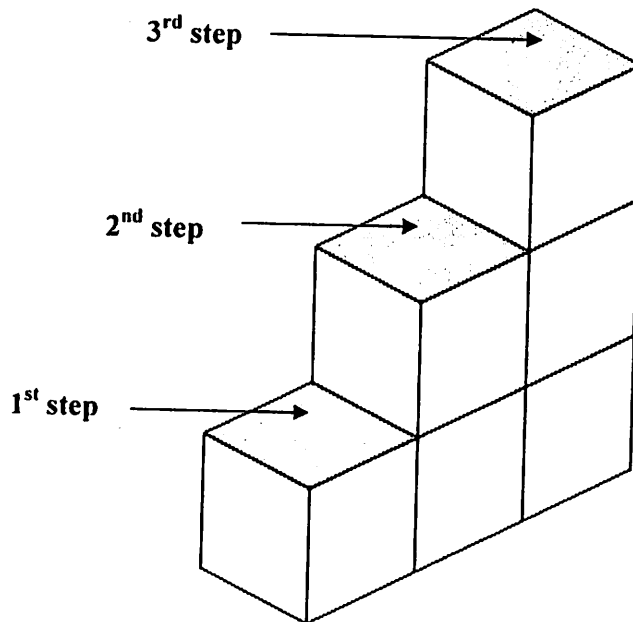

Ans: _____ cm³

21. Mrs Tan had a piece of cloth which was $7\frac{1}{4}$ m. She gave $3\frac{2}{5}$ m of the cloth to her sister. What was the length of the cloth left?

Ans: _____ m

22. Express $4\frac{3}{8}$ as a decimal.

Ans: _____

23. The cost of 9 curry puffs is \$9.45. What is the cost of 1 curry puff?

Ans: \$ _____

24. What is the measurement indicated by the arrow below?

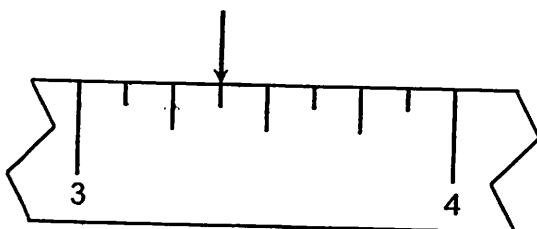

Ans: _____

25. Rod A is 1 m long. Rod B is 2 cm long.
Find the ratio of the length of Rod A to the length of Rod B.

Ans: _____

Questions 26 to 30 carry 2 marks each. Show your working clearly in the space provided for each question and write your answers in the space provided. For questions which require units, give your answers in the units stated. All diagrams are not drawn to scale. Answers in fractions or ratio must be expressed in the simplest form.

26. During a Speech Day rehearsal, 12 pupils were standing in a row at equal distances. The distance between the first and fourth pupil was 12m. What was the distance between the first and twelfth pupil?

Ans: _____m

27. Solve the following.

$$(55 + 65) - 100 + 100 \div 5 \times 2 = \underline{\quad?}$$

Ans: _____

28. In the working below, A, B, C, D, E and F are 2-digit numbers. If A is 20, B is the 4th multiple of A, C is the 3rd multiple of 11, D is the volume of a cube with length of 4 units, and F is the 4th multiple of 11, what is E?

$$\begin{array}{r}
 \begin{array}{|c|} \hline A \\ \hline \end{array}
 \begin{array}{|c|} \hline B \\ \hline \end{array} \\
 + \begin{array}{|c|} \hline C \\ \hline \end{array}
 \begin{array}{|c|} \hline D \\ \hline \end{array} \\
 \hline
 \begin{array}{|c|} \hline E \\ \hline \end{array}
 \begin{array}{|c|} \hline F \\ \hline \end{array} \\
 \hline
 \end{array}$$

Ans: _____

29. The capacity of a rectangular tank is 432 m^3 . The bottom of the tank measures 6 m by 3 m. It is then filled with some water. The height of the tank is 3 times the height of the water. What is the height of the water?

Ans: _____ m

30. Extend the tessellation by drawing 2 more unit shapes.

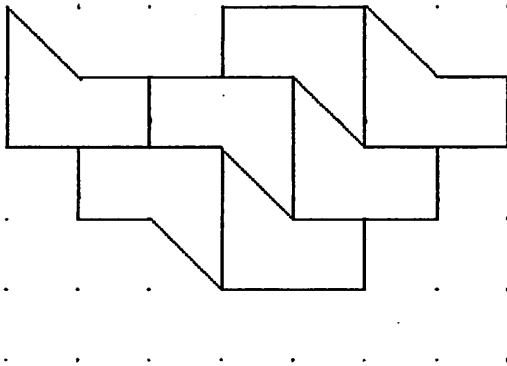

End of Paper-
☺ Please check your work carefully ☺

Setters: Mr Ho Kai Huat
Ms Lee Suan Khim
Mr Jonathan Teo



**RAFFLES GIRLS' PRIMARY SCHOOL
SEMESTRAL ASSESSMENT 1
MATHEMATICS (PAPER 2)
PRIMARY 5**

Name: _____ ()

Form class: P5 _____ Banded Math Class: P5 _____

Date: 10 May 2011

Duration: 1 h 40 min

Your Score (Out of 60 marks)		
	Banded Math Class	Level
Highest Score		
Average Score		

INSTRUCTIONS TO CANDIDATES

1. Do not turn over this page until you are told to do so.
2. Follow all instructions carefully.
3. Answer **ALL** questions and show all working clearly.
4. The use of calculator is allowed for this paper.

Questions 1 to 5 carry 2 marks each. Show your working clearly in the space provided for each question and write your answers in the spaces provided. Figures are not drawn to scale. For questions which require units, give your answers in the units stated. (10 marks)

1. The breadth of a rectangle is $\frac{1}{3}$ of its length.
If the perimeter of the rectangle is 120cm, what is the area of the rectangle?

Ans: _____ cm² [2]

2. Write down all the common multiples of 3 and 8 that are smaller than 50.

Ans: _____ [2]

3. Nicole had \$63 at first. She spent \$28 of her money.
What fraction of her money was left?
(Express the answer in its simplest form)

Ans: _____ [2]

4. The figure below is made up of 3 equilateral triangles and 3 squares. Find the ratio of the length AB to length CD to length EF. (Express the answer in its simplest form)

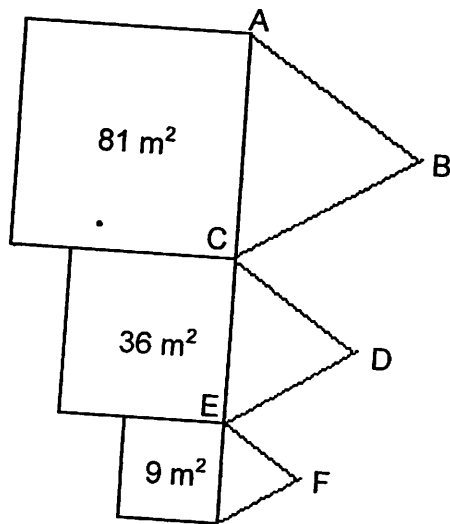

Ans: _____ [2]

5. The area of the triangle ABC is _____ cm^2 .

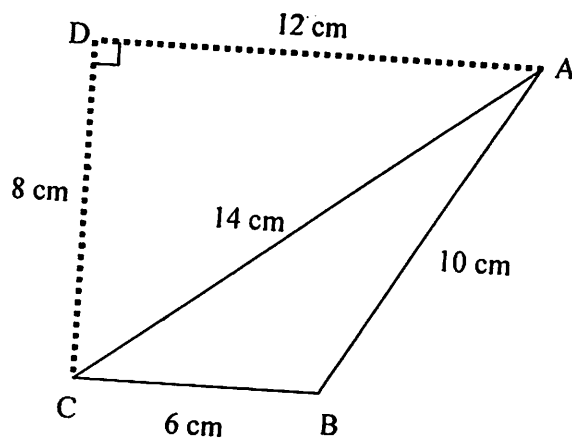

Ans: _____ [2]

For questions 6 to 18, show your working clearly in the space provided for each question and write your answers in the spaces provided. Figures are not drawn to scale. The number of marks available is shown in the brackets [] at the end of each question or part-question. (50 marks)

6. 2 machines took 14 minutes to print a magazine.
How long would it take for 7 machines to print a magazine?

Ans: _____ [3]

7. In a library, the ratio of the number of fiction books to the number of reference books was 3:7. After buying 126 fiction books, the ratio of the number of fiction books to the number of reference books was 3:4.
How many fiction books were there in the end?

Ans: _____ [3]

8. In the figure below, ABCD and BEGH are squares. CDH and BFH are triangles. Find the total shaded areas.

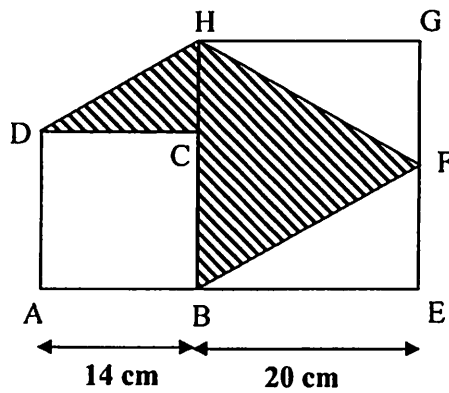

Ans: _____ [3]

9. Alicia had some beads. She gave Bernice half of the beads and 2 more. Then she gave half of the remaining beads and 3 more to Cindy. If Alicia had 9 beads after this, how many beads had Alicia at first?

Ans: _____ [4]

10. Mr Lim had some stickers and stamps for his class. The number of stickers was half as many as the number of stamps. After each pupil in the class had received 3 stickers and 8 stamps from Mr Lim, he had 39 stickers and 2 stamps left. What was the total number of stickers and stamps Mr Lim had at first?

Ans: _____ [4]

11. A cubical container of edge 8 cm was filled to the brim with water. The water was then poured to a rectangular tank that already had some water in it. The ratio of the volume of the empty cubical container to the volume of water in the rectangular tank was then 4:7. Find the volume of water that was in the rectangular tank at first.

Ans: _____ [3]

12. Michelle went shopping and spent \$225 on a watch.
 She used $\frac{5}{6}$ of her remaining money to buy a dress.
 She was then left with $\frac{2}{15}$ of her initial amount of money.
 How much money did she have at first?

Ans: _____ [3]

13. The figure below is made up of 5 identical rectangles, 2 identical squares and 1 triangle. Find the area of the figure.

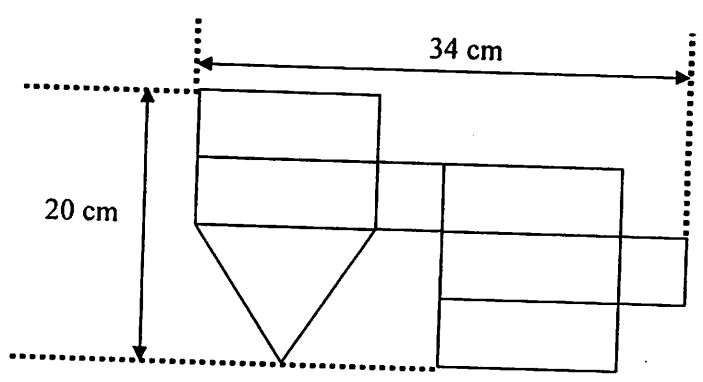

Ans: _____ [4]

14. A basket with 80 apples had a mass of 1320g. The same basket with 60 oranges had a mass of 1850g. If the mass of each orange is 2 times the mass of an apple, find the mass of the empty basket.

Ans: _____ [4]

15. Chloe paid \$3884.55 for 1 television set, 1 laptop and 3 chairs.
The television set cost \$520 more than the laptop.
Each chair cost \$899.90 less than the television set.
How much did the television set cost?

Ans: _____ [4]

16. Jason formed the following pattern using 1-cm square.

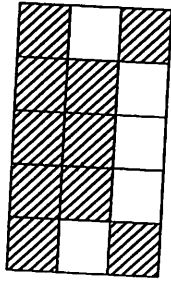

Pattern 1

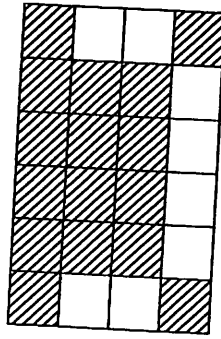

Pattern 2

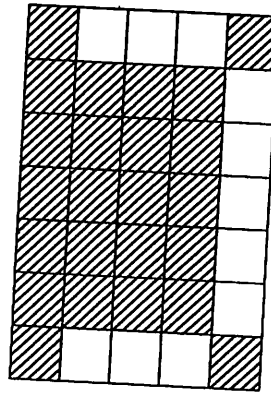

Pattern 3

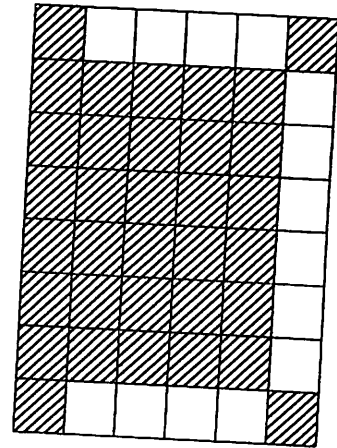

Pattern 4

(a) How many shaded squares are there in pattern 55?

(b) How many squares are there in pattern 250?

Ans: (a) _____ [3]

(b) _____ [2]

17. In a concert, $\frac{5}{6}$ of the audience were adults and the rest were children. $\frac{1}{4}$ of the adults were men and $\frac{3}{8}$ of the children were girls. If there were 450 more female than male audience in the concert, how many women were there?

Ans: _____ [5]

18. Andy and Betty saved a fixed amount every day. Betty, who started saving earlier, saved \$4 each day. By the 10th day of Betty's savings, Andy had saved \$18. By the 16th day of Betty's savings, Andy had saved \$54.

(a) Find the ratio of Andy's savings to Betty's savings.
(leave your answer in the simplest form)

(b) On which day of Betty's savings will Andy save the same amount as Betty?

Ans: (a) _____ [2]

(b) _____ [3]

-End of Paper-
Please check your work carefully ☺

Setters: Mr Ho Kai Huat
Ms Lee Suan Khim
Mr Jonathan Teo

RGPS P5 SA1 Mathematics 2011 Answer Key (Paper 1)

Updated: 13 May 2011

Section A (1m each for Q1-10; 2m each for Q11-15)

1) 4	6) 1	11) 2
2) 3	7) 2	12) 1
3) 4	8) 4	13) 4
4) 4	9) 3	14) 3
5) 4	10) 3	15) 4

Section B (1 mark each)

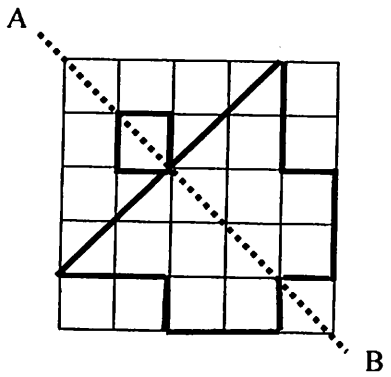
16) 513 820, 513 082, 231 058, 213058	21) $3 \frac{17}{20}$
17) 0.1 Or equivalent	22) 4.375
18) 12	23) 1.05
19) 	24) 3.375
20) 55	25) 50 : 1

Section B (2 marks each)

26) Distance b/w 2 pupils $\rightarrow 12\text{m} \div 3$ (M1) $= 4\text{m}$	
Distance b/w 1 st & 12 th pupil $\rightarrow 4\text{m} \times 11$ $= 44\text{m}$ (A1)	
27) 60 (A2 - either right or wrong)	
28) $20 + 33 + 1 = 54$ (M1, A1) (A2 if all values indicated in the boxes correctly)	
29) $6 \times 3 = 18$ $432 \div 18 = 24$ (M1) $24 \div 3 = 8$ (A1)	$6 \times 3 = 18$ $432 \div 3 = 144$ (M1) $144 \div 18 = 8$ (A1)
30)	
A1 for each correct unit shape drawn	

RGPS P5 SA1 Mathematics 2010 Answer Key (Paper 2)

2m each: Q1 – Q5

3m each: Q6 – Q8, Q11 – Q12

4m each: Q9 – Q10, Q13 – Q15

5m each: Q16 – Q18

<p>1) $120\text{cm} \div 8 = 15\text{cm}$ (M1) $15\text{cm} \times 3 = 45\text{cm}$ $15\text{cm} \times 45\text{cm} = \underline{675\text{cm}^2}$(A1)</p>	<p>$120 \div 2 = 60$ $60 \div 4 = 15$ (M1) $15 \times 45 = \underline{675 \text{ cm}^2}$ (A1)</p>	
<p>2) 24, 48 (A2 - either right or wrong)</p> <p>or:</p> <p>A2 awarded as long as answers are clearly shown in working. No marks deducted for transfer errors.</p>		
<p>3) $63 - 28 = 35$ (M1) $\frac{35}{63} = \frac{5}{9}$ (A1)</p>	<p>$63 - 28 = 35$ (M1) $35 \div 7 = 5$ $63 \div 7 = 9$ $\frac{5}{9}$ (A1)</p> <p>or:</p> <p>$\frac{63}{63} - \frac{28}{63} = \frac{35}{63}$ (M1) $\frac{35}{63} = \frac{5}{9}$ (A1)</p> <p>(No answer mark if \$ is added.)</p>	<p>$\frac{28}{63} = \frac{4}{9}$ $\frac{9}{9} - \frac{4}{9} = \frac{5}{9}$ (M1, A1)</p>
<p>4) $3 \times 3 = 9$ $6 \times 6 = 36$ $9 \times 9 = 81$ (M1 for listing all three steps correctly)</p> <p>$9:6:3 = 3:2:1$ (A1)</p>	<p>M1 awarded if all 3 lengths are clearly shown in diagram.</p>	

5) Area of triangle ABC $\rightarrow \frac{1}{2} \times 6\text{cm} \times 8\text{cm}$ (M1)

$= \underline{24\text{ cm}^2}$ (A1)

or:

(Pupil added Point E to form a rectangle)

Area of rectangle = 12×8
 $= 96\text{ cm}^2$

Area of triangle ADC = $\frac{1}{2} \times 12 \times 8$
 $= 48\text{ cm}^2$

Area of triangle ABE = $\frac{1}{2} \times 8 \times 6$
 $= 24\text{ cm}^2$

Area of triangle ABC = $96 - 48 - 24$ (M1)
 $= \underline{24\text{ cm}^2}$ (A1)

6) 2 machines \rightarrow 14 min
 1 machine \rightarrow $14\text{ min} \times 2 = 28\text{ min}$ (M1)
 7 machines \rightarrow $28 \div 7 = \underline{4\text{ min}}$ (M1, A1)

or:

The first M1 is awarded only if the time taken for 1 machine is shown.

7) Before After

F : R F : R
 3 : 7 3 : 4

* No additional reference books were bought

*(3x 4) (7 x 4) *(3x 7) (4 x 7)

12 : 28 21 : 28

$21 - 12 = 9$

9 units \rightarrow 126 books

1 unit \rightarrow $126\text{ books} \div 9 = 14\text{ books}$ (M1)

21 units \rightarrow $21 \times 14\text{ books} = \underline{294\text{ books}}$ (M1, A1)

or:

Alternative for last step (2nd M1, A1):

$14 \times 12 = 168$

$168 + 126 = \underline{294}$ (M1, A1)

(Methods using simultaneous equations and fractions also accepted.)

8)

$$\begin{aligned} \text{Area of bigger triangle} &\rightarrow \frac{1}{2} \times 20 \text{ cm} \times 20 \text{ cm} && \text{(M1)} \\ &= 200 \text{ cm}^2 \end{aligned}$$

$$\begin{aligned} \text{Area of smaller triangle} &\rightarrow \frac{1}{2} \times 14 \text{ cm} \times 6 \text{ cm} && \text{(M1)} \\ &= 42 \text{ cm}^2 \end{aligned}$$

$$\begin{aligned} \text{Total shaded areas} &\rightarrow 200 \text{ cm}^2 + 42 \text{ cm}^2 \\ &= \underline{242 \text{ cm}^2} \text{(A1)} \end{aligned}$$

9)

$$\begin{aligned} \text{Half of remaining beads} &\rightarrow 9 + 3 \\ &= 12 \end{aligned}$$

$$\begin{aligned} \text{Remaining beads} &\rightarrow 12 + 12 && \text{(M1)} \\ &= 24 \end{aligned}$$

$$\begin{aligned} \text{Half of beads at first} &\rightarrow 24 + 2 && \text{(M1)} \\ &= 26 \end{aligned}$$

$$\begin{aligned} \text{Beads at first} &\rightarrow 26 + 26 && \text{(M1)} \\ &= \underline{52} && \text{(A1)} \end{aligned}$$

or:

$$\begin{aligned} 9 + 3 &= 12 \\ 12 + 2 &= 14 && \text{(M1)} \\ 14 \times 2 &= 28 && \text{(M1)} \\ 12 \times 2 &= 24 && \text{(M1)} \\ 28 + 24 &= \underline{52} && \text{(A1)} \end{aligned}$$

13) Method 1

Length of square -> 5 cm
 Length of rectangle -> 12 cm

Area of 2 squares -> $(5 \text{ cm} \times 5 \text{ cm}) \times 2$ (M1)
 $= 50 \text{ cm}^2$

Area of 5 rectangles -> $(12 \text{ cm} \times 5 \text{ cm}) \times 5$ (M1)
 $= 300 \text{ cm}^2$

Area of triangle -> $\frac{1}{2} \times 12 \text{ cm} \times 10 \text{ cm}$ (M1)
 $= 60 \text{ cm}^2$

Total area -> $50 \text{ cm}^2 + 300 \text{ cm}^2 + 60 \text{ cm}^2$
 $= \underline{410 \text{ cm}^2}$ (A1)

Method 2

square -> $5 \text{ cm} \times 5 \text{ cm} = 25 \text{ cm}^2$
 2 squares -> $25 \text{ cm}^2 \times 2 = 50 \text{ cm}^2$ (M1)

rectangle -> $12 \text{ cm} \times 5 \text{ cm} = 60 \text{ cm}^2$
 5 rectangles -> $60 \text{ cm}^2 \times 5 = 300 \text{ cm}^2$ (M1)

triangle -> $\frac{1}{2} \times 12 \text{ cm} \times 10 \text{ cm} = 60 \text{ cm}^2$ (M1)

$50 \text{ cm}^2 + 300 \text{ cm}^2 + 60 \text{ cm}^2 = \underline{410 \text{ cm}^2}$ (A1)

Method 3

$12 \text{ cm} \times 5 \text{ cm} = 60 \text{ cm}^2$
 $60 \text{ cm}^2 \times 6 = 360 \text{ cm}^2$ (M2)

$5 \text{ cm} \times 5 \text{ cm} \times 2 \text{ cm} = 50 \text{ cm}^2$ (M1)

$360 \text{ cm}^2 + 50 \text{ cm}^2 = \underline{410 \text{ cm}^2}$ (A1)

14) Mass of 1 orange -> Mass of 2 apples
 Mass of 60 oranges -> $60 \times 2 =$ Mass of 120 apples
 Mass of the basket with 120 apples -> 1850 g
 Mass of basket with 80 apples -> 1320 g

Mass of 40 apples -> $1850 \text{ g} - 1320 \text{ g} = 530 \text{ g}$ (M1)

Mass of 80 apples -> $530 \text{ g} \times 2$ (M1)
 $= 1060 \text{ g}$

Mass of empty basket -> $1320 \text{ g} - 1060 \text{ g}$ (M1)
 $= \underline{260 \text{ g}}$ (A1)

or:

$530 \div 20 = 26.5$ (M1)

$26.5 \times 60 = 1590$ (M1)

$1850 - 1590 = \underline{260 \text{ g}}$ (M1, A1)

15)

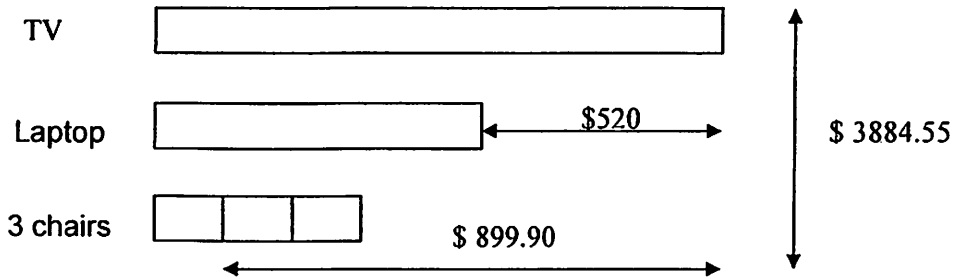

Method 1

$$\$899.90 - \$520 = \$379.90$$

$$\$899.90 + \$379.90 = \$1279.80 \quad (\text{M1})$$

$$\$3884.55 - \$1279.80 = \$2604.75 \quad (\text{M1})$$

$$\$2604.70 \div 5 = \$520.95 \quad (\text{M1})$$

$$\$520.95 + \$899.90 = \underline{\$1420.85} \quad (\text{A1})$$

Method 2

$$\$899.90 \times 3 = \$2699.70$$

$$\$2699.70 + \$520 = \$3219.70 \quad (\text{M1})$$

$$\$3219.70 + \$3884.55 = \$7104.25 \quad (\text{M1})$$

$$\$7104.25 \div 5 = \underline{\$1420.85} \quad (\text{M1, A1})$$

or:

$$(\$3884.55 + 2699.7) - (520 \times 4) = 4504.25 \quad (\text{M1})$$

$$4504.25 \div 5 = 900.85 \quad (\text{M1})$$

$$900.85 + 520 = \underline{\$1420.85} \quad (\text{M1, A1})$$

16a) Method 1

$$(55 + 1) \times (55 + 2) = 3192 \quad (\text{M1})$$
$$3192 + 4 = \underline{3196} \quad (\text{M1, A1})$$

Method 2

$$59 \times 57 = 3363 \quad (\text{M1})$$
$$55 \times 2 = 110$$
$$110 + 57 = 167 \quad (\text{M1})$$
$$3363 - 167 = \underline{3196} \quad (\text{A1})$$

Method 3

$$59 \times 57 = 3363 \quad (\text{M1})$$
$$55 \times 3 = 165$$
$$165 + 2 = 167 \quad (\text{M1})$$
$$3363 - 167 = \underline{3196} \quad (\text{A1})$$

Method 4

Listing:

Pattern 5 → 46
Pattern 6 → 60
Pattern 7 → 76

} Correct start for frst 3

"
"
"
"
"

} Correct listing

Pattern 54 → 3084
Pattern 55 → 3196 (A1)

16b) Method 1

$$252 \times 254 = \underline{64008} \quad (\text{M1, A1})$$

Method 2

$$253 \times 253 = 64009$$
$$64009 - 1 = \underline{64008} \quad (\text{M1, A1})$$

17) $\frac{5}{6} \times \frac{1}{4} = \frac{5}{24}$ (men)

$\frac{5}{6} \times \frac{3}{4} = \frac{15}{24}$ (women)

$\frac{1}{6} \times \frac{3}{8} = \frac{3}{48}$ (girls)

$\frac{1}{6} \times \frac{5}{8} = \frac{5}{48}$ (boys)

$\frac{15}{24} + \frac{3}{48} = \frac{33}{48}$ (females) OR $\frac{11}{16}$ (M1)

$1 - \frac{33}{48} = \frac{15}{48}$ (male) $\frac{5}{16}$ (M1)

$33 - 15 = 18$ $11 - 5 = 6$ (M1)

$450 \div 18 = 25$ $450 \div 6 = 75$ (M1)

$30 \times 25 = \underline{750}$ $10 \times 75 = \underline{750}$ (A1)

18a) $54 - 18 = 36$
 $36 \div 6 = 6$ (M1)
 $6 : 4$
 $= \underline{3 : 2}$ (A1)

18b) $16 \times 4 = 64$ OR $4 \times 10 = 40$
 $64 - 54 = 10$ (M1) $40 - 18 = 22$ (M1)
 $10 \div 2 = 5$ (M1) $22 \div 2 = 11$ (M1)
 $5 + 16 = \underline{21}$ (A1) $10 + 11 = \underline{21}$ (A1)

OR Listing :

Day	10	11	12	13	14	15	16	17	18	19	20	21
A	40	44	48	52	56	60	64	68	72	76	80	84
B	18	24	30	36	42	48	54	60	66	72	78	84

Correct start for first 3 → M1
 (Either for Day 11-13 or Day 17-19)

Able to show 5 days after Day 16 → M1

Ans : 84 (A1)