



**Catholic High School  
End-of-Year Examination 2011  
Mathematics  
Primary 5**

**PAPER 1**

**(BOOKLET A)**

Name : \_\_\_\_\_ (     )

Class: Primary 5 \_\_\_\_\_

Date: 27 October 2011

15 questions

20 marks

Total Time for Booklets A and B: 50 min

**INSTRUCTIONS TO CANDIDATES**

Do not open this booklet until you are told to do so.

Follow all instructions carefully.

Shade your answers in the Optical Answer Sheet (OAS) provided.

You are not allowed to use a calculator.

Answer all questions.

Questions 1 to 10 carry 1 mark each. Questions 11 to 15 carry 2 marks each. For each question, four options are given. One of them is the correct answer. Make your choice (1, 2, 3 or 4). Shade the correct oval on the Optical Answer Sheet. All figures are not drawn to scale. (20 marks )

---

1. Round off 5 609 584 to the nearest thousand.

- (1) 5 600 000
  - (2) 5 609 000
  - (3) 5 610 000
  - (4) 6 000 000
- 

2. How many hundreds must be added to 24 000 to make 50 000?

- (1) 26
  - (2) 260
  - (3) 2 600
  - (4) 26 000
- 

3. Find the value of  $(15 \times 5) - (56 \div 7) + 36$ .

- (1) 31
  - (2) 89
  - (3) 103
  - (4) 251
- 

4. Express  $\frac{4}{25}$  as a percentage.

- (1) 0.016%
  - (2) 0.16%
  - (3) 1.6%
  - (4) 16 %
- 

(Go to the next page)

5. Three girls shared a sum of money in the ratio 5 : 4 : 3. If the smallest share is \$21, how much is the biggest share?

- (1) \$7
  - (2) \$28
  - (3) \$35
  - (4) \$84
- 

6. There are 40 pupils in a class. 55% of the pupils are boys. How many girls are there?

- (1) 18
  - (2) 20
  - (3) 22
  - (4) 24
- 

7. Find the product of  $2\frac{5}{8}$  and 4.

- (1)  $4\frac{1}{2}$
  - (2)  $6\frac{5}{8}$
  - (3)  $8\frac{5}{8}$
  - (4)  $10\frac{1}{2}$
- 

8. Find the average of 0.5 kg, 2.5 kg and  $\frac{3}{4}$  kg.

- (1) 1150 g
  - (2) 1250 g
  - (3) 1350 g
  - (4) 1450 g
- 

(Go to the next page)

9. Given that  $\angle y$  is thrice the size of  $\angle x$ , find  $\angle x$ .

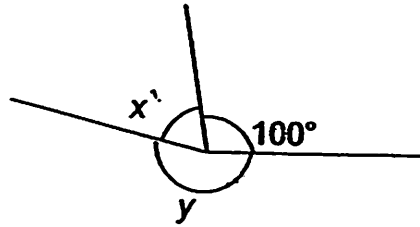

- (1)  $65^\circ$
- (2)  $130^\circ$
- (3)  $195^\circ$
- (4)  $260^\circ$

- 
10. ABCD is a rectangle. Find the area of the unshaded part.

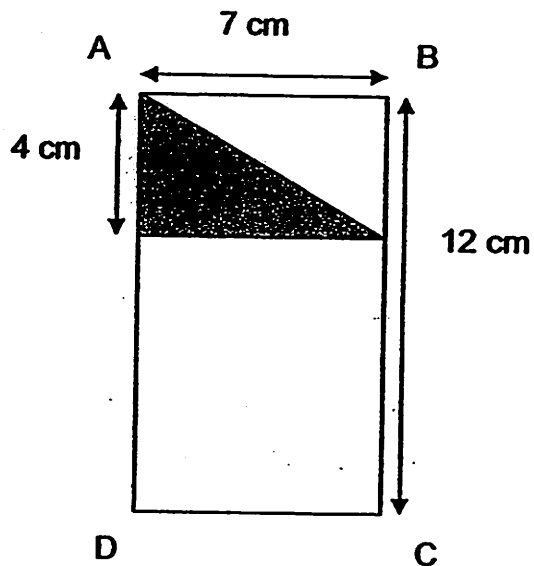

- (1)  $28 \text{ cm}^2$
- (2)  $56 \text{ cm}^2$
- (3)  $70 \text{ cm}^2$
- (4)  $84 \text{ cm}^2$

- 
11. If 75% of a number is 150, what is 60% of the number?

- ~~(1)~~ 60
- ~~(2)~~ 90
- ~~(3)~~ 120
- ~~(4)~~ 200

---

(Go to the next page)

12. There are 10 girls and 20 boys in a class. If each boy gets 15 sweets and each girl gets 30 sweets, what is the average number of sweets each child will get?

- (1) 25
  - (2) 20
  - (3) 30
  - (4) 40
- 

13. In a theme park, 40% of the people were adults and the rest were either senior citizens or children. There were twice as many children as senior citizens. What percentage of the people were senior citizens?

- (1) 10%
  - (2) 20%
  - (3) 30%
  - (4) 40%
- 

14. Tom spent 20% of his salary on a refrigerator and 60% of his remaining money on a television. If he was left with \$1600, how much was his salary?

- (1) \$8 000
  - (2) \$2 000
  - (3) \$5 000
  - (4) \$4 000
- 

(Go to the next page)

End of Booklet A

15. There are 660 apples and oranges at a fruit stall.  $\frac{3}{5}$  of the apples is equal to  $\frac{1}{2}$  of the oranges. Find the number of apples at the fruit stall.

---

(1)	180
(2)	300
(3)	330
(4)	360



**Catholic High School  
End-of-Year Examination 2011  
Mathematics  
Primary 5**

**PAPER 1**

**(BOOKLET B)**

Name : \_\_\_\_\_ ( )

Class: Primary 5 \_\_\_\_\_

Date: 27 October 2011

Booklet A	20
Booklet B	20
Total	40

15 questions

20 marks

Total Time for Booklets A and B: 50 min

**INSTRUCTIONS TO CANDIDATES**

Do not turn over this page until you are told to do so.

Follow all instructions carefully.

Show your working clearly as marks are awarded for correct working.

Write your answers in this booklet.

You are not allowed to use a calculator.

Questions 16 to 25 carry 1 mark each. Write your answers in the space provided.  
For questions which require units, give your answers in the units stated. All figures are not drawn to scale. (10 marks)

Do not write in this space

16. Express one hundred and twenty thousand, three hundred and forty-nine in numerals.

Ans: \_\_\_\_\_

17.  $50 \times 15 = 23 \times 15 + \underline{\hspace{2cm}} \times 15.$

Ans: \_\_\_\_\_

18. Arrange the following from the smallest to the largest.

$0.801, \frac{18}{100}, 0.081, 8\%$

Ans: \_\_\_\_\_

19. Find the shaded area of triangle PQR.

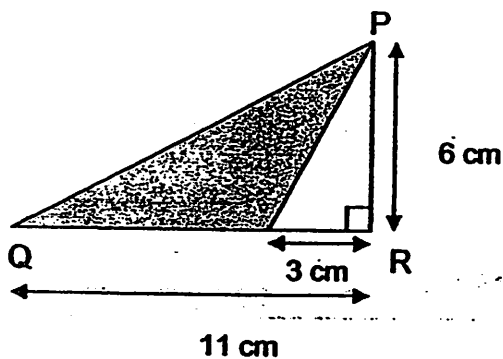

Ans: \_\_\_\_\_  $\text{cm}^2$

(Go to the next page)

20. 1075 m = \_\_\_\_\_ km

Ans: \_\_\_\_\_ km

Do not write  
in this space

21. ABD is an isosceles triangle and  $\angle CDA = 52^\circ$ .  $\angle DAC = 25^\circ$ . Find  $\angle CAB$ .

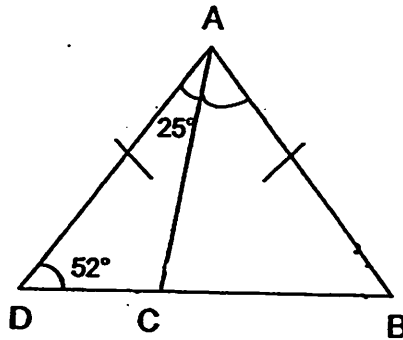

Ans: \_\_\_\_\_ °

22. If the average mass of 6 packets of rice is 0,8 kg, what is the total mass of the 6 packets of rice?

Ans: \_\_\_\_\_ kg

(Go to the next page)

23. Express 14% as a fraction in its simplest form.

Ans: \_\_\_\_\_

24. Find the ratio of 84 cm to 2 m in its simplest form.

Ans: \_\_\_\_\_

25. Express  $7\frac{8}{10}$  as a mixed number. Give your answer in its simplest form.

Ans: \_\_\_\_\_

**Total marks for questions 16 to 25**

(Go to the next page)

Do not write  
in this space

Questions 26 to 30 carry 2 marks each. Show your working clearly in the space below each question and write your answers in the spaces provided. For questions which require units, give your answers in the units stated. All figures are not drawn to scale. (10 marks)

Do not write in this space

26. Find the perimeter of an equilateral triangle of side  $\frac{2}{3}$  cm.

Ans: \_\_\_\_\_ cm

27. Jude cuts a string into 8 equal pieces in 14 seconds. How many seconds does he take to cut the same string into 10 equal pieces?

Ans: \_\_\_\_\_ seconds

28. A shop sells bags of 3 apples at \$2 for each bag. What is the greatest number of apples that can be bought with \$35?

Ans: \_\_\_\_\_

(Go to the next page)

29. Adam is 8 years old. His mother is 36 years older than him. In how many years' time will his mother be thrice as old as he?

Ans: \_\_\_\_\_ years

Do not write in this space

30. ABCD is a rectangle. What is the greatest number of 2-cm squares that can be cut from the following rectangle?

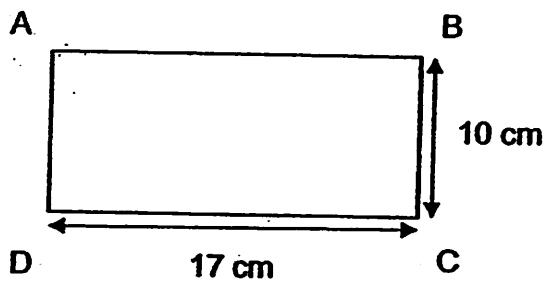

Ans: \_\_\_\_\_

End of Paper 1



**Catholic High School  
End-of-Year Examination 2011  
Mathematics  
Primary 5**

**PAPER 2**

Name : \_\_\_\_\_ ( )

Class: Primary 5 \_\_\_\_\_

Date: 27 October 2011

Duration: 1 h 40 min

Parent's Signature: \_\_\_\_\_

Paper 1 Booklet A	20
Paper 1 Booklet B	20
Paper 2	60
Total Marks	100

**INSTRUCTIONS TO CANDIDATES**

Do not turn over this page until you are told to do so.

Follow all instructions carefully.

Show your working clearly as marks are awarded for correct working.

Write your answers in this booklet.

You are allowed to use a calculator.

Questions 1 to 5 carry 2 marks each. Show your working clearly in the space below each question and write your answers in the spaces provided. All figures are not drawn to scale. For questions which require units, give your answers in the units stated. (10 marks)

Do not write in this space

1. 5 identical pencils cost \$9.65. How much will 95 such pencils cost?

Ans: \$ \_\_\_\_\_

2. The usual price of a shirt was \$30. It was later sold at a discount of 20%. What was the selling price of the shirt after the discount?

Ans: \$ \_\_\_\_\_

3. Helius kept ducks, cows and goats on his farm.  $\frac{1}{7}$  of his animals were goats. He had twice as many ducks as cows. Find the ratio of the number of goats to the number of ducks to the number of cows.

Ans: \_\_\_\_\_

(Go to the next page)

4. In the number line below, the value of X is  $\frac{1}{12}$  while the value of Z is  $\frac{1}{8}$ . Y is the midpoint between X and Z. Find the value of Y.

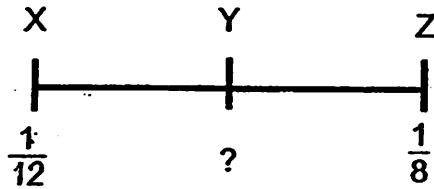

Ans: \_\_\_\_\_

5. The chairs in a hall were arranged in rows for a school concert. Each row had the same number of chairs. Ryan sat on one of the chairs. There were 6 chairs to his right and 8 chairs to his left. There were 5 rows of chairs in front of him and 5 rows of chairs behind him. How many chairs were there in the hall altogether?

Ans: \_\_\_\_\_

(Go to the next page)

Do not write in this space

For questions 6 to 18, show your working clearly in the space provided for each question and write your answers in the spaces provided. For questions which require units, give your answers in the units stated. All figures are not drawn to scale. The number of marks available is shown in brackets [ ] at the end of each question or part-question. (50 marks)

Do not write in this space

6. The shaded area of triangle ABC is  $\frac{4}{5}$  of the unshaded area. Find the area of triangle ABC.

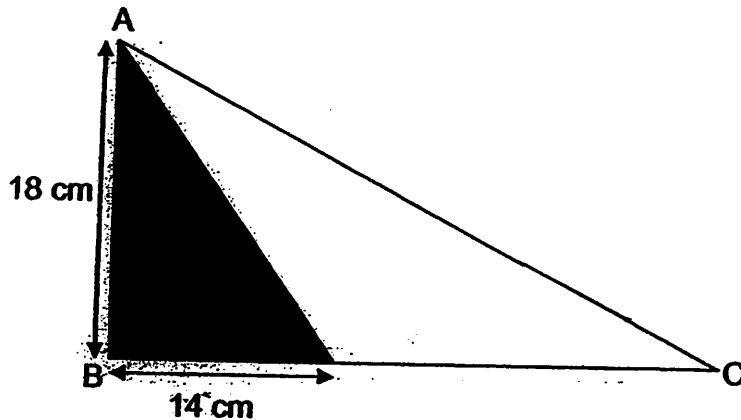

Ans: \_\_\_\_\_ [3]

7. A man earns \$7.50 per hour on weekdays and \$1.50 more per hour on Saturdays and Sundays. He works 8 hours each day. If he works every day except Friday, how much does he earn in a week?

Ans: \_\_\_\_\_ [3]

(Go to the next page)

8. PQRS is a parallelogram and XZS is a triangle. Find  $\angle XQR$ .

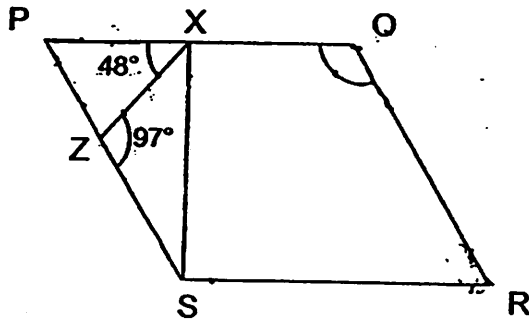

Ans: \_\_\_\_\_ [3]

9. Sean had twice as much money as his brother, George. After George spent \$20 and Sean received another \$50 from their mother, Sean had five times as much money as George. How much money did Sean have at first?

Ans: \_\_\_\_\_ [3]

(Go to the next page)

Do not write in this space

10. There were thrice as many children as adults in a bus. After 26 children had alighted, the ratio of the number of children to the number of adults became 2 : 5. How many children were there in the bus at first?

Do not write in this space

Ans: \_\_\_\_\_ [3]

11. The ratio of Adam's money to Bernard's money is 3 : 5. The ratio of Carl's money to Adam's money is 1 : 6. If Bernard had \$90 more than Carl, find the total sum of money shared by the three children.

Ans: \_\_\_\_\_ [3]

(Go to the next page)

12. ABC is a right angled triangle. 4 such identical triangles are used to form the square WXYZ. Find the perimeter of the square WXYZ.

Do not write in this space

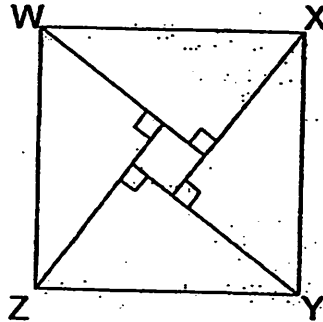
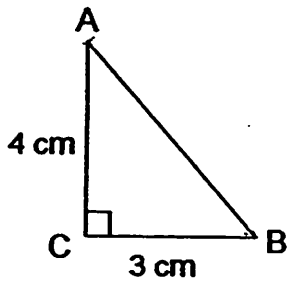

Ans: \_\_\_\_\_ [4]

(Go to the next page)

13. Collin was given some money to buy oranges. If he were to buy 12 oranges, he would be short of \$2.00. If he were to buy 3 oranges, he would have \$2.50 left. How many oranges can he buy with his money?

Do not w  
in this s

Ans: \_\_\_\_\_ [ 4 ]

(Go to the next page)

14. Aaron and Ben shared a sum of \$200. Aaron gave  $\frac{3}{5}$  of what he has to Ben. Ben later gave  $\frac{1}{5}$  of what he has back to Aaron. They ended up with equal amount of money. How much did Aaron have at first?

Do not write  
in this space

Ans: \_\_\_\_\_ [4]

(Go to the next page)

15. There are some coins in a box.  $\frac{1}{8}$  of them are 10¢ coins,  $\frac{1}{4}$  of them are 20¢ coins,  $\frac{3}{8}$  of them are 50¢ coins and the rest are \$1 coins. The total value of the coins is \$800.

(a) How many 50¢ coins are there?

(b) What is the total value of the 10¢ and 20¢ coins?

Do not write in this space

Ans: a) \_\_\_\_\_ [3]

Ans: b) \_\_\_\_\_ [2]

(Go to the next page)

16. Grey and white triangular tiles are used to form a sequence of patterns. The first four patterns are shown below.

Do not write in this space



Pattern 1



Pattern 2

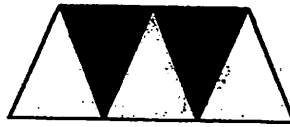

Pattern 3



Pattern 4

(a) Fill in the number of grey and white triangular tiles for pattern number 5 in the table provided below.

Pattern Number	Grey triangular tiles	White triangular tiles
1	0	1
2	1	2
3	2	3
4	3	4
5		

[2]

(b) In which pattern number will there be a total of 59 triangular tiles?

Ans: \_\_\_\_\_ [3]

(Go to the next page)

17. Vanessa earned \$0.80 for every box of cookies that she sold. She will also received a commission of \$17 for every 30 boxes of cookies sold. How many boxes of cookies did she sell if she earned a total of \$258?

Do not  
in this s

Ans: \_\_\_\_\_ [5]

Go to the next page)

18. A bag contains some red, blue, green and white marbles. 40% of the marbles are red. The number of blue marbles is  $\frac{3}{5}$  the number of red marbles. The ratio of the number of green marbles to white marbles is 3 : 2. There were 460 more red marbles than green marbles. How many marbles are there in the bag?

Do not write in this space

Ans: \_\_\_\_\_ [5]

- End of Paper 2 -

# ANSWER SHEET

## EXAM PAPER 2011

SCHOOL : CATHOLIC HIGH  
SUBJECT : PRIMARY 5 MATHEMATICS

TERM : SA2

Q1	Q2	Q3	Q4	Q5	Q6	Q7	Q8	Q9	Q10	Q11	Q12	Q13	Q14	Q15
3	2	3	4	3	1	4	2	1	3	3	2	2	3	2

- 16) 120349      17) 27      18) 0.081, 18/100, 0.801, 81%      19) 24cm<sup>2</sup>
- 20) 1.075km      21) 51°      22) 4.8kg      23) 7/50      24) 21:50
- 25) 7<sup>4</sup>/5      26) 2cm      27) 18 seconds      28) 51      29) 10 years
- 30) 40

### Paper 2

- 1) 5p → \$9.65  
1p → \$9.65 ÷ 5 = \$1.93  
95p → \$1.93 × 95 = \$183.35
- 2) 100% → \$30  
1% → 30 ÷ 100 = 0.3  
20% → 0.3 × 20 = 6  
Price → 30 - 6 = \$24
- 3) 1:4:2
- 4) 5/48
- 5) 1 row → 1 + 6 + 8 = 15 chairs  
11 rows → 15 × 11 = 165 chairs
- 6) 4u → 126cm<sup>2</sup>  
1u → 31.5  
9/5 → 31.5 × 9 = 283.5cm<sup>2</sup>
- 7) Weekday → 7.58 × 8 = 60 × 4 = \$240  
Weekends → 7.50 + 1.50 = \$9 × 8 = \$72  
\$72 × 2 = \$144  
\$144 + \$240 = \$384
- 8) ∠XQR → 180° - 49° = 131°
- 9) 100
- 10) 30
- 11) 9u → \$90  
1u → \$10  
17u → \$170
- 12) 1/2 × 4 × 3 = 6  
4 × 6 = 24  
1 × 1 = 1  
Area of square = 24 + 1 = 25cm<sup>2</sup>  
Side = √25 = 5cm  
Perimeter = 5 × 4 = 20cm
- 13) 9 oranges → \$4.50  
1 oranges → \$0.50  
3 oranges → \$1.50  
Amt of → \$1.50 + \$2.50 = \$4  
\$4 ÷ 0.5 = 8

14)  $4/5B \rightarrow \$100$   
 $1/5B \rightarrow \$25$   
 $5/5B \rightarrow \$125$   
 $1/5A \rightarrow 37.50$   
 $A \rightarrow 37.50 \times 5 = \$187.50$

15) a)  $1gp \rightarrow \$1.80$   
 $8u \rightarrow \$800$   
 $1u \rightarrow \$100$   
 $3u \rightarrow \$300$   
 $\$300 \div 0.5 = 600$   
b)  $\$100$

16) a) 4,5  
b)  $59 - 1 = 58$   
 $58 \div 2 = 29$   
 $29 + 1 = 30$

17)  $30 \times 80c = \$24$   
 $24 + 17 = 41$   
 $258 \div 41 = 6R 12$   
 $12 \div 0.8 = 15$   
 $(30 \times 6) + 15 = 180 + 15 = 195$

18)  $R = 40\%$   
 $B+G+W = 100 - 40 = 60\%$   
 $R = 5u = 40\%$   
 $1u = 40 \div 5 = 8\%$   
 $B = 3u = 3 \times 8 = 24\%$   
 $G+W = 60 - 24 = 36\%$   
 $G = 3/5 \times 36 = 21.6\%$   
 $W = 36 - 21.6 = 14.4\%$   
 $40 - 21.6 = 18.4\%$   
 $18.4\% = 460$   
 $1\% = 460 - 18.4 = 25\%$   
 $100\% = 25 \times 100 = 2500$