

METHODIST GIRLS' SCHOOL

Founded in 1887



END-OF-YEAR EXAMINATION 2011 PRIMARY 5 MATHEMATICS

PAPER 1 (BOOKLET A)

Total Time for Booklets A and B: 50 minutes

INSTRUCTIONS TO CANDIDATES

Do not turn over this page until you are told to do so.

Follow all instructions carefully.

Answer all questions.

Shade your answers in the Optical Answer Sheet (OAS)
Provided.

The use of calculators is NOT allowed.

Name: _____ ()

Class: Primary 5. _____

Date: 11 October 2011

This booklet consists of 6 printed pages including this page.

Questions 1 to 10 carry 1 mark each. Questions 11 to 15 carry 2 marks each. For each question, four options are given. One of them is the correct answer. Make your choice (1, 2, 3 or 4). Shade the correct oval (1, 2, 3 or 4) on the Optical Answer Sheet.

(20 marks)

1 What is the value of $24 + 72 \div 12 \times 2$?

- (1) 60
- (2) 36
- (3) 16
- (4) 4

2 The population of Blackmore City when rounded off to the nearest million is 1 million. Which of the following is the best estimate of the population size?

- (1) 955 000
- (2) 990 000
- (3) 1 005 000
- (4) 1 550 000

3 A basket weighs 0.6 kg. The mass of the basket and 4 papayas is 3.6 kg. Find the average mass of one papaya.

- (1) 0.75 kg
- (2) 0.84 kg
- (3) 0.90 kg
- (4) 1.05 kg

4 A total of 36 men, 60 women and 24 children attended a piano recital. What fraction of the audience were children?

- (1) $\frac{5}{1}$
- (2) $\frac{10}{3}$
- (3) $\frac{2}{1}$
- (4) $\frac{5}{4}$

(Go on to the next page)

- 5 A and B are mid-points of the sides of the rectangle. What fraction of the rectangle is shaded?

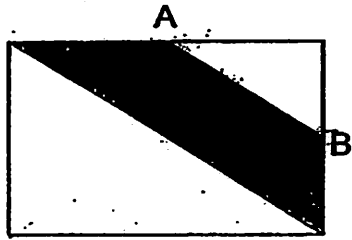

- (1) $\frac{1}{4}$
 (2) $\frac{3}{8}$
 (3) $\frac{5}{8}$
 (4) $\frac{3}{4}$

- 6 What is the area of the unshaded parts?

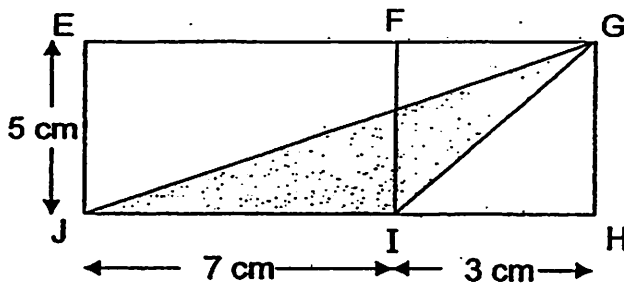

- (1) 25 cm^2
 (2) 45 cm^2
 (3) 32.5 cm^2
 (4) 52.5 cm^2

- 7 $3.06 \times 30 = 2.06 \times 30 + A \times 30$.
 What is the value of A?

- (1) 1
 (2) 2
 (3) 3
 (4) 4

(Go on to the next page)

8 Fatimah uses 250 ml of syrup and 1.5 l of water to make a jug of cranberry juice. How many litres of cranberry juice are there in 3 such jugs?

- (1) 1.75 l
- (2) 2.90 l
- (3) 4.75 l
- (4) 5.25 l

9 In the figure, not drawn to scale, $\angle y$ is 96° larger than $\angle x$. Find $\angle x$.

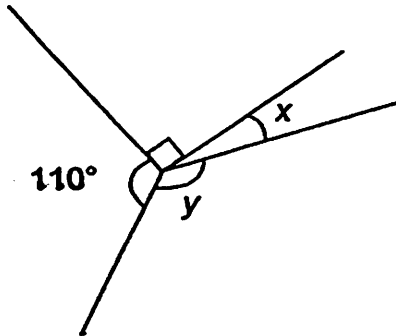

- (1) 32°
- (2) 36°
- (3) 40°
- (4) 64°

10 The figure below is not drawn to scale. ABCD is a rhombus and FB is a straight line. Given that $AB = AD$, find $\angle FDC$.

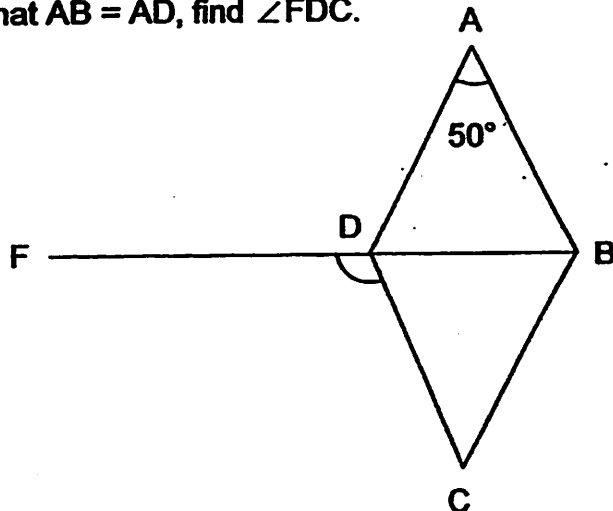

- (1) 65°
- (2) 100°
- (3) 115°
- (4) 130°

- 11 The average mass of a group of boys was 48 kg. When John joined the group, the new average mass of the group became 54 kg. If John weighed 72 kg, how many boys were there in the group in the end?

- (1) 9
- (2) 8
- (3) 6
- (4) 4

- 12 The figure shows a solid that is made up of cubes of side 2 cm. How many more cubes are needed to form a cuboid of sides 6 cm by 8 cm by 6 cm?

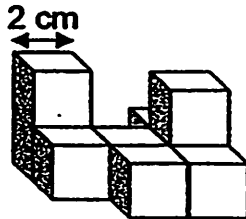

- (1) 18
 - (2) 19
 - (3) 27
 - (4) 28
- 13 May spent $\frac{1}{6}$ of her money on a storybook and \$18 on a wallet. She had $\frac{1}{3}$ of her money left. How much money did she have left?

- (1) \$6
- (2) \$12
- (3) \$24
- (4) \$36

(Go on to the next page)

- 14 The perimeter of rectangle is 60 cm. Its breadth is 14 cm. Find the ratio of its ~~width to its breadth~~

length to its breadth

- (1) 7 : 8
- (2) 7 : 9
- (3) 8 : 7
- (4) 23 : 14

- 15 60% of the buttons in a jar were round and the rest were square. Mrs Tan used 20% of the round buttons and $\frac{1}{4}$ of the square buttons. What percentage of the buttons were left in the jar?

- (1) 22%
- (2) 55%
- (3) 70%
- (4) 78%

METHODIST GIRLS' SCHOOL
Founded in 1887



END-OF-YEAR EXAMINATION 2011
PRIMARY 5 MATHEMATICS

PAPER 1
(BOOKLET B)

Total Time for Booklets A and B: 50 minutes

INSTRUCTIONS TO CANDIDATES

Do not turn over this page until you are told to do so.

Follow all instructions carefully.

Answer all questions.

Write your answers in this booklet.

The use of calculators is NOT allowed.

Name: _____ ()

Class: Primary 5. _____

Date: 11 October 2011

Paper 1 Booklet A	/ 20
Paper 1 Booklet B	/ 20
Paper 2	/ 60
TOTAL	/ 100

This booklet consists of 7 printed pages including this page.

Questions 16 to 25 carry 1 mark each. Questions 26 to 30 carry 2 marks each. Write your answers in the spaces provided. For questions which require units, give your answers in the units stated.

(20 marks)

- 16 Find the value of $5\,074 - 336$. Round off your answer to the nearest ten.

Ans: _____

- 17 The digit in the thousands and ones place is 4. The sum of all the digits is 10. What is the smallest 4-digit whole number?

Ans: _____

- 18 Arrange these fractions in decreasing order:

$$\frac{3}{10}, \frac{2}{7}, \frac{1}{3}$$

Ans: _____

- 19 A piece of ribbon is $\frac{3}{4}$ m long. What is the total length of 7 such ribbons?

Ans: _____ m

(Go on to the next page)

- 20 What is the missing number in the box?

$$\frac{13}{9} = 3 - \frac{\square}{9}$$

Ans: _____

- 21 Sean had $3\frac{5}{12}$ litres of milk. He used $2\frac{1}{6}$ litres of the milk to make some muffins and the rest to bake 2 sponge cakes. How much milk did he use to bake each sponge cake? Express your answer in the simplest form.

Ans: _____ l

- 22 The table below shows the marks scored by Jerry in 4 class tests. The average score is 63. What was Jerry's test score for Science?

Subject	Marks
English	60
Mother Tongue	69
Mathematics	58
Science	?

Ans: _____

- 23 Mrs Lim deposited \$4 200 in her bank account. The bank paid her an interest of 3% per year, how much would she have in the bank at the end of the year?

Ans: \$ _____

- 24 In the figure below, ABC is a straight line. Given that $\angle a$ is twice as big as $\angle b$, find $\angle a$.

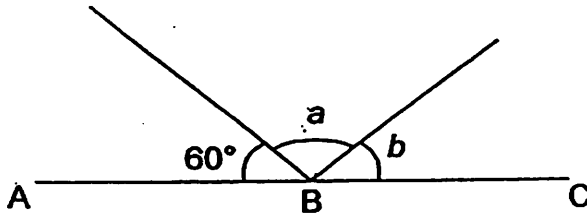

Ans: _____°

- 25 The figure below is not drawn to scale. AD and BF are straight lines. $\angle CDE$ is 78° and $\angle DEF$ is 141° . Find $\angle ACB$.

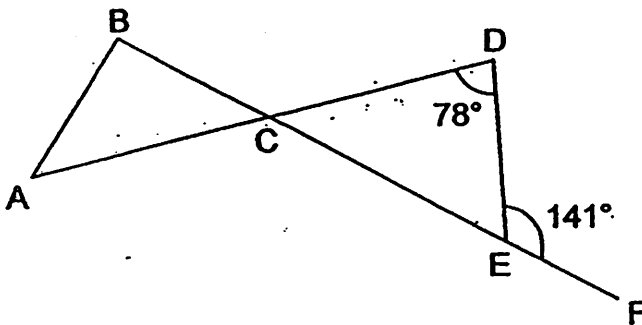

Ans: _____°

(Go on to the next page)

Questions 26 to 30 carry 2 marks each. Show your working clearly in the space provided for each question and write your answers in the spaces provided. For questions which require units, give your answers in the units stated.

(10 marks)

- 26 Jean and Samantha shared some money in the ratio 7 : 4. Jean received \$240 more than Samantha, how much money did they have altogether?

Ans: \$ _____

- 27 The area of the shaded figure WXYZ is 34 cm^2 . ZP is 6 cm and ZP is 3 times the size of XQ. What is the length of WY?

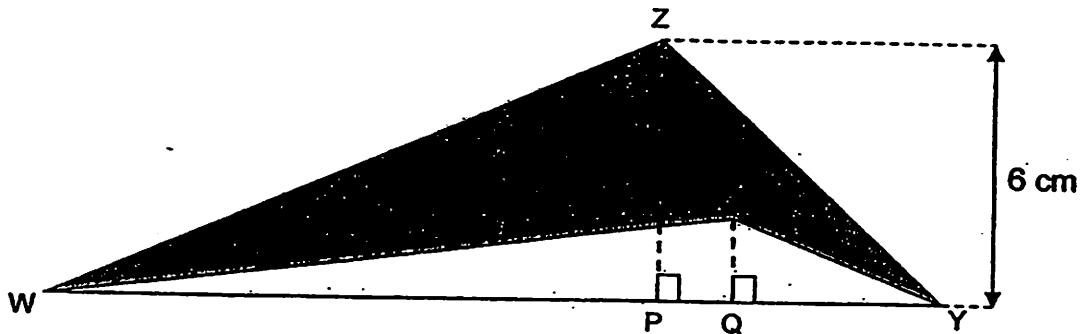

Ans: _____ cm

(Go on to the next page)

- 28 Mrs Tay bought some chicken with 30% of her money. She bought some vegetables with $\frac{1}{2}$ of the remaining money and had \$7 left. How much money did Mrs Tay have at first?

Ans: \$. _____

- 29 The 3 containers below contain the same amount of water. The volume of the water and objects in containers X and Y are as indicated on the diagram below. What is the volume of the water and object A in container Z?

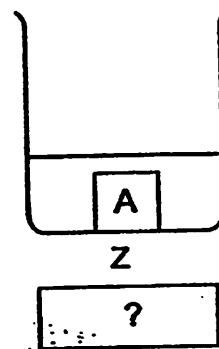
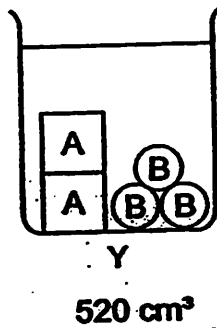
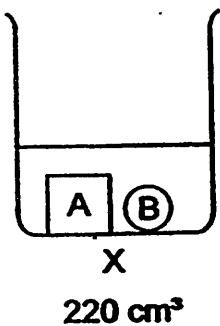

Ans: _____ cm³

- 30 Draw a triangle PQR in which $QR = 8 \text{ cm}$, $\angle PQR = 55^\circ$ and $\angle PRQ = 40^\circ$. Label your diagram clearly.



Q

End of Booklet B

METHODIST GIRLS' SCHOOL

Founded in 1887



END-OF-YEAR EXAMINATION 2011 PRIMARY 5 MATHEMATICS

PAPER 2

Total Time: 1 h 40 min

INSTRUCTIONS TO CANDIDATES.

Do not turn over this page until you are told to do so.

Follow all instructions carefully.

Answer all questions.

Write your answers in this booklet.

The use of an approved calculator is expected, where appropriate.

Name: _____ ()

Class: Primary 5. _____

Date: 11 October 2011

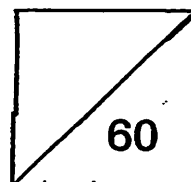

This booklet consists of 13 printed pages including this page.

Questions 1 to 5 carry 2 marks each. Show your working clearly and write your answers in the spaces provided. For questions which require units, give your answers in the units stated.

(10 marks)

- 1 Mary saves $\frac{3}{7}$ as much as Sammie. If Sammie saves \$140 more than Mary, how much do they save altogether?

Ans: \$ _____

- 2 Junita takes 25 minutes to make a gift card. She spent 3 hr 20 min to make all her gift cards. How many gift cards did she make altogether?

Ans: _____

- 3 The usual price of a bag is \$220. During the Great Singapore Sale, Mrs Ang bought the bag at a 30% discount. She had to pay 7% GST on the discounted price.

- (a) How much GST did she pay?
(b) How much did she pay for the bag, inclusive of GST?

30%
discount



Ans: (a) \$ _____

(b) \$ _____

(Go on to the next page)

- 4 The figure below is not drawn to scale. ABCD is a rhombus, BH, EG and DF are straight lines, $\angle BCE$ is 70° and $\angle FCH$ is 68° , find $\angle ABC$.

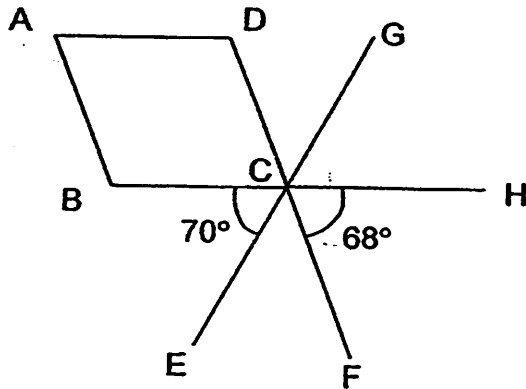

Ans: _____^o

- 5 The figure below is made up of cubes which are of the same size. What is the volume of the figure?

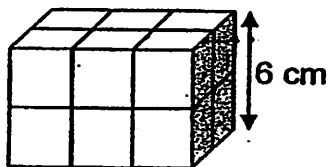

Ans: _____ cm^3

(Go on to the next page)

For questions 6 to 18, show your working clearly and write your answers in the space provided. The number of marks available is shown in brackets [] at the end of each question or part-question.

(50 marks)

- 6 Mr Wong sold 5 kg of rambutans and 4 kg of longans for \$40. Mrs Tan bought 4 kg of rambutans and 5 kg of longans. She paid for the fruits with ~~4 ten dollar~~ notes and received \$1.25 change. What was the price of 1 kg of longans?

1 kg of longans?

Ans: _____ [3]

- 7 Harry used $\frac{3}{5}$ of his money to buy a book which cost \$15. He spent the rest of his money on transport and food. He spent \$4 more on food than on transport. How much did he spend on food?

Ans: _____ [3]

(Go on to the next page)

- 8 In the figure below not drawn to scale, $AB = BE$ and $AD = DC$. Given that $\angle DAB$ is 28° and $\angle ADE$ is 92° , find $\angle EAD$.

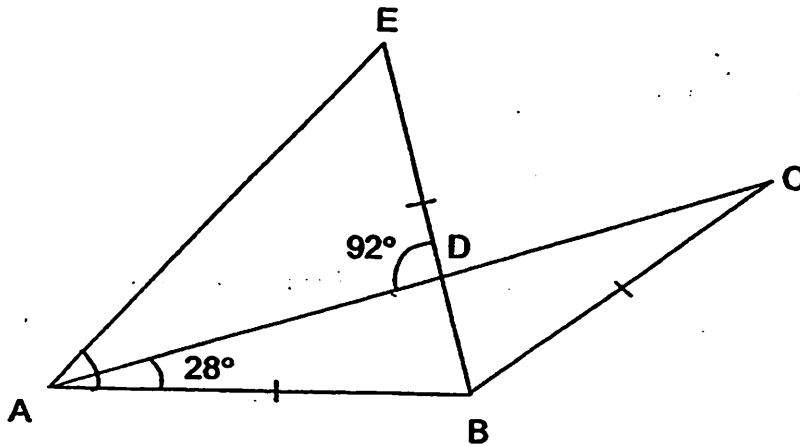

Ans: _____ [3]

- 9 There are $\frac{3}{5}$ as many 50-cent coins as 10-cent coins. The ratio of the number of 50-cent coins to the number of one-dollar coins is 4 : 7. What is the ratio of the number of 10-cent coins to the number of one-dollar coins?

Ans: _____ [3]

(Go on to the next page)

- 10 Ann measures the length of her classroom with her footsteps and finds that the classroom is 6.15 m long. Ann's foot is 20.5 cm long, how many footsteps did she take?



Ans: _____ [3]

- 11 The average height of 3 boys is 1.24 m. One more boy whose height is 1.16 m joins the group, what is the average height of the 4 boys?

Ans: _____ [3]

(Go on to the next page)

- 12 In the figure below, BC is a straight line.
(a) Draw a trapezium ABCD in which $AD \parallel BC$, $\angle ABC = 75^\circ$,
 $\angle BCD = 50^\circ$ and $CD = 5$ cm.
(b) What is the length of AD?

[3]

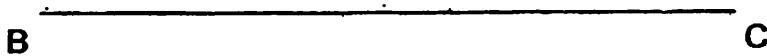

Ans: (b) _____ [1]

(Go on to the next page)

- 13 The figure below is not drawn to scale.
 FHIJ is a trapezium and GHIJ is a rhombus.
 GK is a straight line, $\angle IJK$ is 110° and $\angle FJG$ is 22° .

- (a) Find $\angle HFJ$
 (b) Find $\angle GHJ$

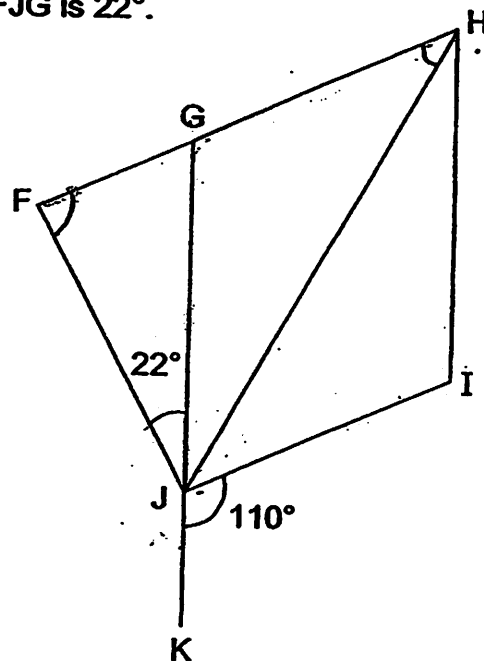

Ans: (a) _____ [2]

(b) _____ [2]

(Go on to the next page)

- 14 The figure below shows a rectangular container. It contained 1.76 litres of water.

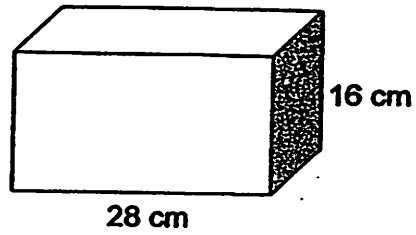

- (a) The perimeter of the shaded face is 58 cm. What is the area of the shaded face?
- (b) How much more water must be poured in so that the water level reaches 10 cm? Give your answer in litres.

Ans: (a) _____ [2]

(b) _____ [2]

(Go on to the next page)

- 15 The figure below is formed using squares and dots.

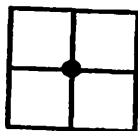

Pattern 1

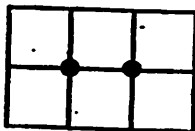

Pattern 2

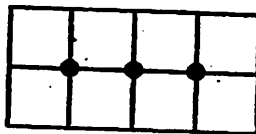

Pattern 3

Pattern number	Number of squares	Number of dots
1	4	1
2	6	2
3	8	3
:	:	:
5	?	

- (a) How many squares are there in Pattern 5?
 (b) How many dots will you find in a pattern which has 40 squares?
 (c) What is the total number of squares and dots in Pattern 15?

Ans: (a) _____ [1]

(b) _____ [2]

(c) _____ [2]

(Go on to the next page)

- 16 Devi and Siti had some savings. Together, they donated a total sum of \$50 to Happy Joy Charity. Devi donated $\frac{1}{4}$ of her savings. After making a donation of \$13, Siti found that she had \$17 more in her savings than Devi.
- (a) How much money did Devi have at first?
- (b) How much savings did both of them have left?

Ans: (a) _____ [2]

(b) _____ [3]

(Go on to the next page)

- 17 Megan, Nora and Olivia shared the cost of a rental flat. Megan paid $\frac{2}{5}$ of the total amount paid by Nora and Olivia. The ratio of the amount paid by Nora to the total amount paid by Megan and Olivia was 1 : 3.
- (a) What is the ratio of the rent paid by Megan to the rent paid by Nora to the rent paid by Olivia?
- (b) Given that Megan paid \$35 more than Nora, how much rent did the 3 girls pay for the flat?

Ans: (a) _____ [2]

(b) _____ [3]

(Go on to the next page)

- 18 Watten School set aside a sum of money for their school musical. 40% of the money was allocated to stage decorations, $\frac{1}{4}$ of the remaining sum was allocated to costumes and the rest of the money to merchandise. One donor decided to sponsor part of the cost of the musical and thus the money allocated for the musical increased by 30%.
The initial sum allocated for costumes is \$2 850.

- (a) What was the amount of money allocated for the school musical at first?
(b) How much money did the school receive from the donor?
(c) How much money was allocated to merchandise in the end?

Ans: (a) _____ [2]

(b) _____ [1]

(c) _____ [2]

End of Paper

ANSWER SHEET

EXAM PAPER 2011

SCHOOL : MGS
SUBJECT : PRIMARY 5 MATHEMAEICS

TERM : SA2

Q1	Q2	Q3	Q4	Q5	Q6	Q7	Q8	Q9	Q10	Q11	Q12	Q13	Q14	Q15
2	3	1	1	2	3	1	4	1	3	4	3	2	3	4

- 16)4740 17)4024 18) $1/3, 3/10, 2/7$ 19) $5\frac{1}{4}m$ 20)14
 21) $5/8$ 22)65 23)\$4326 24) 80° 25) 63°
 26)\$880 27)17cm 28)\$20 29)140cm³

30)

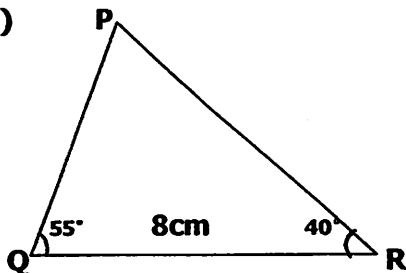

Paper 2

1) $4u \rightarrow 140$

$1u \rightarrow 140 \div 4 = 35$

$10u \rightarrow 35 \times 10 = 350$

They save \$350 altogether.

3)a) $100 - 30 = 70$

$220 \times 70\% = 154$

$154 \times 7\% = 10.78$

The GST she has to pay is \$10.78

b) $154 + 10.78 = 164.78$

She paid \$164.78

5) $6 \div 2 = 3$

$3 \times 3 = 9$

$9 \times 6 \times 6 = 324$

The volume is 324cm³

2) $3hr \rightarrow 180min$

$180 + 20 = 200$

$3hr\ 20min \rightarrow 200min$

$200 \div 25 = 8$

She made 8

4) $(180 - 68) \div 2 = 56 (\angle DBC)$

$56 \times 2 = 112 (\angle ABC)$

$\angle ABC$ is 112°

6) $1.25 \times 4 = 5$

$38.75 - 5 = 33.75$

$33.75 \div 9 = 3.75$

1 kg of longans is \$3.75

7) $15 \div 3 = 5$
 $1u \rightarrow 5$
 $5 \times 2 = 10$
 $10 - 4 = 6$
 $6 \div 2 = 3$
 $3 + 4 = 7$
 He spent \$7

8) $180 - (28 + 28) = 124$ ($\angle ABC$)
 $180 - 92 = 88$ ($\angle ADB$)
 $180 - 88 = 92$ ($\angle BDC$)
 $180 - (92 + 28) = 60$ ($\angle DBC$)
 $124 - 60 = 64$ ($\angle ADB$)
 $180 - 64 = 116$
 $116 \div 2 = 58$ ($\angle ABE$)
 $58 - 28 = 30$ ($\angle EAD$)
 $\angle EAD$ is 30°

9) 20:21

10) $6.15 \times 100 = 615$
 $615 \div 20.5 = 30$
 She took 30 steps

11) $1.24 \times 3 = 3.72$
 $3.72 + 1.16 = 4.88$
 $488 \div 4 = 1.22$
 The average is 1.22m

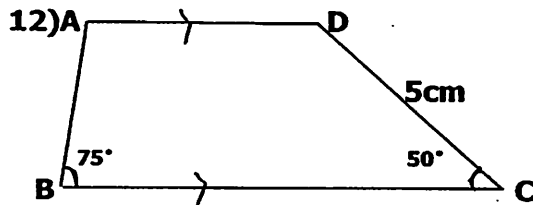

13) a) $180 - 110 = 70$
 $180 - 70 = 110$
 $180 - (70 + 72) = 88^\circ$
 $\angle HFJ$ is 88°
 b) $180 - 110 = 70$
 $70 \div 2 = 35^\circ$
 $\angle GHJ$ is 35°

14) a) $16 \times 2 = 32$
 $58 - 32 = 26$
 $26 \div 2 = 13$
 $16 \times 13 = 208$
 The area is 208cm^2
 b) $28 \times 13 \times 10 = 3640$
 $3640 - 1760 = 1880$
 $1880 \div 1000 = 1.880\text{L}$
 1.880L more must be poured in.

15) $2 \times 6 = 12$
 a) There will be 12 squares
 $40 - 2 = 38$
 $38 \div 2 = 19$
 b) There will be 19 dots

pattern no.	no. of squares	no. of dots
15	32	15
$16 \times 2 = 32$		
$32 + 15 = 47$		

c) The total number is 47

16) $50 - 13 = 37$

$37 \times 4 = 148$

a) Devi has \$148 at first

$37 \times 3 = 111$

$111 + 17 = 128$

$128 + 111 = 239$

b) Both of them have \$239 left.

17) a) $8: 7: 13$

b) $8u - 7u = 1u$

$1u \rightarrow 35$

$8u + 7u + 13u = 28u$

$28u \rightarrow \$980$

18) $1u$ of R $\rightarrow 2850$

$2850 \times 4 = 11460$

$6u \rightarrow 11400$

$11400 \div 6 = 1900$

$1u \rightarrow 1900$

$1900 \times 10 = 19000$

$10u \rightarrow 19000$

a) \$19000 at first

$19000 \times 30\% = 5700$

b) The school receive \$5700

$5700 + 19000 = 24700$

$1u \rightarrow 24700 \div 10 = 2470$

$6u \rightarrow 2470 \times 6 = 14820$

$4u$ of R $\rightarrow 14820 \div 4 = 3705$

$3u$ of R $\rightarrow 3705 \times 3 = 11115$

c) \$11115 in the end