



NANYANG PRIMARY SCHOOL

**SECOND SEMESTRAL EXAMINATION
2011**

**PRIMARY 5
MATHEMATICS**

PAPER 1

DURATION: 50 MINUTES

Booklet A	/ 20
Booklet B	/ 20

Paper 1 Total: / 40

Name: _____ ()

Class: Primary 5 ()

Date: 1 November 2011

Parent's Signature: _____

DO NOT OPEN THIS BOOKLET UNTIL YOU ARE TOLD TO DO SO.

FOLLOW ALL INSTRUCTIONS CAREFULLY.

ANSWER ALL QUESTIONS.

YOU ARE NOT ALLOWED TO USE A CALCULATOR.

PAPER 1 (BOOKLET A)

Questions 1 to 10 carry 1 mark each. Questions 11 to 15 carry 2 marks each. For each question, four options are given. One of them is the correct answer. Make your choice (1, 2, 3 or 4). Shade the oval (1, 2, 3 or 4) on the Optical Answer Sheet.

(20 marks)

1 Find the value of $100 - 24 + 4 \times 3 \div 2$.

(1) 120

(2) 82

(3) 70

(4) 44

2 Find the value of $\frac{7}{5} \times \frac{5}{9}$

(1) $\frac{6}{7}$

(2) $\frac{7}{9}$

(3) $\frac{25}{63}$

(4) $\frac{4}{5}$

- 3 A piece of wood measuring $\frac{5}{8}$ m is cut into 4 pieces of equal length.
What is the length of each piece of wood?

(1) 1 m

(2) $\frac{1}{2}$ m

(3) $\frac{5}{32}$ m

(4) $2\frac{1}{2}$ m

- 4 Round off 3.897 to 2 decimal places.

(1) 3.80

(2) 3.89

(3) 3.90

(4) 4.00

- 5 In the figure below, AD is perpendicular to BD and CE is perpendicular to AB. AEB and BCD are straight lines. Which of the following lines are bases of Triangle ABC if CE and AD are the heights respectively?

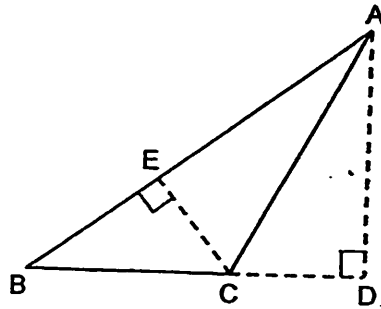

- (1) AC and BC
 (2) AB and BC
 (3) AB and BD
 (4) CD and AB
- 6 Find the missing number in the box.

$$28 : 12 : 60 = 14 : \boxed{?} : 30$$

- (1) 7
 (2) 2
 (3) 3
 (4) 6

7 The total cost of 3 pair of jeans was \$564.12. What was the average cost of each pair of jeans?

(1) \$188.04

(2) \$188.40

(3) \$1582.36

(4) \$1692.36

8 There were 150 people at a party and 30 of them brought presents. What percentage of the people brought presents?

(1) 20 %

(2) 30 %

(3) 45 %

(4) 80 %

- 9 The figure below shows Triangle WXY which is not drawn to scale. $\angle WYX$ is 76° and $\angle WXY$ is 46° . Which of the following statements is true about Triangle WXY?

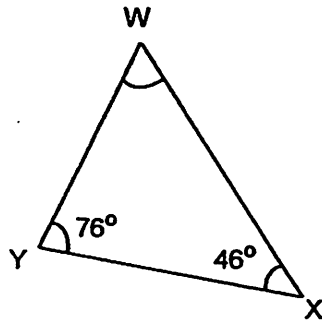

- (1) The sum of $\angle WXY$ and $\angle YWX$ is 90° .
- (2) Line WY and line XY are equal.
- (3) None of the angles in Triangle WXY is equal.
- (4) Triangle WXY is an equilateral triangle.
- 10 The following figures are not drawn to scale. Which of the figures below is/are parallelogram(s)?

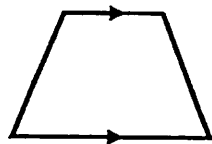

(A)

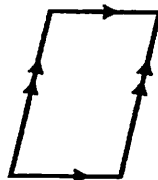

(B)

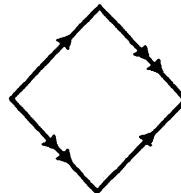

(C)

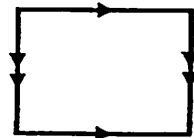

(D)

- (1) A only
- (2) B only
- (3) B and C only
- (4) B, C and D only

- 11 The area of the shaded part of the cube shown below is 9 cm^2 .
Find the volume of the cube.

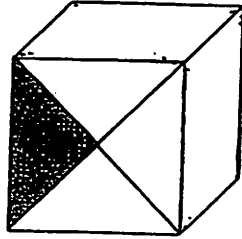

- (1) 27 cm^3
- (2) 81 cm^3
- (3) 216 cm^3
- (4) 729 cm^3
- 12 Mr Goh had some badminton rackets. On Monday, he sold 0.25 of them. He sold 20 fewer badminton rackets on Tuesday than on Monday. If he had 160 badminton rackets left, how many badminton rackets did he have at first?
- (1) 240
- (2) 280
- (3) 320
- (4) 360

13 A total of 490 children were in a music school. If there were 250 more boys than girls, find the ratio of the number of girls to the total number of children in the music school.

(1) 12 : 49

(2) 24 : 49

(3) 25 : 49

(4) 37 : 49

14 The length of a cuboid is 8 cm. Its breadth is $\frac{5}{8}$ of its length. The ratio of its breadth to its height is 1 : 2. What is the volume of the cuboid?

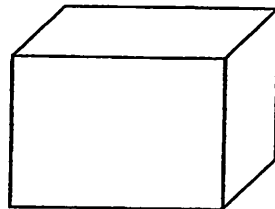

(1) 400 cm³

(2) 320 cm³

(3) 80 cm³

(4) 40 cm³

15 60% of the people who went to a concert were adults. The ratio of the number of boys to the number of girls who went to the concert was 2 : 3. What percentage of the number of people who went to the concert were girls?

- (1) 24%
- (2) 30%
- (3) 36%
- (4) 40%

Name: _____ () Class: Pr 5 ()

P5 SA2 2011

PAPER 1 (BOOKLET B)

Questions 16 to 25 carry 1 mark each. Write your answers in the spaces provided. For questions which require units, give your answers in the units stated.

(10 marks)

16 Find the value of $96\ 500 \div 50$.

Ans: _____

17 Find the value of $1 - \frac{1}{3} - \frac{1}{6}$. Express your answer in its simplest form.

Ans: _____

18 Express 40 kg 67 g in kilograms.

Ans: _____ kg

19 What is the ratio of 5 minutes to 1 hour in its simplest form?

Ans: _____

20 The average time John took to complete 2 similar jigsaw puzzles was 5 weeks 6 days. He took 2 weeks 3 days to complete the third puzzle. What was the average time he took to complete the 3 jigsaw puzzles? Express your answer in weeks and days.

Ans: _____ weeks _____ days

21 What is the volume of the cuboid below?

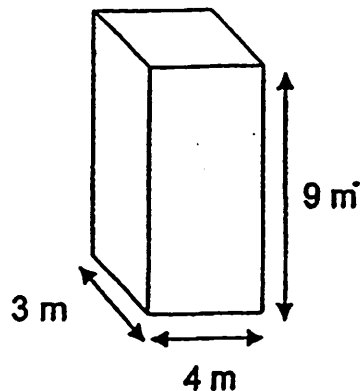

Ans: _____ m³

22 Express 0.32 as a percentage.

Ans: _____%

23 In the figure below, ST, UV and WX are straight lines.
 $\angle SXV = 102^\circ$ and $\angle UXW = 39^\circ$.
Find $\angle WXT$.

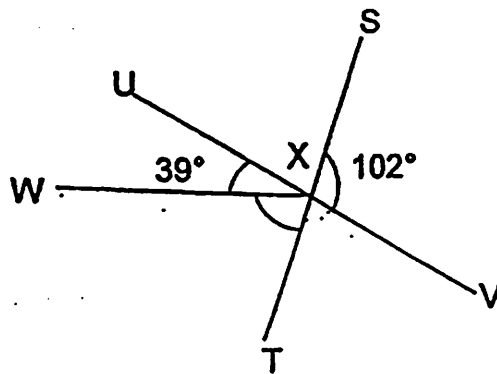

Ans: _____°

- 24 The figure below is not drawn to scale. PQR is an equilateral triangle. SRQ is a straight line. $\angle PSR = 27^\circ$. Find $\angle SPR$.

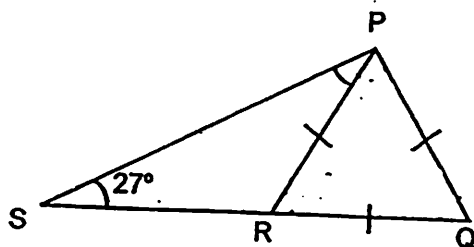

Ans: _____^o

- 25 The figure below is not drawn to scale. PQRS is a rhombus. Find $\angle y$.

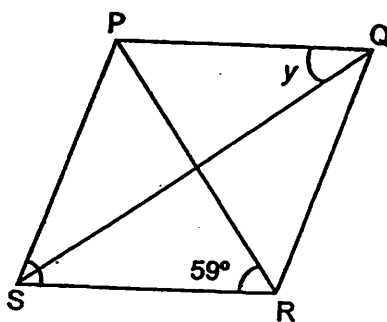

Ans: _____^o

Questions 26 to 30 carry 2 marks each. Show your working clearly in the space provided for each question and write your answers in the spaces provided. For questions which require units, give your answers in the units stated.

(10 marks)

- 26 The breadth of a playground is $2\frac{1}{4}$ m. Its length is 4 times as long as its breadth. What is the perimeter of the playground?

Ans: _____ m

- 27 Samy and Raju shared some berries in the ratio 8 : 11. When Samy received 24 berries from Raju, the new ratio of Samy's berries to Raju's berries became 12 : 7. How many berries did Samy have at first?

Ans: _____

- 28 The solid below is made up of cubes of edge 3 cm. How many cubes must be added to form a cuboid 21 cm by 15 cm by 6 cm?

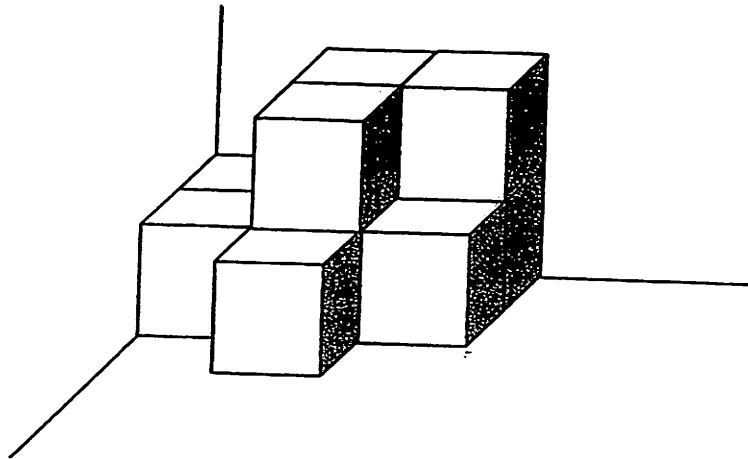

Ans: _____

- 29 Wenxi uses the four letters M, N, O and P to form a pattern. Which letter is in the 67th position?

M N O P P O N M M N O P P O N M ?
 1st 8th 16th 67th

Ans: _____

- 30 Fill in the boxes below with different operations (+, -, ×, ÷) to make the mathematical statement correct. Each operation is used once only.

$$24 \quad \boxed{} \quad (6 + 6) \quad \boxed{} \quad 6 = 22$$



NANYANG PRIMARY SCHOOL

**SECOND SEMESTRAL EXAMINATION
2011**

PRIMARY 5

MATHEMATICS

PAPER 2

DURATION: 1 HOUR 40 MINUTES

Paper 2 Total	/ 60
----------------------	-------------

GRAND TOTAL	/ 100
--------------------	--------------

Name: _____ ()

Class: Primary 5 ()

Date: 1 November 2011

Parent's Signature: _____

DO NOT OPEN THIS BOOKLET UNTIL YOU ARE TOLD TO DO SO.

FOLLOW ALL INSTRUCTIONS CAREFULLY.

ANSWER ALL QUESTIONS.

YOU ARE ALLOWED TO USE A CALCULATOR.

PAPER 2

Questions 1 to 5 carry 2 marks each. Show your working clearly in the space provided for each question and write your answers in the spaces provided. For questions which require units, give your answers in the units stated.

(10 marks)

-
- 1 A pen and a book cost \$28. Arif paid \$130 for 3 such pens and 5 such books. Find the cost of each book.

Ans: \$ _____

-
- 2 Mrs Ong bought $4\frac{11}{12}$ kg of meat. Her sister bought $2\frac{1}{6}$ kg less meat than her. How many kilograms of meat did they buy altogether?

Ans: _____ kg

- 3 The ratio of the area of Rectangle A to the shaded part is 5 : 3. The ratio of the area of Rectangle B to the shaded part is 7 : 2. If the area of Rectangle A is 16 cm^2 , find the area of the unshaded part of Rectangle B.

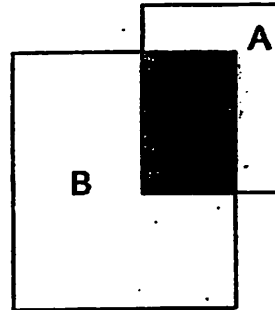

Ans: _____ cm^2

- 4 In the figure below, BE and CD are straight lines. $\angle BED = 42^\circ$ and $\angle BEF$ is twice of $\angle FEC$. Find $\angle BEF$.

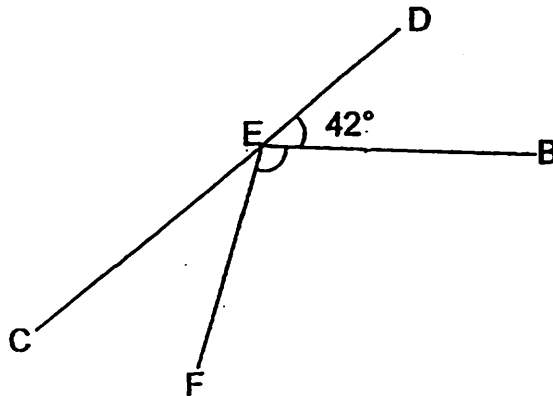

Ans: _____ $^\circ$

- 5 ABCD is a rhombus in which $\angle BAD$ is 120° . Line AB has been drawn for you in the space provided below. Draw rhombus ABCD by completing the figure.

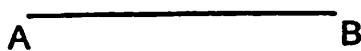

75

For questions 6 to 18, show your working clearly in the space provided for each question and write your answers in the spaces provided.

The number of marks available is shown in brackets [] at the end of each question or part-question.

(50 marks)

6 Harry spent $\frac{2}{3}$ of his money on some muffins and $\frac{3}{4}$ of the remaining money on some doughnuts.

(a) What fraction of his money did he spend on doughnuts?

(b) If he was left with \$5, how much money did Harry have at first?

Ans: (a) _____ [1]

(b) _____ [2]

- 7 A rectangular tank with a base area of 7150 cm^2 was partly filled with water to a height of 19 cm. When 84.37 litres of water was removed from the tank, the volume of water left in the tank was 20% of the capacity of the tank. What was the capacity of the tank?

Ans: _____ [3]

- 8 Mr Lee sold a computer to Mr Ang at a discounted price of \$1498. This amount included 7% GST. Mr Ang was given a 30% discount for the computer.

(a) How much was the GST?

(b) What was the usual price of the computer excluding 7% GST?

Ans: (a) _____ [1]

(b) _____ [2]

- 9 The figure below is not drawn to scale. ABC is an equilateral triangle. EC and BD are straight lines. $\angle ACE = 22^\circ$ and $\angle ABD = 36^\circ$. Find $\angle DFE$.

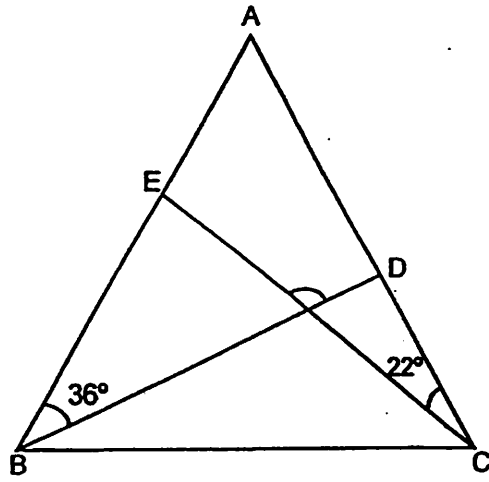

Ans: _____ [3]

- 10 The number of chairs in the hall is between 60 and 120. The chairs are arranged in a fixed number of rows. If 14 chairs are arranged in each row, there will be an excess of 8 chairs. However, if 16 chairs are arranged in a row, there will be a shortage of 6 chairs. Find the number of rows of chairs in the hall.

Ans: _____ [3]

- 11 Johan and Edward had a total of \$360. If Johan gave $\frac{2}{5}$ of his share to Edward, and Edward gave Johan $\frac{3}{7}$ of the amount of money he had after receiving the money from Johan, each of them would have an equal amount of money. How much money did Edward have at first?

Ans: _____ [4]

- 12 In the figure below, ABCD and DEFG are squares and XEC is a triangle. Square ABCD has a length of 6 cm while Square DEFG has a length of 2 cm. XFG is a straight line. Find the area of Triangle XEC.

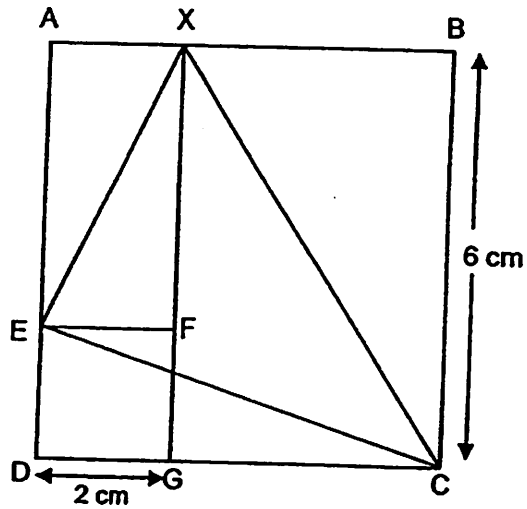

Ans: _____ [4]

13 In the figure below, PQRS is a parallelogram. PST and QUT are straight lines. $PU = QU$, $\angle QUP = 90^\circ$ and $\angle QRS = 80^\circ$. Find the value of

(a) $\angle x$

(b) $\angle y$

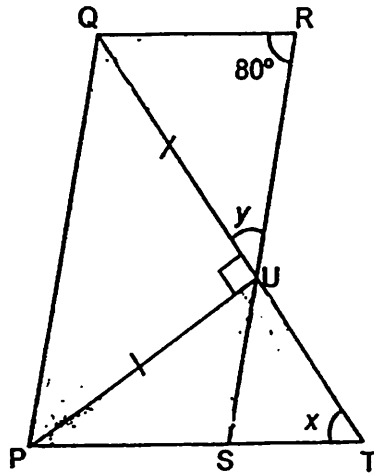

Ans: (a) _____ [3]

(b) _____ [1]

- 14 Jiemin, Ramlah and Ali had a total of 420 marbles. The ratio of the number of marbles that Ramlah had to the number of marbles that Ali had was 5 : 6 at first. After Jiemin and Ramlah each lost 50% of their marbles, the three children had 312 marbles left. How many marbles did Jiemin have at first?

Ans: _____ [4]

- 15 Sarah, Ben and Fatimah bought a present for their friend. The average amount paid by Sarah and Ben was \$94. The average amount paid by Sarah and Fatimah was \$123. Given that the ratio of the amount of money paid by Fatimah to the amount of money paid by Ben was 3 : 1, find the cost of the present.

Ans: _____ [4]

- 16 Mr Chen bought some pencil cases and bags for the children at a gathering. The price of each pencil case was \$2.40 while the price of each bag was \$10.80. For every 4 bags bought, he was given one such pencil case for free. After receiving the free pencil cases, the number of pencil cases was $\frac{1}{3}$ of the number of bags bought.

If Mr Chen paid a total of \$1584, how much more did he pay for the bags than the pencil cases?

Ans: _____ [5]

17 At first, the ratio of the number of men to the number of women in a cinema was 2 : 5. When 48 women and some men entered the cinema, the number of women increased by 12% and the total number of people in the cinema increased by 20%.

(a) How many men were there at first?

(b) What percentage of the people in the cinema were men in the end?
Express your answer as a mixed number.

Ans: (a) _____ [2]

(b) _____ [3]

- 18 Mrs Lim baked some tarts. She packed all the tarts in either small or big boxes. She packed 7 tarts in each small box and 10 tarts in each big box. At first, there were 4 times as many small boxes as the big boxes. After selling half of the number of small boxes of tarts and some big boxes of tarts, Mrs Lim gave her friends another 8 small boxes of tarts. The number of tarts in the unsold small boxes was thrice the number of tarts in the unsold big boxes. There were 280 tarts left in the big and small boxes. How many tarts did Mrs Lim bake at first?

Ans: _____ [5]

End of Paper

ANSWER SHEET

EXAM PAPER 2011

SCHOOL : NANYANG
SUBJECT : PRIMARY 5 MATHEMATICS

TERM : SA2

Q1	Q2	Q3	Q4	Q5	Q6	Q7	Q8	Q9	Q10	Q11	Q12	Q13	Q14	Q15
2	2	3	3	2	4	1	1	3	3	3	4	1	1	1

- 16) 1930 17) $\frac{1}{2}$ 18) 40.067kg 19) 1:12 20) 4 weeks 5 days
 21) 108m³ 22) 32% 23) 63° 24) 33° 25) 31°
 26) 22 $\frac{1}{2}$ m 27) 48 berries 28) 60 29) 0 30) -, ÷

Paper 2

1) $P + B = \$28$

$P \times 3 + B \times 5 = \130

$\$28 \times 3 = \84

$\$130 - \$84 = \$46$

$\$46 \rightarrow P \times 3 + B \times 3$

$2B \rightarrow \$46 \div 2 = \23

2) $2\frac{1}{6}\text{kg} \rightarrow 2\frac{2}{12}\text{kg}$

$4\frac{11}{12}\text{kg} - 2\frac{2}{12}\text{kg} = 2\frac{9}{12}\text{kg}$

$4\frac{11}{12}\text{kg} + 2\frac{9}{12}\text{kg} = 7\frac{2}{3}\text{kg}$

3) $16 \div 5 \times 3 = 9.6$

$9.6 \div 2 \times 5 = 24\text{cm}^2$

4) $180^\circ - 42^\circ = 138^\circ$

$138^\circ \div 3 = 46^\circ$

$46^\circ \times 2 = 92^\circ$

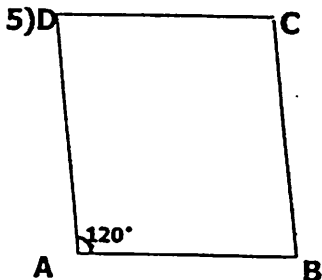

6) $\frac{3}{3} - \frac{2}{3} = \frac{1}{3}$

$\frac{1}{3} \times \frac{3}{4} = \frac{1}{4}$

$\frac{2}{3} \rightarrow \frac{8}{12}$

$\frac{1}{4} \rightarrow \frac{3}{12}$

$\frac{1}{3} \rightarrow \frac{4}{12}$

$\frac{4}{12} - \frac{3}{12} = \frac{1}{12}$

$\frac{1}{12} \rightarrow \5

$\frac{12}{12} \rightarrow \$5 \times 12 = \$60$

a) $\frac{1}{4}$

b) \$60

7) $7150\text{cm}^2 \times 19\text{cm} = 135850\text{cm}^3 = 135.85\text{L}$

$135.85\text{L} - 84.37\text{L} = 51.48\text{L} = 51480\text{cm}^3$

$51480\text{cm}^3 \rightarrow 20\%$

$100\% \rightarrow 51480\text{cm}^3 \times 5 = 257400\text{cm}^3$

8) \$1498 → 107%

1% → \$14

\$14 × 7 = \$98 (7%)

\$1498 - \$98 = \$1400 (70%)

1% → \$1400 ÷ 70% = \$20

100% → \$20 × 100% = \$2000

a) \$98

b) \$2000

10) 8 + 6 = 14

16 - 14 = 2

14 ÷ 2 = 7

12) $\frac{1}{2} \times 6 \times 2 = 6$

6 - 2 = 4

$\frac{1}{2} \times 4 \times 2 = 4$

$\frac{1}{2} \times 6 \times 4 = 12$

6 × 6 = 36

36 - 6 - 4 - 12 = 14 cm²

14) 312 - 108 = 204

10 → 204 ÷ 12 = 17

17 × 22 = 374

420 - 374 = 46

16) \$1526.40

17) a) 12% → 48

1% → 48 / 12 = 4

100% → 400

5u → 400

1u → 400 / 5 = 80

2u → 80 × 2 = 160

b) 400 + 160 = 560

100% → 560

120% → 560 / 100 × 120 = 672

672 - 560 - 48 = 64

64 + 160 = 224

224 / 672 × 100% = 33 $\frac{1}{3}$ %

9) 180° ÷ 3 = 60°

60° - 36° = 24°

60° - 22° = 38°

180° - (24° + 38°) = 118°

11) \$360 ÷ 2 = \$180

\$180 → 4u

1u → \$45

\$45 → 3p

1p → \$15

E → \$45 × 7 = \$315

2p → \$15 × 2 = \$30

\$315 - \$30 = \$285

13) 180° - 80° = 100°

180° - 90° = 90°

90° ÷ 2 = 45

100° - 45° = 55°

∠y → 180° - 55° - 80° = 45°

80° - 45° = 35°

180° - 45° - 90° = 45°

45° × 2 = 90°

∠x → 180° - 90° - 35° = 55°

a) ∠x = 55°

b) ∠y = 45°

15) \$94 × 2 = \$188 (S+B)

\$123 × 2 = \$246 (S+F)

(S+F) - (S+B) = Difference in F and B

\$246 - \$188 = \$58

3u - 1u = 2u

2u → \$58

1u → \$29

F → \$29 × 3 = \$87

\$188 + \$87 = \$275

18) 722

END

91