

Math Teacher:



**RAFFLES GIRLS' PRIMARY SCHOOL
SEMESTRAL ASSESSMENT 2
MATHEMATICS (PAPER 1)
PRIMARY 5**

Name: _____ ()

Form Class: P5 _____

Date: 24 October 2011

Duration: 50 min

Your Score (Out of 100 marks)			
Your Score (Out of 40 marks)			
		Banded Math Class	Level
PAPER 1 (40%)	Highest Score		
	Average Score		
TOTAL (100%)	Highest		
	Average Score		
Parent's Signature			

INSTRUCTIONS TO CANDIDATES

1. Do not turn over this page until you are told to do so.
2. Follow all instructions carefully.
3. Answer **ALL** questions and show all working clearly.
4. **NO** calculator is allowed for this paper.

SECTION A (20 marks)

Questions 1 to 10 carry 1 mark each. Question 11 to 15 carry 2 marks each. For each question, four options are given. One of them is the correct answer. Make your choice (1, 2, 3 or 4). Shade your answer (1, 2, 3 or 4) on the OAS provided. All diagrams are not drawn to scale.

1. 3 tens, 4 ones and 5 tenths is _____.

- (1) 34.05
- (2) 34.50
- (3) 43.05
- (4) 43.50

()

2. Find the value of $\frac{3}{4} + 1\frac{1}{3}$.

- (1) $1\frac{1}{12}$
- (2) $1\frac{4}{7}$
- (3) $2\frac{1}{12}$
- (4) $2\frac{4}{7}$

()

3. Find the area of the shaded figure.

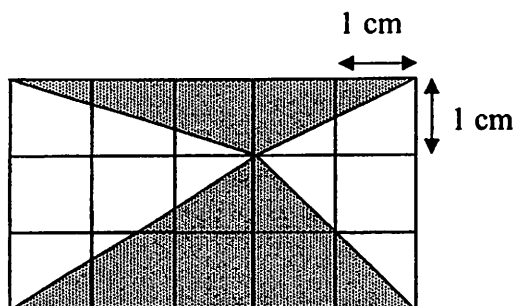

- (1) 5.5 cm^2
- (2) 7.5 cm^2
- (3) 10 cm^2
- (4) 15 cm^2

()

4. There are 5 points, A, B, C, D and Y, on the square-grid shown below. Which point is east of point Y?

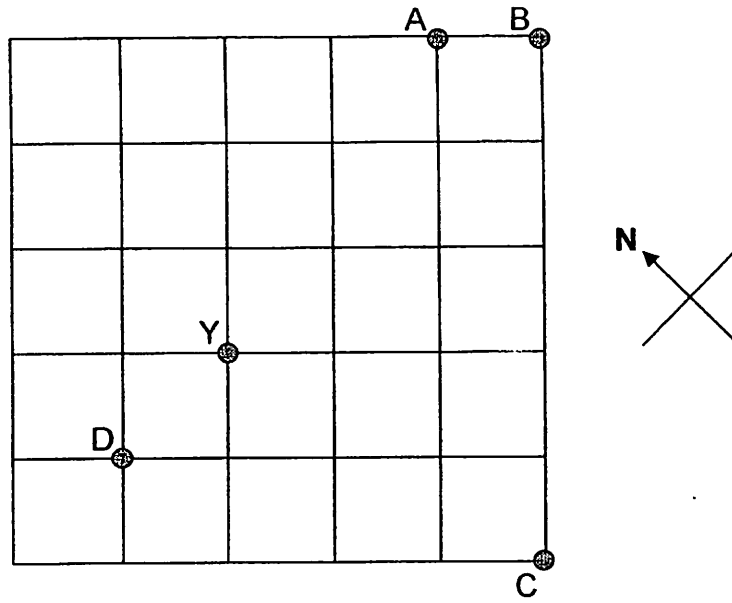

- (1) A
- (2) B
- (3) C
- (4) D

()

5. Which of the following **cannot** be tessellated?

- (1)
- (2)
- (3)
- (4)

()

6. Find the value of the following.

$$(106 - 6 \times 4) + 18 \div 2$$

- (1) 50
(2) 91
(3) 209
(4) 409

()

7. The table below showed the number of tourists in Singapore.

Year	Tourists from China	Total Number of Tourists
2008	800	4000
2009	1800	5000

What percentage of the tourists was from China in 2009?

- (1) 25%
(2) 36%
(3) 45%
(4) 64%

()

8. Express $1\frac{5}{9}$ as a decimal to 1 decimal place.

- (1) 0.5
(2) 0.6
(3) 1.5
(4) 1.6

()

9. The ratio of Ann's savings to Ben's savings is 2 : 3.
The ratio of Ben's savings to Carl's savings is also 2 : 3.
What is the ratio of Ann's savings to Carl's savings?

- (1) 2 : 3
(2) 3 : 2
(3) 4 : 9
(4) 9 : 4

()

10. Which number is a common factor of 30 and 45?

- (1) 6
- (2) 15
- (3) 30
- (4) 90

()

11. A rhombus has only _____ line(s) of symmetry.

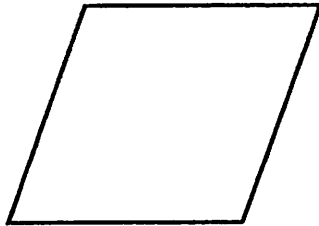

- (1) 1
- (2) 2
- (3) 0
- (4) 4

()

12. The diagram below is made up of a rectangle and a square.

The breadth of the rectangle is $\frac{2}{5}$ that of its length.

Find the area of the shaded region.

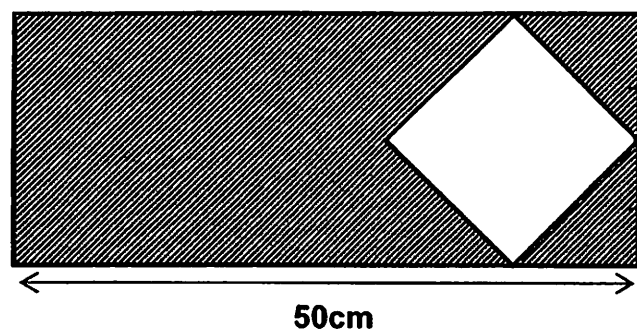

- (1) 200 cm²
- (2) 750 cm²
- (3) 800 cm²
- (4) 1000 cm²

()

13. John scored a total of 98 marks for his Mathematics and Science examinations. He scored 60 marks for English and 70 marks for Chinese. What was his average of the 4 subjects?

(1) 57.0

(2) 65.0

(3) 76.0

(4) 81.5

()

14. Penny and Queenie shared some stickers in the ratio 5 : 7. When Queenie gave 30 stickers to Penny, the ratio of Penny's stickers to Queenie's stickers became 5 : 1. How many stickers did Queenie have at first?

(1) 30

(2) 35

(3) 42

(4) 60

()

15. Yazid and his classmates raced one another across a field.

Midway through the race, $\frac{1}{5}$ of Yazid's classmates was running in

front of him and $\frac{7}{9}$ of the total number of pupils in the class was

running behind him. What was the total number of pupils in the class including Yazid?

(1) 35

(2) 36

(3) 38

(4) 45

()

SECTION B (20 marks)

Questions 16 to 25 carry 1 mark each. Write your answers in the spaces provided. For questions which require units, give your answers in the units stated. All diagrams are not drawn to scale unless otherwise stated.

16. Arrange these numbers in descending order.

0.206, 0.026, 0.602, 0.062

Ans: _____ , _____ , _____ , _____

17. A bag of corn flour weighed 0.42 kg.
Find the total mass of 70 such bags of corn flour.

Ans: _____ kg

18. $3 \frac{1}{A} = \frac{13 + A}{A}$

Find the value of A.

Ans: _____

19. 4 girls shared $\frac{6}{7}$ of a cake equally.
What fraction of the cake did each girl get?

Ans: _____

20. A tank was completely filled with water at 1 p.m..
To empty the tank, water was allowed to flow out at different rate.
The line graph below shows the volume of water in the tank from 1 p.m. to 4 p.m.

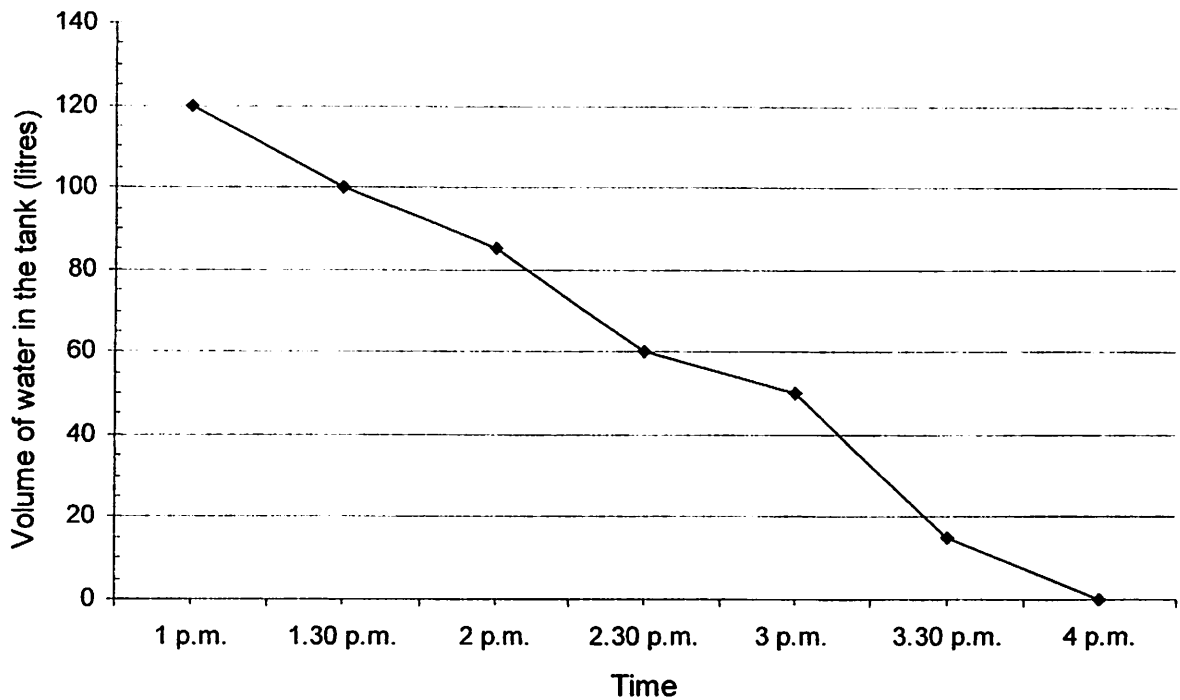

How long did it take for the tank to be half-emptied?

Ans: _____ h

21. ABC is an isosceles triangle and ACD is a straight line. Find $\angle q$.
(The figure is not drawn to scale.)

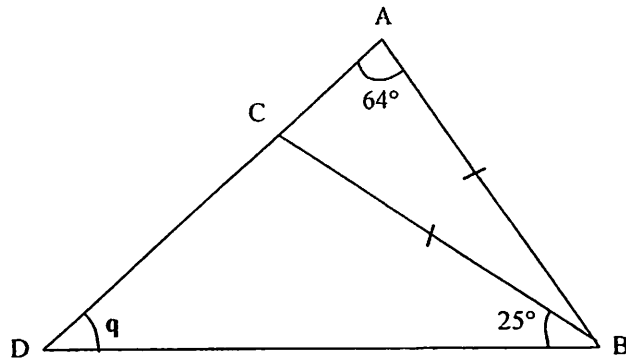

Ans: _____°

22. In the figure below, not drawn to scale, PQRT is a trapezium and RST is an equilateral triangle. Find $\angle PTS$.

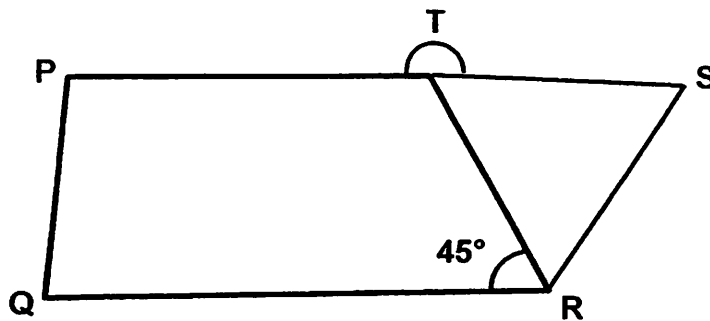

Ans: _____°

23. 8 girls take 3 days to paint a room.
How many girls are required to paint the same room in 1 day?

Ans: _____

24. Extend the tessellation by drawing 2 more unit shapes.

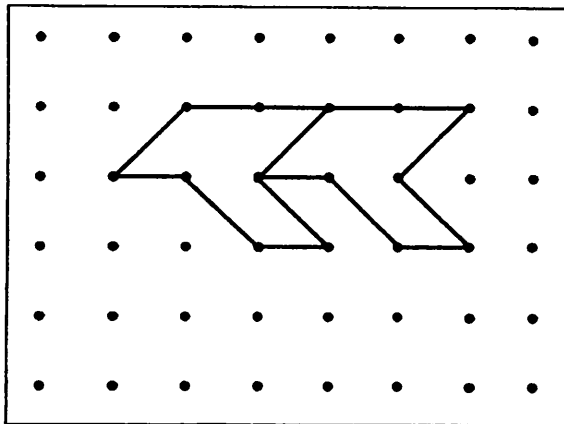

25. In a class of 36 pupils, 12 of them do not wear glasses.
What percentage of the pupils wear glasses?

Ans: _____ %

Questions 26 to 30 carry 2 marks each. Show your working clearly in the space provided for each question and write your answers in the space provided. For questions which require units, give your answers in the units stated. All diagrams are not drawn to scale unless otherwise stated. Answers in fractions or ratio must be expressed in the simplest form.

26. The figure below is made up of 5 identical rectangles. What is the minimum number of such rectangle(s) that must be added to the figure to form a square?

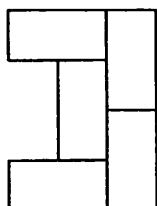

Ans: _____

27. Study the number line below. Find the difference between value A and value B.

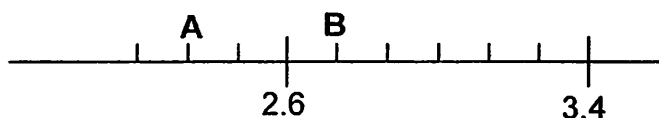

Ans: _____

28. A tank measuring 20cm by 40cm by 15cm is $\frac{3}{5}$ full of water.
Find the amount of water needed to fill the tank completely.

Ans: _____ l

29. The diagram below shows a shaded triangle ABC within the square grids.
Using BC as the base, draw another triangle within the grid that has **HALF** the area as triangle ABC.

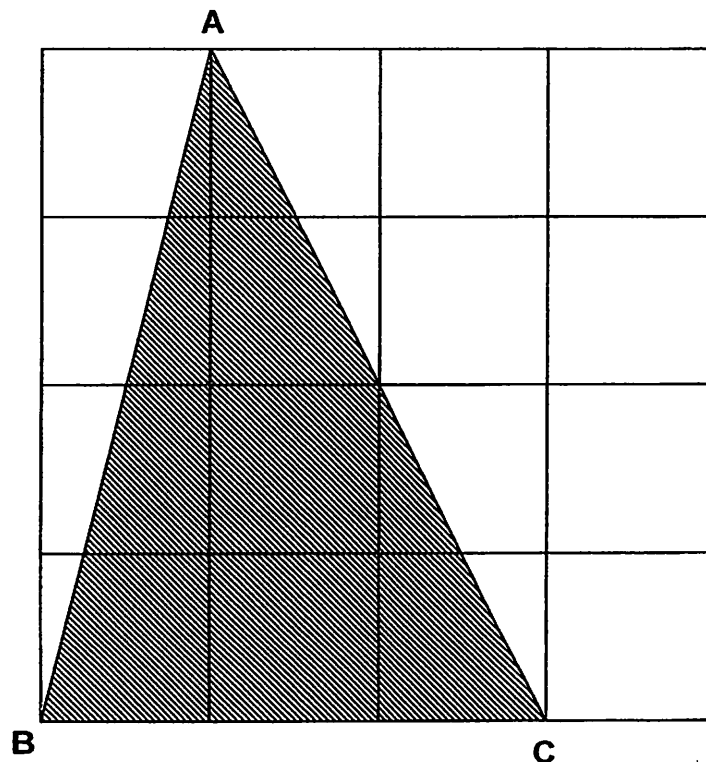

30. There were 5 rounds in a Math Challenge.
The graph below shows the points obtained by Gary and Peter in 4 of the rounds.

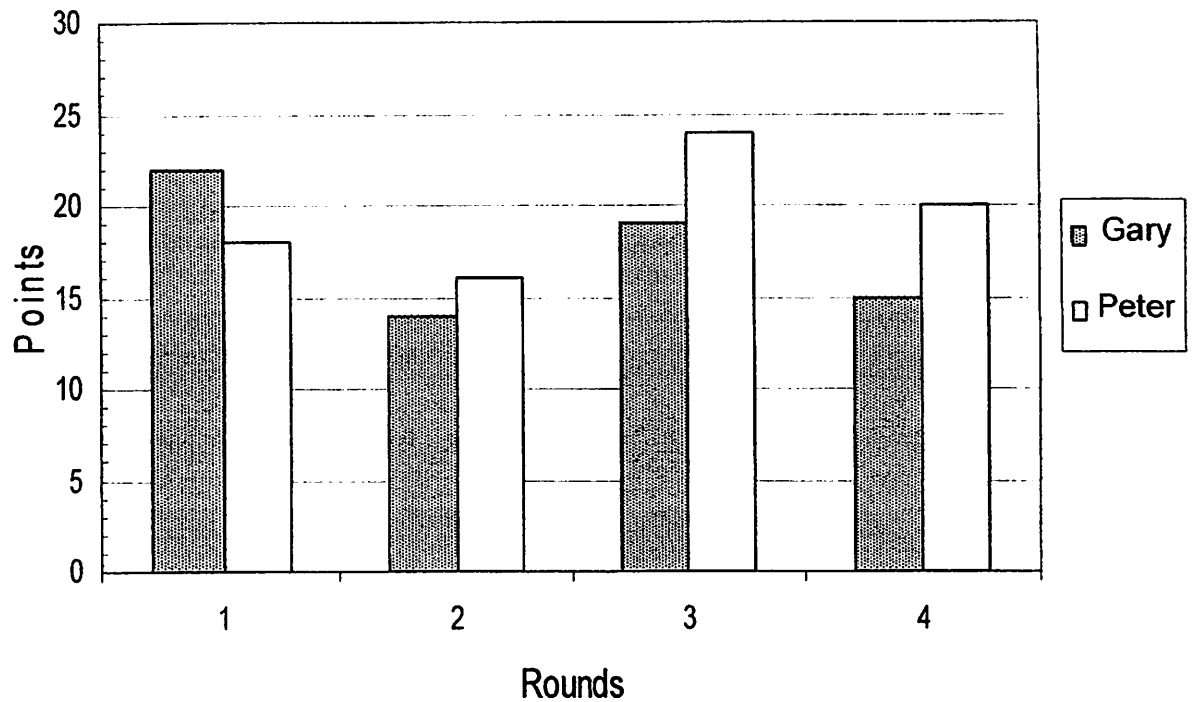

There can only be one winner in the Math Challenge.
If Gary obtained 24 points in Round 5, what is the minimum number of points Peter must obtain in order to win the Math Challenge?

Ans: _____

Math Teacher:



**RAFFLES GIRLS' PRIMARY SCHOOL
SEMESTRAL ASSESSMENT 2
MATHEMATICS (PAPER 2)
PRIMARY 5**

Name: _____ ()

Form class: P5 _____

Date: 24 October 2011

Duration: 1 h 40 min

Your Score (Out of 60 marks)		
	Banded Math Class	Level
Highest Score		
Average Score		

INSTRUCTIONS TO CANDIDATES

1. Do not turn over this page until you are told to do so.
2. Follow all instructions carefully.
3. Answer **ALL** questions and show all working clearly.
4. The use of calculator is allowed for this paper.

Questions 1 to 5 carry 2 marks each. Show your working clearly in the space provided for each question and write your answers in the spaces provided. For questions which require units, give your answers in the units stated. All diagrams are not drawn to scale unless otherwise stated. (10 marks)

1. The figure below is not drawn to scale. ABCD is a parallelogram. CDE and GDF are straight lines. Find $\angle DFE$.

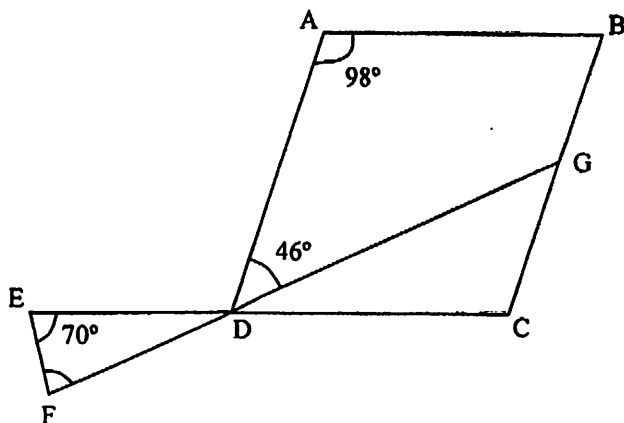

Ans: _____° [2]

2. In the figure below, AB and GF are straight lines. $CD \parallel EF$. Find $\angle GFE$.

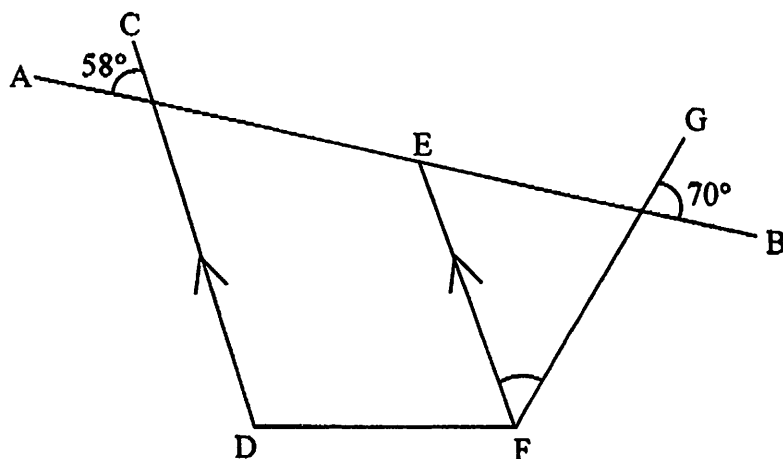

Ans: _____° [2]

3. There are 23 odd numbers between 49 and ☆.
 ☆ is an even number. What is ☆ ?

Ans: _____ [2]

4. PQ is one side of a right-angled isosceles triangle. Complete the diagram to form the isosceles triangle PQR where PQ = QR.

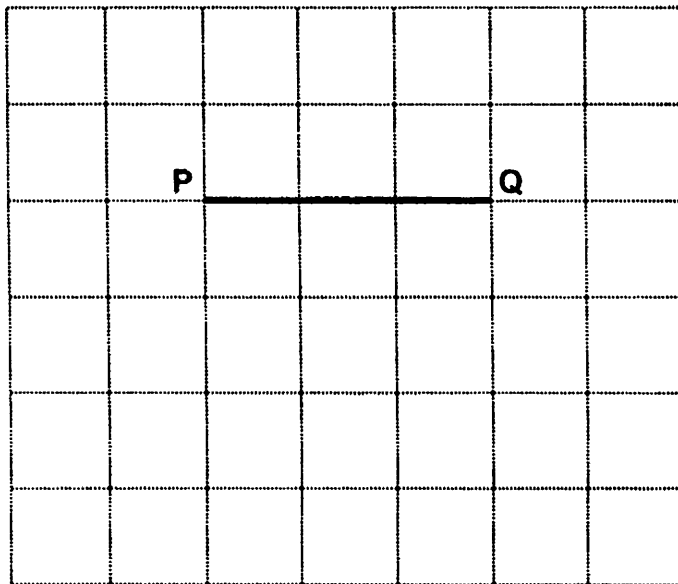

5. The diagram below shows two squares, A and B.
 The shaded area represents $\frac{1}{4}$ of square B and $\frac{4}{25}$ of square A.
 Given that the length of square B is 20 cm, find the area of square A.

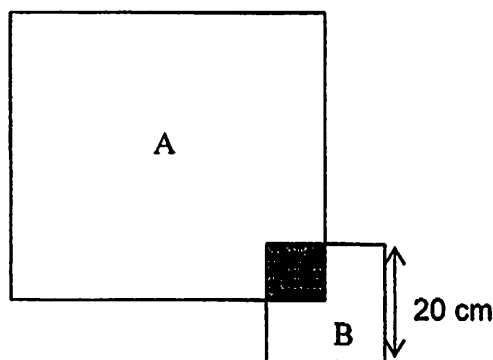

Ans: _____ cm² [2]

For questions 6 to 18, show your working clearly in the space provided for each question and write your answers in the spaces provided. All diagrams are not drawn to scale unless otherwise stated.

The number of marks available is shown in the brackets [] at the end of each question or part-question. (50 marks)

6. A pen cost \$1.10 less than a file.
 Karin can either buy 48 files or 92 pens with all her money.
 How much does a pen cost?

Ans: _____ [3]

7. In the figure below, not draw to scale, QRST is a parallelogram and PQTU is a trapezium.
 (a) Find $\angle x$
 (b) Find $\angle y$

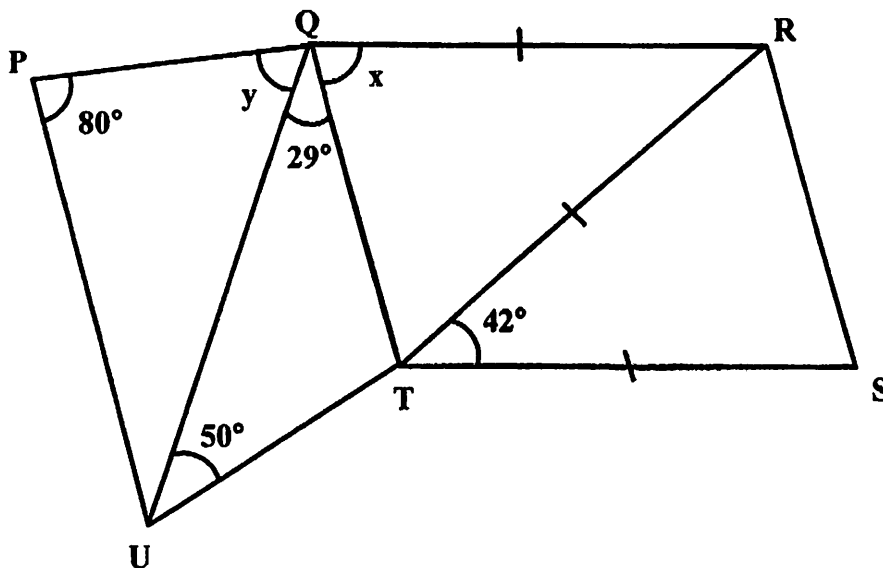

Ans: (a) _____ [1]

(b) _____ [2]

8. There are 22 boys and 18 girls in Primary 5A.
The average mass of all the boys is 41 kg and the average mass of all the girls is 38 kg. What is the average mass of all the pupils in Primary 5A?

Ans: _____ [3]

9. Ali and Maria each had an equal amount of money at first.
Every day, Ali spent \$25 and Maria spent \$18.
When Ali spent all his money, Maria still had \$357 left.
How much did each of them have at first?

Ans: _____ [3]

19

10. Sue had \$80 more than her brother. After Sue spent 25% of her money and her brother spent 75% of his money, they still had \$420 left altogether.
- (a) How much did Sue have left in the end?
 - (b) Express the amount of money her brother had left as a fraction of the amount of money Sue had in the end.
(Give your answer in the simplest form.)

Ans: (a) _____ [3]

(b) _____ [1]

11. On the first day, 116 flags were used to mark the total distance of a road race. The distance between each flag was 2.2 km. On the second day, some flags were removed and the remaining flags were used to mark the same total distance. The new distance between each flag was 2.75km. How many flags were removed?

Ans: _____ [3]

12. Figure 1 shows a rectangular container filled with some water and 8 identical blocks. The base area of the rectangular container is 448 cm^2 . Figure 2 shows the same container being turned upright. Find the volume of water in the container.

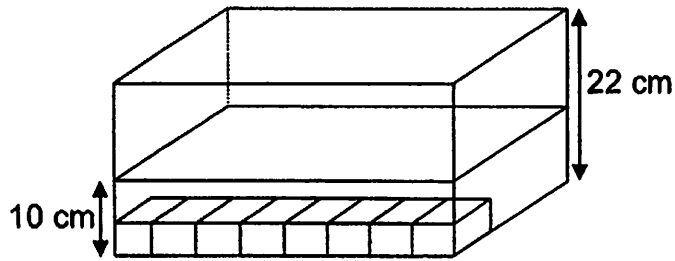

Figure 1

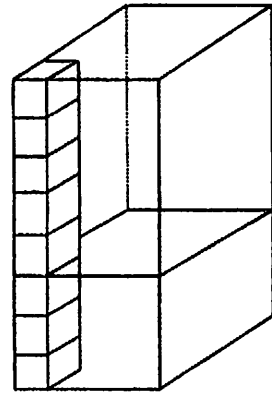

Figure 2

Ans: _____ [4]

21

13. Becky bought 7 basketballs with $\frac{3}{7}$ of the money she had.
She bought another 2 basketballs and 11 baseballs with her remaining money.
If Becky used the amount of money she had at first to buy only baseballs,
what was the maximum number of baseballs she could buy?

Ans: _____ [4]

14. Tom had a total of 430 two-dollar and five-dollar notes.
Jerry had 336 two-dollar notes and 220 five-dollar notes.
Jerry had \$396 more than Tom.
(a) How much did Tom have?
(b) How many two-dollar notes did Tom have?

Ans: (a) _____ [2]

(b) _____ [2]

15. The length of Rope A and Rope B is 30.55 m.
The length of Rope B, Rope C and Rope D is 58.93 m.
The length of Rope C, Rope D and Rope E is 64.53 m.
Rope E is twice the length of Rope A. Find the length of Rope A.
Express your answer in metres.

Ans: _____ [4]

23

16. The mass of sand in Sack B was $\frac{1}{4}$ the mass of sand in Sack A.
After 52.5 kg of the sand in Sack A and 10 kg 150 g of the sand in Sack B was used, the mass of sand in Sack A was $\frac{1}{2}$ the mass of sand in Sack B.
What was the total mass of sand in Sack A and Sack B at first?

Ans: _____ [5]

17. The ratio of the number of \$2 notes and \$5 notes Jamie had was 15 : 13.
She exchanged 60 pieces of \$2 notes for \$5 notes.
She then had an equal number of \$2 and \$5 notes.
What was the total value of \$2 and \$5 notes Jamie had?

Ans: _____ [5]

25

18. The average number of sit-ups performed by 15 girls and some boys was 50.
The average number of sit-ups performed by the girls was 80% of the average number of sit-ups performed by all the pupils.
The average number of sit-ups performed by the boys was 30% more than the average number of sit-ups performed by the girls.
- (a) What was the average number of sit-ups performed by the girls?
 - (b) What percentage of the pupils were boys?

Ans: (a) _____ [1]

(b) _____ [4]

ANSWER SHEET

EXAM PAPER 2011

SCHOOL : RAFFLES GIRLS'
SUBJECT : PRIMARY 5 MATHEMATICE

TERM : SA2

Q1	Q2	Q3	Q4	Q5	Q6	Q7	Q8	Q9	Q10	Q11	Q12	Q13	Q14	Q15
2	3	2	2	2	2	2	4	3	2	2	3	1	3	2

16) 0.602, 0.206, 0.062, 0.026

17) 29.4kg

18) 6

19) $1\frac{3}{4}$

20) 1.5h

21) 30°

22) 185°

23) 24 girls

24)

25) $66\frac{2}{3}\%$

26) 3 rectangle

27) 0.4

28) 48L

29)

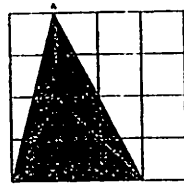

30) 17 points

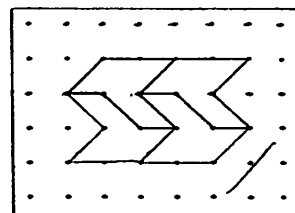

Paper 2

1) $\angle DAB \rightarrow \angle BCD = 98^\circ$

$180^\circ - 98^\circ = 82^\circ$

$\angle GDC \rightarrow 82^\circ - 46^\circ = 36^\circ$

$\angle GDC \rightarrow \angle EDF = 36^\circ$

$70^\circ + 36^\circ = 106^\circ$

$180^\circ - 106^\circ = 74^\circ (\angle DFE)$

2) $180^\circ - 58^\circ = 122^\circ$

$180^\circ - 122^\circ = 58^\circ$

$58^\circ + 70^\circ = 128^\circ$

$\angle GFE \rightarrow 180^\circ - 128^\circ = 52^\circ$

3) $23 \times 2 = 46$ (numbers)

$49 + 46 = 95$

$95 + 1 = 96$

5) $20 \times 20 = 400$

$400 \div 4 = 100$ ($\frac{1}{4}$ of B)

$100 \div 4 = 25$

$25 \times 25 = 625 \text{ cm}^2$

6) $92 - 48 = 44$

$\$1.10 \times 48 = \52.80

$\$52.80 \div 44 = \1.20

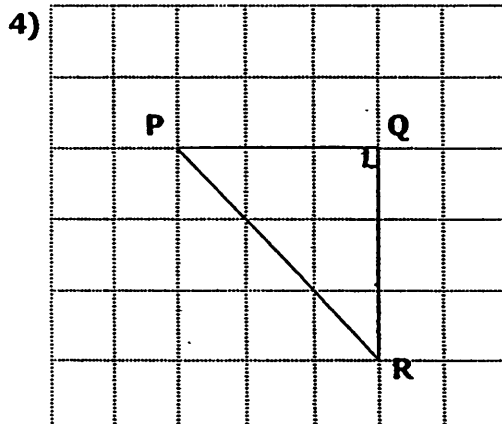

7)a) $180^\circ - 42^\circ = 138^\circ$
 $\angle TRS \rightarrow 138^\circ \div 2 = 69^\circ$
 $\angle QTR \rightarrow \angle TRS = 69^\circ$
 $\angle X \rightarrow 69^\circ$
 b) $\angle TQU \rightarrow \angle PUQ = 29^\circ$
 $29^\circ + 80^\circ = 109^\circ$
 $180^\circ - 109^\circ = 71^\circ$
 $\angle y \rightarrow 71^\circ$

8) $41 \times 22 = 902$
 $38 \times 18 = 684$
 $902 + 684 = 1586$
 $22 + 18 = 40$
 $1586 \div 40 = 39.65\text{kg}$

9) $\$25 - \$18 = \$7$
 $\$357 \div 7 = 51$
 $51 \times 25 = \$1275$
Check
 $51 \times \$18 = \918
 $\$918 + \$357 = \$1275$

10)a) $80 \div 4 = 20$
 $20 \times 3 = 60$
 $420 - 60 = 360$ (4u)
 $360 \div 4 = 90$
 $3 \times 90 = 270$
 $270 + 60 = \$330$
 b) $90/330 = 3/11$

11) $116 - 1 = 115$
 $115 \times 2.2 = 253$
 $253 \div 2.75 = 92$
 $92 + 1 = 93$
 $116 - 93 = 23$ flags

12) $448 \times 22 = 9856$ (cm²) (vol of container)
 $448 \times 10 = 4480$ (vol of water with blocks)
 $12 \times 448 = 5376$ (air space)cm³
 $448 \div 8 = 56$
 $8 - 3 = 5$
 $56 \times 5 = 280$
 $280 \times 22 = 6160$
 $6160 - 5376 = 784$
 $56 \times 3 = 168$
 $168 \times 22 = 3696$
 $448 - 3696 = 784$
 $784 \div 5 = 156.8$ (1 block)
 $156.8 \times 8 = 1254.4$
 $4480 - 1254.4 = 3225.6\text{cm}^3$

13) $2BB + 11\text{base} \rightarrow 4/7$
 $6BB + 33\text{base} \rightarrow 4/7 \times 3 = 12/7$
 $7BB + 0\text{base} \rightarrow 3/7$
 $42BB + 231\text{base} \rightarrow 12/7 \times 7$
 $= 84/7$
 $84 - 18 = 66$
 $231 \div 66 = 3.51$ (1unit)1 base
 $3.5 \times 7 = 24.5$
 $25 - 1 = 24$

15) $58.93\text{m} - 30.55\text{m} = 28.38\text{m}$ (Ropes A,C&D)
 $64.53\text{m} - 28.38\text{m} = 36.15\text{m}$ (A,E)
 $36.15\text{m} \div 3 = 12.05\text{m}$

14)a) $336 \times \$2 = \672
 $220 \times \$5 = \1100
 $\$1100 + \$672 = \$1772$ (J)
 $\$1772 - \$396 = \$1376$ (T)
 b) $430 \times 5 = 2150$
 $2150 - 1376 = 774$
 $\$5 - \$2 = \$3$
 $774 \div 3 = 258$ (\$2)

17) $60 + 24 = 84$
 $84 \div 2 = 42$ (1unit)
 $15 \times 42 = 630$
 $13 \times 42 = 546$
 $630 \times \$2 = \1260
 $546 \times \$5 = \2730
 $\$1260 + \$2730 = \$3990$

16) $4 \times 10.15 = 40.6$
 $52.5 - 40.6 = 11.9$
 $11.9 \div 7 = 1.7$
 $2 \times 1.7 + 10.15 = 13.55$
 $5 \times 13.55 = 67.75\text{kg}$

**18)a) $50 \div 100 = 0.5$
 $0.5 \times 80 = 40$ sit-ups
b) $40 \times 15 = 600$ (sit-ups by G)
 $40 \div 100 = 0.4$
 $0.4 \times 130 = 52$ (average of B)
 $75 \times 52 = 3900$
 $3900 + 600 = 4500$
 $4500 \div (75 + 15) = 50$
 $75 + 15 = 90$
 $75/90 \times 100\% = 83\frac{1}{3}\%$**