

--	--	--	--	--	--	--

Anglo-Chinese School (Junior)/
Anglo-Chinese School (Primary)



**COMBINED PRELIMINARY EXAMINATION (2011)
PRIMARY 6**

MATHEMATICS

**PAPER 1
Booklet A**

Wednesday

24 AUGUST 2011

50 min

INSTRUCTIONS TO PUPILS

1. Do not turn over this page until you are told to do so
2. Follow all instructions carefully.
3. Answer all questions.
4. Write your answers in this booklet.
5. You are **not** allowed to use a calculator.

Name : _____ ()

Class : 6.()

Parent's Signature: _____

This question paper consists of 8 printed pages. (Inclusive of cover page)

Questions 1 to 10 carry 1 mark each. Question 11 to 15 carry 2 marks each.
Make your choice (1, 2, 3 or 4). Shade the correct oval (1, 2, 3 or 4) on the
Optical Answer Sheet (OAS). (20 marks)

1. The digit 2 in ~~12~~6 450 is in the _____ place.
- 1) hundreds
 - 2) thousands
 - 3) ten thousands
 - 4) hundred thousands
2. Which one of the following numbers is the smallest?
- 1) 7.17
 - 2) 7.71
 - 3) 7.017
 - 4) 7.071
3. Tom is paid \$40 for working 8 hours. At this rate, how many hours must he work to earn \$480?
- 1) 12
 - 2) 60
 - 3) 96
 - 4) 160

4. 4 girls share 2 identical butter cakes equally.
5 boys share 4 identical butter cakes equally.
What is the difference between each boy's and each girl's share?

- 1) $\frac{1}{5}$
- 2) $\frac{1}{4}$
- 3) $\frac{3}{10}$
- 4) $\frac{1}{2}$

5. Cubes of the same size with edge 3-cm are stacked in the corner of a box as shown.

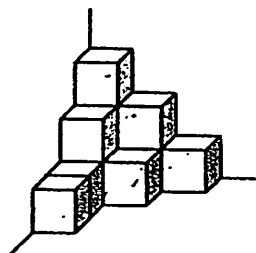

What is the volume of the figure?

- 1) 63 cm^3
- 2) 99 cm^3
- 3) 189 cm^3
- 4) 297 cm^3

6. Which figure below is a symmetric figure?

1)

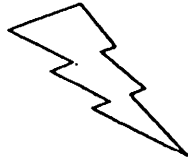

2)

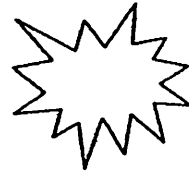

3)



4)

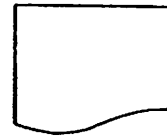

7. Jenny watched a concert which lasted 2h 15 min. The concert ended at 10.30 p.m. At what time did the concert begin?

1) 8.00 p.m.

2) 8.15 p.m.

3) 8.30 p.m.

4) 8.45 p.m.

8. A bookshop sold 3 pens for \$y. How much change did Mr Lee get if he paid the cashier \$100 for 27 pens?

- 1) $\$(100 + 9y)$
- 2) $\$(100 - 9y)$
- 3) $\$(100 + 81y)$
- 4) $\$(100 - 81y)$

9. The line graph below shows Gary's expenditure over five weeks.

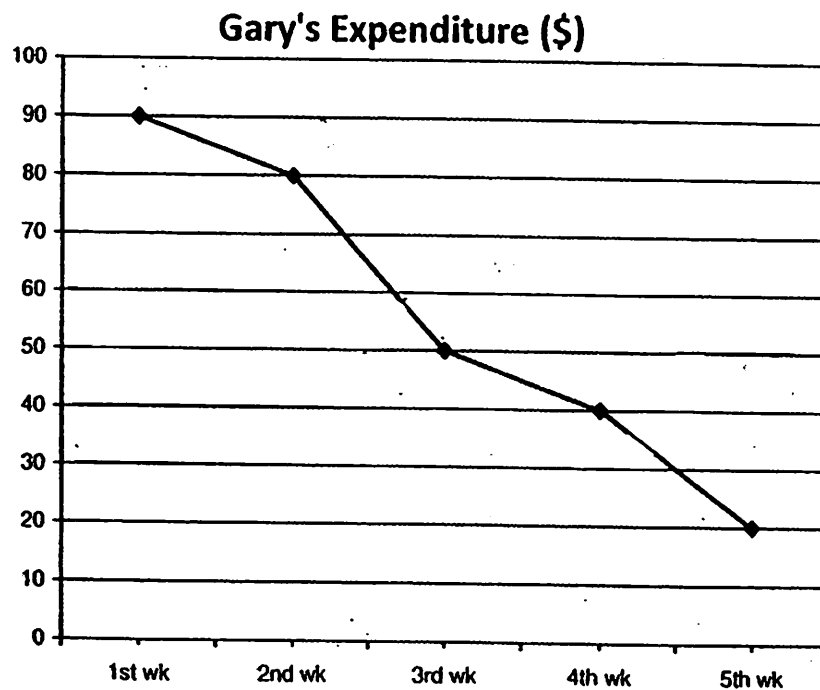

When was there a 20% decrease in Gary's expenditure?

- 1) from 1st week to 2nd week
- 2) from 2nd week to 3rd week
- 3) from 3rd week to 4th week
- 4) from 4th week to 5th week

10. The figure shows a cube with letter E and T on it.

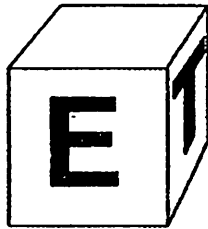

Which square will the letter T be in the net below?

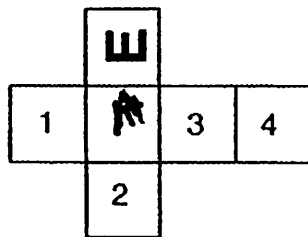

- 1) 1
 - 2) 2
 - 3) 3
 - 4) 4
11. Box A can hold either 18 big cubes or 72 small cubes. If there are already 4 big cubes and 10 small cubes in Box A, how many more small cubes can Box A hold?
- 1) 46
 - 2) 50
 - 3) 58
 - 4) 62

12. In the figure, $ABCE$ is a rectangle, ABD is an isosceles triangle. Find $\angle ABD$.

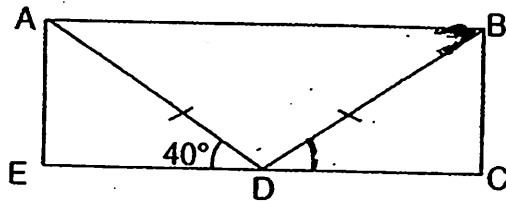

- 1) 20°
 - 2) 40°
 - 3) 45°
 - 4) 50°
13. Jensen uses a ruler to measure the length of a crayon.

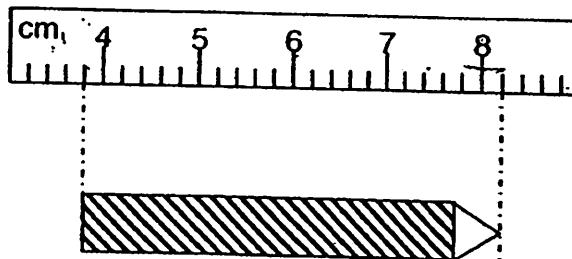

Which of the following is the closest to the length of the crayon shown above?

- 1) 4.2 cm
- 2) 4.4 cm
- 3) 8.1 cm
- 4) 8.2 cm

14. Tom, Mandy and Keith shared a sum of money. Keith received three times as much money as Mandy and \$6 less than Tom. If Keith received \$18, find the average amount of money each of them received.

- 1) \$ 14
- 2) \$ 16
- 3) \$ 42
- 4) \$ 44

15. Keegan and Joe saved some money. $\frac{2}{5}$ of Keegan's savings was equal to $\frac{1}{3}$ of Joe's savings. What was the ratio of Keegan's savings to their total savings?

- 1) 5 : 6
- 2) 6 : 5
- 3) 5 : 11
- 4) 11 : 5

--	--	--	--	--	--	--

Anglo-Chinese School (Junior)/
Anglo-Chinese School (Primary)



**COMBINED PRELIMINARY EXAMINATION (2011)
PRIMARY 6**

MATHEMATICS

**PAPER 1
Booklet B**

Wednesday

24 AUGUST 2011

50 min

INSTRUCTIONS TO PUPILS

1. Do not turn over this page until you are told to do so
2. Follow all instructions carefully.
3. Answer all questions.
4. Write your answers in this booklet.
5. You are not allowed to use a calculator.

Name : _____ ()

Class : 6.()

Parent's Signature: _____

Booklet	Possible Marks	Marks Obtained
A	20	
B	20	
TOTAL	40	

This question paper consists of 8 printed pages. (Inclusive of cover page)

Questions 16 to 25 carry 1 mark each. Write your answers in the spaces provided. Give your answers to the units stated and to its simplest form whenever necessary. (10 marks)

16. Express $2\frac{5}{8}$ as a decimal.

Answer: _____

17. In $37 \times 29 = \square \times 29 - 3 \times 29$, what is the missing number in the box?

Answer: _____

18. Eugene, Aaron and Marc shared \$49 among themselves. Aaron received twice as much money as Eugene. Marc received twice as much money as Aaron. How much money did Eugene receive?

Answer: \$ _____

19. Put a pair of brackets in the number statement to make it mathematically correct.

$$10 - 6 \div 3 + 3 - 4 = 1$$

Answer: _____

20. The clock shown below is 35 minutes slower. What is the actual time?

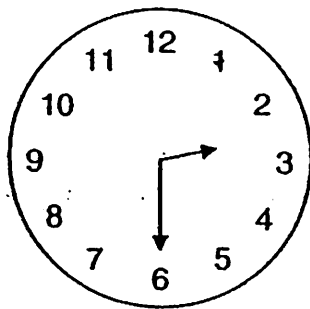

Answer: _____ p.m.

21. What is the area of the triangle shown below?

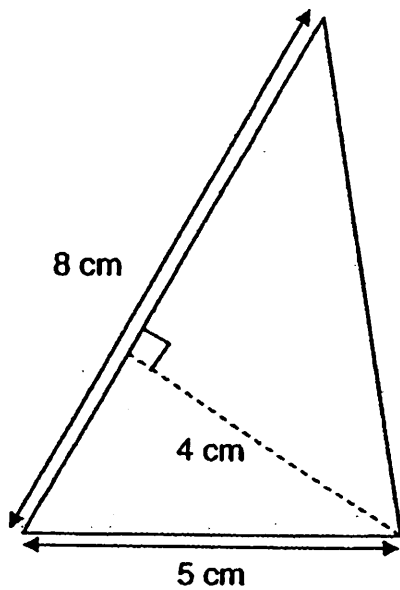

Answer: _____ cm²

22. Matthew is standing in the centre of 9 big tiles facing A. Which letter will he face when he turns 225° clockwise?

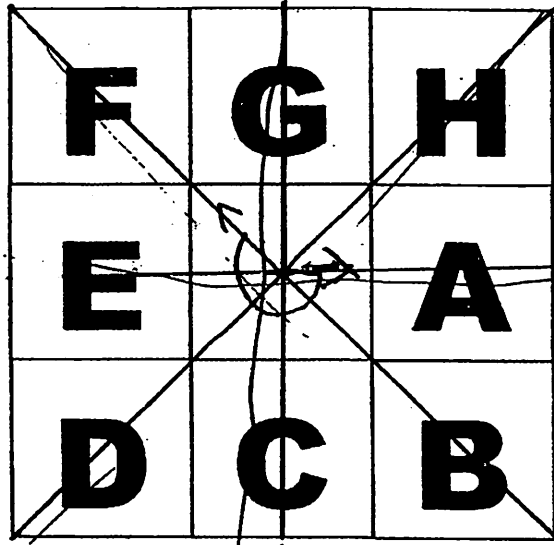

Answer: _____

23. There were r boys in a cooking class. There were three times as many girls as boys in the class. If the teacher baked 240 cookies to be shared equally among the children, how many cookies would each child get?

Answer: _____

24. The figure below is made up of similar squares. If the total area of the figure is 27 m^2 , what is the perimeter of the figure?

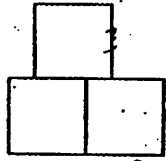

Answer: _____ m

25. Complete the figure below so that the dotted line AB is the line of symmetry.

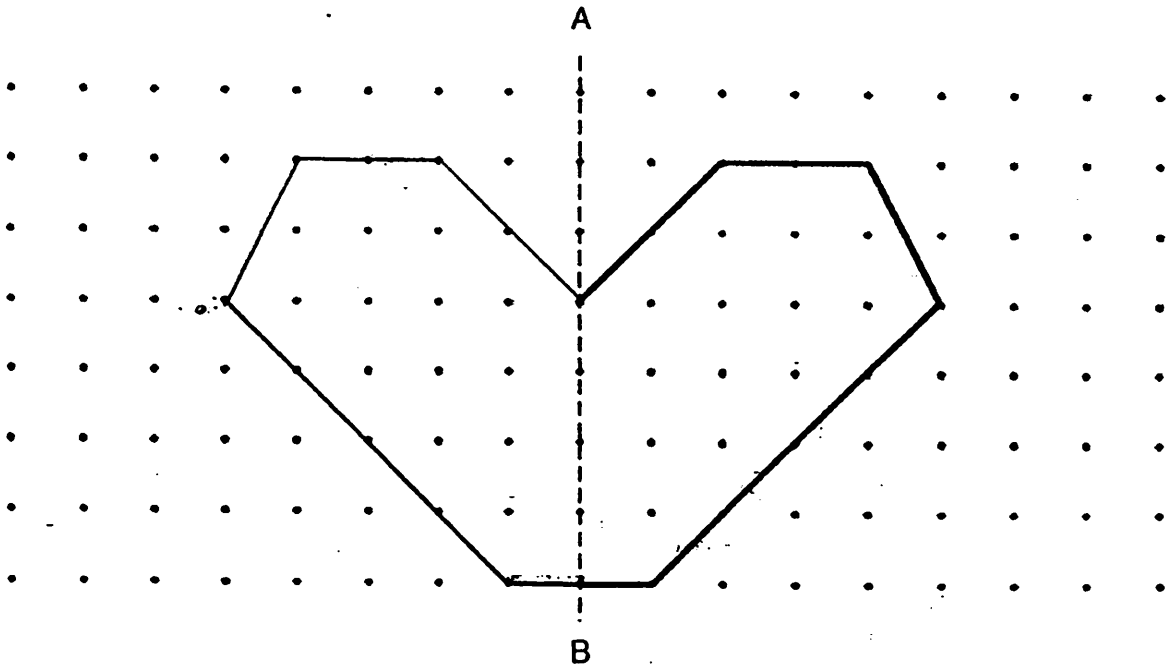

Questions 26 to 30 carry 2 marks each. Show all mathematical statements clearly in the space below each question and write your answers in the spaces provided. Give your answers to the units stated and to its simplest form whenever necessary. (10 marks)

26. At first Alvin had twice as many trading cards as Steven. After Alvin had given away 285 of his trading cards, Steven had twice as many trading cards as Alvin. How many trading cards did they have altogether at first?

Answer: _____

27. The figure consists of 2 squares and a circle. What fraction of the figure is shaded?

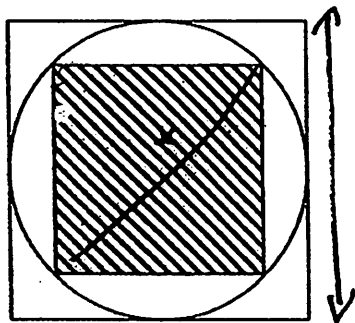

Answer: _____

28. $\frac{2}{3}$ of a number is smaller than two times of the same number by 20a.
What is the number?

Answer: _____

29. Marcus and Henry received their PSLE results. However, some digits from their aggregate scores were smeared with ink as shown below. The average of their 3-digit aggregate scores was 239. What was Henry's largest possible aggregate score?

Pupil	Aggregate Scores
Marcus	22*
Henry	*8

Answer : _____

30. Paula baked 18 more fruit cakes than chocolate cakes. After giving away 35 cakes of each type, the number of chocolate cakes became 75% of the number of fruit cakes. How many chocolate cakes had she left?

Answer: _____

--	--	--	--	--	--	--

Anglo-Chinese School (Junior)
Anglo-Chinese School (Primary)



COMBINED PRELIMINARY EXAMINATION (2011)
PRIMARY 6

MATHEMATICS

PAPER 2

Wednesday

24 AUGUST 2011

1hr 40 min

INSTRUCTIONS TO PUPILS

1. Do not turn over this page until you are told to do so
2. Follow all instructions carefully.
3. Answer all questions.
4. Show all your workings as marks are awarded for correct working.
5. Write your answers in this booklet.
6. You are allowed to use a calculator.

Name : _____ ()

Class : 6.()

Parent's Signature: _____

Paper	Possible Marks	Marks Obtained
1	40	
2	60	
TOTAL	100	

This question paper consists of 14 printed pages. (Inclusive of cover page)

Questions 1 to 5 carry 2 marks each. Show your mathematical statements clearly in the space provided for each question and write your answers in the spaces provided. Give your answers to the units stated and to its simplest form whenever necessary. (10 marks)

1. How many words can Perry type from 2.15 p.m. to 3.30 p.m. at a rate of 40 words per minute?

Answer: _____

2. The area of a rectangle is 162 m^2 . The breadth of the rectangle is more than 6 m. The length is twice of the breadth. Both the length and the breadth are whole numbers. What is the length of the rectangle?

Answer: _____ m

3. The figure shows a circle of radius 56 cm. Using the calculator value of π , find the perimeter of the shaded part of the figure? Give your answer correct to 1 decimal place.

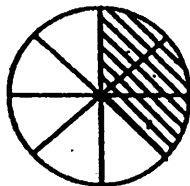

Answer: _____

4. Mr Han bought 34 belts. He sold half of them at \$23 each and the rest at \$21.50 each. What was the average price of the 34 belts?

Answer: _____

5. In the figure below, find $\angle x$.

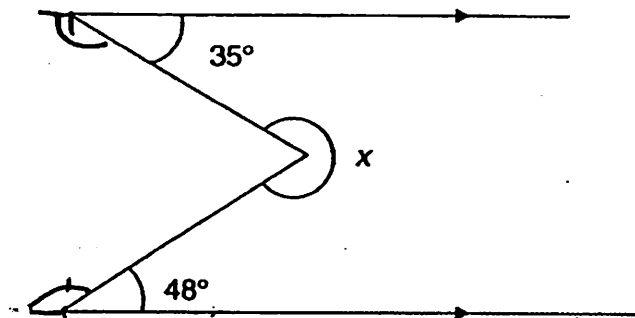

Answer: _____^o

For questions 6 to 18, show your steps clearly in the space provided for each question and write your answers in the spaces provided.
For questions which require units, give your answers in the units stated.
The number of marks available is shown in brackets [] at the end of each question or part-question. (50 marks)

6. Tim and Jonathan can paint a room in 2 h together. If Tim is painting the room alone, he can only complete the task in 6 h. How long will Jonathan take to paint a room all by himself?

Answer: _____ [3]

7. Lu Lu Garments imported T-shirts from overseas and sorted them into 3 different colours. $\frac{3}{7}$ of the T-shirts were red and $\frac{2}{5}$ of the T-shirts were green. The rest of the T-shirts were yellow. There were 912 more green T-shirts than yellow T-shirts. How many green T-shirts were imported?

Answer : _____ [3]

8. Some unit shapes in the tessellation below are incorrectly drawn.

(a) Identify two unit shapes which are incorrect and shade them. [1]

(b) Extend the tessellation by drawing two more unit shapes in the space provided within the box. [2]

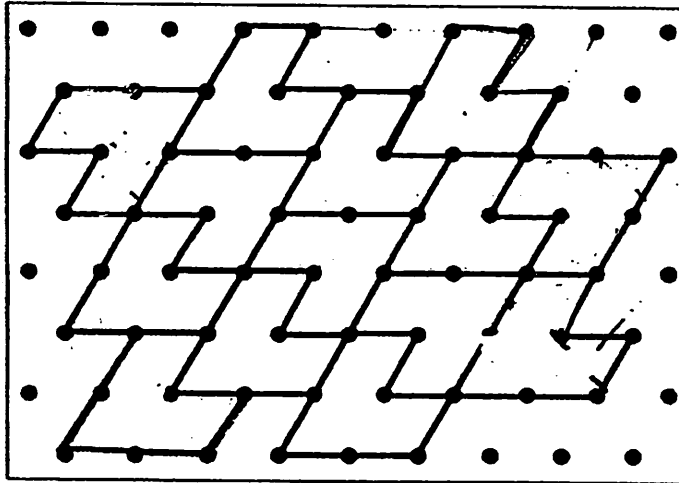

9. Mr Lee bought some T-shirts for \$425. If he was given a discount of 15%, he would be able to buy 5 more identical T-shirts for the same amount of money. What was the original price of each T-shirt?

Answer: _____ [3]

10. A survey on 720 pupils' preference for pets was conducted in a school and the findings are presented in the pie chart below.

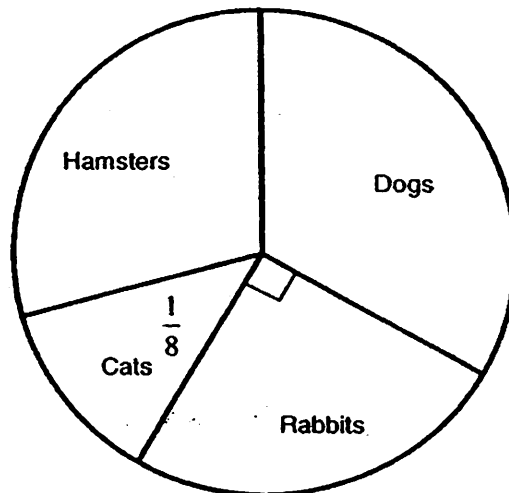

- (a) What fraction of the pupils like to keep hamsters as pets? (Give your answer in its simplest form)
- (b) How many more pupils like dogs than cats?

Answer: (a) _____ [1]

(b) _____ [2]

11. The price of one egg tart is \$0.90 from Delicious Bakery. For every 3 egg tarts a customer buys, he can buy the fourth one at half the price. What is the greatest number of egg tarts that a customer can buy with \$72?

Answer: _____ [4]

12. The figure shows a quadrant.
 Find
 (a) $\angle x$.
 (b) $\angle y$.

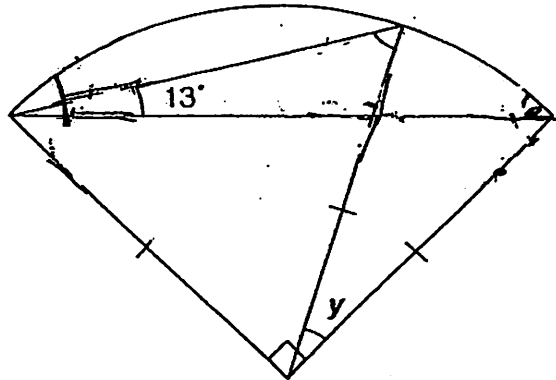

Answer : a) _____ [2]

b) _____ [2]

13. In a hall, there are 16 rows of 19 chairs each. Mr Wong wishes to rearrange these chairs into a square with the same number of chairs on each side. There are no chairs inside the square. How many chairs will there be on each side of the square?

Answer : _____ [4]

14. Two wheels shown below with centres X and Y are 115 cm apart. The diameter of the big wheel is 70 cm. The ratio of the radius of the small wheel to the radius of the big wheel is 2 : 5. Both wheels are rolled out in opposite direction shown until they are 1347 cm apart. The two wheels need to make the same number of revolutions. How many revolutions does each wheel make assuming that each wheel must make a complete revolution? (Take $\pi = \frac{22}{7}$).

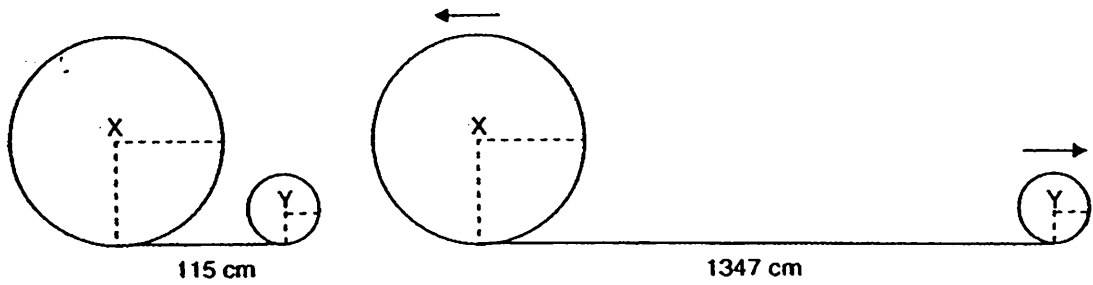

15. The distance between Town A and Town B was 520 km. At 8.30 a.m., a van left Town A for Town B travelling at a constant speed. At the same time, a car travelling at a constant speed set off from Town B towards Town A. The two vehicles met each other at 12.30 p.m. The car was travelling at 20 km/h faster than the van. What was the speed of the car?

16. Lawrence had some money. He spent $\frac{3}{5}$ of it on 4 similar highlighters. With the rest of his money, he bought another 2 such highlighters and 10 rulers.
- (a) What fraction of his money was spent on buying 10 rulers?
Give your answer in its simplest form.
- (b) In a sale, Lawrence would be given 1 free ruler for every 12 rulers bought. How many rulers would he get altogether if he had spent all his money at first on rulers?

Answer : a) _____ [2]

b) _____ [3]

17. A rectangular tank with a base area of 500 cm^2 and a height of 12 cm contains some water. When some identical cubes are put into it, it becomes $\frac{5}{6}$ filled. Each identical cube has sides of 5 cm . He then removes all the cubes and the tank is $\frac{2}{3}$ filled with water only.

- (a) What is the volume of water in the tank?
- (b) How many cubes has he put into the tank at first?

Answer: (a) _____ [1]

(b) _____ [4]

18. Jason, Edward and Sam had a total of \$837. Jason had the least amount of money. The ratio of Edward's money to Sam's money was 4 : 3 at first. Jason and Edward each spent $\frac{1}{3}$ of their money. Given that the three boys had \$648 left, how much did Jason have at first?

Answer: _____ [5]

End of Paper 2

Anglo-Chinese School
Combined Preliminary Examination (2011)
Mathematics, Primary 6
Paper 1 (Booklet A)

Q1	Q2	Q3	Q4	Q5	Q6	Q7	Q8	Q9	Q10
3	3	3	3	4	3	2	2	3	4
Q11	Q12	Q13	Q14	Q15					
1	2	2	2	3					

Booklet B

Q16) $0.125 \times 6 = 0.625$ | $2 + 0.625 = \underline{2.625}$

Q17) 40 | Q18) $49 / 7 = \underline{\$7}$ | Q19) $10 - (6 / 3 + 3) - 4 = 1$

Q20) 3.05pm | Q21) 16 | Q22) F | Q23) $\frac{60}{R}$ | Q24) 24

Q26) $2(2u - 285) = 1u$ | $4u - 285 = 1u$ | $3u = 285$
 Cards at first = $285 \times 3 = \underline{845}$

Q27) $\frac{x}{2} \times \frac{x}{2} = \frac{x^2}{4}$ | $\frac{x^2}{4} \times 2 = \frac{x^2}{2}$ |

$\frac{x^2}{2} : x^2$ | $\frac{x}{2} : X$ | $x : 2x$ | $1 : 2 = \frac{1}{2}$

Q28) $\frac{2}{3}n + 20a = 2nn$ | $20a = 1\frac{1}{3}m$ | $20a = \frac{4}{3}m$
 $60a = 4m$ | $m = \underline{15a}$

Q29) $239 \times 2 = 478$ | $478 - 8 = 470$ | $470 - 220 = 250$ |
 $250 + 8 = \underline{258}$

Q30) $F = c + 18$ | $c - 35 = \frac{3}{4}(f - 35)$ | $c - 35 = \frac{3}{4}(c + 18 - 35)$

$c - 35 = \frac{3}{4}(c - 17)$ | $4c - 140 = 3(c - 17)$ | $4c - 140 = 3c - 51$

$c = 140 - 51 = 89$ | $89 - 35 = \underline{54}$

Anglo-Chinese School
Combined Preliminary Examination (2011)
Mathematics, Primary 6
Paper 2

Q1) $1\text{hr}15\text{mins} = 75\text{mins}$ | $75 \times 40 = \underline{3000}$

Q2)

Breadth	Length	Area	✓ / ×
7	14	98	×
8	16	128	×
9	<u>18</u>	162	✓

The length is 18m.

Q3) $\pi \times 112 = 351.86\text{cm}$ | $351.86 / 8 = 43.9825 = 43.98$
 $43.98 \times 3 = 131.94$ | $131.94 + 56 + 56 = 243.94 = \underline{243.9}$

Q4) $34 / 2 = 17$ | $17 \times 23 = 391$ | $17 \times 21.5 = 365.5$
 $365.5 + 391 = 756.5$ | $756.5 / 34 = \underline{\$22.25}$

Q5) $90^\circ - 48^\circ = 42^\circ$ | $90^\circ - 35^\circ = 55^\circ$ | $180^\circ - 55^\circ - 42^\circ = 83^\circ$
 $360^\circ - 83^\circ = \underline{277^\circ}$

Q6) $T(2\text{hrs}) + J(2\text{hrs}) = 1\text{room}$ | $T(6\text{hrs}) = 1\text{ room}$
 $T(6\text{hrs}) + J(6\text{hrs}) = 3\text{rooms}$ | $J(6\text{hrs}) = 3 - 1\text{ room} = 2\text{rooms}$
 Time taken by Jonathan to paint a room alone = $6\text{hrs} / 2 = \underline{3\text{hours}}$

Q7) $\frac{15}{35}$ red | $\frac{14}{35}$ green | $1 - \frac{15}{35} - \frac{14}{35} = \frac{6}{35}$
 $14 - 6 = 8$ | $8u = 912$ | $1u = 912 / 8 = 114$ |
 Green T-shirts = $114 \times 14 = \underline{1596}$

Q9) $15\% \rightarrow 5$ more T-shirts | $100\% = \$425$ | $1\% = 425 / 100 = 4.25$
 $15\% = 4.25 \times 15 = 63.75$ | $5u = 63.75$ | $1u = 63.75 / 5 = 12.75$
 Original price = $12.75 / 85 \times 100 = \underline{\$15}$

Q10) a) $1 - \frac{1}{4} - \frac{1}{8} - \frac{1}{3} = \frac{7}{24}$ | b) $\frac{1}{3} - \frac{1}{8} = \frac{5}{24}$ | $\frac{5}{24} \times 720 = \underline{150 \text{ more}}$
pupils

Q11) 1 egg tart = 0.9 | 4 egg tart = $(0.9 \times 3) + 0.45 = 3.15$
 $72 / 3.15 = 22.85 = 22$ | $22 \times 4 = 88$ | $22 \times 3.15 = \$69.3$

$$\begin{aligned} \$ \text{ left over} &= \$72 - \$69.3 = \$2.70 & | & \quad \text{No. of extra egg tarts} = 2.7 / 0.9 = 3 \\ \text{Total no. of egg tarts} &= 88 + 3 = \underline{\underline{91 \text{ egg tarts}}} \end{aligned}$$

$$\begin{aligned} \text{Q12a) } 90 - 26 &= 64 & | & \quad X = (180 - 64) / 2 = \underline{\underline{58^\circ}} \\ \text{b) } 180 - 45 - 13 &= 122 & | & \quad 180 - 122 = 58 & | & \quad 180 - 122 - 32 = \underline{\underline{26^\circ}} \end{aligned}$$

$$\text{Q13) } 16 \times 19 = 304 \quad | \quad 304 + 4 = 308 \quad | \quad 308 / 4 = \underline{\underline{77 \text{ chairs}}}$$

$$\begin{aligned} \text{Q14) Big Wheel} &= \frac{22}{7} \times 70 = 220\text{cm} & | & \quad \text{Small Wheel} = x \times 28 = 88\text{cm} \\ \text{Total revolutions} &= 1232 / (220+88) = \underline{\underline{4 \text{ revolutions.}}} \end{aligned}$$

$$\begin{aligned} \text{Q15) } 20 \times 4 &= 80 & | & \quad (620 - 80) / 2 = 220 & | & \quad 220 + 80 = 300 \\ 300 / 4 &= \underline{\underline{75\text{km/h}}} \end{aligned}$$

$$\begin{aligned} \text{Q16a) } 4 \text{ highlighters} &= \frac{3}{5} & | & \quad 1 \text{ highlighter} = \frac{3}{5} / 4 = & | & \quad \frac{3}{20} \times 2 = \frac{6}{20} \\ \frac{2}{5} - \frac{6}{20} &= \frac{1}{10} & \text{ of his money was spent on 10 ruler.} \\ \text{b) } 100 / 12 &= 8 \text{ r } 4 & | & \quad 8 \times 12 = 96 & | & \quad 96 + 8 = 104 & | \\ 104 + 4 &= \underline{\underline{108 \text{ rulers}}} \end{aligned}$$

$$\text{Q17a) } \frac{2}{3} \times 12 \times 500 = \underline{\underline{4200 \text{ cm}^3}}$$

$$\begin{aligned} \text{b) } 5 \times 5 \times 5 &= 125 & | & \quad 500 \times 12 \times \frac{2}{3} = 4000 & | & \quad 5000 - 4000 = 1000 \\ 1000 / 125 &= \underline{\underline{8 \text{ cubes}}} \end{aligned}$$

$$\begin{aligned} \text{Q18) Spent} &= 837 - 648 = 189 & | & \quad 837 - 567 = 270 & | & \quad 270 / 9 = 3 \\ 30 \times 12 &= 360 & | & \quad \text{Amount Jason had at first} = 837 - 270 - 360 = \underline{\underline{\$207}} \end{aligned}$$