



HENRY PARK PRIMARY SCHOOL  
2011 PRELIMINARY EXAMINATION  
MATHEMATICS  
PRIMARY 6

PAPER 1  
(BOOKLET A)

Name: \_\_\_\_\_ (    )

Class: Primary 6 \_ \_\_\_\_\_

Marks:

Paper 1	Booklet A	/20
	Booklet B	/20
Paper 2		/60
Total		/100

Total Time for Booklets A and B: 50 min

Do not turn over this page until you are told to do so.

Follow all instructions carefully.

Answer all questions.

Shade your answers in the Optical Answer Sheet (OAS) provided.

The use of calculators is **NOT** allowed.

Questions 1 to 10 carry 1 mark each. Questions 11 to 15 carry 2 marks each. For each question, four options are given. One of them is the correct answer. Make your choice (1, 2, 3, 4). Shade the oval (1, 2, 3, 4) on the Optical Answer Sheet.

1. Mr Lim bought a car for about \$119 000 when rounded off to the nearest thousand. Which of the following could be the actual cost of the car?

(1) \$118 095

(2) \$118 495

(3) \$119 259

(4) \$119 625

2. Which of the following is equal to  $5\frac{1}{3}$ ?

(1)  $5 \div \frac{1}{3}$

(2)  $5 \times \frac{1}{3}$

(3)  $16 \times \frac{1}{3}$

(4)  $16 \div \frac{1}{3}$

3. Jean left for her school when her watch showed 7.45 a.m. Her watch was 10 minutes slow. She took 55 minutes to travel to her school for extra lessons. When she arrived, she found that she was 10 minutes early for her class. What time was her class supposed to start?

(1) 8.20 a.m.

(2) 8.40 a.m.

(3) 8.50 a.m.

(4) 9.00 a.m.

4. The figure below shows part of a ruler. What is the best estimate of the reading indicated by the arrow?

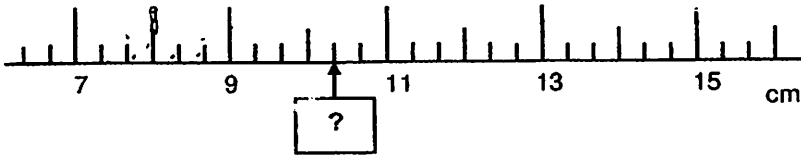

- (1) 10.3 cm
- (2) 10.1 cm
- (3) 9.6 cm
- (4) 9.4 cm

5. Sally represented the amount of money she spent on groceries, food and clothes using a pie chart. She spent  $\frac{5}{8}$  of her money on groceries,  $\frac{1}{4}$  of her ~~money on food and the remaining amount on clothes.~~ Which of the following pie charts can be best used to represent the information given above?

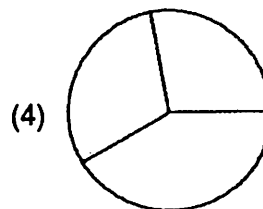
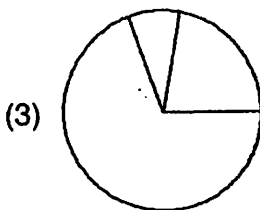
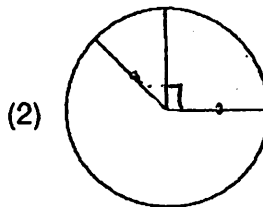
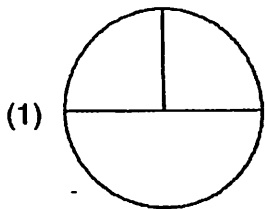

6. David's average score for 2 tests was 70. David obtained an average score of 74 after the third test. What was the score of his third test?

- (1) 48
- (2) 72
- (3) 78
- (4) 82

7. Each figure below is made of 16 squares. Four squares in each figure are shaded. Which of the following figures will have a line of symmetry when 1 more square is shaded?

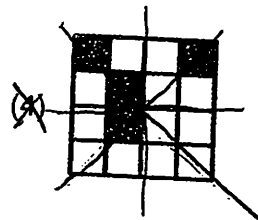
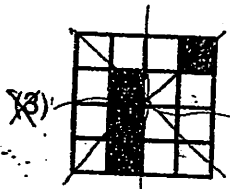
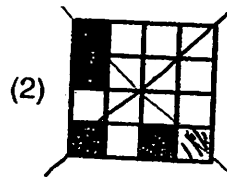
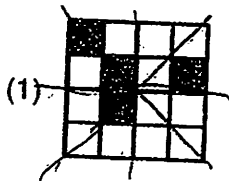

8. What is the sum of 8 tenths and 12 thousandths?

- (1) -0.092
- (2) 0.200
- (3) 0.812
- (4) 0.902

9. The figure below shows a cube.

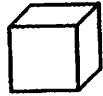

Which one of the following is not a net of the cube?

(1)

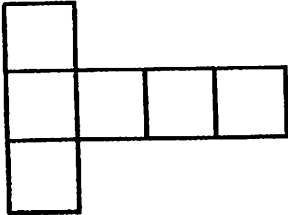

(2)

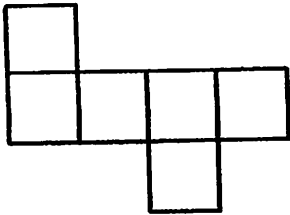

(3)

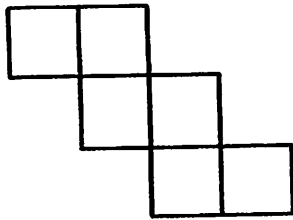

(4)

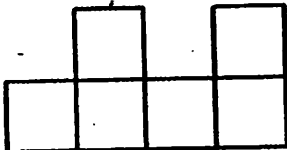

10. Mandy is 168 cm tall. She is  $y$  cm shorter than her sister. What is their total height?

(1)  $(168 + y)$  cm

(2)  $(168 - y)$  cm

(3)  $(336 + y)$  cm

(4)  $(336 - y)$  cm

11. Mr Lim had some red and green beads. 60% of his beads were red and the rest were green. He lost some of his red beads and the percentage of the beads which were red decreased by 40%. He then had 760 red and green beads left. How many red beads did he lose?

(1) 190

(2) 240

(3) 285

(4) 360

12. The table below shows the number of hours spent on computer games per week by each pupil from a class.

Number of hours spent by each pupil on computer games	1	3	?
Number of pupils	6	8	10

There are 24 pupils in the class. The average number of hours the pupils spent on computer games was 5 hours. What is the missing number in the table?

(1) 15

(2) 12

(3) 9

(4) 4

13. In the figure, WXYZ is a square and UVZ is an isosceles triangle.  $\angle WUZ = 75^\circ$  and  $\angle UVX = 51^\circ$ . Find  $\angle UZV$ .

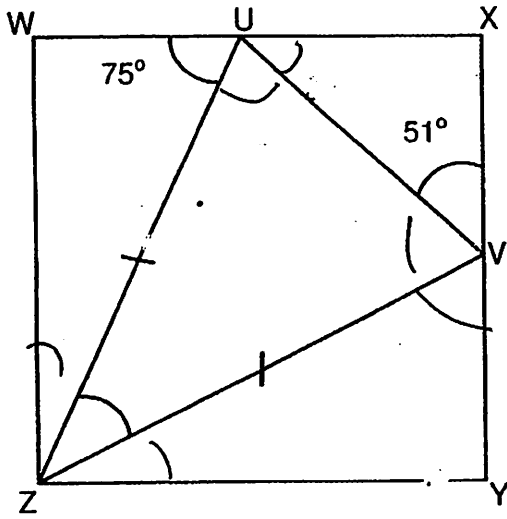

- (1)  $36^\circ$   
 (2)  $48^\circ$   
 (3)  $66^\circ$   
 (4)  $68^\circ$
14. George and Henry had \$1080 altogether. When Henry gave  $\frac{1}{6}$  of his money to George, they had the same amount of money. How much money did George have at first?
- (1) \$108  
 (2) \$432  
 (3) \$648  
 (4) \$720

15. The figure below shows the net of a cuboid with a square base. What is the maximum number of 3-cm cubes that can be packed into the cuboid?

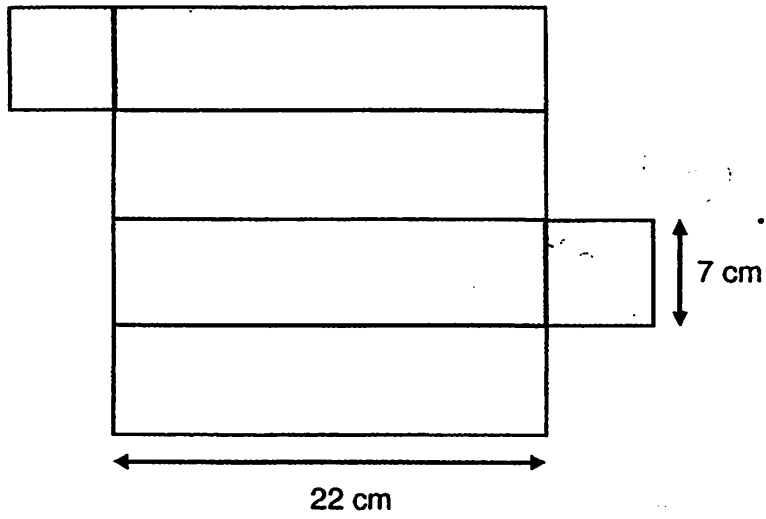

- (1) 28
- (2) 32
- (3) 40
- (4) 120



HENRY-PARK PRIMARY SCHOOL  
2011 PRELIMINARY EXAMINATION  
MATHEMATICS  
PRIMARY 6

PAPER 1  
(BOOKLET B)

Name: \_\_\_\_\_ ( )

Class: Primary 6 \_\_\_\_\_

Total Time for Booklets A and B: 50 min

Do not turn over this page until you are told to do so.

Follow all instructions carefully.

Answer all questions.

Write your answers in this booklet.

The use of calculators is **NOT** allowed.

Questions 16 to 25 carry 1 mark each. Write your answers in the spaces provided. For questions which require units, give your answers in the units stated. (10 marks)

Do not write in this space

16. Find the value of  $38.4 \div 8$ .

Ans: \_\_\_\_\_

17. What is the value of  $24 - 18 \div 3 \times 4 \div 12$ ?

Ans: \_\_\_\_\_

18. The figure below shows two semicircles. X is the centre of the bigger semicircle of radius 8 cm. Find the perimeter of the shaded portion. Leave your answer in terms of  $\pi$ .

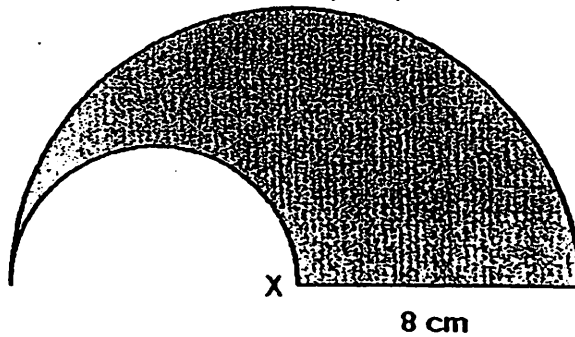

Ans: \_\_\_\_\_ cm

Score

19. A piece of string of length 110 cm were cut into identical pieces. 10 cuts were made on the string to obtain the identical pieces. What is the length of 1 piece of string?

Do not write in this space

Ans: \_\_\_\_\_ cm

20. The shaded figure below is formed with 3 big and 3 small equilateral triangles. The length of the straight line AB is 63 cm. What is the perimeter of the shaded figure?

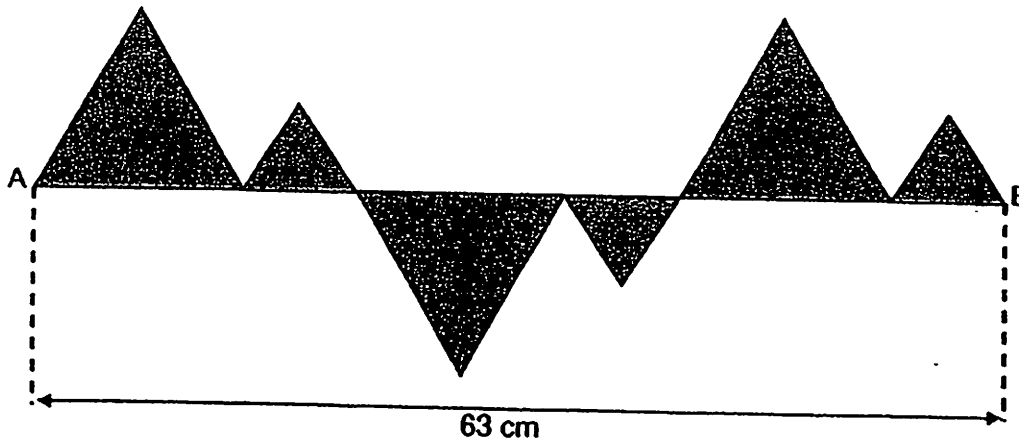

Ans: \_\_\_\_\_ cm

Score

--

Use the information below to answer questions 21 and 22.

Do not write  
in this space

The pie chart below shows the enrolment of different types of CCA in a school. The enrolment of the Badminton CCA is twice the enrolment of the Table Tennis CCA.

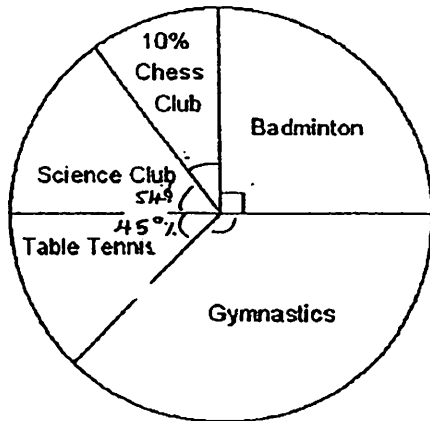

21. What is the ratio of the enrolment of the Gymnastics CCA to the Science Club CCA?

Ans: \_\_\_\_\_

22. The enrolment of the Science Club CCA was 8 more than the Table Tennis CCA. What was the enrolment of the Badminton CCA?

Ans: \_\_\_\_\_

Score

--

Do not write  
in this space

23. The pattern in the box shows part of a tessellation. Extend the tessellation by drawing two more unit shapes in the space provided within the box.

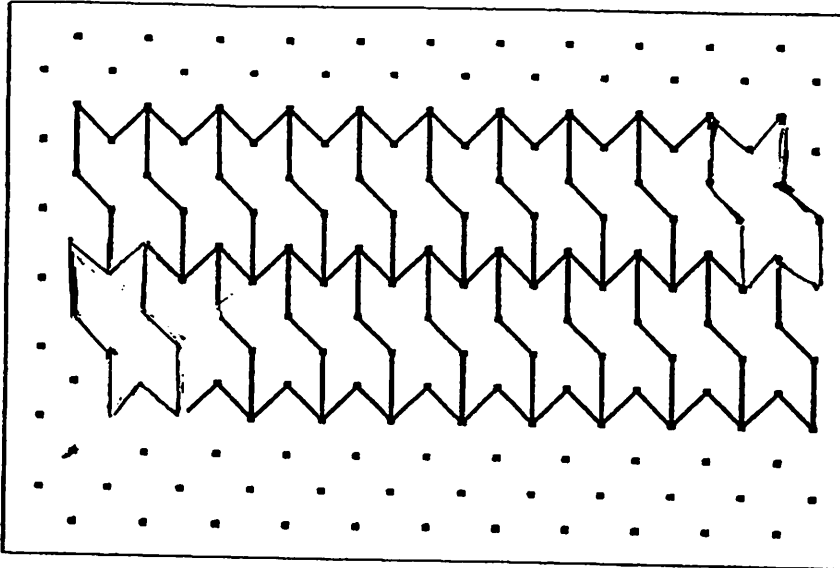

24. In the figure below,  $\triangle XYZ$  is an equilateral triangle and  $\triangle XWZ$  is a right-angled isosceles triangle. Find  $\angle WXY$ .

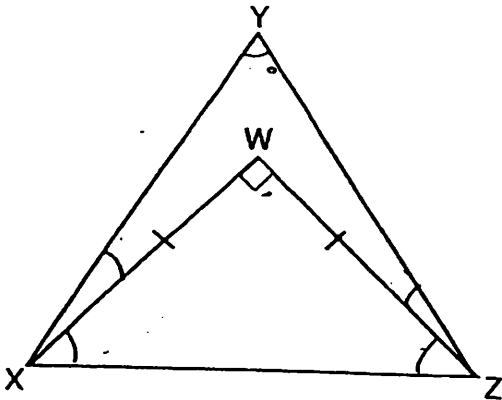

Ans: \_\_\_\_\_ °

Score

Do not write  
in this space

25. John donated  $\frac{1}{4}$  of his cards and Joseph donated  $\frac{2}{3}$  of his cards. They have the same number of cards left. What is the ratio of the number of cards John has to the number of cards Joseph has at first?

Ans: \_\_\_\_\_

---

Score

Questions 26 to 30 carry 2 marks each. Show your working clearly and write your answers in the spaces provided. For questions which require units, give your answers in the units stated. ( 10 marks )

Do not write in this space

26. One apple cost \$0.65 and one pear cost \$0.75. Mrs Lee paid \$28 for an equal number of apples and pears. How many fruits did she buy altogether?

Ans: \_\_\_\_\_

27. The figure below shows two identical isosceles triangles. Find  $\angle a$ .

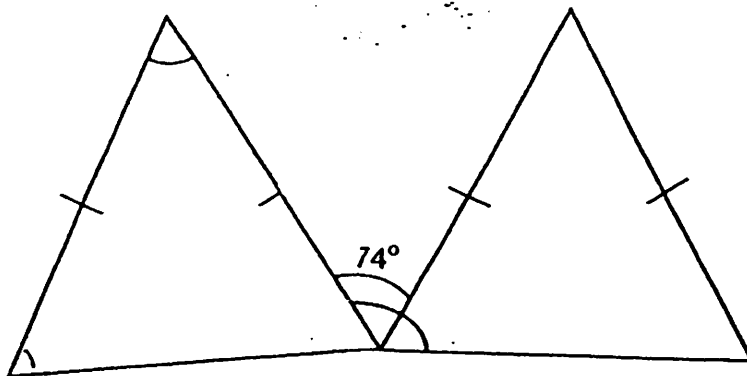

Ans: \_\_\_\_\_ °

Score

--

Do not write  
in this space

28. James had half the number of stickers Ali had. After Ali gave away  $\frac{1}{3}$  of his stickers and James gave away  $\frac{1}{4}$  of his stickers, James had 27 stickers left. How many stickers did both of them have altogether at first?

Ans: \_\_\_\_\_

29. A glass bottle filled with 6 identical ball-bearings weighs 1.05 kg. The same bottle when filled with 8 marbles weighs 830 g. The mass of each ball-bearing is five times the mass of each marble. What is the mass of the empty glass

Ans: \_\_\_\_\_ g

30. Mrs Tan took the same number of vitamin pills each day. After 2 days, she had  $\frac{4}{5}$  of the pills left. After another 5 days, she had 24 pills left. How many pills had she at first?

Ans: \_\_\_\_\_

Score

--



HENRY PARK PRIMARY SCHOOL  
2011 PRELIMINARY EXAMINATION  
MATHEMATICS  
PRIMARY 6

PAPER 2

Name: \_\_\_\_\_ (    )

Class: Primary 6 \_\_\_\_\_

Time for Paper 2: 1 h 40 min

Do not turn over this page until you are told to do so.

Follow all instructions carefully.

Answer all questions.

Write your answers in this booklet.

The use of an approved calculator is expected, where appropriate.

Questions 1 to 5 carry 2 marks each. Show your working clearly and write your answers in the spaces provided. For questions which require units, give your answers in the units stated.

Do not write  
in this space

1. In the figure below, the length of the rectangle is twice that of its breadth. The perimeter of the rectangle is 96 cm. What is the area of the shaded triangle?

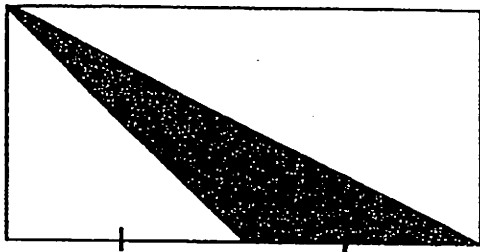

Ans: \_\_\_\_\_ cm<sup>2</sup>

2. A boat can take either 6 adults or 9 children. Given that there are 8 boats with 4 adults in each boat, what is the maximum number of children the boats can still take?

Ans: \_\_\_\_\_

Score

3.

BICYCLES FOR HIRE	
Charges per hour for bicycles	
Small bicycles	\$4
Medium bicycles	\$6
Big bicycles	\$8
Get an additional half an hour free for every 1 hour of rental	

Do not write  
in this space

Terrence hired a small, a medium and a big bicycle from 9 a.m. to 1 p.m.  
How much did he pay for hiring the bicycles?

Ans: \$ \_\_\_\_\_

4. Andre, Benny, Chris share a total of \$1144. Andre and Benny have \$778 and Benny and Chris have \$649. How much money does Benny have?

Ans: \$ \_\_\_\_\_

5. Mrs Tan recorded the test scores of her class of 30 pupils and calculated the average to be 81. One of her pupils' score of 81 was incorrectly recorded as 51. What was the correct average score of the test?

Ans: \_\_\_\_\_

Score

Do not write  
in this space

For questions 6 to 18, show your working clearly and write your answers in the spaces provided. The number of marks available is shown in brackets [ ] at the end of each question or part-question.

6. There were 76 more apples than oranges in a fruit stall. After 68 apples and 227 oranges were sold, the number of apples left was 6 times that of the number of oranges left. What was the total number of apples and oranges at the fruit stall at the start?

Ans: \_\_\_\_\_ [ 3 ]

7. The average age of 3 girls is  $x$  years. The oldest girl is 16 years old and the youngest girl is half as old as the oldest girl.

- (a) What is the age of the third girl?  
(b) If  $x = 13$ , what is the age of the third girl?

Ans: (a) \_\_\_\_\_ [ 2 ]

(b) \_\_\_\_\_ [ 1 ]

Score

--

8. Each of the figures below is made up of 1-cm sticks.

Do not write  
in this space

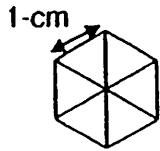

Figure 1

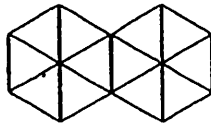

Figure 2

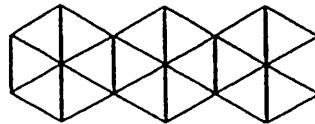

Figure 3

...

The table below shows the number of sticks used for each figure and the perimeter of each figure.

Figure Number	Number of 1-cm sticks	Perimeter (cm)
1	12	6
2	23	10
3	34	14
4	45	18

(a) Complete the table for Figure 4.

[ 1 ]

(b) Which Figure Number will have a perimeter of 1298 cm?

Ans: (b) \_\_\_\_\_ [ 2 ]

Score

8. Water was drained from a tank from 2 taps, Tap A and Tap B attached to it. Water was first drained from Tap A and after 6 minutes, water was also drained from Tap B. Both taps were then turned off at the same time after a period of time.

Do not write  
in this space

The graph below shows the amount of water in the tank over 12 minutes.

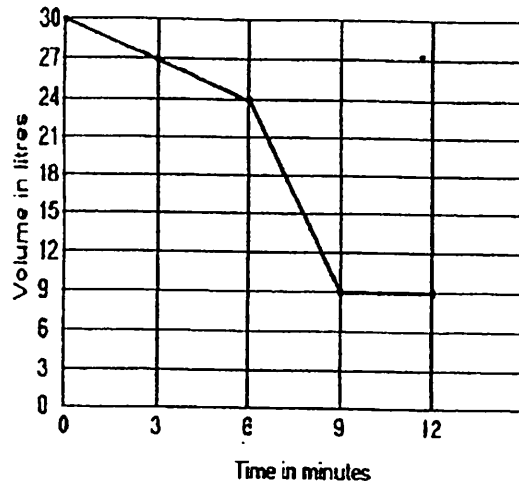

In one minute, how many litres of water were drained out from Tap B?

Ans: \_\_\_\_\_ [ 3 ]

Score

10. The figure is made up of a circle, identical semicircles and a square of side 12 cm. P is the centre of the circle.

Do not write in this space

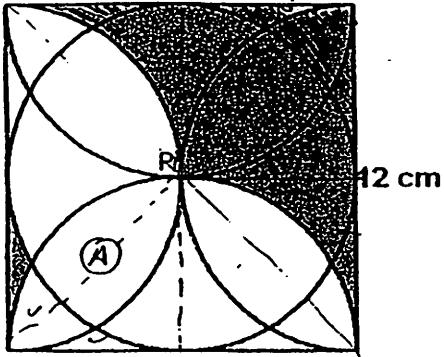

What is the area of the shaded figure? Leave your answer correct to two decimal places.

Ans: \_\_\_\_\_ [3]

Score

11. One side of a garden was double-fenced. The outer fencing had 3 wooden spokes along a length of 0.4 m and the inner fencing had 9 metal spokes along a length of 180 cm as shown in the diagram below.

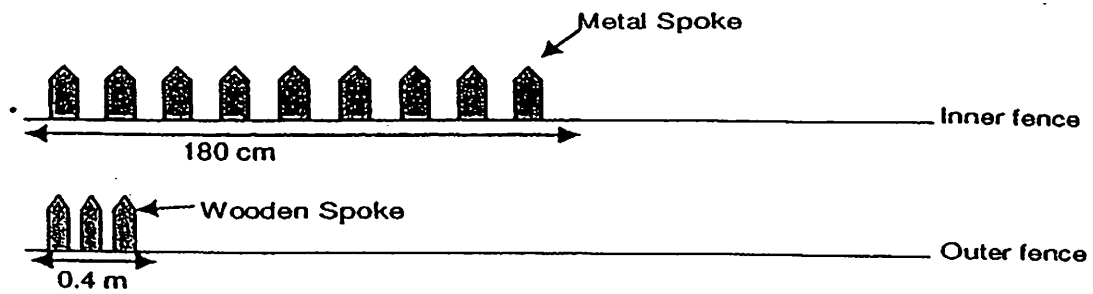

There were 198 more wooden than metal spokes . How many wooden and metal spokes were there altogether?

Do not write  
in this space

Ans: \_\_\_\_\_ [ 4 ]

Score

12. ABCD is a square and CDE is an equilateral triangle. AC and DF are straight lines.

Do not write in this space

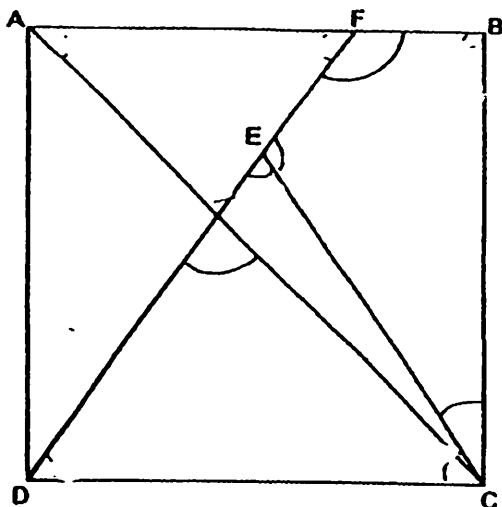

(a) Find the value of  $\angle x$ .

(b) Find the value of  $\angle y$ .

Ans: (a) \_\_\_\_\_ [ 2 ]

(b) \_\_\_\_\_ [ 2 ]

Score

--

13. Three boxes, A, B and C contained a certain number of counters. Box C contained  $\frac{1}{4}$  as many counters as A and B. There were 98 more counters in Box A than in Box C. Box B contained 174 more counters than Box C.

(a) How many counters did the three boxes contain altogether ?

(b) How many counters were in Box B?

Do not write  
in this space

Ans: (a) \_\_\_\_\_ [ 3 ]

(b) \_\_\_\_\_ [ 2 ]

Score

14. The figure shows an empty container made up of three cuboids. 28.9 litres of water is poured into one of the top cuboids into the cuboid below.

Do not write in this space

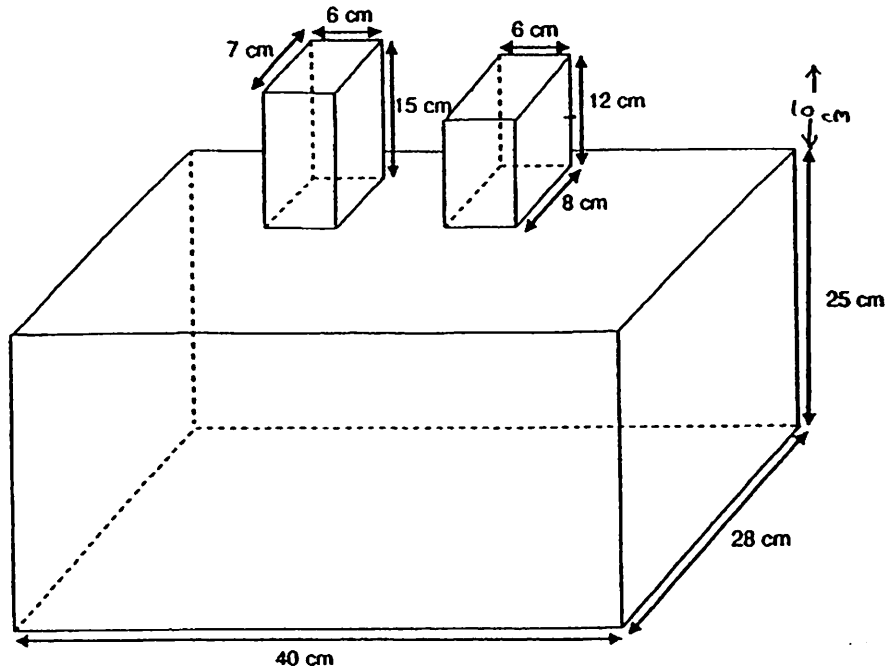

What is the height of the water level from the base of the container ?

Ans: \_\_\_\_\_ [ 5 ]

Score

15. Mr Lee packed some oranges into big boxes and apples into small boxes. Each big box contained 50 oranges and each small box contained 30 apples. After packing, there were 12 more big boxes than small boxes. Given that there were 1240 fewer apples than oranges, how many oranges were there?

Do not write  
in this space

Ans: \_\_\_\_\_ [5]

Score

16. Mr Lee took 7 hours to travel from Town A to Town B while Mr Wong took 8 hours to travel from Town B to Town A. Both of them did not change their speed throughout the journey. Both of them started off at the same time and moved towards each other. 3 hours later, they were 110 km apart. What was the speed Mr Lee was driving?

Do not write  
in this space

Ans:

---

[ 4 ]

---

Score

--

17. There were 1000 students at the parade ground and indoor sports hall. 40% of the 600 students at the parade ground were girls. 60% of the students at the indoor sports hall were girls. After some students in both venues moved from one venue to the other, 30% of the students in the parade ground and 70% of the students at the indoor sports hall were girls. How many students were there in the indoor sports hall after the movement had taken place?

Do not write  
in this space

Ans: \_\_\_\_\_ [ 4 ]

Score

18. A large warehouse had a total of 2180 black, red and white T-shirts for sale. The ratio of the number of black T-shirts to the number of red T-shirts was 3 : 1. After  $\frac{2}{5}$  of the black T-shirts,  $\frac{1}{3}$  of the white T-shirts and none of the red T-shirts were sold on the first day, there were 1504 T-shirts left. How many red T-shirts did the warehouse have at first?

Do not write  
in this space

Ans: \_\_\_\_\_ [ 4 ]

Score

# ANSWER SHEET

**EXAM PAPER 2011**

**SCHOOL : HENRY PARK  
SUBJECT : PRIMARY 6 MATHEMATICS**

**TERM : PRELIMINARY**

Q1	Q2	Q3	Q4	Q5	Q6	Q7	Q8	Q9	Q10	Q11	Q12	Q13	Q14	Q15
3	3	4	1	2	4	2	3	4	3	2	3	2	2	1

16)4.8                      17)22                      18) $(12\pi+8)$                       19)10cm                      20)189cm

21)5:2                      22)80

24)15°                      25)4:9

26)40                      27)38°

28)108                      29)750g

30)80

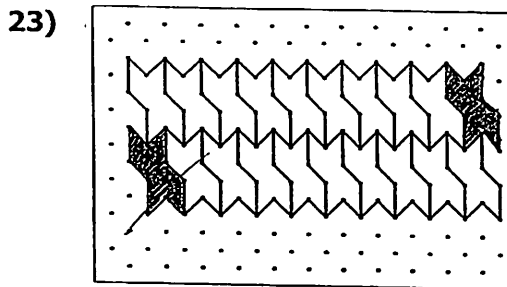

**Paper 2**

1)128cm<sup>2</sup>

9)4L/min

2)24

10)43.73cm<sup>2</sup>

3)\$54

11)0.4m = 40cm

4)\$778 + \$649 = \$1427  
\$1427 - \$1144 = \$283

$\left. \begin{array}{l} 3ws \rightarrow 40cm \\ 13.5ws \rightarrow 180cm \end{array} \right\} \times 4.5$   
 $13.5 - 9 = 4.5$   
 $198 \div 4.5 = 44$   
 $44 \times 9 = 396$   
 $44 \times 9 + 198 = 594$   
 $594 + 396 = 990 \text{ spokes}$

5)30 x 81 = 2430  
81 - 51 = 30  
2430 + 30 = 2460  
2460 ÷ 30 = 82

12)90° - 60° = 30°  
180° - 60° = 120°  
 $\angle y \rightarrow 360^\circ - 90^\circ - 30^\circ - 120^\circ = 120^\circ$   
90° ÷ 2 = 45°  
180° - 120° = 60°  
 $\angle x \rightarrow 180^\circ - 60^\circ - 45^\circ = 75^\circ$   
a)∠x = 75°      b)∠y = 120°

6)624

7)a)(3x - 24) yrs old  
b)15 yrs old

8)a)45 / 18      b)324

13)  $1u + 174 = 3u - 98$

$1u = 3u - 272$

$3u - 1u = 2u$

$2u \rightarrow 272$

$272/2 = 136$

a)  $136 \times (4+1) = 680$

b)  $(136 \times 3) - 98 = 310$

14)  $28.9L = 28900cm^3$

$40cm \times 28cm \times 25cm = 28000cm^3$

$28900cm^3 - 28000cm^3 = 900cm^3$

$7cm \times 6cm = 42cm^2$

$8cm \times 6cm = 48cm^2$

$48cm^2 + 42cm^2 = 90cm^2$

$900 \div 90 = 10$

$25 + 10 = 35cm$

15)  $30 \times 1u = 30u$

$50 \times (1u+12) = 50u + 600$

$30u + 1240 = 50u + 600$

$30u + 640 = 50u$

$50u - 30u = 20u$

$20u \rightarrow 640$

$1u = 32$

$32 + 12 = 44$

$44 \times 50 = 2200$

16)  $3/7 + 3/8 = 45/56$

$1 - 45/56 = 11/56$

$56/11 \times 110km = 560m$

$560km/7h = 80km/h$

17) 450

18) 380