



**NAN HUA PRIMARY SCHOOL
PRELIMINARY EXAMINATION – 2011
PRIMARY 6**

MATHEMATICS

Paper 1

Total Time for Paper 1 : 50 minutes

Section A : 15 Multiple Choice Questions (20 marks)

Section B : 15 Short Answer Questions (20 marks)

INSTRUCTIONS TO CANDIDATES

1. Write your name and index number in the space provided.
2. Do not turn over the page until you are told to do so.
3. Follow all instructions carefully.
4. Answer all questions.
5. Shade your answers in the Optical Answer Sheet (OAS) provided for Questions 1-15.
6. You are not allowed to use the calculator for Paper 1.

Marks Obtained

Paper 1		/ 40
Paper 2		/ 60
Total		/ 100

Name: _____ ()

Class: P 6 _____

Date : 24 August 2011

Parent's Signature: _____

Section A (20marks)

Questions 1 to 10 carry 1 mark each. Questions 11 to 15 carry 2 marks each. For each question, four options are given. One of them is the correct answer. Make your choice (1, 2, 3 or 4). Shade the oval (1, 2, 3 or 4) on the OAS.

1. 7 thousands + 5 tens + 2 hundredths is _____.

- (1) 7 052
- (2) 705.2
- (3) 705.02
- (4) 7 050.02

2. Round off 1.899 to the nearest hundredth.

- (1) 1.80
- (2) 1.89
- (3) 1.90
- (4) 1.99

3. How many quarters are there in $4\frac{1}{2}$?

- (1) 7
- (2) 9
- (3) 12
- (4) 18

4. Simplify $6 + 3r - 4 - 2r$

- (1) $10 + r$
- (2) $10 - 5r$
- (3) $2 + r$
- (4) $2 - 5r$

5. The average of 2 numbers is 30. If one number is twice of the other, find the smaller number.

- (1) 10
- (2) 20
- (3) 30
- (4) 40.

6. Express 62% as a decimal.

- (1) 0.062
- (2) 0.62
- (3) 6.2
- (4) 62.0

7. The total surface area of a cube has the same value as its volume. Find the volume of the cube.

- (1) 27 cm³
- (2) 64 cm³
- (3) 125 cm³
- (4) 216 cm³

8. ABCD is a parallelogram. Which one of the following statements is false?

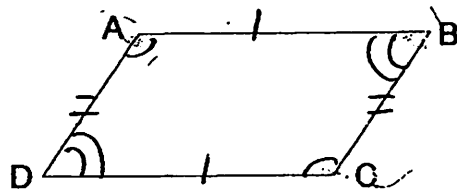

- (X) $\angle ABC = \angle ADC$
- (X) $\angle BAD = \angle BCD$
- (X) $\angle ABC + \angle BCD = 180^\circ$
- (X) $\angle ABC + \angle ADC = 180^\circ$

9. A cuboid has a volume of 96 cm^3 and a base area of 16 cm^2 . What is the height of the cuboid?
- (1) 6 cm
 - (2) 12 cm
 - (3) 24 cm
 - (4) 48 cm
10. Find the area of a semi-circle of diameter 4 m.
- (1) $2\pi \text{ m}^2$
 - (2) $4\pi \text{ m}^2$
 - (3) $8\pi \text{ m}^2$
 - (4) $16\pi \text{ m}^2$
11. What is the perimeter of a quarter of a circle of radius 7 cm? (Take $\pi = \frac{22}{7}$)
- (1) 11 cm
 - (2) 18 cm
 - (3) 25 cm
 - (4) 58 cm
12. $\frac{1}{2}$ of a rectangle overlaps with $\frac{1}{3}$ of a circle. What fraction of the figure is overlapped?
- (1) $\frac{2}{3}$
 - (2) $\frac{2}{5}$
 - (3) $\frac{1}{4}$
 - (4) $\frac{1}{5}$

13. The figure below shows the net of a cube with 6 different numbers printed on each of its faces. The sum of the numbers on opposite faces is 15. What are the values of p , q and r respectively?

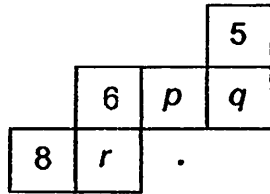

- (A) 7, 9, 10
 (B) 10, 9, 7
 (C) 9, 10, 7
 (D) 10, 7, 9

14. Which one of the following shapes does not tessellate?

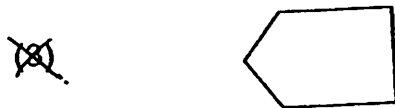
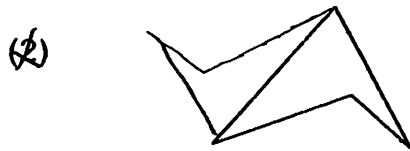

15. What is the volume of a cube if all its edges add up to 36 cm?

- (1) 9 cm³
 (2) 27 cm³
 (3) 64 cm³
 (4) 81 cm³

Section B (20 marks)

Questions 16 to 25 carry 1 mark each. Write your answers in the spaces provided.
For questions which require units, give your answers in the units stated. [10 marks]

16. Arrange the following in ascending order.

$$\frac{2}{3}, \frac{2}{5}, \frac{1}{2}, \frac{3}{4}$$

Ans : _____

17. Express $1\frac{3}{8}$ as a decimal.

Ans : _____

18. The number of members in a club increased from 250 to 750. What was the percentage increase in the number of members?

Ans : _____ %

19. Sue has $\frac{4}{9}$ as many ribbons as Lin.

Find the ratio of Lin's ribbon to Sue's ribbon.

Ans : _____

Subtotal	/ 4
----------	-----

20. Among 20 people who are being interviewed, 12 like basketball and 18 like volleyball. All of them like at least one sport. How many people like both basketball and volleyball?

Ans : _____

21. Find the perimeter of a rhombus of side 4 cm.

Ans : _____ cm

22. A rectangle is divided into 4 rectangles with areas, 15 cm^2 , 45 cm^2 , 108 cm^2 and $x \text{ cm}^2$. Find the value of x .

45 cm^2	108 cm^2
15 cm^2	$x \text{ cm}^2$

Ans : _____

23. Ron spent $\frac{1}{4}$ of his money on a tie and $\frac{1}{3}$ of the remainder on a shirt.

What fraction of his money was left?

Ans : _____

Subtotal	1.4
-----------------	------------

24. $\frac{2}{3}$ of Joe's money is equal to $\frac{2}{5}$ of Ian's money.

Find the ratio of Joe's money to Ian's money.

Ans : _____

25. What is the 9th number in the number sequence below?

1, 4, 9, 16, 25, , 121, 144

Ans : _____

Subtotal	12
-----------------	-----------

Questions 26 to 30 carry 2 marks each. Show your working clearly in the space provided for each question and write your answers in the spaces provided. For each questions which require units, give your answers in the units stated. [10 marks]

26. A square peg of area 8 cm^2 just fits in a round hole.
What is the radius of the round hole?

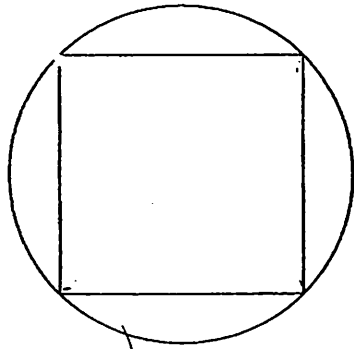

Ans : _____ cm

Do not write
in this space

27. Sam and Jed took part in a 100-metre race. When Sam had run 80 m, Jed only managed to run 60 m. How far was Jed from the finishing line when Sam just dashed through it?

Ans : _____ m

Subtotal

/ 4

28. Shade 2 squares in the figure so that there is a line of symmetry.

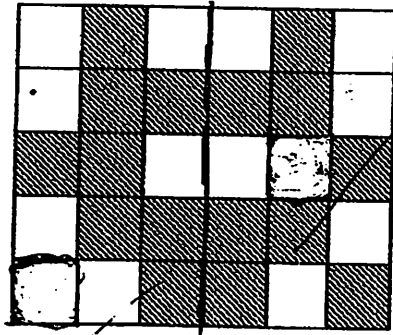

Do not write
in this space

29. The line AB is 14 cm.

Find the sum of the circumferences of the 2 circles. (Take $\pi = \frac{22}{7}$)

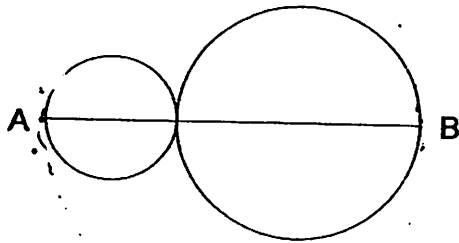

Ans : _____ cm

Subtotal

/ 4

30. The figure below is not drawn to scale. ABCD is a square. ADE is an equilateral triangle. Find $\angle DFE$.

Do not write
in this space

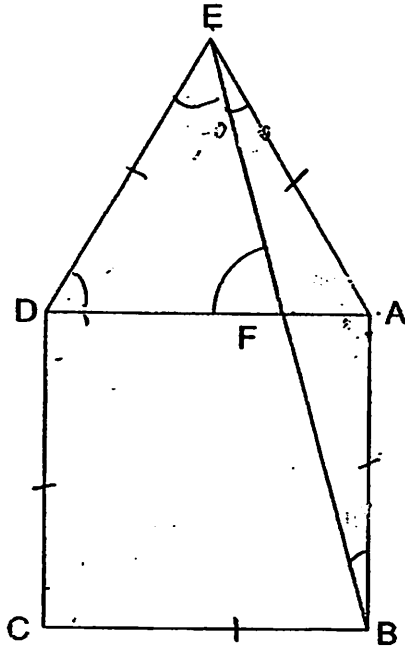

Ans : _____ °

Subtotal	T2
----------	----

END OF PAPER



NAN HUA PRIMARY SCHOOL
PRELIMINARY EXAMINATION – 2011
PRIMARY 6

MATHEMATICS

Paper 2

Total Time for Paper 2: 1 hour 40 minutes

5 Short Answer Questions (10 marks)

13 Structured / Long Answer Questions (50 marks)

INSTRUCTION TO CANDIDATES

1. Write your name and index number in the space provided.
2. Do not turn over the page until you are told to do so.
3. Follow all instructions carefully
4. Answer all questions and show your workings clearly.
5. You are allowed to use a calculator.

Marks Obtained

Total		/ 60
-------	--	------

Name : _____ ()

Class : 6 _____

Date : 24 August 2011

Parent's Signature : _____

Section A (10 marks)

Questions 1 to 5 carry 2 marks each.
Show your working clearly in the space provided for each question and write your answers in the spaces provided.
For questions which require units, give your answers in the units stated.

1. Tim is x years old. His sister is 8 years older than him. Find their total age in 3 years' time.

Ans : _____ years [2m]

Do not write
in this space

2.

Number of pets	0	1	2	3	4
Number of pupils	4	12	?	10	6

The above table shows the number of pets owned by a class of pupils. If the total number of pets owned by the pupils is 82, how many pupils owned 2 pets?

Ans : _____ [2m]

3. How many circles of radius 2 cm can be cut from a piece of cardboard measuring 69 cm by 9 cm?

Ans : _____ [2m]

4. There are two metal bars of length 72 cm and 96 cm. Short bars of equal length are cut from the two metal bars without any remainders. What is the largest possible length of each short bar?

Ans : _____ cm [2m]

5. Write down the decimal that is exactly halfway between 0.36 and 0.94.

Ans : _____ [2m]

Do not write
in this space

Section B (50 marks)

For questions 6 to 18, show your working clearly in the space provided for each question and write your answers in the spaces provided.

The number of marks available is shown in the brackets [] at the end of each question or part question. Remember to include the units wherever possible.

6. Construct a triangle ABC such that $AB = 6 \text{ cm}$, $\angle BAC = 60^\circ$ and $\angle BCA = 30^\circ$. Measure and write the length of AC . [3m]

Do not write
in this space

Ans : $AC =$ _____

7. Cathy spent $\frac{1}{5}$ of her money on pens and $\frac{5}{8}$ of her remaining money on 2 books. Each book costs 15 times as much as a pen. How many pens did she buy?

Ans : _____ [3m]

3

8. The pie chart represents the number of red, yellow and blue marbles. There are 3 more red than yellow marbles. How many yellow marbles are there?

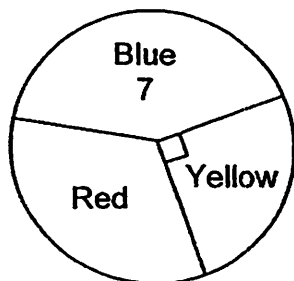

Ans : _____ [3m]

9. A shopkeeper bought a handbag for \$360. What is the selling price of the handbag so that he can allow a discount of 10% of the selling price and yet earn 10% on the cost price?

Ans : _____ [3m]

Do not write
in this space

10. The table below shows the time John took to run 100 metres during his training sessions.

Attempt	1st	2nd	3rd	4th	5th	6th	7th	8th
Time Taken (in seconds)	18	18	21	19	15	20	22	?

If he wishes to improve his average time taken by 0.5 seconds, what timing should he attain for his 8th attempt?

Ans: _____ [3m]

11. A and B are squares. The lengths of the squares are whole numbers.

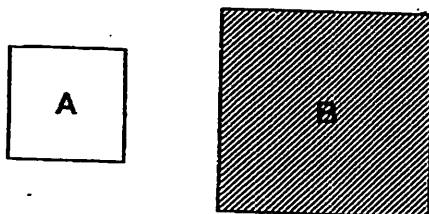

When Square A is placed over Square B as shown in the figure below, the shaded area is 85 cm².

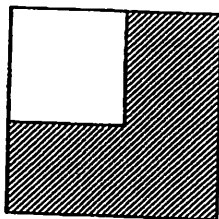

Find the perimeter of the shaded region.

Ans : _____ [3m]

5

Do not write
in this space

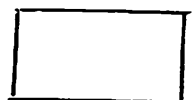

12. In the figure, $\angle BAD$ is a right angle and $AC = AD$.
 Find (a) $\angle ACD$.
 (b) $\angle BDC$.

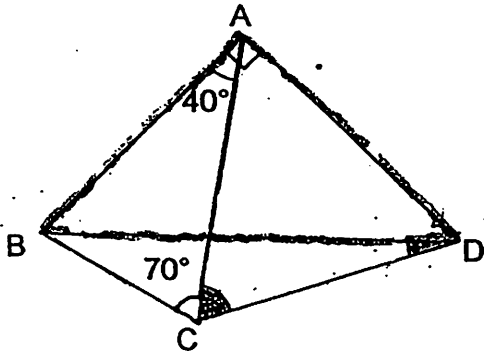

Do not write
in this space

Ans : (a) _____ [1m]
 (b) _____ [3m]

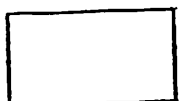

13. 80% of the people in a hall were adults. 75% of the children in the hall were boys. There were 36 more boys than girls.
Some boys left the hall, after which 10% of the remaining people in the hall were boys. How many boys left the hall?

Do not write
in this space

Ans : _____ [4m]

7



14. A train has a capacity of 154 seats. Tickets for seats are sold at \$8 and \$12. There are $\frac{1}{5}$ more \$8-seats than \$12-seats on the train.

During a trip, the amount collected from the sales of \$8 tickets was twice the amount collected from the \$12 tickets. The total amount collected was \$540. How many \$8-seats were not taken during the trip?

Do not write
in this space

Ans : _____ [4m]

8



15. A car left Town A at 08 00 and travelled to Town B at an average speed of 60 km/h. At the same time, a lorry left Town B for Town A. At 11 30, the car and the lorry were 85 km apart after passing each other earlier. If the car arrived at Town B at 13 00, at what time would the lorry arrive at Town A?

Do not write
in this space

Ans : _____ [5m]



16. A rectangular tank is filled with water to a height of 40 cm. 2 taps, A and B, are turned on at the same time. Water flows from Tap A at a rate of 500 cm^3 per minute. Water drains out from Tap B at a rate of 800 cm^3 per minute.

- (a) How much water will be left in the tank after 20 minutes?
(Give your answer in litres)
- (b) All the water that drained out from the tank is to be collected in 2 containers such that the height of water in the 2 containers is the same. The base areas of the 2 containers are 500 cm^2 and 300 cm^2 . What will be the height of the water level in the 2 containers after 20 minutes?

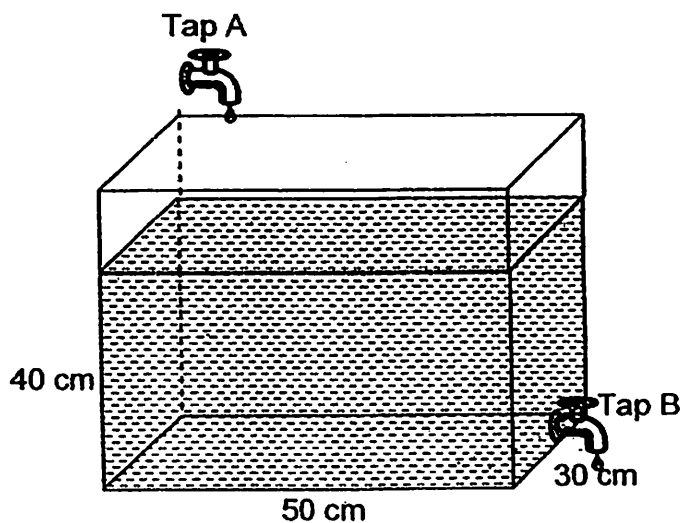

Do not write
in this space

Ans : (a) _____ [2m]

(b) _____ [3m]

10



17. The series of figures below are made up of unit squares and unit triangles.

In the figures below, a unit square is represented by \square

and a unit triangle is represented by \triangle .

Study the patterns carefully and answer the questions that follow.



Figure 1

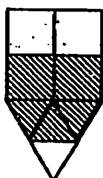

Figure 2

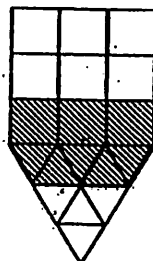

Figure 3

(a) Complete the following table. [1m]

Figure Number	Number of Unit Squares (Shaded and Unshaded)	Total Number of Shaded Unit Squares and Shaded Unit Triangles	Total Number of Unit Squares and Unit Triangles (Shaded and Unshaded)
1	1	2	2
2	4	5	8
3	9	8	18
4			

(b) Find the number of unit squares in Figure 20.

(c) Find the figure that has a total of 101 shaded unit squares and shaded unit triangles.

(d) Find the total number of unit squares and unit triangles in Figure 25.

Ans : (b) _____ [1m]

(c) _____ [1m]

(d) _____ [2m]

Do not write in this space



18. Ben and Mary went shopping with a total of \$204. Ben had \$12 more than Mary. Mary spent 4 times as much money as Ben and was left with half the amount of money that Ben had left.

- (a) How much money did Ben bring along for shopping?
- (b) How much money had Ben left after shopping?

Do not write
in this space

Ans : (a) _____ [2m]

(b) _____ [3m]



END OF PAPER

ANSWER SHEET

EXAM PAPER 2011

SCHOOL : NAN HUA
SUBJECT : PRIMARY 6 MATHEMATICS

TERM : PRELIMINARY

Q1	Q2	Q3	Q4	Q5	Q6	Q7	Q8	Q9	Q10	Q11	Q12	Q13	Q14	Q15
4	3	4	3	2	2	4	4	1	1	3	3	1	1	2

- 16) $2/5, 1/2, 2/3, 3/4$ 17) 1.375 18) 200% 19) 9:4 20) 10 people
 21) 16cm 22) 36 23) $1/2$ 24) 3:5 25) 81 26) 2cm
 27) 25m 28) 29) 44cm 30) 75°

Paper 2

1) Tim(now) $\rightarrow X$

Sister(now) $\rightarrow X+8$

Tim(3 yrs later) $\rightarrow X+3$

Sister(3 yrs later) $\rightarrow X+3+8$

$= X+11$

Total (3yrs later) $\rightarrow X+11+X+3$

$= (2X + 14)$ years

$$2) 12 + 30 + 24 = 66$$

$$82 - 66 = 16$$

$$16 \div 2 = 8 \text{ pupils}$$

$$3) 69\text{cm} \div 4\text{cm} \approx 17$$

$$9\text{cm} \div 4\text{cm} \approx 2$$

$$17 \times 2 = 34 \text{ circles}$$

$$4) 72\text{cm} \div 24\text{cm} = 3$$

$$96\text{cm} \div 24\text{cm} = 24\text{cm}$$

$$5) 0.94 - 0.36 = 0.58$$

$$0.58 \div 2 = 0.29$$

$$0.29 + 0.36 = 0.65$$

$$6) AC = 12\text{cm}$$

7) Pens $\rightarrow 1/5$

$$2\text{books} \rightarrow 5/8 \times 4/5 = 1/2$$

$$1\text{book} \rightarrow 1/4$$

$$1\text{pen} \rightarrow 1/15 \times 1/4 = 1/60$$

$$1/5 \div 1/60 = 1/5 \times 60/1 = 12\text{pens}$$

$$8) 7 + 3 = 10$$

$$10 \div 2 = 5 \text{ yellow marbles}$$

9) Cost of handbag \rightarrow \$360
 Price with profit of 10%
 $\rightarrow 110\% \times \$360 = \$396$
 90% \rightarrow \$396
 $100\% \rightarrow \$396 \div 90 \times 100$
 $= \$440$

10) $18+18+21+19+15+20+22=133$
 $133 \div 7 = 19$
 $(19 - 0.5) \times 8 = 148$
 $148 - 133 = 15 \text{ seconds}$

11) $(11 \times 11) - (6 \times 6) = 85$
 A is 6cm
 B is 11cm
 Perimeter of shaded region
 $=$ perimeter of square B
 $11\text{cm} \times 4 = 44\text{cm}$

12) a) $\angle CAD \rightarrow 90^\circ - 40^\circ = 50^\circ$
 $\angle ACD \rightarrow (180^\circ - 50^\circ) \div 2 = 65^\circ$
 b) $(180^\circ - 90^\circ) \div 2 = 45^\circ$
 $65^\circ - 45^\circ = 20^\circ$

13) At first
 Adults : children
 $80u : 20u$
 Boys: girls
 $15u : 5u$

14) \$8 seats : \$12 seats
 $6 \times 4 : 5 \times 4$
 $84 : 70$
 $\$8 \times 84 + 70 \times \$12 = \$1512$ will be collected
 \$8 tickets : \$12 tickets
 $2 : 1$
 $\$360 : \180
 $\$672 - \$360 = \$312$
 $\$312 \div \$8 = 39$ \$8- seats

$10u \rightarrow 36$
 $1u \rightarrow 3.6$
In the end
 Adults & Girls : Boys
 $9P : 1P$
 $9p \rightarrow 85 \times 3.6 = 306$
 $1P \rightarrow 306 \div 9 = 34$
 $15u \rightarrow 3.6 \times 15 = 54$
 $54 - 34 = 20$ boys

15) Distance between A & B $\rightarrow 60\text{km} \times 5 = 300\text{km}$
 Distance by car (8 - 11.30a.m.) $\rightarrow (60 \times 3\frac{1}{2})\text{km} = 210\text{km}$
 Distance by lorry $\rightarrow (300 - 120 + 85)\text{km} = 175\text{km}$
 Speed by lorry $\rightarrow (175\text{km} \div 3\frac{1}{2})\text{km} \text{ 1h} = 30\text{km/h}$
 $300 \div 50 = 6$
 6h after 0800 = 1400

16) a) $800\text{cm}^3 - 500\text{cm}^3 = 300\text{cm}^3$
 $300\text{cm}^3 \times 20 = 6000\text{cm}^3$
 $40\text{cm} \times 50\text{cm} \times 30\text{cm} = 60000\text{cm}^3$
 $60000\text{cm}^3 - 6000\text{cm}^3 = 54000\text{cm}^3 = 54\text{L}$
 b) water let out by Tap B in 20min $\rightarrow 20 \times 800 = 16000$
 $16000 \div (500+300) = 20\text{cm}$

17) a) 16, 11, 32
 b) $20 \times 20 = 400$ unit squares
 c) $101 - 2 = 99$
 $99 \div 3 = 33$
 $33 + 1 = 34$
 d) $25 \times 25 \times 2 = 1250$

18) a) \$108
 b) \$96